



Read this document carefully before using this device. The guarantee will be expired by damaging of the device if you don't attend to the directions in the user manual. Also we don't accept any compensations for personal injury, material damage or capital disadvantages.

ENDA ET2011 PID TEMPERATURE CONTROLLER

Thank you for choosing ENDA ET2011 temperature controller.

- * 77 x 35mm sized.
- * Selectable dual-set value.
- * Selectable thermocouple types or Pt100 input.(Selection must be specified in order).
- * Automatic calculation of PID parameters.(SELF TUNE).
 Enter PID parameters of the system if they are known at the beginning. Otherwise, Self-Tune should be activated.
- * Soft-Start feature.
- * Input offset feature.
- * C/A2 Relay output can be programmable as alarm or control output.
- * Selectable SSR control output.
- * Selectable heating/cooling control.
- * In the case of sensor failure periodical running or relay state can be selected.
- * CE marked according to European Norms.



TECHNICAL SPECIFICATIONS

Input type	Temperature range		Accuracy
	°C	°F	
Pt 100 Resistance thermometer EN 60751	-99.9...300.0 °C	-99.9...543.0 °F	± 0,5% (of full scale) ± 1 digit
Pt 100 Resistance thermometer EN 60751	-200...600 °C	-328...1112 °F	± 0,5% (of full scale) ± 1 digit
J (Fe-CuNi) Thermocouple EN 60584	0... 600°C	+32... +1112°F	± 0,5% (of full scale) ± 1 digit
K (NiCr-Ni) Thermocouple EN 60584	0...1300°C	+32... +2372°F	± 0,5% (of full scale) ± 1 digit
T (Cu-CuNi) Thermocouple EN 60584	0... 400°C	+32... +752°F	± 0,5% (of full scale) ± 1 digit
S (Pt10Rh-Pt) Thermocouple EN 60584	0...1700°C	+32... +3092°F	± 0,5% (of full scale) ± 1 digit
R (Pt13Rh-Pt) Thermocouple EN 60584	0...1700°C	+32... +3092°F	± 0,5% (of full scale) ± 1 digit

ENVIRONMENTAL CONDITIONS	
Ambient/storage temperature	0 ... +50°C/-25... +70°C (with no icing)
Max. Relative humidity	80% up to 31°C decreasing linearly 50% at 40.
Rated pollution degree	According to EN 60529 Front panel : IP65 Rear panel : IP20
Height	Max. 2000m

Do not use the device in locations subject to corrosive and flammable gases.

ELECTRICAL CHARACTERISTICS	
Supply	230V AC +%10 -%20, 50/60Hz or 24V AC %±10, 50/60Hz
Power consumption	Max. 5VA
Wiring	Power connector: 2.5mm ² screw-terminal, Signal connector: 1,5mm ² screw-terminal conenction.
Line resistance	Max. 100ohm
Data retention	EEPROM (minimum 10 years)
EMC	EN 61326-1: 2006
Safety requirements	EN 61010-1: 2010 (Pollution degree 2, overvoltage category II)

OUTPUTS	
C/A2 output	Relay : 250V AC, 8A (for resistive load), Selectable as NO+NC Control or Alarm2 output. Relay : 250V AC, 16A (for resistive load), Selectable as NO Control or Alarm2 output.
SSR output	Max 20mA 12Volt (as control output)
Life expectancy for relay	Withot load 30.000.000 mechanical operation; 250V AC, on the 8A resistive load 100.000 electrical switching

CONTROL	
Control type	Single set-point and alarm control
Control algorithm	On-Off / P, PI, PD, PID (selectable)
A/D converter	12 bit
Sampling time	100ms
Proportional band	Adjustable between 0% and 100%. If Pb=0%, On-Off control is selected.
Control period	Adjustable between 1 and 250 seconds
Hysteresis	Adjustable between 1 and 50°C/F
Output power	The ratio of power at a set point can be adjusted between 0% and 100%

HOUSING	
Housing type	Suitable for flush-panel mounting according to DIN 43 700.
Dimensions	W77xH35xD71mm
Weight	Approx. 200g (after packing)
Enclosure material	Self extinguishing plastics.

While cleaning the device, solvents (thinner, benzine, acid etc.) or corrosive materials must not be used.

up to date: 01022014, modification reserved and can be change any time previous notice !

TERMS

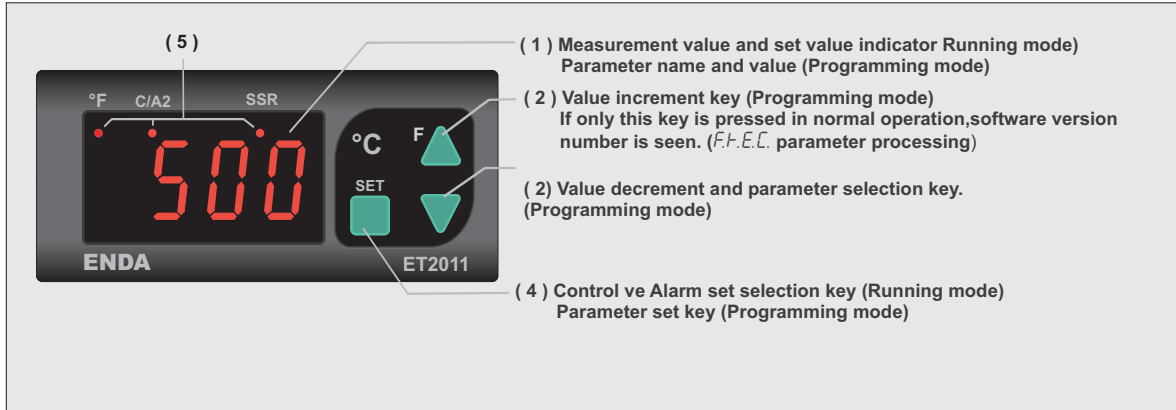

(1) PV and SV display	7 segment, 4 digits red LED display
Character heights	12 mm
(2),(3),(4) Keypad	Mikro switch
(5) State indicator	For control, Alarm1 and SSR outputs 3 digits red LED

ALARM2 OUTPUT TYPES

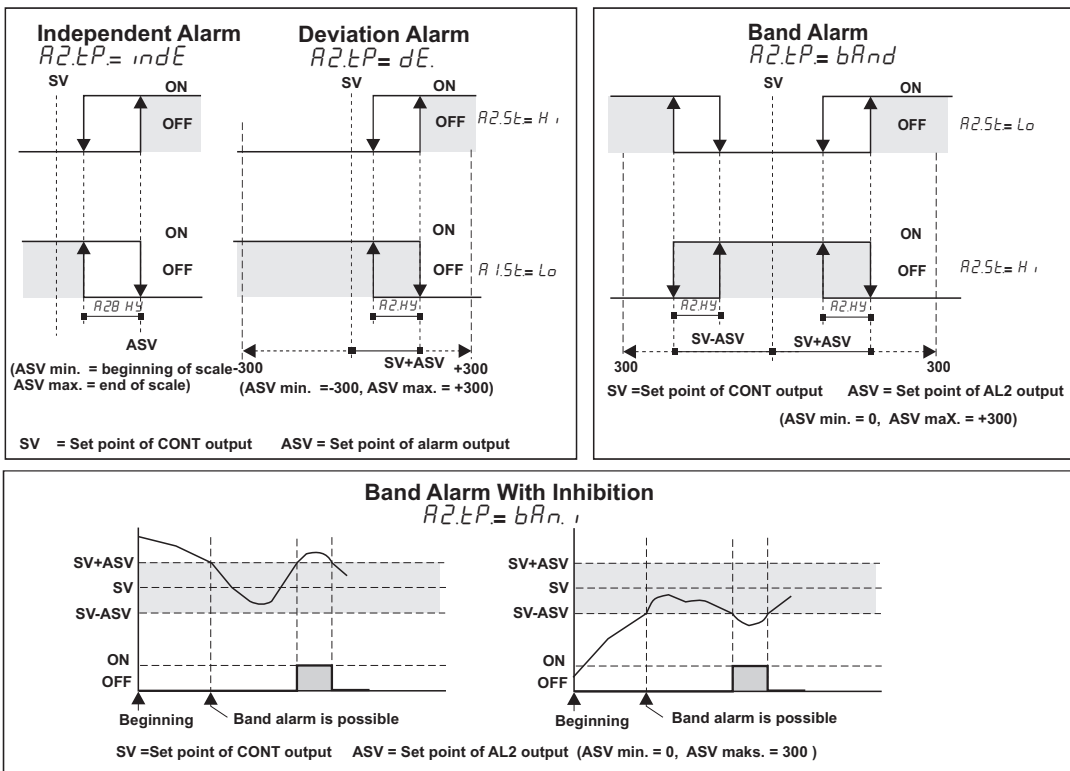

MODIFICATION OF CONTROL AND ALARM SET POINTS

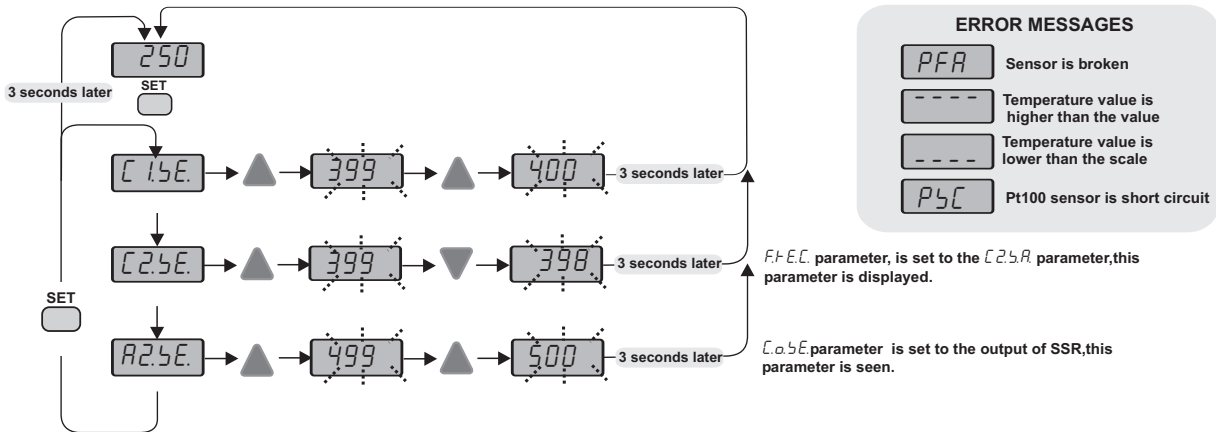

DIMENSIONS

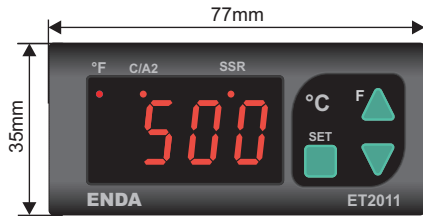

For removing the device from the panel:
 - While pressing both side of the device in direction 1, push it in direction 2.

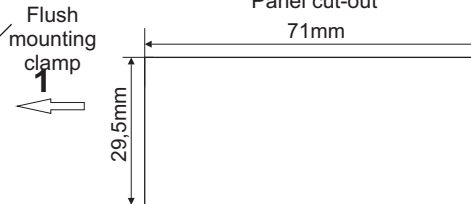
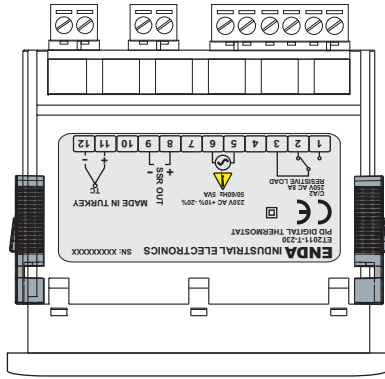
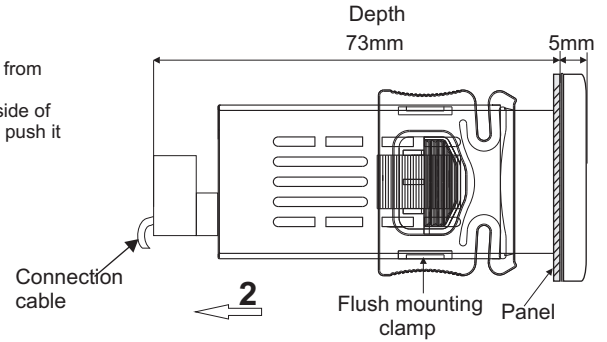

Note

- 1) Panel thickness should be maximum 7mm.
- 2) If there is no 60mm free space at back side of the device, it would be difficult to remove it from the panel.

Order Code: ET2011-X-XXX-X

Input selection
 RT.....PT100 input
 T.....TC input

Supply voltage
 230VAC.....230V AC
 110VAC.....110V AC
 024VAC.....24V AC
 SM.....9-30VDC/7-24V AC

Contact current selection
 None.....8A contact output
 P.....16A contact output

CONNECTION DIAGRAM



ENDA ET2011 is intended for installation in control panels. Make sure that the device is used only for intended purpose. The shielding must be grounded on the instrument side. During an installation, all of the cables that are connected to the device must be free of energy. The device must be protected against inadmissible humidity, vibrations, severe soiling. Make sure that the operation temperature is not exceeded. All input and output lines that are not connected to the supply network must be laid out as shielded and twisted cables. These cables should not be close to the power cables or components. The installation and electrical connections must be carried on by a qualified staff and must be according to the relevant locally applicable regulations.

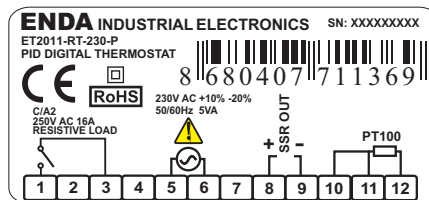
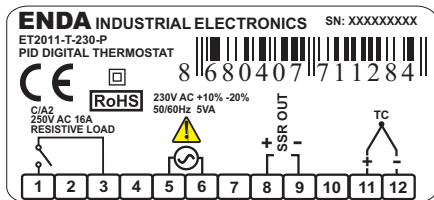
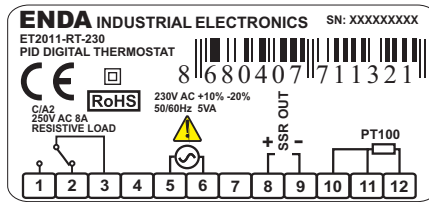
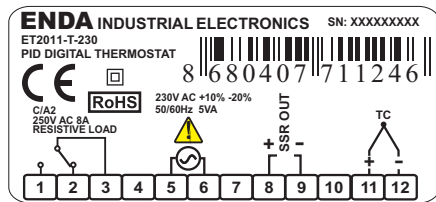

Holding screw
0.4-0.5Nm

Equipment is protected throughout
by DOUBLE INSULATION.

NOTE :

SUPPLY:

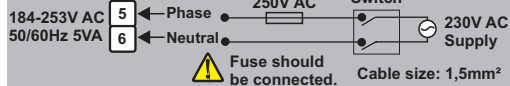

- Note
- 1) Mains supply cords shall meet the requirements of IEC 60227 or IEC 60245.
 - 2) In accordance with the safety regulations, the power supply switch shall bring the identification of the relevant instrument and it should be easily accessible by the operator.