

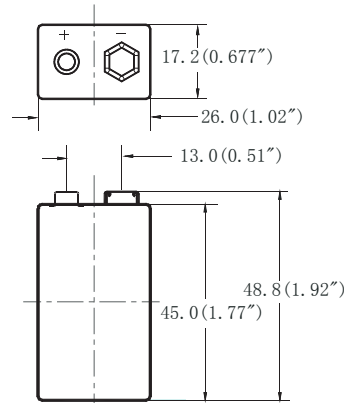

# PRL9001

## Technical Specification



**CR9V/P**  
Lithium Manganese  
Dioxide(Li-MnO<sub>2</sub>) Batteries

### ELECTRICAL CHARACTERISTICS

(typical values for cells stored for one year or less, at 23 °C)

● Nominal capacity	1200mAh
At 900 Ω (9.0 mA), +23 °C, 5.4V cut off. The capacity restored by the Cell varies according to current drain, temperature and cut off voltage.	
● Nominal voltage	9.0V
● Maximum recommended continuous current	700mA
(To get 50% of the nominal capacity at +25 °C with 5.4V cut off. Higher currents possible. Consult EVE.)	
● Maximum pulse current capability	1500mA
Pulse capability varies according to pulse characteristics(frequency and Duration), temperature, cell history (storage conditions prior to usage) and the application's acceptable minimum voltage.	
● Storage (recommended)	30 °C max
(For more severe condition consult EVE.)	
● Operating temperature range	-30 °C / +85 °C
(Operation at temperature different form ambient may lead to reduced capacity and lower voltage plateau readings.)	

**Remark :**  
CR9V battery with Printed CircuitBoard (PCB) for safety design, the PCB include three diodes and one polyswithch .The three diodes can well protect from abnormal charging currents or forced discharge during use ,and the polyswitch can limit the discharging current in abnormal use ,such as short circuit or larger charging current .

#### CAUTION:

Risk of fire and burns. Do not recharge, disassemble, heat above 100 °C or incinerate. Do not mix fresh batteries with used Lithium Batteries or other battery types..

#### TRANSPORTATION:

For a complete description of transportation regulations and definitions of the transportation regulations and definitions of the transportation classifications

### KEY FEATURES

- ✓ High energy density
- ✓ Wide operating temperature range
- ✓ High pulse current capability
- ✓ Lasts up to 5X longer than ordinary 9V alkaline batteries
- ✓ Lasts up to 10X longer than Carbon-zinc batteries
- ✓ Low self discharge rate (less than 0.16% per month at +23 °C)
- ✓ Over 10 years service life
- ✓ Glass-to-Metal sealed
- ° Underwriters Laboratories (UL) Component Recognition (File Number MH10330) Material Safety Datasheet-MSDS M002

### MAIN APPLICATIONS

- ✓ Medical Devices
- ✓ Music/Audio Devices
- ✓ Smoking alarm
- ✓ Instrumentation
- ✓ Safety Devices
- ✓ Communication Devices
- ✓ Parking Meter
- ... Etc

Note: Any representations in this data sheet concerning performance are for informational purpose only and are not construed as warranties, either expressed or implied, of future performance.

# CR9V/P

## 1. BATTERY LIFE COMPARISON

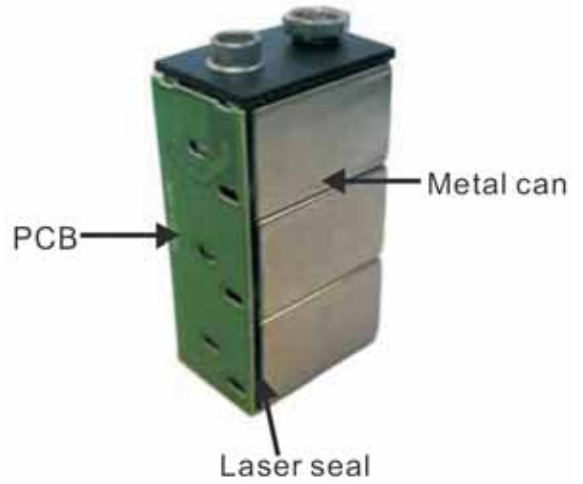
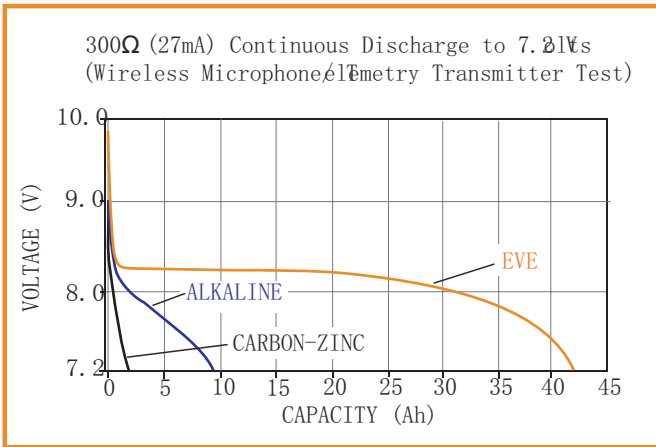

## 2. DISCHARGE CHARACTERISTICS @ +23°C

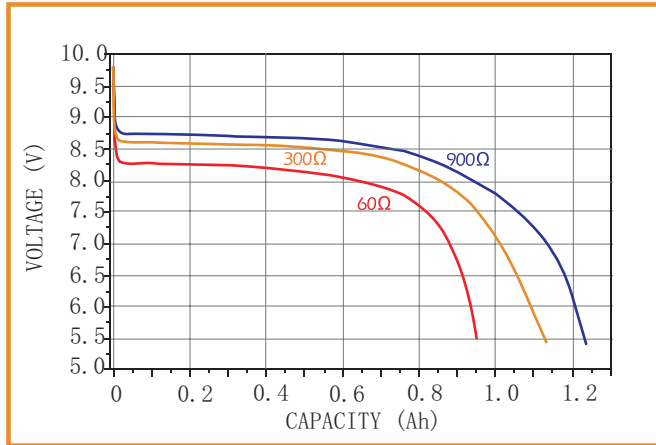

## PHYSICAL CHARACTERISTICS

Length(max.)	26.0mm (1.02")
Width(max.)	17.2mm (0.677")
Height(max.)	48.8mm (1.92")
Typical weight	50.0g (1.77oz)

## 3. TYPICAL DISCHARGE VS. TEMPERATURE

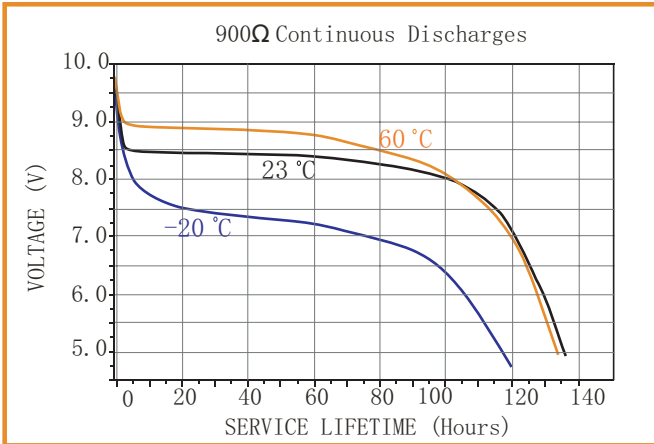

## 4. SHORT CIRCUIT TEMPERATURE VS. CURRENT VS. TIME

