

**cell type:** Li-Ion  
**cell size:** 16340  
**built-in cell:** round cell 850mAh

**Conditions**

**nominal voltage:** 3.6 V

**capacity**

nominal: 850 mAh discharge at 0.2C  
 minimum: 830 mAh discharge at 0.2C  
 780 mAh discharge at 1C  
 ta: 20°C; EV(Discharge End Voltage): 2.75V

**discharge**

max. continuous discharge current: 1700 mA ta: 0...45°C  
**important:** avoid cell temperature above 60°C  
 discharge end voltage: ≥ 2.75 V (recommended)

**external charge (at +/- poles)**

charging method: CC - CV (Constant Current - Constant Voltage)  
 charge current: 170 mA at standard charge  
 max. charge current: 850 mA at fast charge  
 charge end voltage: 4.2 V ± 50mV  
 charge cut off by time: 8 h at standard charge  
 1.5...2.0 h at fast charge  
 by current drop: 17 mA end current - cut off

**internal resistance:** ≤ 150 mΩ at 1kHz, sine wave measurement according to IEC 896-2

energy: 3.06 Wh

**protection functions**

overcharge cut off voltage: 4.27 V ± 0.05V  
 deep disch.cut off voltage: 2.4 V ± 0.1V  
 overload cut off current: 3.0 A ± 1A

**life time expectance**

(C>70% of min. capacity) ≥ 300 cycles at 0.5C charge/discharge rate

**self discharge:** ≤ 2 %/month at 20°C  
 ≤ 5 %/month at 30°C  
 ≤ 10 %/month at 40°C

**ambient temperature range:**

0...45 °C charge  
 - 20...60 °C discharge  
 - 20...25 °C storage max. 1year  
 - 20...45 °C storage max. 3months

recommended SOC: 30...50 % for long-time stoarge  
 (SOC = state of charge)

**mechanical specifications**

cell dimensions (incl. sleeve)  
 diameter d1: 17.0 - 1 mm  
 diameter d2: max. 9.6 mm  
 height h1: 35.5 - 1 mm  
 height h2: min. 1 mm  
 weight: 19 ± 1.5 g

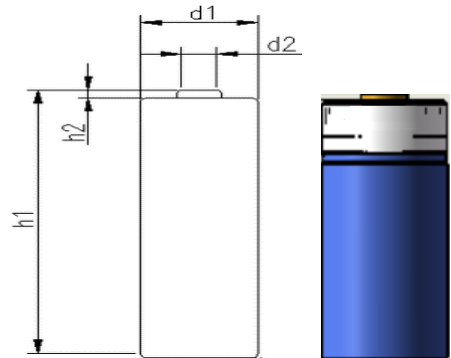

111

	<b>ANSMANN Specifications for model:</b>	<b>Protected 16340 Li-Ion Battery</b>
		<b>3.7V 850mAh</b>
	data sheet no. / part no.	
	s.n.	704507
	author / date	TG / 15.09.2020