



Please read this document carefully before using this product. The guarantee will be invalidated if the device is damaged by not following instructions detailed in the manual. The company shall not be responsible for any damage or losses however caused, which may be experienced as a result of the installation or use of this product.

ENDA ET1411 DIGITAL THERMOSTAT

Thank you for choosing ENDA ET1411 temperature controller.

- * 35 x 77mm sized.
- * On-Off control.
- * Single contact output for selectable heating or cooling control.
- * Single NTC probe input.
- * Offset value can be entered for NTC probe.
- * In the case of probe failure, output state can be selected on, off or periodical running.
- * Upper and lower limits of the setpoint can be adjusted.
- * Temperature unit can be selected °C or °F.
- * CE marked according to European Norms.



Order Code : ET1411-NTCH-□□□□□□
1

- 1- Supply Voltage**
 230VAC.....230V AC
 24.....24V AC/DC
 12.....12V AC/DC

Connection Diagram



ENDA ET1411 is intended for installation in control panels. Make sure that the device is used only for intended purpose. The electrical connections must be carried out by a qualified staff and must be according to the relevant locally applicable regulations. During an installation, all of the cables that are connected to the device must be free of electrical power. The device must be protected against inadmissible humidity, vibrations, severe soiling and make sure that the operation temperature is not exceeded. The cables should not be close to the power cables or components.

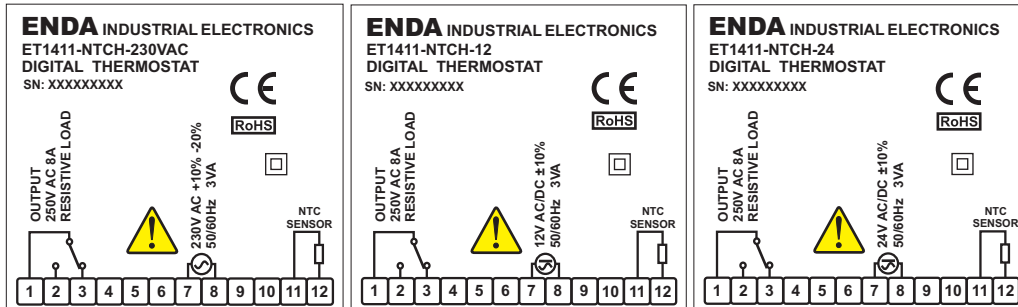

Equipment is protected throughout by DOUBLE INSULATION

Holding screw 0.4-0.5Nm.

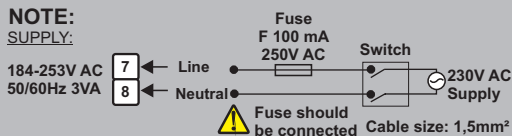

- Note:**
 1) Mains supply cords shall meet the requirements of IEC 60227 or IEC 60245.
 2) In accordance with the safety regulations, the power supply switch shall bring the identification of the relevant instrument and it should be easily accessible by the operator.

Technical Specifications

ENVIRONMENTAL CONDITIONS	
Ambient/storage temperature	0 ... +50°C/-25 ... 70°C (with no icing)
Max. relative humidity	80%, up to 31°C decreasing linearly 50% at 40°C
Rated pollution degree	According to EN 60529 Front panel : IP65 Rear panel : IP20
Height	Max. 2000m

! Do not use the device in locations subject to corrosive and flammable gasses.

ELECTRICAL CHARACTERISTICS	
Supply voltage	230V AC +10% -20%, 50/60Hz or 12/24V AC/DC ±10%, 50/60Hz.
Power consumption	Max. 3VA
Wiring	2.5mm² screw-terminal connections.
Scale	-60.0 ... +150.0°C (-76.0 ... +302.0°F)
Sensitivity/Accuracy	0.1°C / ±1°C
Time Accuracy	(±1%-1sec)
Indicator	4 digits, 12.5mm, 7 segment yellow LED
EMC	EN 61326-1: 1997, A1: 1998, A2: 2001 (Performance criterion B is satisfied for EMC tests. The device is designed to operate in controlled electromagnetic environment)
Safety requirements	EN 61010-1: 2001 (Pollution degree 2, overvoltage category II)

OUTPUT	
OUTPUT	Relay: 250V AC, 8A (for resistive load), NO+NC; 1/2 HP 240V AC Cosφ = 0.4 (for inductive load)
Life expectancy for relay	Mechanical 30.000.000; Electrical 100.000 operation.

CONTROL	
Control type	Single-setpoint control
Control algorithm	On-Off control
Hysteresis	Adjustable between 0.1 ... 20.0°C.

HOUSING	
Housing type	Suitable for flush-panel mounting.
Dimensions	W77xH35xD71mm
Weight	Approx. 205g (After packing)
Enclosure material	Self extinguishing plastics

! While cleaning the device, solvents (thinner, benzene, acid etc.) or corrosive materials must not be used.

Dimensions

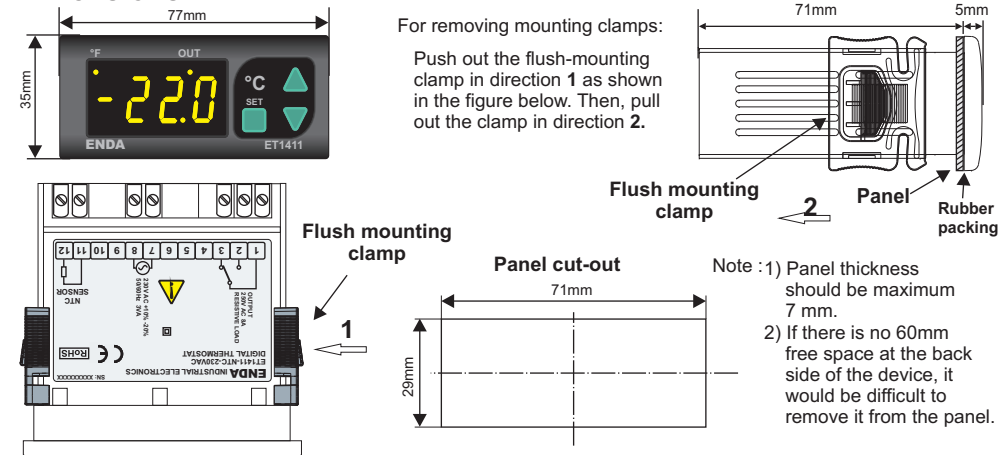

up to date: 01022014, modification reserved and can be change any time previous notice !

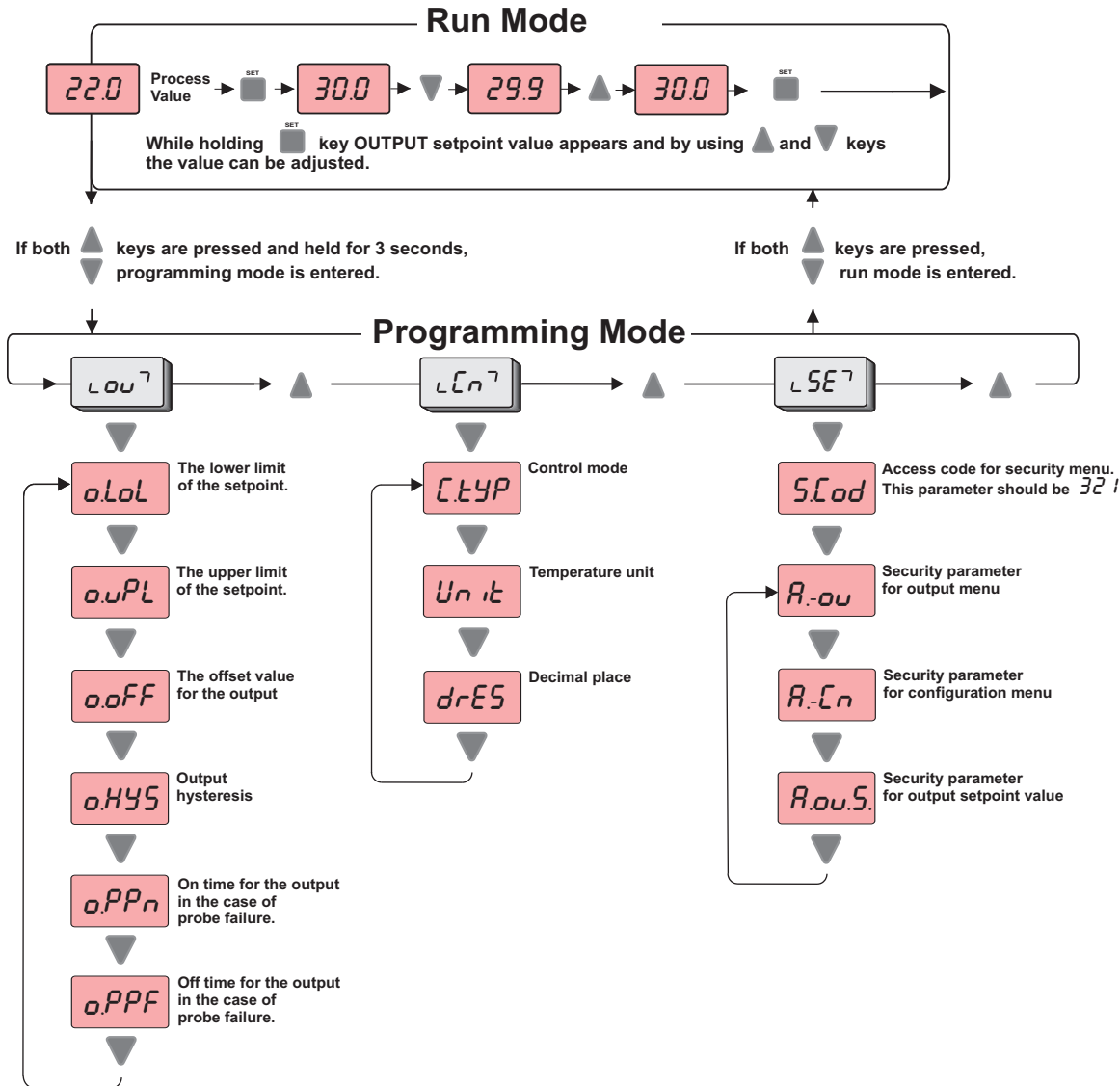
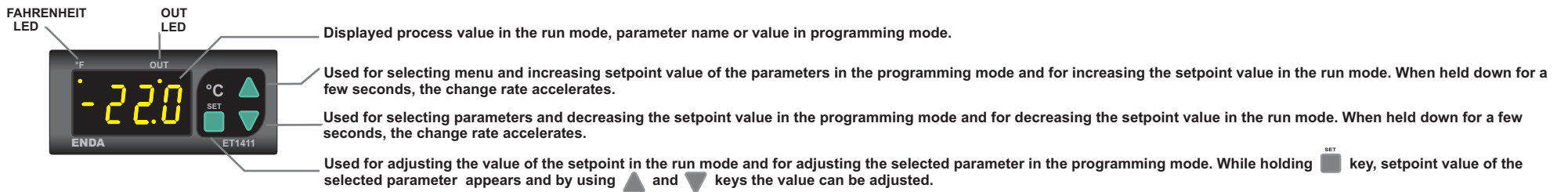

PARAMETER TABLE					
Lou Menu of Output control parameters		MIN	MAX	UNIT	DEF. SET
oLoL	The lower limit of the setpoint.	-60.0	ouPL	°C	-60
ouPL	The upper limit of the setpoint.	oLoL	150.0	°C	150
oOFF	The offset value for the output	-20.0	20.0	°C	0
oHYS	Output hysteresis	0.1	20.0	°C	2
oPPn	On time for the output in the case of probe failure.	0	255	Min.	0
oPPF	Off time for the output in the case of probe failure.	0	255	Min.	1
Lcn Menu of Configuration					
Ctrl	Control mode (HEAT = Heating control, COOL = Cooling control)	HEAT	COOL		HEAT
Unit	Temperature unit	°C	°F		°C
drES	Decimal place (no = no decimal point, 22 °C, YES = with decimal point, 22.3 °C)	no	YES		no
LSE Menu of Parameter security					
Rou	Security parameter for menu of output control	nonE = Menu is invisible. PYES = Parameters of menu are changeable.			
Rcn	Security parameter for menu of configuration	Pno = Parameters of menu are only visible.			
RouS	Security parameter for output setpoint value	PYES = Setpoint value is changeable. Pno = Setpoint value is only visible.			

