



### Characteristics features

- ▶ Wide temperature range -60 ... +150 °C
- ▶ High accuracy of characteristics  $\pm 0.5\%$
- ▶ Replaceable without calibration
- ▶ Miniaturised dimensions
- ▶ Fast response behaviour
- ▶ Low priced, ideal for mass applications

### Typical areas of application

- ▶ Air-conditioning, building automation
- ▶ Ventilators and ventilation systems
- ▶ Electrical domestic appliances
- ▶ Medical systems
- ▶ Industrial instrumentation
- ▶ Laboratory device, portable instruments
- ▶ Battery cells
- ▶ Automotive applications



### Features

The NTC Temperature sensors of series TS-NTC have a wide measuring range of -60 ... +150 °C, and hence, are suitable for applications where till now expensive platinum resistors were being used.

Both the basic resistance as well as the B-value are within a tolerance of  $\pm 0.5\%$ , so that the component can be used in many applications without temperature calibration and can also be replaced without re-adjustment.

Hence, by means of simple resistance measurement, an accuracy of  $\pm 0.12$  K at 25 °C can be achieved in this way. In the temperature range of -60 ... +85 °C, the maximum error is around  $\pm 0.5$  K.

Further product advantages are its very small dimensions, low thermal mass and high upward gradient, which enables simple evaluation circuits. Due to its high impedance, only a small measuring current is required which minimises power consumption in battery operated applications.

Due to these outstanding performance data, the precision NTC is also suitable for meticulous application, for example, in the medical field. The component is also very well suitable for long term stable, industrial thermometer or laboratory devices which can be calibrated as well. Since the component is very low priced, it can also be used in price sensitive mass applications like automotive or consumer products.

### Technical data

| Precision Temperature sensor CON-TS-NTC   |                   |
|---|-------------------|
| Measuring principle   | NTC               |
| Measuring range   | -60 ... +150 °C   |
| Nominal resistance at 25 °C   | See table         |
| Resistance tolerance at 25 °C   | $\pm 0.5\%$       |
| B-value Tolerance $R_{25/85}$   | $\pm 0.5\%$       |
| Response time $T_{66}$ in air   | 15s               |
| Self heating  | 1.2 mW / K        |
| Max. power loss   | 6 mW              |
| Connection wires  | Tinned steel      |
| Dimensions  | 3.8 x 2.8 x 17 mm |
| Rights reserved for change in technical data due to technological advancements! |                   |

For further information, please visit our website: [www.hygroSens.com](http://www.hygroSens.com)





## Type overview

| Type        | R <sub>25</sub> | B-value      |
|-------------|-----------------|--------------|
| TS-NTC-202  | 2.00 kΩ ±0.5%   | 3976 K ±0.5% |
| TS-NTC-232  | 2.252 kΩ ±0.5%  | 3976 K ±0.5% |
| TS-NTC-502  | 5.00 kΩ ±0.5%   | 3976 K ±0.5% |
| TS-NTC-103  | 10.0 kΩ ±0.5%   | 3435 K ±0.5% |
| TS-NTC-103A | 10.0 kΩ ±0.5%   | 3976 K ±0.5% |
| TS-NTC-203  | 20.0 kΩ ±0.5%   | 3976 K ±0.5% |
| TS-NTC-503  | 50.0 kΩ ±0.5%   | 4220 K ±0.5% |
| TS-NTC-104  | 100 kΩ ±0.5%    | 4261 K ±0.5% |
| TS-NTC-204  | 200 kΩ ±0.5%    | 4470 K ±0.5% |

## Drawing

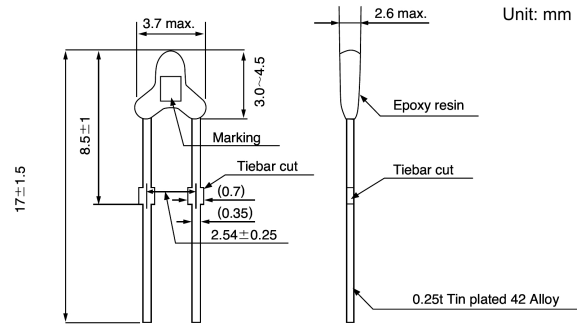

## Application notes

In comparison to other temperature sensors, the component offers a substantially higher sensitivity, because of which the circuit design expenses are minimised. In the high impedance types, the power consumption of measuring circuit is reduced, and hence, these types are particularly suitable for battery operated applications. With the help of a parallel resistor, the exponential characteristic of the component can be pre-linearised, in order to more effectively use the linear conversion range of an AD converter. Because of the low thermal mass, the response time (T66) is very fast i.e. 0.7 sec.

## Resistance tables

Extensive data on the sensor is available as EXCEL tables. The resistance table is on ITS90 basis. Further information on measuring circuits or linearisation methods can be obtained on request!

For further information, please visit our website: [www.hygroSens.com](http://www.hygroSens.com)