

# INSTRUCTION MANUAL

## Photoelectric Sensor

### Adjustable Range Reflective EQ-30 Series



- Never use this product as a sensing device for personnel protection.
- In case of using sensing devices for personnel protection, use products which meet standards, such as OSHA, ANSI or IEC etc., for personnel protection applicable in each region or country.

## 1 SPECIFICATIONS

Type	Adjustable range reflective		
	NPN output type	PNP output type	Two outputs type
Item	EQ-34	EQ-34-PN	EQ-34W
Adjustable range (Note 2)	0.2 to 2m		Far (Main): 0.2 to 2m Near (Sub): Refer to diagram in (Note 3)
Sensing range (with white non-glossy paper at setting distance 2m)	0.1 to 2m		Far (Main): 0.1 to 2m Near (Sub): 0.2 to 2m [with Near (Sub) distance for adjuster at max.]
Hysteresis	10% or less of operation distance		
Supply voltage	10 to 30V DC Ripple P-P 10% or less		
Current consumption	50mA or less	55mA or less	90mA or less
Output	NPN open-collector transistor • Maximum sink current: 100mA • Applied voltage: 30V DC or less (between output and 0V) • Residual voltage: 1V or less (at 100mA sink current) 0.4V or less (at 16mA sink current)	PNP open-collector transistor • Maximum source current: 100mA • Applied voltage: 30V DC or less (between output and +V) • Residual voltage: 1V or less (at 100mA source current) 0.4V or less (at 16mA source current)	<Far (Main) output, Near (Sub) output> NPN open-collector transistor • Maximum sink current: 100mA • Applied voltage: 30V DC or less (between output and 0V) • Residual voltage: 1V or less (at 100mA sink current) 0.4V or less (at 16mA sink current)
Output operation	Switchable either Detection-ON or Detection-OFF		
Short-circuit protection	Incorporated		
Response time	2ms or less		
Operation indicator	Red LED (lights up when the output is ON)		Far (Main) output: Red LED [lights up when the Far (Main) output is ON] Near (Sub) output: Red LED [lights up when the Near (Sub) output is ON]
Stability indicator	Green LED (lights up under stable light received condition or stable dark condition) (Note 4)		
Distance adjuster	2-turn mechanical adjuster with pointer		Far (Main): 2-turn mechanical adjuster with pointer Near (Sub): Variable adjuster
Automatic interference prevention function	Incorporated (Two units of sensors can be mounted close together.)		
Protection	IP67 (IEC)		
Ambient temperature	-20 to +55°C (No dew condensation or icing allowed), Storage: -25 to +70°C		
Ambient humidity	35 to 85% RH, Storage: 35 to 85% RH		
Emitting element	Infrared LED (modulated)		
Receiving element	2-segment photodiode		
Material	Enclosure: Polyallylate and Polyethylene terephthalate, Lens: Polyallylate		
Cable	0.3mm <sup>2</sup> 3-core cabtyre cable, 2m long	0.3mm <sup>2</sup> 4-core cabtyre cable, 2m long	
Weight	150g approx.		
Accessory	Adjusting screwdriver: 1pc.		

Notes: 1) The model No. with suffix '-J' stands for the connector type. (EQ-34W is excluded.)  
(e.g.) As for the connector type of EQ-34 'EQ-34-J'  
Use the mating cables as shown below.

CN-24-C2 (Straight type, 4-core, 2m)  
CN-24-C5 (Straight type, 4-core, 5m)



CN-24L-C2 (Elbow type, 4-core, 2m)  
CN-24L-C5 (Elbow type, 4-core, 5m)



The model No. with suffix '-C5' stands for the 5m cable length type. (EQ-34-PN is excluded.)  
(e.g.) As for the 5m cable length type of EQ-34 'EQ-34-C5'

- 2) The adjustable range stands for the maximum sensing range which can be set with the adjuster. The sensor can detect an object 0.1m, or more, away. However, the detectable area of the Near (Sub) type of the EQ-34W begins at 0.2m.

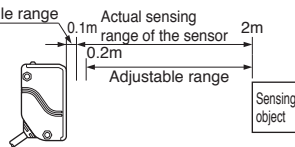

- 3) The Near (Sub) distance adjustable range, L2, changes with the setting of the Far (Main) distance, L1, as shown in the table below.

#### EQ-34W Near (Sub) distance adjustable range

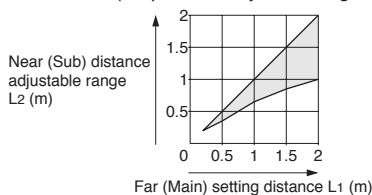

EQ-34W	
Far (Main) setting distance L1	Near (Sub) distance adjustable range L2
2m	1 to 2m
1.5m	0.85 to 1.5m
1m	0.65 to 1m
0.5m	0.35 to 0.5m
0.2m	0.2m

- 4) Refer to '6 STABILITY INDICATOR' for the details of the stability indicator.

## 2 CAUTIONS

- Make sure that the power supply is off while wiring.
- Take care that wrong wiring will damage the sensor.
- Verify that the supply voltage variation is within the rating.
- If power is supplied from a commercial switching regulator, ensure that the frame ground (F.G.) terminal of the power supply is connected to an actual ground.
- In case noise generating equipment (switching regulator, inverter motor, etc.) is used in the vicinity of this product, connect the frame ground (F.G.) terminal of the equipment to an actual ground.
- Do not run the wires together with high-voltage lines or power lines or put them in the same race-way. This can cause malfunction due to induction.
- Extension up to total 100m, is possible with 0.3mm<sup>2</sup>, or more, cable. However, in order to reduce noise, make the wiring as short as possible.
- Do not use during the initial transient time (50ms) after the power supply is switched on.
- Take care that the sensor is not directly exposed to fluorescent lamp from a rapid-starter lamp, a high frequency lighting device or sunlight etc., as it may affect the sensing performance.
- Avoid dust, dirt, and steam. Do not use it in places having excessive vapor, dust, etc., or where it may come in direct contact with corrosive gas.
- Take care that the sensor does not come in direct contact with water, oil, grease, organic solvents, such as, thinner etc., or strong acid, and alkaline.
- Make sure that stress by forcible bend or pulling is not applied directly to the sensor cable joint.
- Since the cable end is not waterproof, do not use the sensor in the application where water may seep in from the cable end.
- When connecting the mating cable to the connector type sensor, the tightening torque should be 0.4N·m or less.

## 3 MOUNTING

- The tightening torque should be 0.8N·m or less.

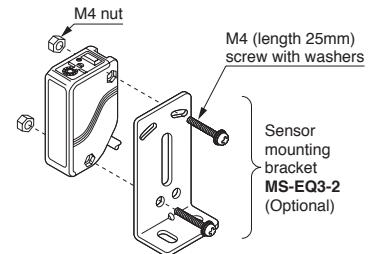

- Care must be taken regarding the sensor mounting direction with respect to the object's direction of movement.

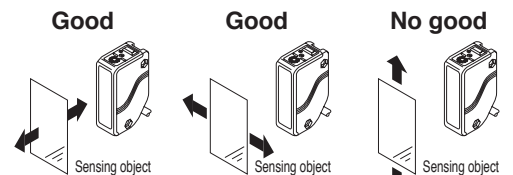

Do not make the sensor detect an object in this direction because it may cause unstable operation.

- When detecting a specular object (aluminum or copper foil, etc.) or an object having a glossy surface or coating, please take care that there are cases when the object may not be detected due to a small change in angle, wrinkles on the object surface, etc.
- When a specular body is present below the sensor, use the sensor by tilting it slightly upwards to avoid wrong operation.



- If a specular body is present in the background, wrong operation may be caused due to a small change in the angle of the background body. In that case, install the sensor at an inclination and confirm the operation with the actual sensing object.
- Some object may produce the dead zone right in front of the sensor.

## 4 I/O CIRCUIT DIAGRAMS

### ● NPN output type / EQ-34

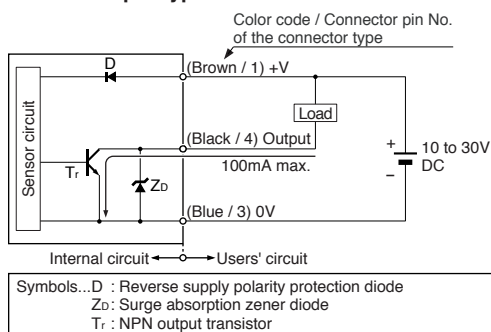

### ● PNP output type / EQ-34-PN

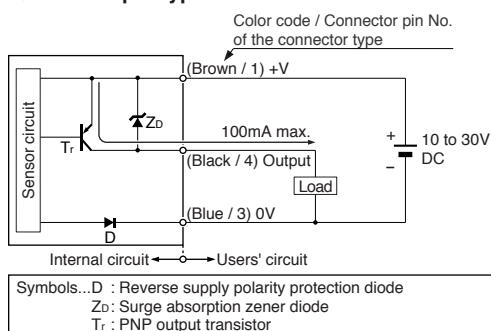

### ● Two outputs type / EQ-34W

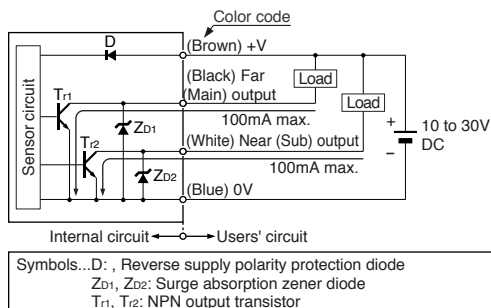

### ● Connector pin position of the connector type

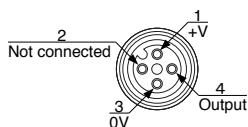

## 5 AUTOMATIC INTERFERENCE PREVENTION FUNCTION

- EQ-30 series is incorporated with automatic interference prevention function. Up to two sets of sensors can be installed close together.

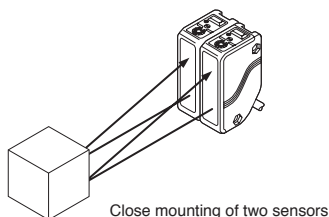

## 6 STABILITY INDICATOR

- Since the EQ-30 series uses a 2-segment photodiode as its receiving element, and sensing is done based on the difference in the incident beam angle of the reflected beam from the sensing object, the output and the operation indicator operate according to the object distance. Further, the stability indicator shows the margin of the incident light intensity and not that of the object distance. Hence, the distance at which it lights up/off depends on the object reflectivity and is not at all related to the output operation. Do not use the sensor when the stability indicator is off (unstable light received condition), since the sensing will be unstable.

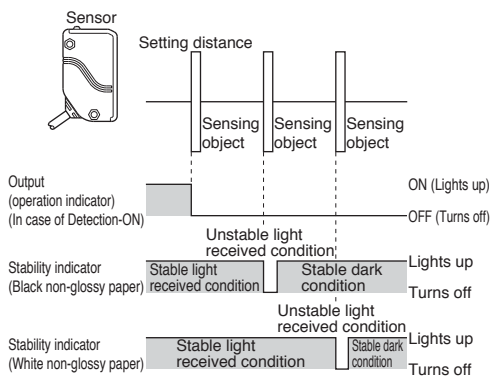

## 7 DISTANCE ADJUSTMENT

### EQ-34, EQ-34-PN

#### ● Top-view

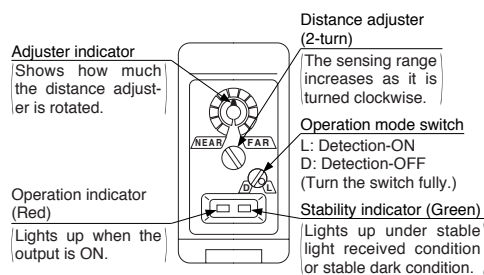

#### ● Adjusting procedure

Step	Description	Distance adjuster
①	Turn the distance adjuster fully counterclockwise to the minimum sensing range position of 0.2m approx.	Turn fully
②	Place an object at the required distance from the sensor, turn the distance adjuster gradually clockwise, and find out point (A) where the sensor changes to the light received condition.	
③	Remove the object, turn the distance adjuster further counterclockwise, and find out point (B) where the sensor changes to the light received condition again with only the background. When the sensor does not go to the light received condition even if the adjuster is fully turned clockwise, point (B) is this extreme point in the range.	
④	The optimum position to stably detect objects is the center point between (A) and (B).	Optimum position

Note: Use the accessory adjuster screwdriver to turn the distance adjuster slowly. Turning with excessive force will cause damage the adjuster.

### EQ-34W

#### ● Top-view

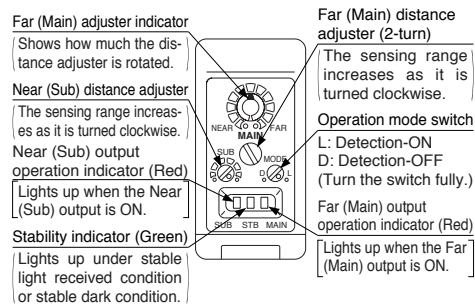

#### ● Adjusting procedure - Far (Main) side

Step	Description	Distance adjuster
①	Turn the Far (Main) distance adjuster fully counterclockwise to the minimum sensing range position of 0.2m approx.	Turn fully
②	Place an object at the far place at the required distance from the sensor, turn the Far (Main) distance adjuster gradually clockwise, and find out point (A) where the sensor changes to the light received condition.	
③	Remove the object, turn the Far (Main) distance adjuster further clockwise, and find out point (B) where the sensor changes to the light received condition again with only the background. When the sensor does not go to the light received condition even if the adjuster is fully turned clockwise, point (B) is this extreme point in the range.	
④	The optimum position to stably detect objects for the Far (Main) setting is the center point between (A) and (B).	Optimum position

#### ● Near (Sub) side

Step	Description	Distance adjuster
①	Turn the Near (Sub) distance adjuster fully counterclockwise to the minimum sensing range point.	Turn fully
②	Place an object at the near position, at the required distance from the sensor, turn the Near (Sub) distance adjuster gradually clockwise, and find out point (A) where the sensor changes to the light received condition.	
③	Remove the object from the near position, and place the object for Far (Main) sensing at the sensing position. Turn the Near (Sub) distance adjuster further clockwise, and find out point (B) where the sensor changes to the light received condition again with only the background. When the sensor does not go to the light received condition even if the adjuster is fully turned clockwise, point (B) is this extreme point in the range.	
④	The optimum position to stably detect objects for the Near (Sub) setting is the center point between (A) and (B).	Optimum position

Notes: 1) Use the accessory adjuster screwdriver to turn the distance adjuster slowly. Turning with excessive force will cause damage the adjuster.  
2) The Far (Main) distance adjustment should be done before the Near (Sub) distance adjustment. Take care that the Near (Sub) setting distance changes with change in the Far (Main) setting distance.

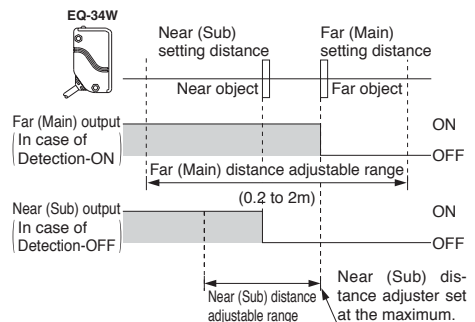

## SUNX Limited

<http://www.sunx.co.jp/>

### Head Office

2431-1 Ushiyama-cho, Kasugai-shi, Aichi, 486-0901, Japan

Phone: +81-(0)568-33-7211 FAX: +81-(0)568-33-2631

### Overseas Sales Dept.

Phone: +81-(0)568-33-7861 FAX: +81-(0)568-33-8591

PRINTED IN JAPAN