



SPS-035 / SPS-050 / SPS-060 (12V,15V,24V) SDS-030

User's Menu

Please read this user's guide carefully before setup.

Input:

1. Input range:

SPS-035 / SPS-050 / SPS-060: Universal full range AC 85V ~ 264V or DC 120V ~ 375V

SDS-030A: 9.5 ~ 18VDC / SDS-030B: 18 ~ 36VDC / SDS-030C: 36 ~ 72VDC

2. **Inrush current:** When turn on input power source, there is peak current (inrush current) running through filter capacitor of power supply. During power supply operating, it is important not to turn off input power source and then immediately turn on it again, otherwise, it may shorten power supply's life.

Inrush current could be several to tens times of the normal current. It is important to make sure input wiring, fuse and SW are able to carry inrush current.

3. For input specification, please refer to the label on the product or visit www.sunpower.com.tw for newly update data.

Output:

1. The output voltage adjustable range is $\pm 10\%$ of rated output voltage. As output power is $V_o \times A_o$, when adjusting V_o to a higher value, should decrease A_o as well, ex.:

For SPS-035-05, the rated output voltage is 5V, max output current is 7A: If adjusting output voltage to 5.5V, should decrease max output current to 6.3A as well; and even if adjusting output voltage to 4.5V, max output should not be over 7A.

2. For output specification, please refer to the label on the product or visit www.sunpower.com.tw for newly update data.

Protection:

1. **Short circuit protection:** When circuit shorted, power supply will shutdown. After short circuit has been removed, power supply will recover automatically.
2. **Over load protection:** When over loaded, power supply will shutdown. After load reduced to meet rated range, power supply will recover automatically.
3. **Over voltage protection:** When output voltage exceeds rated range, power will shut down. After voltage reduced to meet rated range, it will recover automatically.
4. **Input polarity reverse protection:** SDS-030 series only.

To Parallel Switching Power Supplies

Adjusting output voltage of each power supply to a same level, and then serialize a diode after the positive pole of each power supply. The diode must be able to carry current that higher than power supply's max output, and should be equipped with a proper heat sink. (It is suggested to choose a power supply which max output could meet your system's requirement instead of paralleling lower output power supplies)

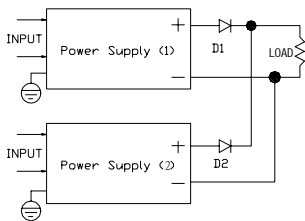

To Serialize Switching Power Supplies:

a. To up rise output voltage:

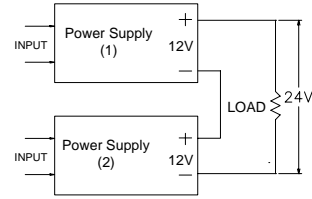

b. To generate both positive and negative output voltage.

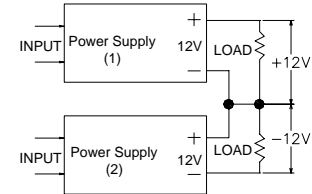

Wiring:

1. Output wiring must be thick and short enough to carry loading. The shorter and thicker the wire, the less voltage it drops (less wire loss).

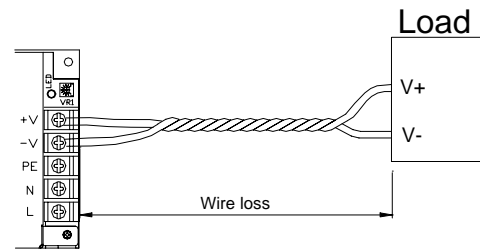

2. Connecting the PE of power supply to system's chassis with a short & thick wire can reduce noise and prevent electric shock.
3. Reference data for wires:

AWG NO.	Area (mm ²)	Constitution (Wire/mm)	Vol. Drop/1A mV/m	Max. Load Current (A)	
				U1007 (300V 80°C)	U1015 (600V 105°C)
30	0.051	7/0.102	358	0.12	---
28	0.081	7/0.127	222	0.15	0.2
26	0.129	7/0.16	140	0.35	0.5
24	0.205	11/0.16	88.9	0.7	1.0
22	0.326	17/0.16	57.5	1.4	2.0
20	0.517	26/0.16	37.6	2.8	4.0
18	0.823	43/0.16	22.8	4.2	6.0
16	1.309	54/0.18	14.9	5.6	8.0
14	2.081	41/0.26	9.5	---	12.0
12	3.309	65/0.26	6.0	---	22.0
10	5.262	104/0.26	3.8	---	35.0

Mounting:

1. Each power supply is enclosed with mounting screws. It is suggested to use enclosed screws to setup power supply, otherwise, make sure its length must not be too long (refer to the following drawing) to cause short circuit.
2. The input wiring should be separated from output wiring to avoid noise interfere.
3. When multiple power supplies work together, be sure to keep proper distance between power supply & power supply as well as power supply and the environment for good air convection. Use extra cooling fans if needed.

A. Mounting holes dimension:

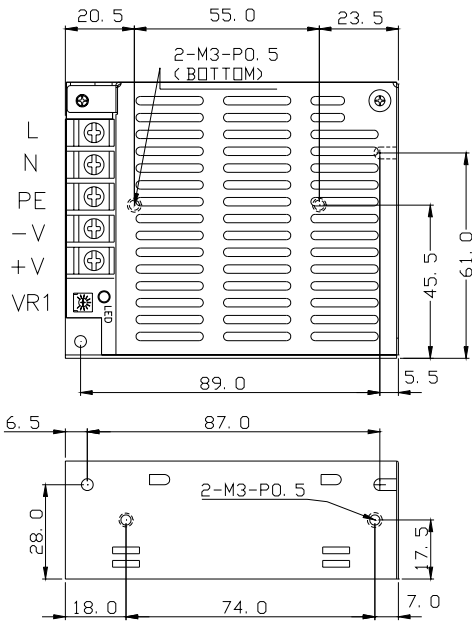

B. Din rail mounting: (contact your dealer to buy Din Rail brackets if needed)

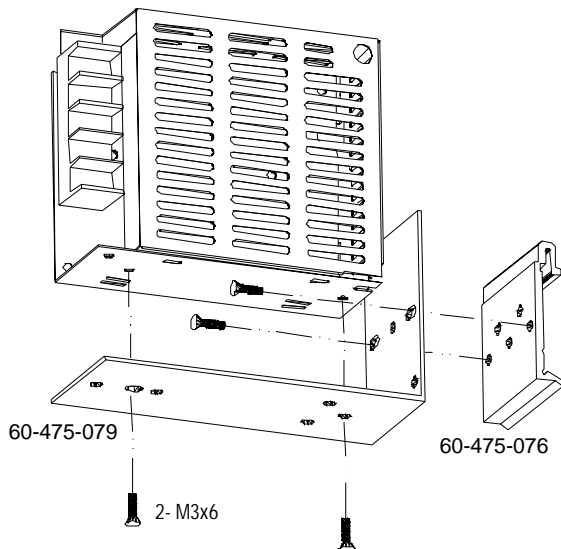
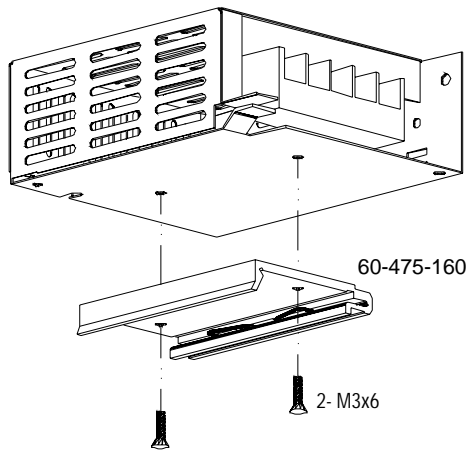

Connection:

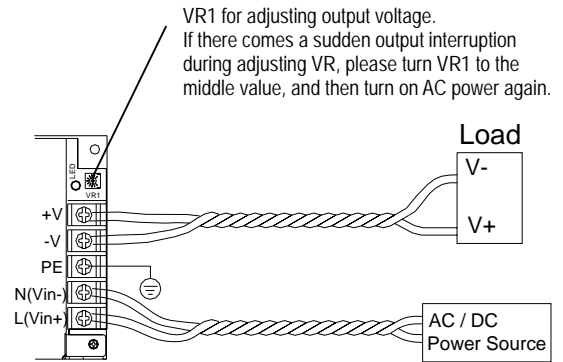

Safety terms:

1. The Y capacitor inside power supply could deliver leakage current. When multiple power supplies work in parallel or in series, the leakage current will increase to cause the possibility of getting electric shock. Make sure ground wire is thick enough to prevent the danger.
2. For AC input switching power supplies, the voltage running through primary circuit could up to 2-4 times of AC input voltage. **It is forbidden for non-technicians to open the case.** Contact your local dealer for technical support if needed.
3. The temperature inside power supply may exceed 85°C during full loading, so it is dangerous to touch power supply at this time. Be sure to keep a proper distance between power supply and combustible material.

Trouble Shooting:

If power supply couldn't work properly, please turn off input power SW, and check the following steps:

1. Check all the connections (pin in/out correct? polarity correct? etc.)
2. Does terminal well connected? If not, reconnect it, and then turn on input power source again.
3. Check load current. If over loaded, decrease loading, and then turn on input power source again. (Rated load current show on label)
4. If there comes a sudden output interruption during adjusting VR, please turn VR to the middle value, and then turn on AC power again.
5. If there is a temporary working followed by power supply shut down, it may cause by a higher inrush current requirement of the system. Replace a higher output power supply to meet the system's requirement.
6. If environmental temperature gets too low or too high?
 - (1) If the environmental temperature lower than 10°C, take either of the following steps:
 - a. Use heater to warm up the environment; or, b. Reduce loading.
 - (2) If environmental temperature higher than a certain degree, use extra cooling fans to enforce air convection, or reduce loading. (Refer to related specification)
7. If the fuse inside power supply melted, there must be something function abnormally. Find out the abnormal cause and remove it; and then replace a new fuse. Make sure the new fuse's spec must be same as the original.

If all of the above items were checked and power supply still cannot function normally, please contact your local dealer for support or e-mail info@dehner.net

SUNPOWER TECHNOLOGY CORP. operates a policy of continuous development. Therefore, we reserve the right to make changes and improvements to any of the products described in this guide without prior notice.
© SUNPOWER TECHNOLOGY CORP. All right reserved.

URL: <http://www.dehner.net>

May 8, 2003 9:22 AM 84-200-013