



# Winstar Display Co., LTD

## 華凌光電股份有限公司



住址: 407 台中市清路 163 號  
No.163 Chung Ching RD.,  
Taichune, Taiwan, R.O.C

WEB: <http://www.winstar.com.tw>  
E-mail: [winstar@winstar.com.tw](mailto:winstar@winstar.com.tw)  
Tel:886-4-24262208 Fax : 886-4-24262207

### SPECIFICATION

**CUSTOMER :** \_\_\_\_\_

**MODULE NO.:** WF57BTIBCDATO#

<p align="center"><b>APPROVED BY:</b></p> <p align="center">( FOR CUSTOMER USE ONLY )</p>	<p><b>PCB VERSION:</b> _____</p> <p><b>DATA:</b> _____</p>
---	--

SALES BY	APPROVED BY	CHECKED BY	PREPARED BY
			丘惠城
<b>ISSUED DATE: 2013-3-27</b>			



**RECORDS OF REVISION**

**DOC. FIRST ISSUE**

VERSION	DATE	REVISED PAGE NO.	<b>SUMMARY</b>
0	2013.3.27		First issue

# Contents

1. Module Classification Information
2. Summary
3. General Specification
4. Absolute Maximum Ratings
5. Electrical Characteristics
6. DC Characteristics
7. Interface Timing
8. Optical Characteristics
9. Interface
10. Block Diagram
11. Contour Drawing
12. Touch panel Information
13. Reliability
14. Package specification
15. Initial Code For Reference

# 1. Module Classification Information

W   F   57   B   T   I   B   C   D   A   T   0   #  
 ①   ②   ③   ④   ⑤   ⑥   ⑦   ⑧   ⑨   ⑩   ⑪   ⑫   ⑬

①	Brand : WINSTAR DISPLAY CORPORATION						
②	Display Type : H→Character Type, G→Graphic Type F→TFT Type						
③	Display Size : 5.7 ” TFT						
④	Model serials no.						
⑤	Backlight Type :	F→CCFL, White			T→LED, White		
⑥	LCD Polarize Type/ Temperature range/ Gray Scale Inversion Direction	I→Transmissive, W. T, 6:00 L→Transmissive, W.T,12:00					
⑦	A : TFT LCD B : TFT+FR+CONTROL BOARD C : TFT+FR+A/D BOARD D : TFT+FR+A/D BOARD+CONTROL BOARD E : TFT+FR+POWER BOARD F : TFT+CONTROL BOARD			G : TFT+FR H : TFT+D/V BOARD I : TFT+FR+D/V BOARD J : TFT+POWER BD			
⑧	Solution:						
	A: 128160	B:320234	C:320240	D:480234	E:480272	F: 640480	G: 800480
	H:1024600	I:320480	J:240320	K:800600	L:240400	M :1024768	
⑨	D: Digital    L : LVDS						
⑩	Interface :    N : without control board    A : 8Bit    B : 16Bit						
⑪	TS :    N : Without TS    T : resistive touch panel    C : capacitive touch panel						
⑫	Version						
⑬	Special Code	#:Fit in with ROHS directive regulations					

## **2.SUMMARY**

This technical specification applies to 5.7” color TFT-LCD panel. The 5.7” color TFT-LCD panel is designed for camcorder, digital camera application and other electronic products which require high quality flat panel displays. This module follows RoHS.

## **3.General Specification**

Item	Dimension	Unit	Remark
Dot Matrix	320 x RGBx240(TFT)	dots	
Module dimension	160(W) x 109(H) x13.0max(D)	mm	
Active area	115.2 x 86.40	mm	
Dot pitch	0.12 x 0.36	mm	
LCD type	TFT, Negative, Transmissive		
View Direction	12 o'clock		
Gray Scale Inversion Direction	6 o'clock		
Backlight Type	LED, Normally White		
Controller IC	SSD1963		
Interface	Digital 8080 family MPU		

\*Color tone slight changed by temperature and driving voltage.

## **4.Absolute Maximum Ratings**

Item	Symbol	Min	Typ	Max	Unit
Operating Temperature	T <sub>OP</sub>	-20	—	+70	°C
Storage Temperature	T <sub>ST</sub>	-30	—	+80	°C

Note: Device is subject to be damaged permanently if stresses beyond those absolute maximum ratings listed above

1. Temp.  $\leq 60^{\circ}\text{C}$ , 90% RH MAX. Temp.  $> 60^{\circ}\text{C}$ , Absolute humidity shall be less than 90% RH at  $60^{\circ}\text{C}$

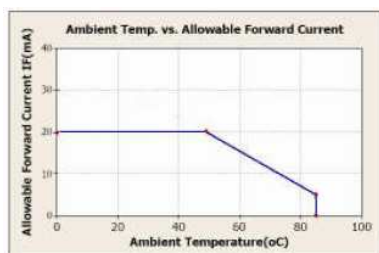

## 5. Electrical Characteristics

### 5.1. Operating conditions:

Item	Symbol	Condition	Min	Typ	Max	Unit
Supply Voltage For Logic	$V_{DD}$	—	3.0	3.3	3.6	V

### 5.2 LED driving conditions

Parameter	Symbol	Min.	Typ.	Max.	Unit	Remark
LED current		-	140	-	mA	
Power Consumption			1365	1470	mW	
LED voltage	VBL+	9.0	-	10.5	V	Note 1
LED Life Time		-	50,000	-	Hr	Note 2,3,4

Note 1 : There are 1 Groups LED

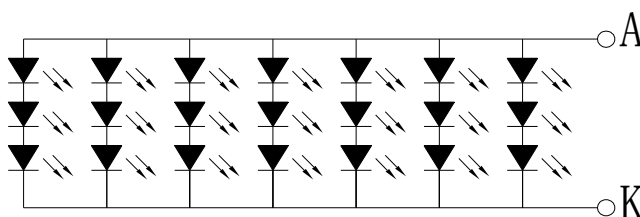

Note 2 :  $T_a = 25\text{ }^{\circ}\text{C}$

Note 3 : Brightness to be decreased to 50% of the initial value

Note 4 : The single LED lamp case

## 6. DC CHARACTERISTICS

Parameter	Symbol	Rating			Unit	Condition
		Min.	Typ.	Max.		
Low level input voltage	$V_{IL}$	0	-	$0.3V_{DD}$	V	
High level input voltage	$V_{IH}$	$0.7V_{DD}$	-	$V_{DD}$	V	

# 7. Interface Timing

## 7.1.1 8080 Mode

The 8080 mode MCU interface consist of CS#, D/C#, RD#, WR#, D[23:0] and TE signals (Please refer to Table 6-1 for pin multiplexed with 6800 mode). This interface use WR# to define a write cycle and RD# for read cycle. If the WR# goes low when the CS# signal is low, the data or command will be latched into the system at the rising edge of WR#. Similarly, the read cycle will start when RD# goes low and end at the rising edge of RD#.

## 7.1.2 8080 Mode Write Cycle

Symbol	Parameter	Min	Typ	Max	Unit
$t_{cyc}$	Reference Clock Cycle Time	9	-	-	ns
$t_{PWCSL}$	Pulse width CS# low	1	-	-	$t_{cyc}$
$t_{PWCSH}$	Pulse width CS# high	1	-	-	$t_{cyc}$
$t_{FDRD}$	First Read Data Delay	5	-	-	$t_{cyc}$
$t_{AS}$	Address Setup Time	1	-	-	ns
$t_{AH}$	Address Hold Time	1	-	-	ns
$t_{DSW}$	Data Setup Time	4	-	-	ns
$t_{DHW}$	Data Hold Time	1	-	-	ns
$t_{DSR}$	Data Access Time	-	-	5	ns
$t_{DHR}$	Output Hold time	1	-	-	ns

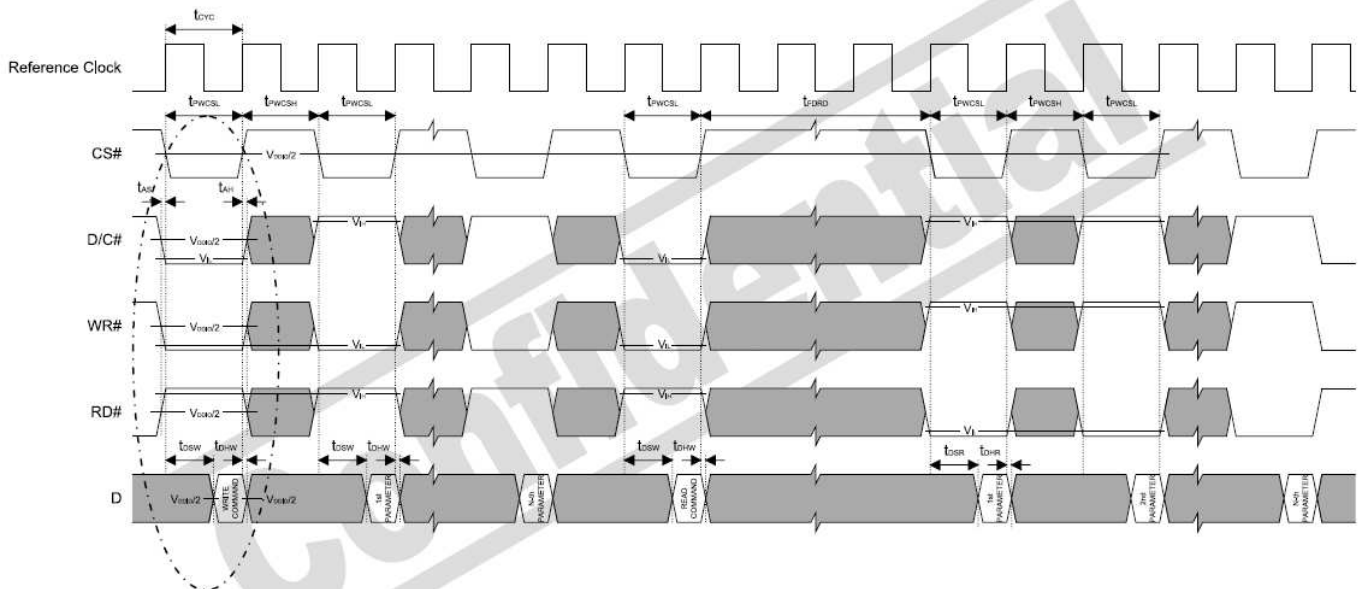

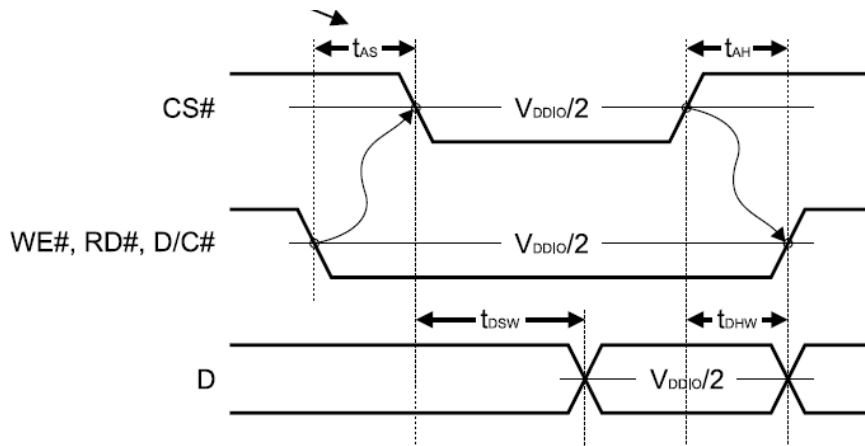

### 7.1.3 Pixel Data Format

Interface	Cycle	D[23]	D[22]	D[21]	D[20]	D[19]	D[18]	D[17]	D[16]	D[15]	D[14]	D[13]	D[12]	D[11]	D[10]	D[9]	D[8]	D[7]	D[6]	D[5]	D[4]	D[3]	D[2]	D[1]	D[0]		
24 bits	1 <sup>st</sup>	R7	R6	R5	R4	R3	R2	R1	R0	G7	G6	G5	G4	G3	G2	G1	G0	B7	B6	B5	B4	B3	B2	B1	B0		
18 bits	1 <sup>st</sup>							R5	R4	R3	R2	R1	R0	G5	G4	G3	G2	G1	G0	B5	B4	B3	B2	B1	B0		
16 bits (565 format)	1 <sup>st</sup>									R5	R4	R3	R2	R1	G5	G4	G3	G2	G1	G0	B5	B4	B3	B2	B1		
16 bits	1 <sup>st</sup>									R5	R4	R3	R2	R1	R0	X	X	G5	G4	G3	G2	G1	G0	X	X		
	2 <sup>nd</sup>									B5	B4	B3	B2	B1	B0	X	X	R5	R4	R3	R2	R1	R0	X	X		
	3 <sup>rd</sup>									G5	G4	G3	G2	G1	G0	X	X	B5	B4	B3	B2	B1	B0	X	X		
9 bits	1 <sup>st</sup>																	R5	R4	R3	R2	R1	R0	G5	G4	G3	
	2 <sup>nd</sup>																	G2	G1	G0	B5	B4	B3	B2	B1	B0	
8 bits	1 <sup>st</sup>																			R5	R4	R3	R2	R1	R0	X	X
	2 <sup>nd</sup>																			G5	G4	G3	G2	G1	G0	X	X
	3 <sup>rd</sup>																			B5	B4	B3	B2	B1	B0	X	X

X: Don't Care



## 8. OPTICAL CHARACTERISTIC

Item	Symbol	Condition.	Min	Typ.	Max.	Unit	Remark	
Response time	Tr	$\theta = 0^\circ$ , $\Phi = 0^\circ$	-	15	30	.ms	Note 3	
	Tf		-	35	50	.ms		
Contrast ratio	CR	At optimized viewing angle	150	200	-	-	Note 4	
Color Chromaticity	White	$\theta = 0^\circ$ , $\Phi = 0$	Wx	0.27	0.32	0.37		Note 2,5
			Wy	0.30	0.35	0.40		
Viewing angle	Hor.	CR $\geq 10$	$\Theta R$	60	70		Deg.	Note 1
			$\Theta L$	60	70			
	Ver.		$\Phi T$	40	50			
			$\Phi B$	60	70			
Brightness	-	-	300	-	-	cd/m <sup>2</sup>	Center of display	

Ta=25±2°C, IL=20mA

Note 1: Definition of viewing angle range

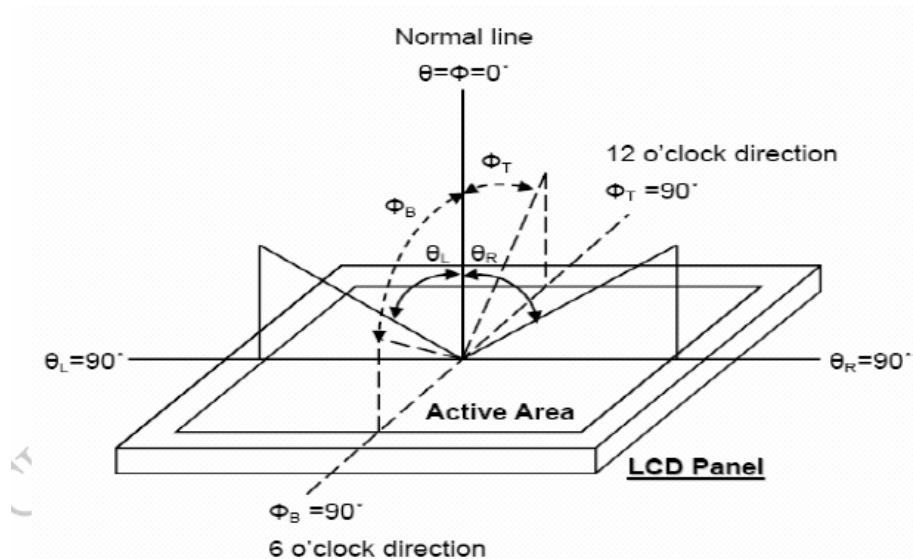

Fig. 8-1 Definition of viewing angle

Note 2: Test equipment setup:

After stabilizing and leaving the panel alone at a driven temperature for 10 minutes, the measurement should be executed. Measurement should be executed in a stable, windless, and dark room. Optical specifications are measured by Topcon BM-7 luminance meter 1.0° field of view at a distance of 50cm and normal direction.

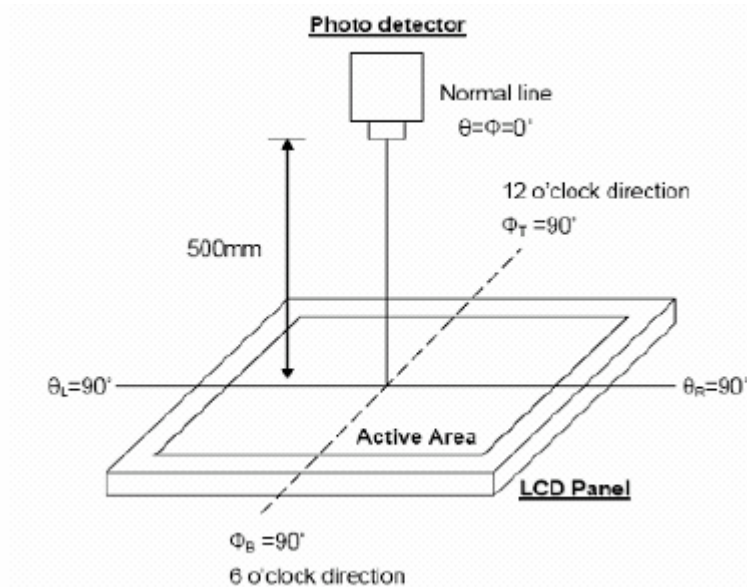

Fig. 8-2 Optical measurement system setup

Note 3: Definition of Response time:

The response time is defined as the LCD optical switching time interval between “White” state and “Black” state. Rise time,  $T_r$ , is the time between photo detector output intensity changed from 90% to 10%. And fall time,  $T_f$ , is the time between photo detector output intensity changed from 10% to 90%.

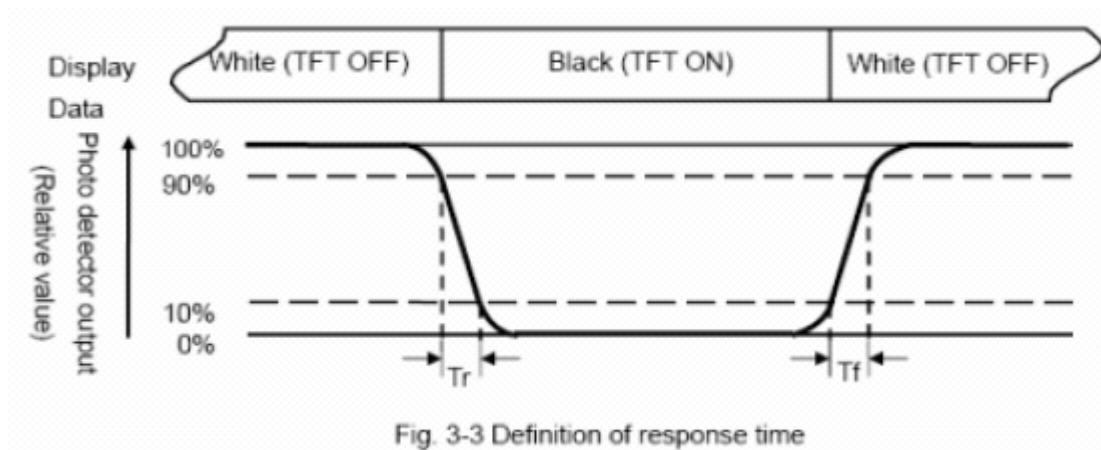

Fig. 3-3 Definition of response time

Note 4: Definition of contrast ratio:

The contrast ratio is defined as the following expression.

$$\text{Contrast ratio (CR)} = \frac{\text{Luminance measured when LCD on the "White" state}}{\text{Luminance measured when LCD on the "Black" state}}$$

Note 5: Definition of color chromaticity (CIE1931)

Color coordinates measured at center point of LCD.

Note 6: All input terminals LCD panel must be ground while measuring the center area of the panel.

## **9. INTERFACE**

### **10.1. LCM PIN Definition**

<b>Pin No.</b>	<b>Symbol</b>	<b>I/O</b>	<b>Description</b>	<b>Remark</b>
1	GND		System ground pin of the IC. Connect to system ground.	
2	VDD		Power Supply : +3.3V	
3	NC		No connection	
4	D/C		Data/Command select	
5	WR		Write strobe signal	
6	RD		Read strobe signal	
7	DB0		Data bus	
8	DB1		Data bus	
9	DB2		Data bus	
10	DB3		Data bus	
11	DB4		Data bus	
12	DB5		Data bus	
13	DB6		Data bus	
14	DB7		Data bus	
15	CS		Chip select	
16	RST		Hardware reset	
17	NC		No connection	
18	RL		Left /right selection	
19	UD		Up/down selection	
20	NC		No connection	

# 10. BLOCK DIAGRAM

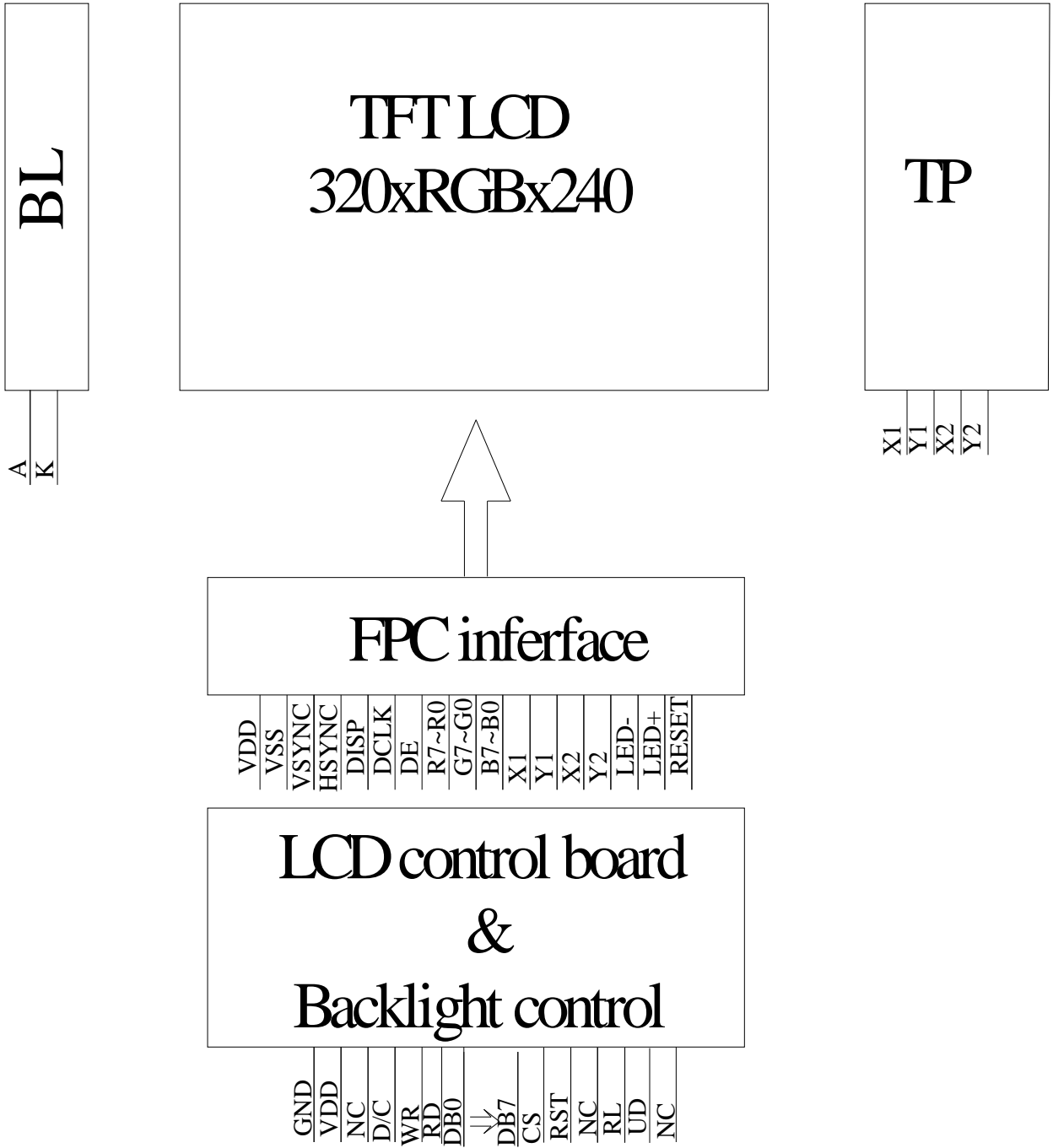

# 11. Contour Drawing

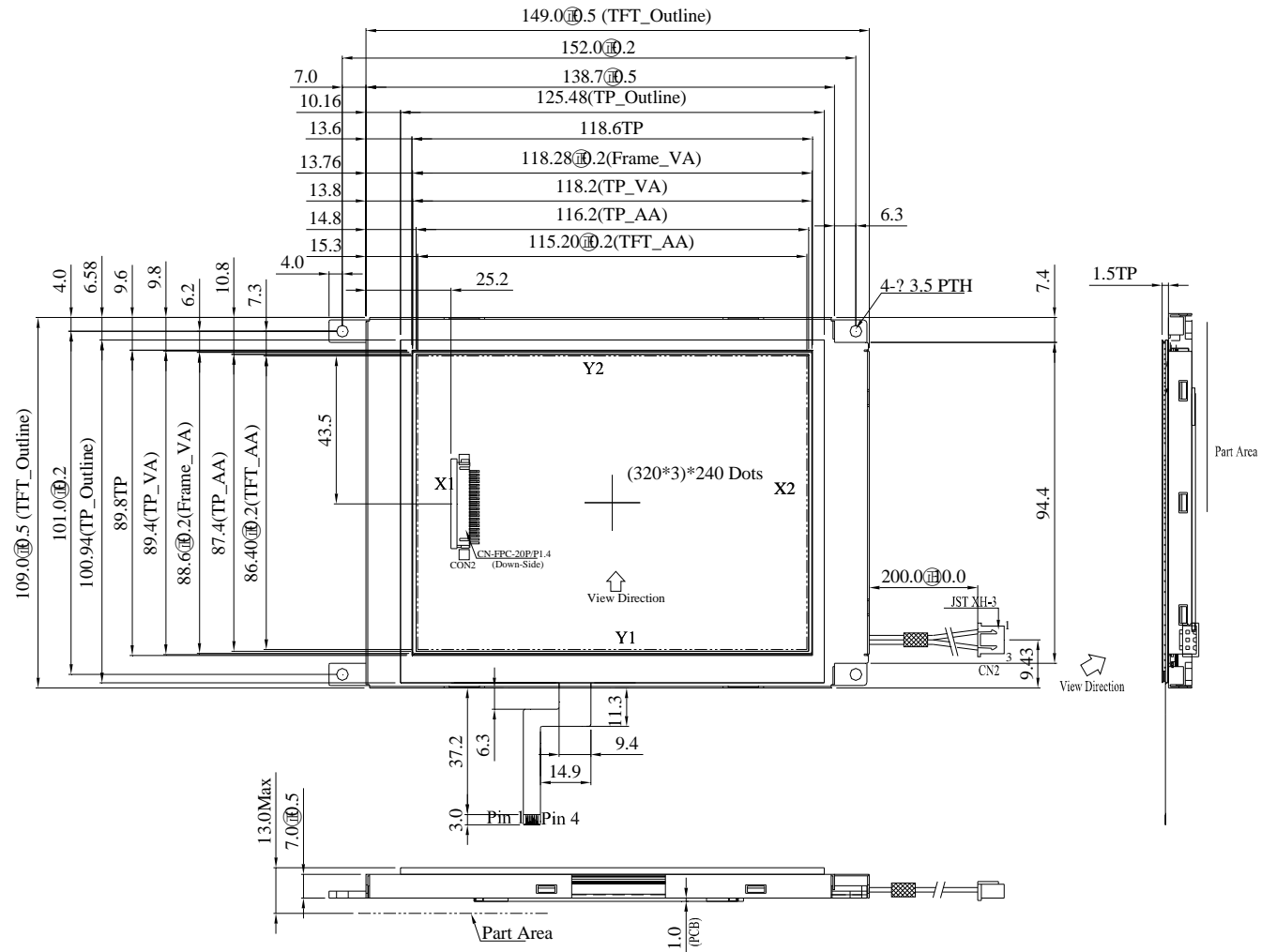

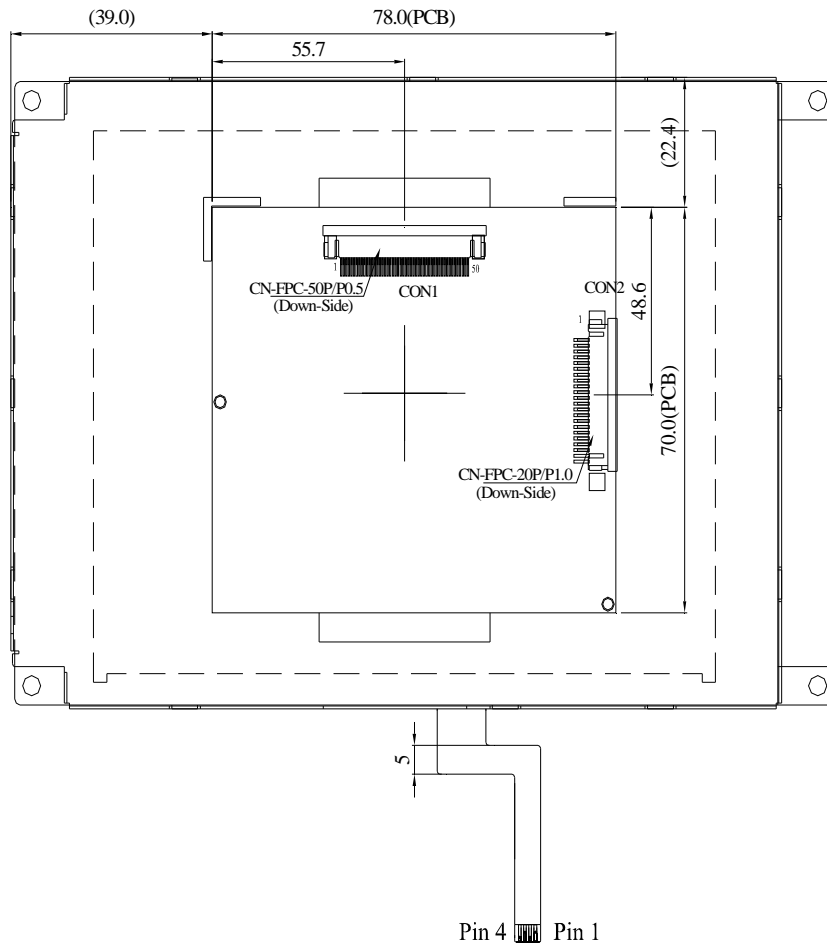

## CON2 8bit mode

PIN NO	SYMBOL	PIN NO	SYMBOL
1	GND	17	NC
2	VDD	18	RL
3	NC	19	UD
4	D/C	20	NC
5	WR		
6	RD		
7	DB0		
8	DB1		
9	DB2		
10	DB3		
11	DB4		
12	DB5		
13	DB6		
14	DB7		
15	CS		
16	RST		

# 12. Touch panel Information

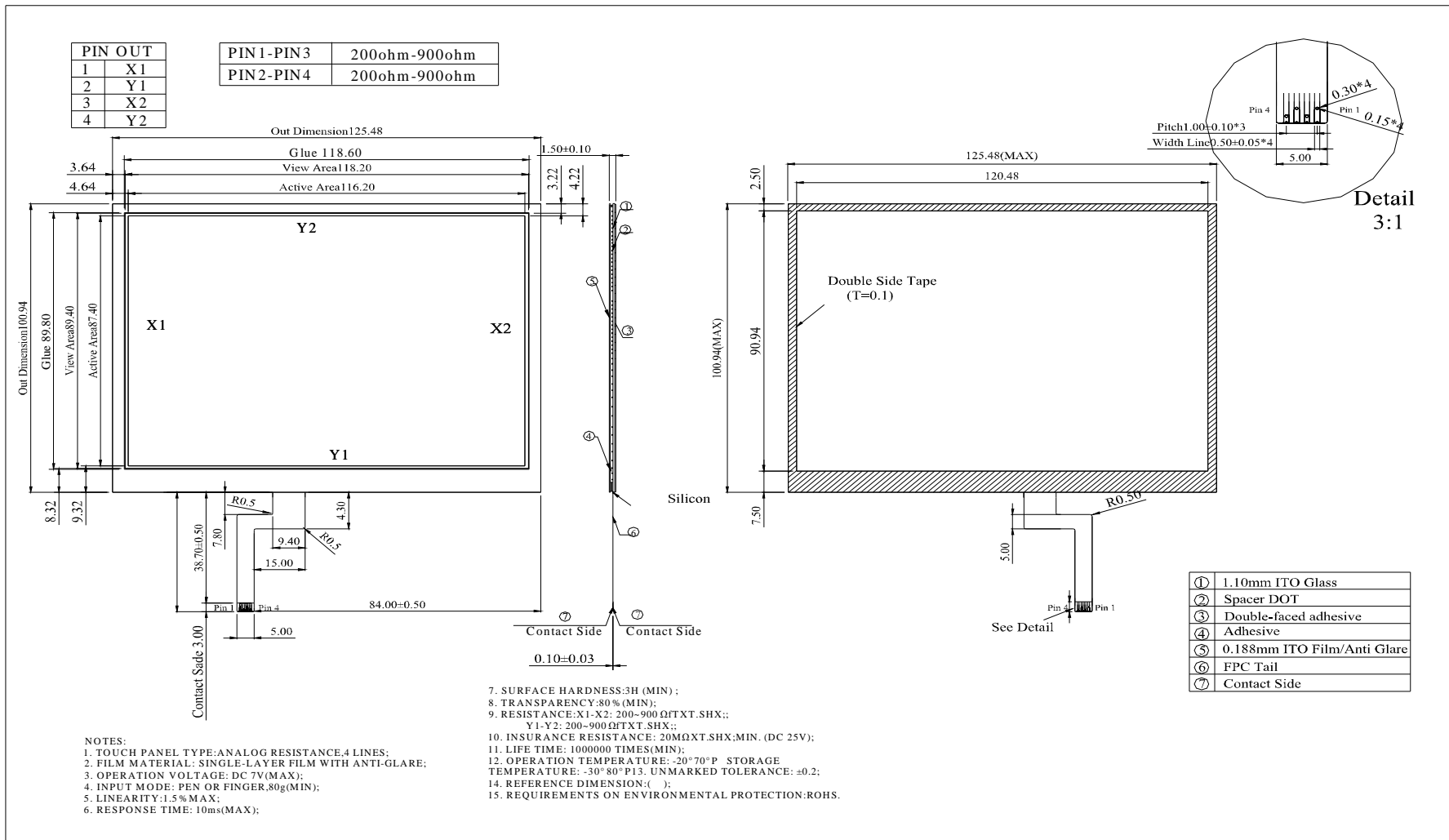

## Non-Proper Ways to handle the touch screen

1. Do not pull or crease the tail of the touch screen.

2. Tails, unless the drawing calls out for a bend, are to be free of permanent creases in the polyester, slight crease lines in the adhesive tail cover are allowed

# 13. Reliability

## Content of Reliability Test (Wide temperature, -20°C~70°C)

Environmental Test			
Test Item	Content of Test	Test Condition	Note
High Temperature storage	Endurance test applying the high storage temperature for a long time.	80°C 200hrs	2
Low Temperature storage	Endurance test applying the high storage temperature for a long time.	-30°C 200hrs	1,2
High Temperature Operation	Endurance test applying the electric stress (Voltage & Current) and the thermal stress to the element for a long time.	70°C 200hrs	—
Low Temperature Operation	Endurance test applying the electric stress under low temperature for a long time.	-20°C 200hrs	1
High Temperature/ Humidity Operation	The module should be allowed to stand at 60°C,90%RH max For 96hrs under no-load condition excluding the polarizer, Then taking it out and drying it at normal temperature.	60°C,90%RH 96hrs	1,2
Thermal shock resistance	The sample should be allowed stand the following 10 cycles of operation  <div style="text-align: center;"> <p style="margin: 0;">-20°C    25°C    70°C</p> <p style="margin: 0;">←—————→</p> <p style="margin: 0;">30min    5min    30min</p> <p style="margin: 0;">1 cycle</p> </div>	-20°C/70°C 10 cycles	—
Vibration test	Endurance test applying the vibration during transportation and using.	Total fixed amplitude : 3 15mm Vibration Frequency : 10~55Hz One cycle 60 seconds to 3 directions of X,Y,Z for Each 15 minutes	3
Static electricity test	Endurance test applying the electric stress to the terminal.	VS=800V,RS=1.5kΩ CS=100pF 1 time	—

**Note1: No dew condensation to be observed.**

**Note2: The function test shall be conducted after 4 hours storage at the normal Temperature and humidity after remove from the test chamber.**

**Note3: Vibration test will be conducted to the product itself without putting it in a container.**



# 14. Package specification

<b>LCM Model</b>	WF57BTIBCDAT0#	<b>LCM 包裝規格書</b> <b>LCM Packaging Specifications</b>	<b>Approve</b>	<b>Check</b>	<b>Contact</b>
<b>Drawing NO.</b>			<b>DATE</b>	<b>初版</b>	<b>版次 Ver</b>
			13'3/29	13'3/29	0
<b>1.包裝材料規格表 (Packaging Material) :(per carton)</b>					
NO.	Item	Model	Dimensions	Quantity	
1	成品 (LCM)	WF57BTIBCDAT0#	<b>TBD</b>	<b>TBD</b>	
2	TRAY 盤 (2)	<b>TBD</b>	<b>TBD</b>	<b>TBD</b>	
3	BP01 內盒(3)Product Box	PK3R1XXXXXXXXXXXX0001	<b>332 x 280 x 100</b>	<b>TBD</b>	
4	泡棉(4)Foam	-----	<b>283 x 230 x 8</b>	<b>TBD</b>	
5	外紙箱(5)Carton	PK4Q1XXXXXXXXXXXX0000	<b>565 x 340 x 320</b>	<b>TBD</b>	
6					
7					
8					
9					
<b>2.單箱數量規格表(Packaging Specifications and Quantity) :</b>					
(1)LCM quantity per box : no per box		<b>TBD</b>	x no of box	<b>TBD</b>	= <b>TBD</b>
(2)Total LCM quantity in carton : quantity per box		<b>TBD</b>	x no of boxes	<b>TBD</b>	= <b>TBD</b>
<b>特 記 事 項 (REMARK)</b>					
1. Label Specifications :					
MOOEL: LOT NO : QUANTITY: CHECK:					

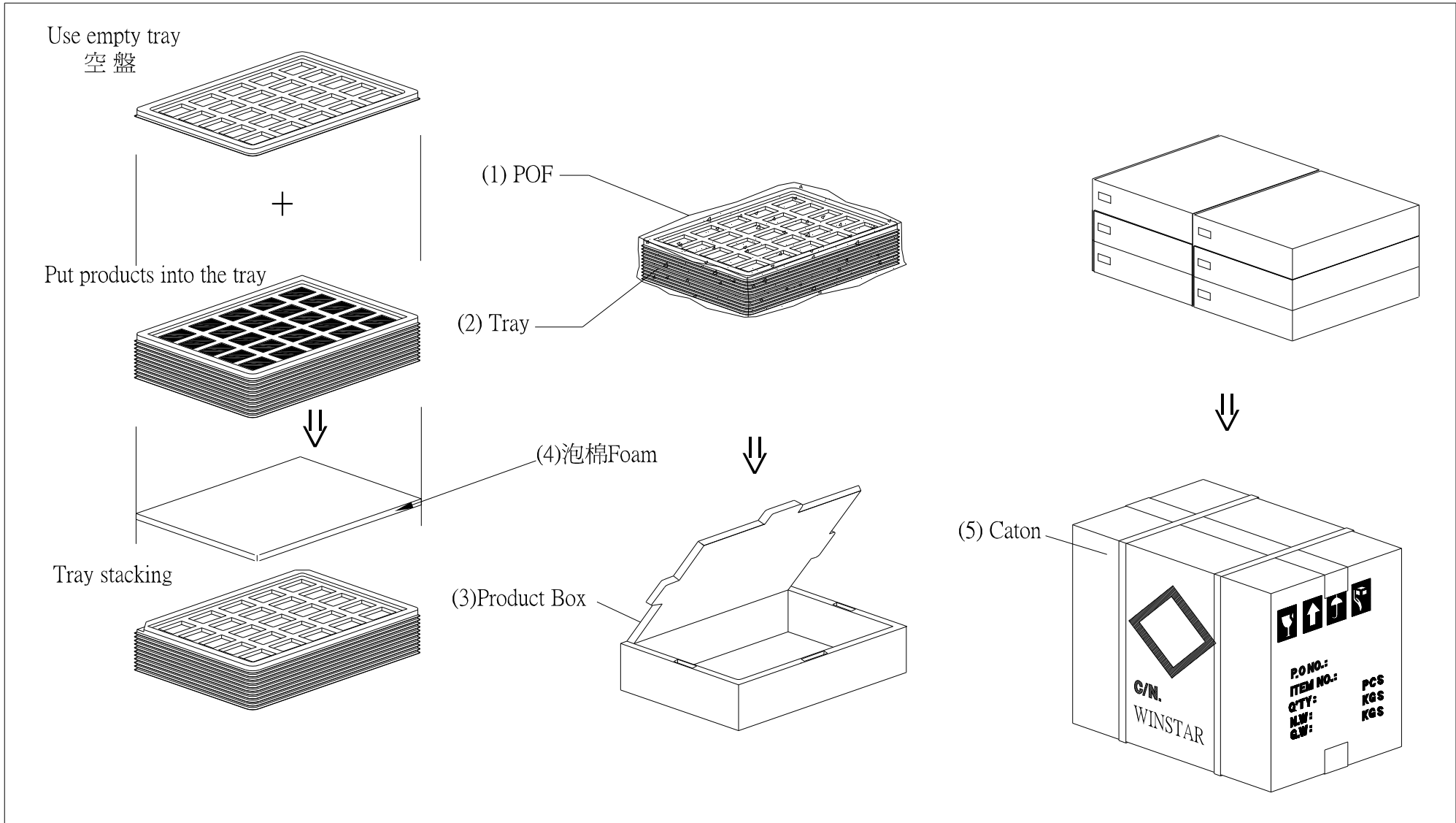

## 15. Initial Code For Reference

```
void Initial_SSD1963()
{

    Write_Command_SSD1963(0x01);
    Delay_ms(10);
    Write_Command_SSD1963(0xe0);    //START PLL
    Write_Parameter_SSD1963(0x01);
    Delay_ms(5);
    Write_Command_SSD1963(0xe0);    //LOCK PLL
    Write_Parameter_SSD1963(0x03);
    Delay_ms(5);

    Write_Command_SSD1963(0xb0); //SET LCD MODE  SET TFT 18Bits MODE
    Write_Parameter_SSD1963(0x0c); //SET TFT MODE & hsync+Vsync+DEN
MODE
    Write_Parameter_SSD1963(0x80); //SET TFT MODE & hsync+Vsync+DEN
MODE

    Write_Parameter_SSD1963(0x01); //SET horizontal size=320-1 HightByte
    Write_Parameter_SSD1963(0x3f); //SET horizontal size=320-1 LowByte
    Write_Parameter_SSD1963(0x00); //SET vertical size=240-1 HightByte
    Write_Parameter_SSD1963(0xef); //SET vertical size=240-1 LowByte
    Write_Parameter_SSD1963(0x00); //SET even/odd line RGB seq.=RGB

    Write_Command_SSD1963(0xf0); //SET pixel data I/F format=8bit
    Write_Parameter_SSD1963(0x00);
    Write_Command_SSD1963(0x3a); // SET R G B format = 6 6 6
    Write_Parameter_SSD1963(0x60);

    //Set the MN of PLL
    Write_Command_SSD1963(0xe2); //100MHz PLL frequency
    Write_Parameter_SSD1963(0x1d); //M
    Write_Parameter_SSD1963(0x02); //N
    Write_Parameter_SSD1963(0x54);

    Write_Command_SSD1963(0xe6); //SET PCLK freq=9MHz; Vsync=60Hz
    Write_Parameter_SSD1963(0x01);
    Write_Parameter_SSD1963(0x40); //55
    Write_Parameter_SSD1963(0xff);
}
```

```

//Set front porch and back porch
Write_Command_SSD1963(0xb4);
Write_Parameter_SSD1963(0x01); //horizontal total period HT
Write_Parameter_SSD1963(0xb8); //HT=
Write_Parameter_SSD1963(0x00); //HPS
Write_Parameter_SSD1963(0x44);
Write_Parameter_SSD1963(0x07); //HPW
Write_Parameter_SSD1963(0x00); //SET Hsync pulse start position
Write_Parameter_SSD1963(0x00); //Set the horizontal sync pulse width (LLINE) in
start.

Write_Parameter_SSD1963(0x00);

Write_Command_SSD1963(0xb6);
Write_Parameter_SSD1963(0x01); //VT=
Write_Parameter_SSD1963(0x08);
Write_Parameter_SSD1963(0x00); //VPS
Write_Parameter_SSD1963(0x13);
Write_Parameter_SSD1963(0x07); //VPW
Write_Parameter_SSD1963(0x00); //FPS
Write_Parameter_SSD1963(0x00);

Write_Command_SSD1963(0x2a); //
Write_Parameter_SSD1963(0x00);//
Write_Parameter_SSD1963(0x00);
Write_Parameter_SSD1963(0x01);//
Write_Parameter_SSD1963(0x3f);

Write_Command_SSD1963(0x2b); //SET page address
Write_Parameter_SSD1963(0x00);//SET start page address=0
Write_Parameter_SSD1963(0x00);
Write_Parameter_SSD1963(0x00);//SET end page address=240
Write_Parameter_SSD1963(0xef);

Write_Command_SSD1963(0x29);
Write_Command_SSD1963(0x2c);
}

```



Module Number : \_\_\_\_\_

Page: 1

**1、Panel Specification :**

- 1. Panel Type :  Pass  NG , \_\_\_\_\_
- 2. View Direction :  Pass  NG , \_\_\_\_\_
- 3. Numbers of Dots :  Pass  NG , \_\_\_\_\_
- 4. View Area :  Pass  NG , \_\_\_\_\_
- 5. Active Area :  Pass  NG , \_\_\_\_\_
- 6. Operating Temperature :  Pass  NG , \_\_\_\_\_
- 7. Storage Temperature :  Pass  NG , \_\_\_\_\_
- 8. Others : \_\_\_\_\_

**2、Mechanical Specification :**

- 1. PCB Size :  Pass  NG , \_\_\_\_\_
- 2. Frame Size :  Pass  NG , \_\_\_\_\_
- 3. Material of Frame :  Pass  NG , \_\_\_\_\_
- 4. Connector Position :  Pass  NG , \_\_\_\_\_
- 5. Fix Hole Position :  Pass  NG , \_\_\_\_\_
- 6. Backlight Position :  Pass  NG , \_\_\_\_\_
- 7. Thickness of PCB :  Pass  NG , \_\_\_\_\_
- 8. Height of Frame to PCB :  Pass  NG , \_\_\_\_\_
- 9. Height of Module :  Pass  NG , \_\_\_\_\_
- 10. Others :  Pass  NG , \_\_\_\_\_

**3、Relative Hole Size :**

- 1. Pitch of Connector :  Pass  NG , \_\_\_\_\_
- 2. Hole size of Connector :  Pass  NG , \_\_\_\_\_
- 3. Mounting Hole size :  Pass  NG , \_\_\_\_\_
- 4. Mounting Hole Type :  Pass  NG , \_\_\_\_\_
- 5. Others :  Pass  NG , \_\_\_\_\_

**4、Backlight Specification :**

- 1. B/L Type :  Pass  NG , \_\_\_\_\_
- 2. B/L Color :  Pass  NG , \_\_\_\_\_
- 3. B/L Driving Voltage (Reference for LED Type) :  Pass  NG , \_\_\_\_\_
- 4. B/L Driving Current :  Pass  NG , \_\_\_\_\_
- 5. Brightness of B/L :  Pass  NG , \_\_\_\_\_
- 6. B/L Solder Method :  Pass  NG , \_\_\_\_\_
- 7. Others :  Pass  NG , \_\_\_\_\_

>> **Go to page 2** <<

Module Number : \_\_\_\_\_

Page: 2

**5、Electronic Characteristics of Module :**

- |                              |                               |                                     |
|------------------------------|-------------------------------|-------------------------------------|
| 1. Input Voltage :           | <input type="checkbox"/> Pass | <input type="checkbox"/> NG , _____ |
| 2. Supply Current :          | <input type="checkbox"/> Pass | <input type="checkbox"/> NG , _____ |
| 3. Driving Voltage for LCD : | <input type="checkbox"/> Pass | <input type="checkbox"/> NG , _____ |
| 4. Contrast for LCD :        | <input type="checkbox"/> Pass | <input type="checkbox"/> NG , _____ |
| 5. B/L Driving Method :      | <input type="checkbox"/> Pass | <input type="checkbox"/> NG , _____ |
| 6. Negative Voltage Output : | <input type="checkbox"/> Pass | <input type="checkbox"/> NG , _____ |
| 7. Interface Function :      | <input type="checkbox"/> Pass | <input type="checkbox"/> NG , _____ |
| 8. LCD Uniformity :          | <input type="checkbox"/> Pass | <input type="checkbox"/> NG , _____ |
| 9. ESD test :                | <input type="checkbox"/> Pass | <input type="checkbox"/> NG , _____ |
| 10. Others :                 | <input type="checkbox"/> Pass | <input type="checkbox"/> NG , _____ |

**6、Summary :**

Sales signature : \_\_\_\_\_

Customer Signature : \_\_\_\_\_

Date : \_\_\_\_ / \_\_\_\_ / \_\_\_\_