

Optoelectronic Devices

Order code	Manufacturer code	Description
58-0524	TLP620	TLP620 SINGLE OPTOISOLATOR
58-0526	TLP620-4	TLP620-4 QUAD OPTOISOLATOR

Optoelectronic Devices	Page 1 of 9
The enclosed information is believed to be correct, Information may change 'without notice' due to product improvement. Users should ensure that the product is suitable for their use. E. & O. E.	Revision A 04/07/2003

SEMICONDUCTOR
TOSHIBA
 TECHNICAL DATA

TOSHIBA PHOTOCOUPLER
TLP620, TLP620-2, TLP620-4
 GaAs IRED & PHOTO-TRANSISTOR

(TLP620)
 PROGRAMMABLE CONTROLLERS
 AC/DC-INPUT MODULE
 TELECOMMUNICATION

The TOSHIBA TLP620, -2 and -4 consists of a photo-transistor optically coupled to two gallium arsenide infrared emitting diode connected in inverse parallel.
 The TLP620-2 offers two isolated channels in an eight lead plastic DIP package, while the TLP620-4 provides four isolated channels in a sixteen plastic DIP package.

- Collector-Emitter Voltage : 55V (Min.)
 - Current Transfer Ratio : 50% (Min.)
- Rank GB : 100% (Min.)

PIN CONFIGURATIONS (TOP VIEW)

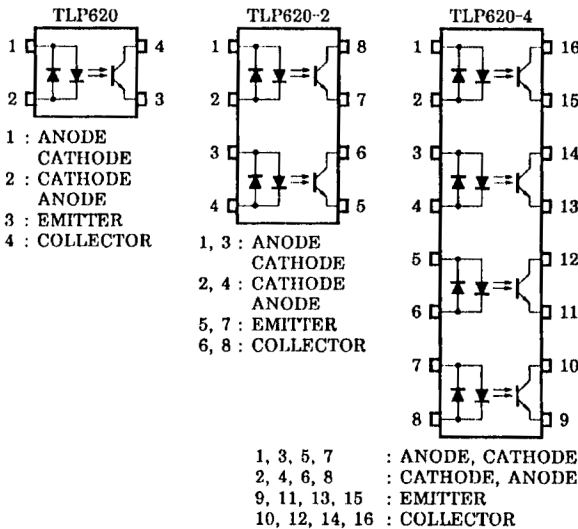

Unit in mm

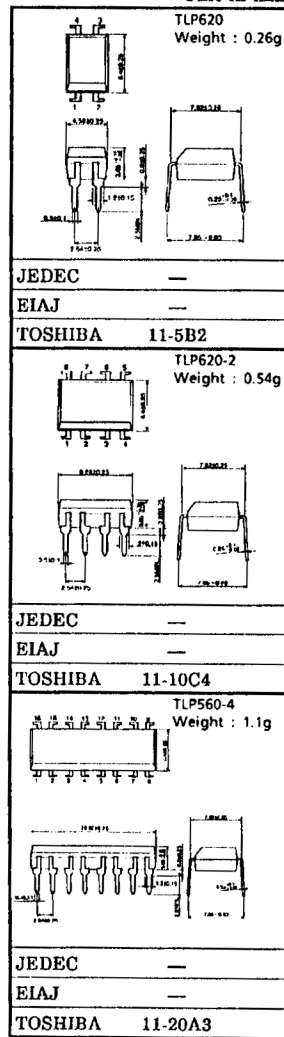

① The information contained herein is presented only as a guide for the applications of our products. No responsibility is assumed by TOSHIBA CORPORATION for any infringements of intellectual property or other rights of the third parties which may result from its use. No license is granted by implication or otherwise under any intellectual property or other rights of TOSHIBA CORPORATION or others.
 ② These TOSHIBA products are intended for use in general commercial applications (office equipment, communication equipment, measuring equipment, domestic appliances, etc.) please make sure that you consult with us before you use these TOSHIBA products in equipment which requires extraordinarily high quality and/or reliability, and in equipment which may involve life threatening or critical application, including but not limited to such uses as atomic energy control, airplane or space-ship instrumentation, traffic signals, medical instrumentation, combustion control, all types of safety devices, etc. TOSHIBA cannot accept and hereby disclaims liability for any damage which may occur in case the TOSHIBA products are used in such equipment or applications without prior consultation with TOSHIBA.

(TLP620)

- UL Recognized : UL1577, File No. E67349
- Isolation Voltage : 5000V_{rms} (Min.)
- Option (D4) type
 VDE Approved : DIN VDE0884 / 08.87, Certificate No. 68384
 Maximum Operating Insulation Voltage : 630V_{PK}
 Highest Permissible Over Voltage : 6000V_{PK}

(Note) When a VDE0884 approved type is needed, please designate the "Option (D4)".

- Creepage Distance : 6.4mm (Min.)
- Clearance : 6.4mm (Min.)
- Insulation Thickness : 0.4mm (Min.)

MAXIMUM RATINGS (Ta = 25°C)

CHARACTERISTIC		SYMBOL	RATING		UNIT
			TLP620	TLP620-2 TLP620-4	
LED	Forward Current	I _F (RMS)	60	50	mA
	Forward Current Derating	ΔI _F / °C	-0.7 (Ta ≥ 39°C)	-0.5 (Ta ≥ 25°C)	mA / °C
	Pulse Forward Current	I _{FP}	1 (100μs pulse, 100pps)		A
	Power Dissipation (1 Circuit)	P _D	100	70	mW
	Power Dissipation Derating	ΔP _D / °C	-1.0	-0.7	mW / °C
	Junction Temperature	T _j	125		°C
DETECTOR	Collector-Emitter Voltage	V _{CEO}	55		V
	Emitter-Collector Voltage	V _{ECO}	7		V
	Collector Current	I _C	50		mA
	Collector Power Dissipation (1 Circuit)	P _C	150	100	mW
	Collector Power Dissipation Derating (1 Circuit) (Ta ≥ 25°C)	ΔP _C / °C	-1.5	-1.0	mW / °C
	Junction Temperature	T _j	125		°C
Storage Temperature Range	T _{stg}	-55~150		°C	
Operating Temperature Range	T _{opr}	-55~100		°C	
Lead Soldering Temperature	T _{sold}	260 (10s)		°C	
Total Package Power Dissipation	P _T	250	150	mW	
Total Package Power Dissipation Derating (Ta ≥ 25°C, 1 Circuit)	ΔP _T / °C	-2.5	-1.5	mW / °C	
Isolation Voltage	BV _S	5000 (AC, 1 min., RH ≤ 60%)		V _{rms}	

TLP620 - 2
 1996 - 4 - 8
TOSHIBA CORPORATION

(TLP620)

INDIVIDUAL ELECTRICAL CHARACTERISTICS (Ta = 25°C)

CHARACTERISTIC		SYMBOL	TEST CONDITION	MIN.	TYP.	MAX.	UNIT
LED	Forward Voltage	V _F	I _F = ±10mA	1.0	1.15	1.3	V
	Forward Current	I _F	V _F = ±0.7V	—	2.5	20	μA
	Capacitance	C _T	V = 0, f = 1MHz	—	60	—	pF
DETECTOR	Collector-Emitter Breakdown Voltage	V _{(BR) CEO}	I _C = 0.5mA	55	—	—	V
	Emitter-Collector Breakdown Voltage	V _{(BR) ECO}	I _E = 0.1mA	7	—	—	V
	Collector Dark Current	I _{CEO}	V _{CE} = 24V	—	10	100	nA
			V _{CE} = 24V, Ta = 85°C	—	2	50	μA
Capacitance (Collector to Emitter)	C _{CE}	V _{CE} = 0, f = 1MHz	—	10	—	pF	

COUPLED ELECTRICAL CHARACTERISTICS (Ta = 25°C)

CHARACTERISTIC	SYMBOL	TEST CONDITION	MIN.	TYP.	MAX.	UNIT
Current Transfer Ratio	I _C / I _F	I _F = ±5mA, V _{CE} = 5V Rank GB	50	—	600	%
			100	—	600	
Saturated CTR	I _C / I _F (sat)	I _F = ±1mA, V _{CE} = 0.4V Rank GB	—	60	—	%
			30	—	—	
Collector-Emitter Saturation Voltage	V _{CE} (sat)	I _C = 2.4mA, I _F = ±8mA	—	—	0.4	V
		I _C = 0.2mA, I _F = ±1mA Rank GB	—	0.2	—	
			—	—	0.4	
Off-State Collector Current	I _C (off)	V _F = ±0.7V, V _{CE} = 24V	—	1	10	μA
CTR Symmetry	I _C (ratio)	I _C (I _F = -5mA) / I _C (I _F = +5mA)	0.33	1	3	—

ISOLATION CHARACTERISTICS (Ta = 25°C)

CHARACTERISTIC	SYMBOL	TEST CONDITION	MIN.	TYP.	MAX.	UNIT
Capacitance Input to Output	C _S	V _S = 0, f = 1MHz	—	0.8	—	pF
Isolation Resistance	R _S	V _S = 500V	5 × 10 ¹⁰	10 ¹⁴	—	Ω
Isolation Voltage	BV _S	AC, 1 minute	5000	—	—	V _{rms}
		AC, 1 second, in oil	—	10000	—	
		DC, 1 minute, in oil	—	10000	—	V _{dc}

TLP620 - 3

1996 - 4 - 8

TOSHIBA CORPORATION

(TLP620)

SWITCHING CHARACTERISTICS (Ta = 25°C)

CHARACTERISTIC	SYMBOL	TEST CONDITION	MIN.	TYP.	MAX.	UNIT
Rise Time	t_r	$V_{CC}=10V$ $I_C=2mA$ $R_L=100\Omega$	—	2	—	μs
Fall Time	t_f		—	3	—	
Turn-on Time	t_{on}		—	3	—	
Turn-off Time	t_{off}		—	3	—	
Turn-on Time	t_{ON}	$R_L=1.9k\Omega$ (Fig.1) $V_{CC}=5V, I_F=\pm 16mA$	—	2	—	μs
Storage Time	t_s		—	15	—	
Turn-off Time	t_{OFF}		—	25	—	

RECOMMENDED OPERATING CONDITIONS

CHARACTERISTIC	SYMBOL	MIN.	TYP.	MAX.	UNIT
Supply Voltage	V_{CC}	—	5	24	V
Forward Current	I_F (RMS)	—	16	20	mA
Collector Current	I_C	—	1	10	mA
Operating Temperature	T_{opr}	-25	—	85	°C

Fig.1 Switching Time Test Circuit

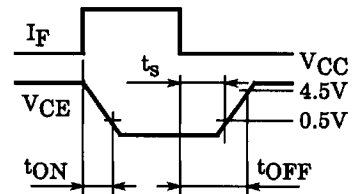
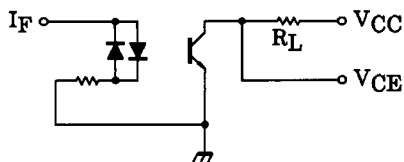

(TLP620)

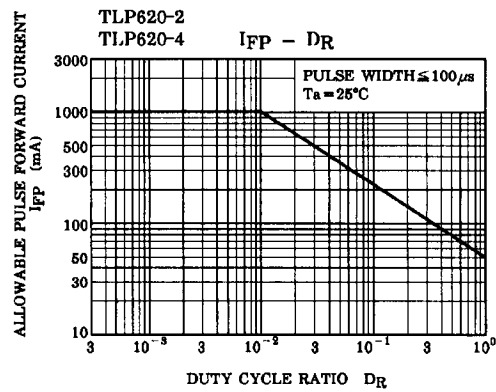
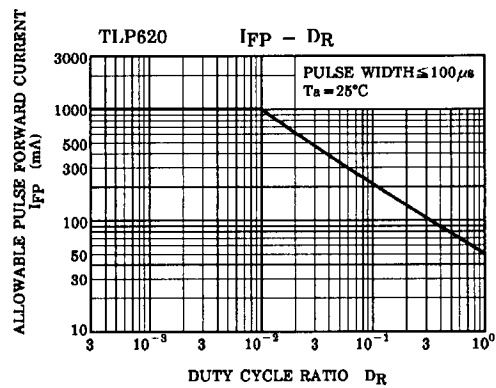
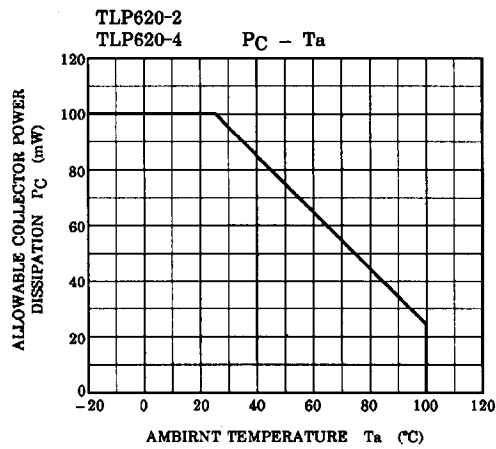
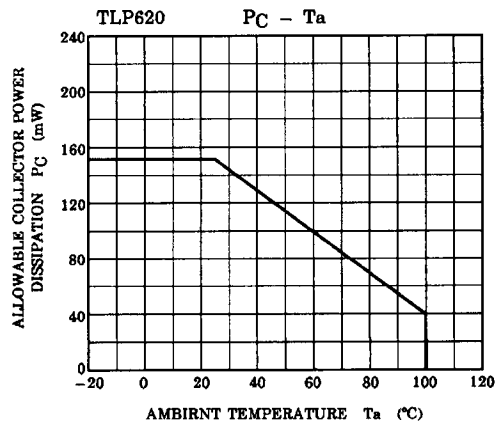
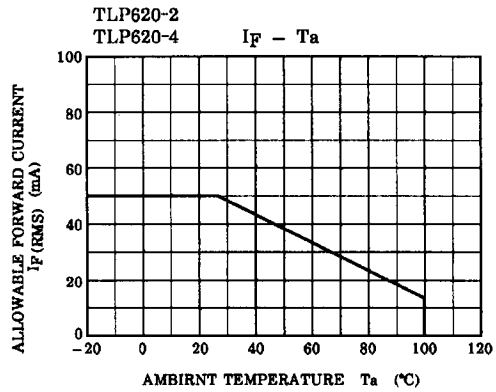
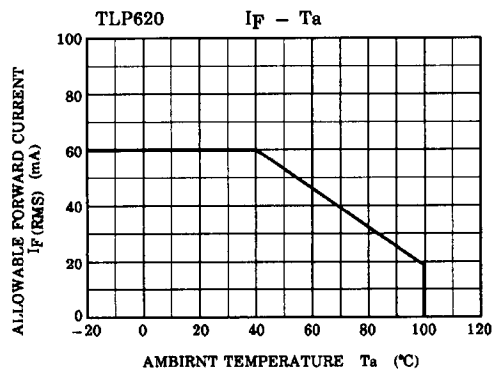

(TLP620)

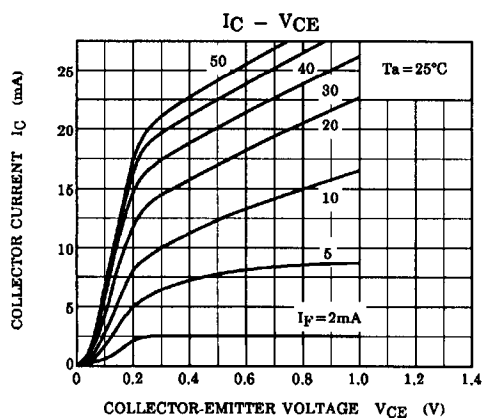
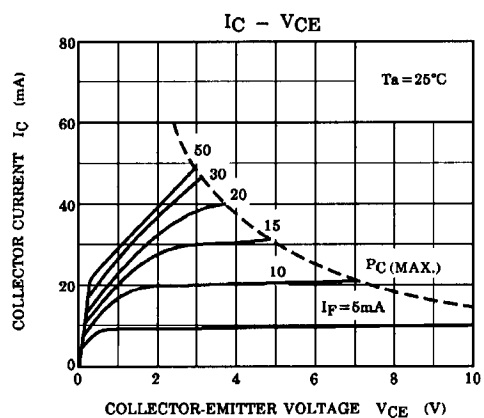
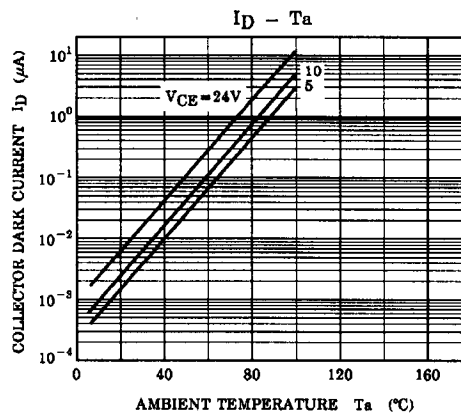
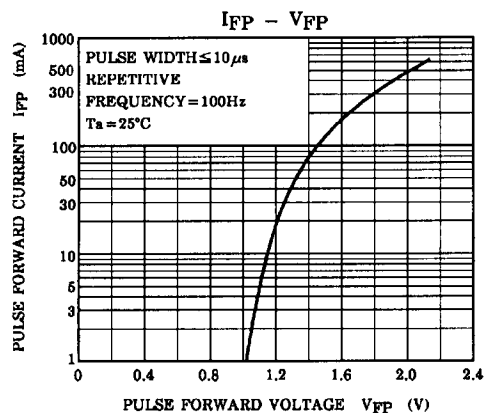
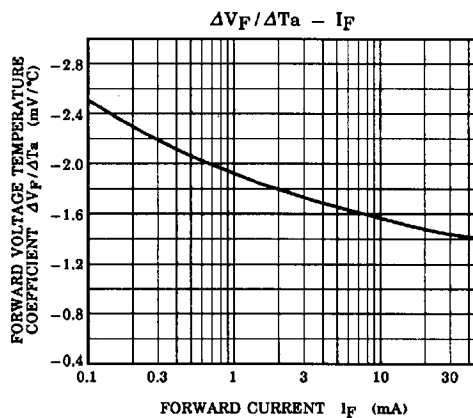
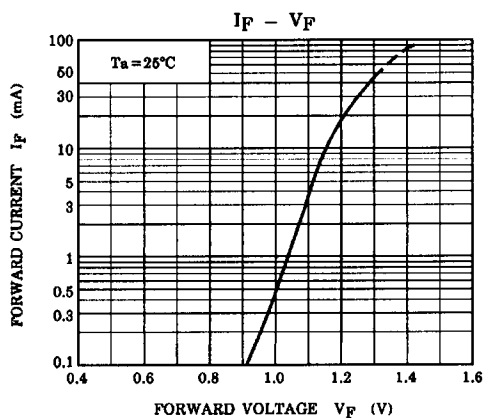

(TLP620)

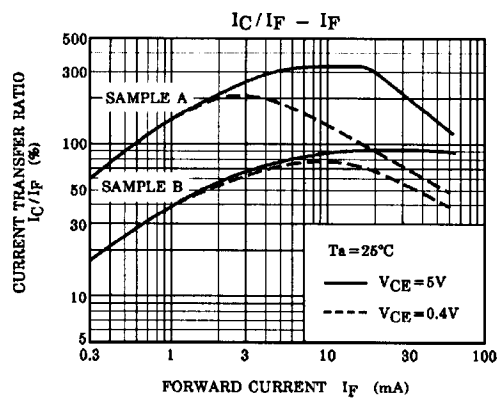
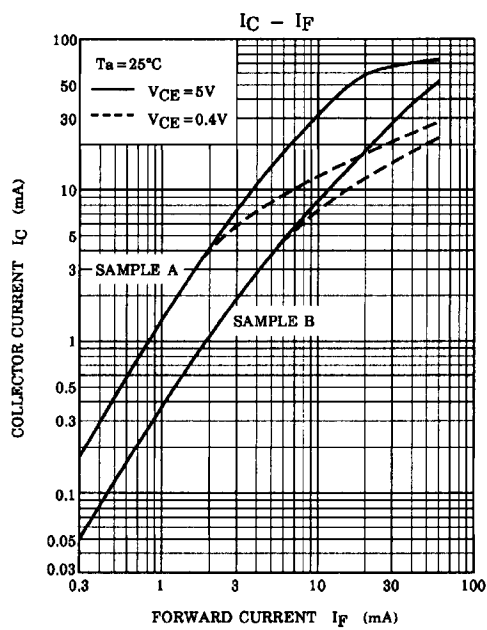
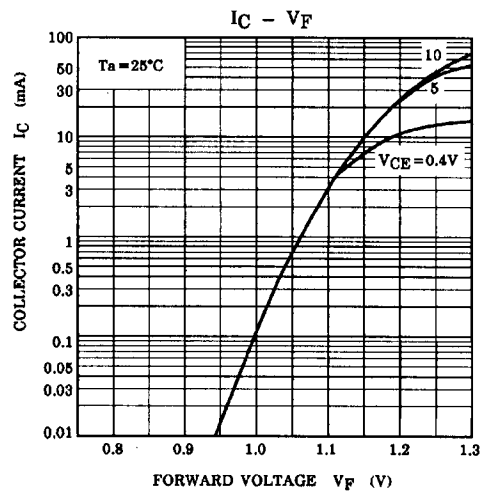
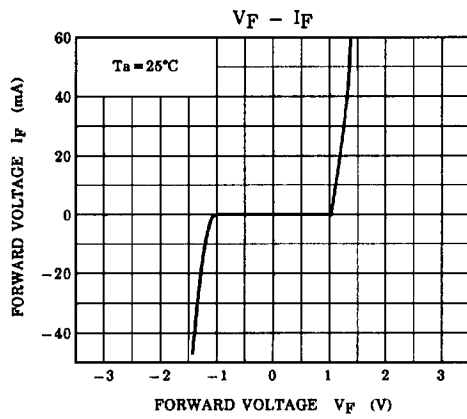

(TLP620)

