

PCB relays

Order code	Manufacturer code	Description
60-4260	TX2-5	COMPACT RELAY DPCO 2A-5V COIL
60-4265	TX2-12	COMPACT RELAY DPCO 2A-12V COIL
60-4270	TX2-24	COMPACT RELAY DPCO 2A-24V COIL

PCB relays	Page 1 of 9
The enclosed information is believed to be correct, Information may change 'without notice' due to product improvement. Users should ensure that the product is suitable for their use. E. & O. E.	Revision A 04/07/2003

NAIS

**2 AMP. HIGH CAPACITY
RELAY WITH HIGH SURGE
VOLTAGE & HIGH BREAK-
DOWN VOLTAGE**

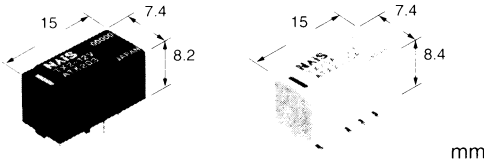
TX-RELAYS

UL File No.: E43149 CSA File No.: LR26550

- Breakdown voltage between contacts and coil: 2,000 V
- Surge withstand between contacts and coil: 2,500 V
- High contact capacity: 2 A 30 V DC
- Surface-mount type available

SPECIFICATIONS**Contact**

Arrangement	2 Form C	
Initial contact resistance, max. (By voltage drop 6 V DC 1 A)	100 mΩ	
Contact material	Gold-clad silver alloy	
Rating	Nominal switching capacity (resistive load)	2 A 30 V DC
	Max. switching power (resistive load)	60 W
	Max. switching voltage	220 V DC
	Max. switching current	2 A
	Min. switching capacity	10 μA 10 mV DC
Nominal operating power	Single side stable	140 mW (1.5 to 24 V DC) 270 mW (48 V DC)
	1 coil latching	100 mW (1.5 to 24 V DC)
	2 coil latching	200 mW (1.5 to 24 V DC)
UL/CSA rating	2 A 30 V DC 0.3 A 110 V DC 0.5 A 125 V AC	
Expected life (min. operations)	Mechanical (at 180 cpm)	10 ⁸
	Electrical (at 20 cpm)	2 A 30 V DC resistive
		1 A 30 V DC resistive

Remarks:

- *1 Measurement at same location as "Initial breakdown voltage" section.
 *2 By resistive method; nominal voltage applied to the coil; contact carrying current: 2 A.
 *3 Nominal voltage applied to the coil, excluding contact bounce time.
 *4 Nominal voltage applied to the coil, excluding contact bounce time without diode.
 *5 Half-wave pulse of sine wave: 6 msec.; detection time: 10 μsec.
 *6 Half-wave pulse of sine wave: 6 msec.
 *7 Detection time: 10 μsec.

Characteristics

Initial insulation resistance *1	Min. 1,000 MΩ (at 500 V DC)	
Initial breakdown voltage	Between open contacts	1,000 Vrms for 1min. (Detection current : 10 mA)
	Between contact sets	1,000 Vrms for 1min. (Detection current : 10 mA)
	Between contact and coil	2,000 Vrms for 1min. (Detection current : 10 mA)
Initial surge voltage	Between open contacts (10×160 μsec.)	1,500 V (FCC Part 68)
	Between contacts and coil (2×10 μsec.)	2,500 V (Bellcore)
Temperature rise *2 (at 20°C)	Max. 50°C	
Operate time [Set time] *3 (at 20°C)	Max. 4 msec. (Approx. 2 msec.) [Max. 4 msec. (Approx. 2 msec.)]	
Release time [Reset time] *4 (at 20°C)	Max. 4 msec. (Approx. 1 msec.) [Max. 4 msec. (Approx. 2 msec.)]	
Shock resistance	Functional *5	Min. 750 m/s ² {75 G}
	Destructive *6	Min. 1,000 m/s ² {100 G}
Vibration resistance	Functional *7	196 m/s ² {20 G}, 10 to 55 Hz at double amplitude of 3.3 mm
	Destructive	294 m/s ² {30 G}, 10 to 55 Hz at double amplitude of 5 mm
Conditions for operation, transport and storage (Not freezing and condensing at low temperature)	Ambient temperature	-40°C to +85°C (up to 24 V coil)
		-40°C to +70°C (48 V coil)
	Humidity	5 to 85% R.H.
Unit weight	Approx. 2 g	

ORDERING INFORMATION

Ex. TX 2 SA L H 3V Z

Contact arrangement	Surface-mount availability	Operating function	Terminal shape	Coil voltage (DC)	Packing style
2: 2 Form C	Nil: Standard PC board terminal type or self-clinching terminal type SA: Standard surface-mount terminal type SL: High connection reliability surface-mount terminal type SS: Space saving surface-mount terminal type	Nil: Single side stable L: 1 coil latching L2: 2 coil latching LT: 2 coil latching type with different terminal layout.	Nil: Standard PC board terminal or surface-mount terminal H: Self-clinching terminal	1.5, 3, 4.5, 5, 6, 9, 12, 24, 48* V	Nil: Tube packing Z: Tape and reel packing (piked from the 8/9/10/12-pin side)

Notes: 1. Tape and reel (picked from 1/3/4/5-pin side) is also available by request. Part number suffix "-X" is needed when ordering.
(ex.) TX2SA-3 V-X

*48V coil type: Single side stable only

2. Tape and reel packing symbol "-Z" or "-X" are not marked on the relay.

Surface-mount terminal variation

Variation	Terminal style	Usable conditions based on terminal connection solder reliability	
		Normal environments(indoor)	Drastic temperature fluctuations(outdoor)
SA type (Standard surface-mount terminal type)		Recommended	—
SL type (Highly connection reliability surface-mount terminal type)		Recommended	Recommended
SS type (Space saving surface-mount terminal type)		Recommended	Recommended

TYPES AND COIL DATA (at 20°C 68°F)

1) Standard PC board terminal type and self-clinching terminal type

Operating function	Part No.		Nominal voltage, V DC	Pick-up voltage, V DC (max.)	Drop-out voltage, V DC (min.)	Nominal operating current, mA (±10%)	Coil resistance, Ω (±10%)	Nominal operating power, mW	Max. allowable voltage, V DC
	Standard PC board terminal	Self-clinching terminal							
Single side stable	TX2-1.5V	TX2-H-1.5V	1.5	1.13	0.15	93.8	16	140	2.2
	TX2-3V	TX2-H-3V	3	2.25	0.3	46.7	64.3	140	4.5
	TX2-4.5V	TX2-H-4.5V	4.5	3.38	0.45	31	145	140	6.7
	TX2-5V	TX2-H-5V	5	3.75	0.5	28.1	178	140	7.5
	TX2-6V	TX2-H-6V	6	4.5	0.6	23.3	257	140	9
	TX2-9V	TX2-H-9V	9	6.75	0.9	15.5	579	140	13.5
	TX2-12V	TX2-H-12V	12	9	1.2	11.7	1,028	140	18
	TX2-24V	TX2-H-24V	24	18	2.4	5.8	4,114	140	36
TX2-48V	TX2-H-48V	48	36	4.8	5.6	8,533	270	57.6	

Operating function	Part No.		Nominal voltage, V DC	Set voltage, V DC (max.)	Reset voltage, V DC (Max.)	Nominal operating current, mA (±10%)	Coil resistance, Ω (±10%)	Nominal operating power, mW	Max. allowable voltage, V DC
	Standard PC board terminal	Self-clinching terminal							
1 coil latching	TX2-L-1.5V	TX2-L-H-1.5V	1.5	1.13	1.13	66.7	22.5	100	2.2
	TX2-L-3V	TX2-L-H-3V	3	2.25	2.25	33.3	90	100	4.5
	TX2-L-4.5V	TX2-L-H-4.5V	4.5	3.38	3.38	22.2	202.5	100	6.7
	TX2-L-5V	TX2-L-H-5V	5	3.75	3.75	20	250	100	7.5
	TX2-L-6V	TX2-L-H-6V	6	4.5	4.5	16.7	360	100	9
	TX2-L-9V	TX2-L-H-9V	9	6.75	6.75	11.1	810	100	13.5
	TX2-L-12V	TX2-L-H-12V	12	9	9	8.3	1,440	100	18
	TX2-L-24V	TX2-L-H-24V	24	18	18	4.2	5,760	100	36
2 coil latching	TX2-L2-1.5V	TX2-L2-H-1.5V	1.5	1.13	1.13	133.9	11.2	200	2.2
	TX2-L2-3V	TX2-L2-H-3V	3	2.25	2.25	66.7	45	200	4.5
	TX2-L2-4.5V	TX2-L2-H-4.5V	4.5	3.38	3.38	44.5	101.2	200	6.7
	TX2-L2-5V	TX2-L2-H-5V	5	3.75	3.75	40	125	200	7.5
	TX2-L2-6V	TX2-L2-H-6V	6	4.5	4.5	33.3	180	200	9
	TX2-L2-9V	TX2-L2-H-9V	9	6.75	6.75	22.2	405	200	13.5
	TX2-L2-12V	TX2-L2-H-12V	12	9	9	16.7	720	200	18
	TX2-L2-24V	TX2-L2-H-24V	24	18	18	8.3	2,880	200	36

Notes: 1. Specified value of pick-up, drop-out, set and reset voltage is with the condition of square wave coil pulse.

2. Standard packing: Tube: 40 pcs.; Case: 1,000 pcs.

3. In case of 5 V transistor drive circuit, it is recommended to use 4.5 V type relay.

2) Surface-mount terminal type

Operating function	Part No.	Nominal voltage, V DC	Pick-up voltage, V DC (max.)	Drop-out voltage, V DC (min.)	Nominal operating current, mA ($\pm 10\%$)	Coil resistance, Ω ($\pm 10\%$)	Nominal operating power, mW	Max. allowable voltage, V DC
Single side stable	TX2S○-1.5 V	1.5	1.13	0.15	93.8	16	140	2.2
	TX2S○-3 V	3	2.25	0.3	46.7	64.3	140	4.5
	TX2S○-4.5 V	4.5	3.38	0.45	31	145	140	6.7
	TX2S○-5 V	5	3.75	0.5	28.1	178	140	7.5
	TX2S○-6 V	6	4.5	0.6	23.3	257	140	9
	TX2S○-9 V	9	6.75	0.9	15.5	579	140	13.5
	TX2S○-12 V	12	9	1.2	11.7	1,028	140	18
	TX2S○-24 V	24	18	2.4	5.8	4,114	140	36
	TX2S○-48V	48	36	4.8	5.6	8,533	270	57.6

Operating function	Part No.	Nominal voltage, V DC	Set voltage, V DC (max.)	Reset voltage, V DC (max.)	Nominal operating current, mA ($\pm 10\%$)	Coil resistance, Ω ($\pm 10\%$)	Nominal operating power, mW	Max. allowable voltage, V DC
1 coil latching	TX2S○-L-1.5 V	1.5	1.13	1.13	66.7	22.5	100	2.2
	TX2S○-L-3 V	3	2.25	2.25	33.3	90	100	4.5
	TX2S○-L-4.5 V	4.5	3.38	3.38	22.2	202.5	100	6.7
	TX2S○-L-5 V	5	3.75	3.75	20	250	100	7.5
	TX2S○-L-6 V	6	4.5	4.5	16.7	360	100	9
	TX2S○-L-9 V	9	6.75	6.75	11.1	810	100	13.5
	TX2S○-L-12 V	12	9	9	8.3	1,440	100	18
	TX2S○-L-24 V	24	18	18	4.2	5,760	100	36
2 coil latching	TX2S○-L2-1.5 V	1.5	1.13	1.13	133.9	11.2	200	2.2
	TX2S○-L2-3 V	3	2.25	2.25	66.7	45	200	4.5
	TX2S○-L2-4.5 V	4.5	3.38	3.38	44.5	101.2	200	6.7
	TX2S○-L2-5 V	5	3.75	3.75	40	125	200	7.5
	TX2S○-L2-6 V	6	4.5	4.5	33.3	180	200	9
	TX2S○-L2-9 V	9	6.75	6.75	22.2	405	200	13.5
	TX2S○-L2-12 V	12	9	9	16.7	720	200	18
	TX2S○-L2-24 V	24	18	18	8.3	2,880	200	36

○: For each surface-mounted terminal variation, input the following letter.

SA type: A, SL type: L, SS type: S

Notes: 1. Specified value of pick-up, drop-out, set and reset voltage is with the condition of square wave coil pulse.

2. Standard packing: Tube: 40 pcs. ; Case: 1,000 pcs.

3. Tape and reel packing is also available for surface-mount type by request. Part number suffix "X" or "Z" is needed when ordering.

In this case, "X" or "Z" are not marked on the relay.

Quantity in tape and reel: 500 pcs.

(ex.) • TX2SA-3V-X

• TX2SA-L-3V-Z

└ Picked from the 1/3/4/5-pin side

└ Picked from the 8/9/10/12-pin side

4. In case of 5 V transistor drive circuit, it is recommended to use 4.5 V type relay.

DIMENSIONS

1. Single side stable and 1 coil latching type

Standard PC board terminal

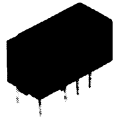

Self clinching terminal



Surface-mount terminal
SA type

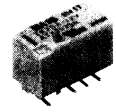

SL type

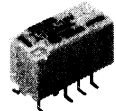

SS type

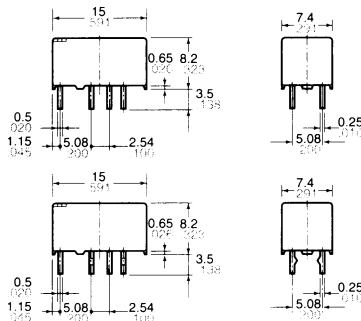
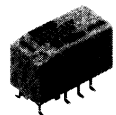

General tolerance: $\pm 0.3 \pm 0.12$

PC board pattern
(Copper side view)

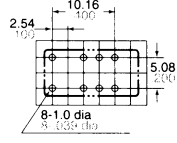

Tolerance: $\pm 0.1 \pm 0.04$

Schematic (Bottom view)

Single side stable
(Deenergized condition)

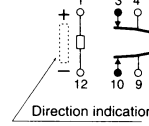

1 coil latching
(Reset condition)

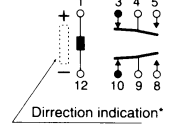

*Orientation stride located on top of relay.

Suggested mounting pad
(Top view)

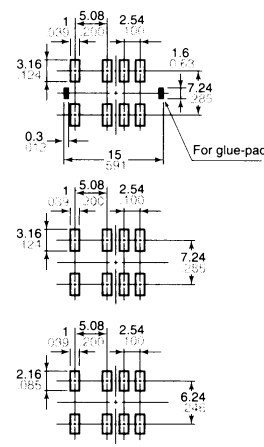

Tolerance: $\pm 0.1 \pm 0.04$

Schematic (Top view)

Single side stable
(Deenergized condition)

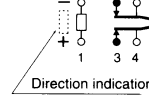

1 coil latching
(Reset condition)

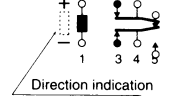

2. coil latching type

Standard PC board terminal

Self clinching terminal

Surface-mount terminal
SA type

SL type

SS type

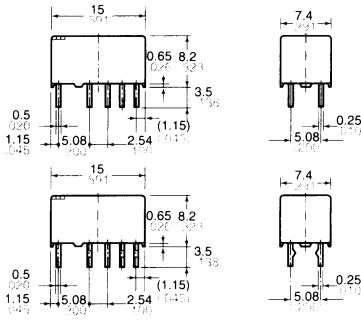

General tolerance: $\pm 0.3 \pm 0.12$

PC board pattern
(Copper side view)

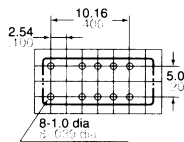

Schematic (Bottom view)

2 coil latching
(Reset condition)

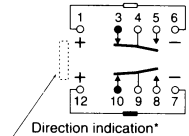

Tolerance: $\pm 0.1 \pm 0.04$

Suggested mounting pad
(Top view)

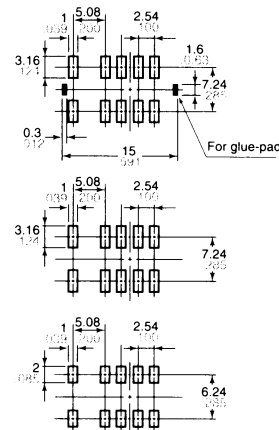

Tolerance: $\pm 0.1 \pm 0.04$

Schematic (Top view)

1 coil latching
(Reset condition)

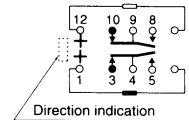

Tolerance: $\pm 0.1 \pm 0.04$

TX DATA

1. Maximum switching capacity

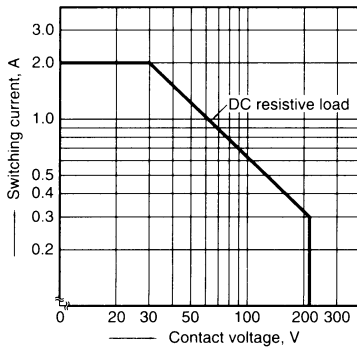

2. Life curve

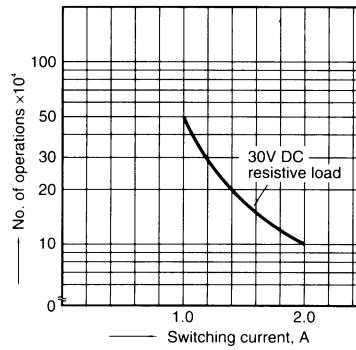

3. Mechanical life

Tested sample: TX2-5V, 10 pcs.
Operating frequency: 180 cpm

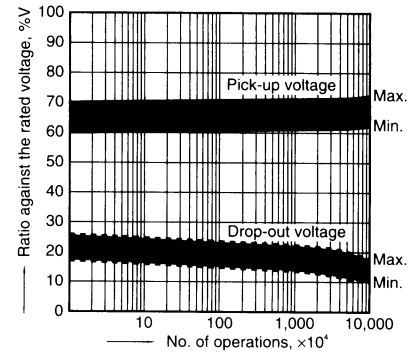

4. Electrical life

Tested sample: TX2-5V, 6 pcs.
Operating frequency: 20 cpm
Change of pick-up and drop-out voltage

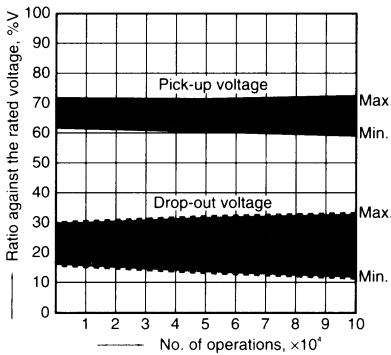

Change of contact resistance

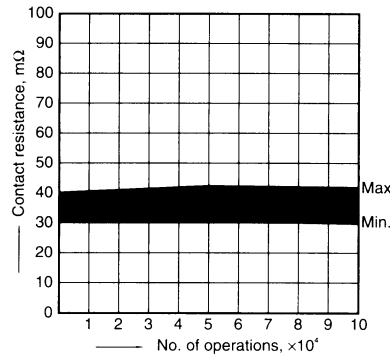

5-(1). Coil temperature rise

Tested sample: TX2-5V, 6 pcs.
Point measured: Inside the coil
Ambient temperature: 25°C 77 F, 85°C 185 F

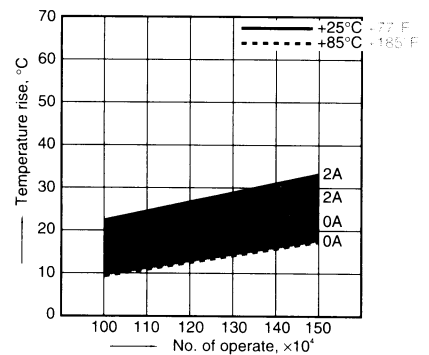

5-(2). Coil temperature rise

Tested sample: TX2-48V, 6 pcs.
Point measured: Inside the coil
Ambient temperature: 25°C 77 F, 70°C 158 F

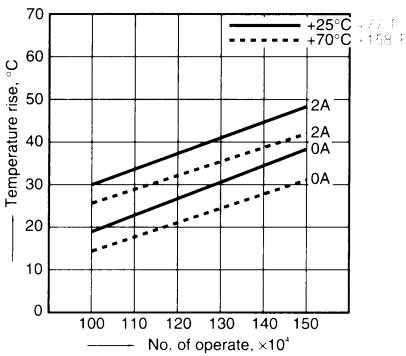

6-(1). Operate and release time (with diode)

Tested sample: TX2-5V, 10 pcs.

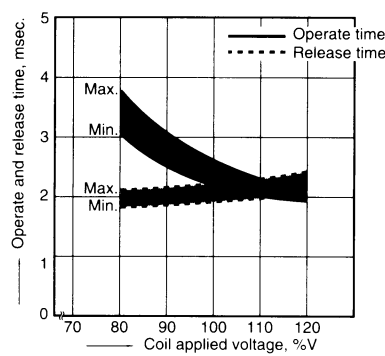

6-(2). Operate and release time (without diode)

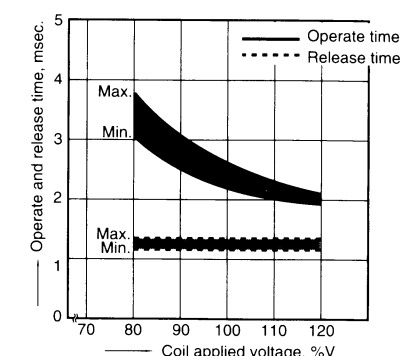

7. Distribution of pick-up and drop-out voltage

Tested sample: TX2-5V, 50 pcs.

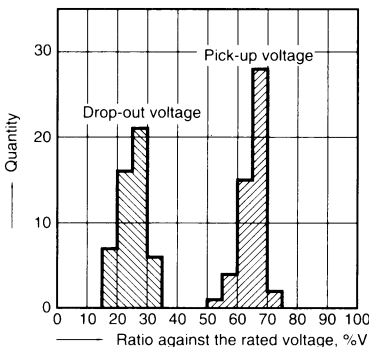

8. Distribution of set and reset voltage

Tested sample: TX2-L2-12V, 30 pcs.

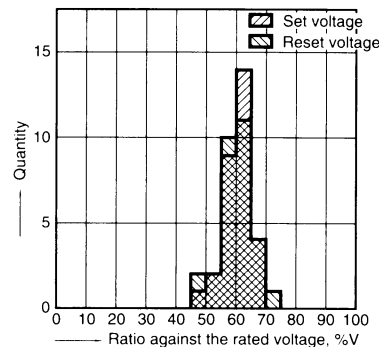

9. Ambient temperature characteristics

Tested sample: TX2-5V, 5 pcs.

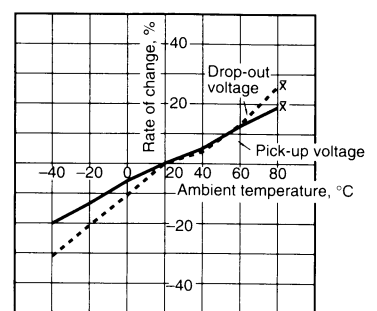

10. Distribution of contact resistance
Tested sample: TX2-5V, 30 pcs. (30x4 contacts)

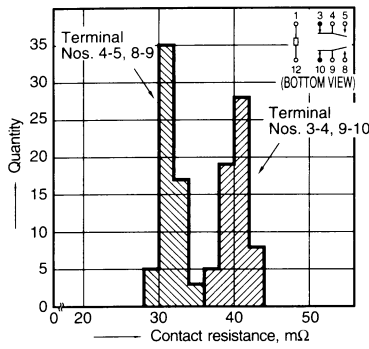

11-(1). High frequency characteristics
Tested sample: TX2-12V, 2 pcs.
Isolation characteristics

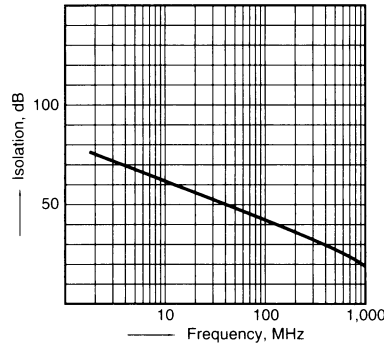

11-(2). High frequency characteristics
Tested sample: TX2-12V, 2 pcs.
Insertion loss characteristics

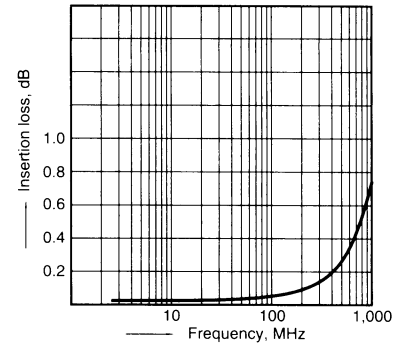

12-(1). Malfunctional shock (single side stable)
Tested sample: TX2-5V, 6 pcs

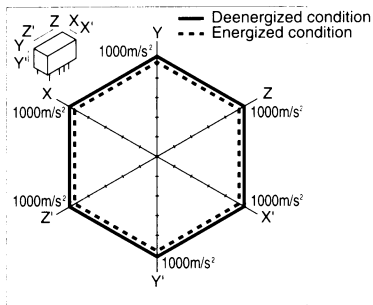

12-(2). Malfunctional shock (latching)
Tested sample: TX2-L2-12V, 6 pcs

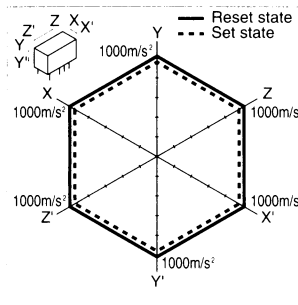

13-(1). Influence of adjacent mounting

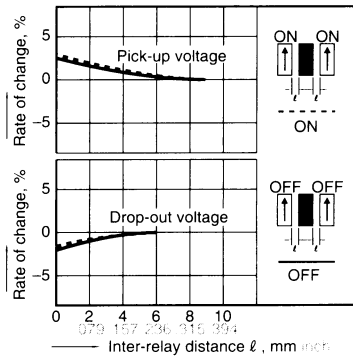

13-(2). Influence of adjacent mounting

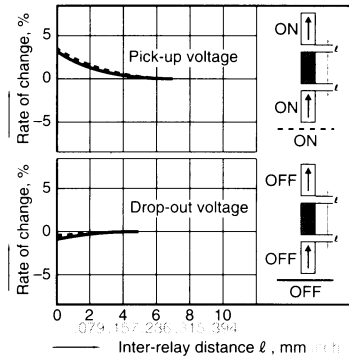

13-(3). Influence of adjacent mounting

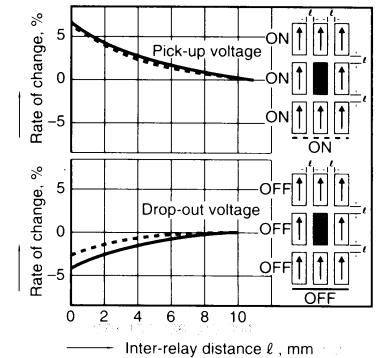

14. Pulse dialing test
Tested sample: TX2-5V, 6 pcs
(35 mA 48V DC wire spring relay load)
Circuit

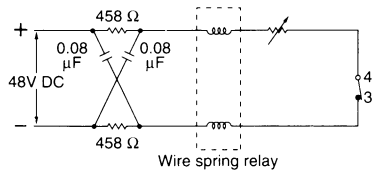

Change of pick-up and drop-out voltage

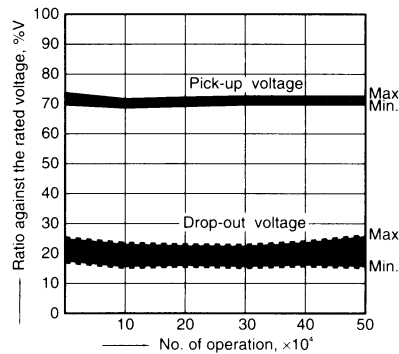

Change of contact resistance

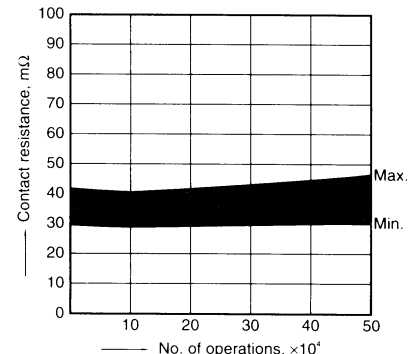

Note: Data of surface-mount type are the same as those of PC board terminal type.

NOTES

1. Coil operating power

Pure DC current should be applied to the coil. The wave form should be rectangular. If it includes ripple, the ripple factor should be less than 5%. However, check it with the actual circuit since the characteristics may be slightly different. The nominal operating voltage should be applied to the coil for more than 10 ms to set/reset the latching type relay.

2. Coil connection

When connecting coils, refer to the wiring diagram to prevent mis-operation or malfunction.

3. External magnetic field

Since T-Series relays are highly sensitive polarized relays, their characteristics will be affected by a strong external magnetic field. Avoid using the relay under that conditions.

4. Usage, transport, and storage conditions

1) Ambient temperature, humidity, and atmospheric pressure during usage, transport, and storage of the relay:

TX(-SMD)

(1) Temperature:

-40 to +85°C -40 to +185°F.

The temperature range is

-40 to +70°C -40 to +158°F for the packaged relay.

(2) Humidity: 5 to 85% R.H.

(Avoid freezing and condensation.)

The humidity range varies with the temperature. Use within the range indicated in the graph below.

(3) Atmospheric pressure: 86 to 106 kPa

Temperature and humidity range for usage, transport, and storage:

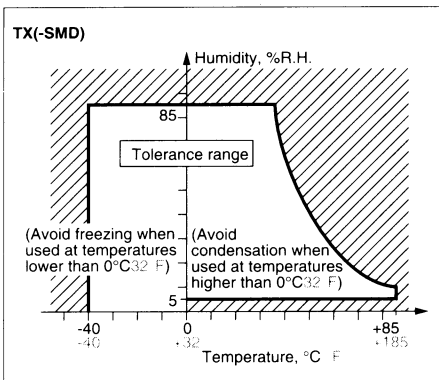

2) Condensation

Condensation forms when there is a sudden change in temperature under high temperature, high humidity conditions. Condensation will cause deterioration of the relay insulation.

3) Freezing

Condensation or other moisture may freeze on the relay when the temperature is lower than 0°C 32°F.

This causes problems such as sticking of movable parts or operational time lags.

4) Low temperature, low humidity environments

The plastic becomes brittle if the relay is exposed to a low temperature, low humidity environment for long periods of time.

5. M.B.B. contact relays

A small OFF time may be generated by the contact bounce during contact switching. Check the actual circuit carefully.

If the relay is dropped accidentally, check the appearance and characteristics including M.B.B. time before use.

6. Packing style

1) Tube orientation for both standard through hole terminal type (including self-clinching type) and surface-mount terminal type.

The relay is packed in a tube with the relay orientation mark on the left side, as shown in the figure below.

Take note of the relay orientation when mounting relays on the printed circuit board.

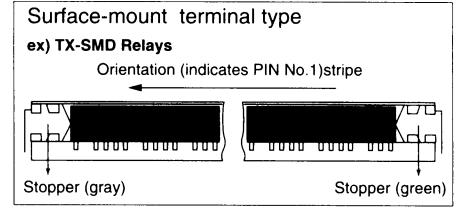
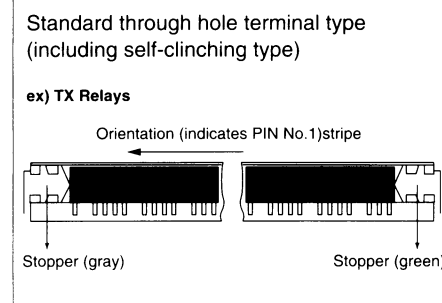

(2) Tape and reel packing (surface-mount terminal type)

(1) Tape dimensions TX-SMD Relays

(i) SA type

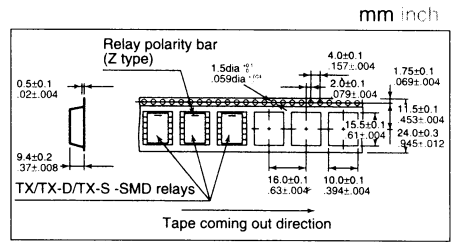

(ii) SL, SS type

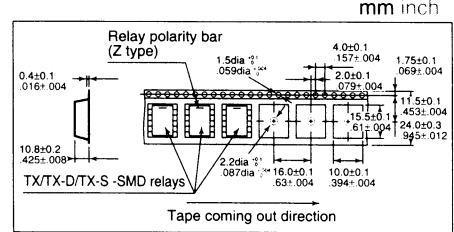

(2) Dimensions of plastic reel TX-SMD Relays

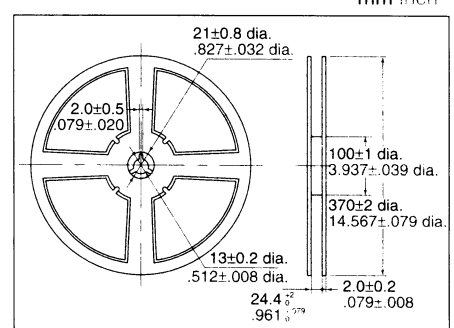

7. Automatic insertion

To maintain the internal function of the relay, the chucking pressure should not exceed the values below.

Chucking pressure in the direction A:
4.9 N {500 g} or less

Chucking pressure in the direction B:
9.8 N {1 kg} or less

Chucking pressure in the direction C:
9.8 N {1 kg} or less

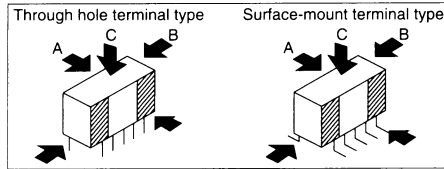

Please chuck the portion.
Avoid chucking the center of the relay.

8. Soldering

1) Preheat according to the following conditions.

Temperature	100°C 212 F or less
Time	Within approx. 1 minute

When soldering standard PC board terminals or self-clinching terminals, soldering should be done at 250°C 482°F within 5 sec.

2) When soldering surface-mount terminals, the following conditions are recommended.

(1) IR (Infrared reflow) soldering method

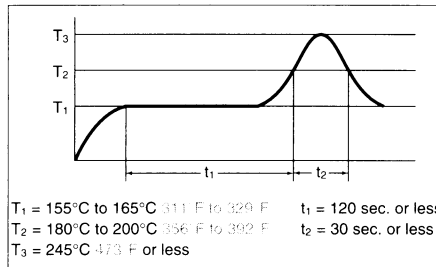

(2) Vapor phase soldering method

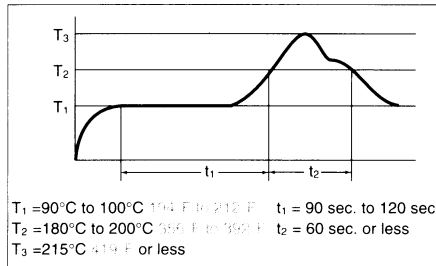

(3) Soldering iron method
Tip temperature: 280°C to 300°C
536°F to 572°C

Wattage: 30 to 60 W

Soldering time: within 5 sec.

(4) Other soldering methods
Check mounting conditions before using other soldering methods (hot-air, hot plate, pulse heater, etc.).

Remarks

- The temperature profile indicates the temperature of the soldered terminal on the surface of the PC board. The ambient temperature may increase excessively. Check the temperature under mounting conditions.
- The conditions for the infrared reflow soldering apply when preheating using the VPS method.

9. Cleaning

In automatic cleaning, cleaning with the boiling method is recommended. Avoid ultrasonic cleaning which subject the relay to high frequency vibrations. It may cause the contacts to stick.

It is recommended that a fluorinated hydrocarbon or other alcoholic solvents be used.

10. Others

1) If in error the relay has been dropped, the appearance and characteristics should be checked before use without fail.

2) The cycle lifetime is defined under the standard test condition specified in the JIS* C 5442-1986 standard (temperature 15 to 35°C 59 to 95°F, humidity 25 to 85%). Check this with the real device as it is affected by coil driving circuit, load type, activation frequency, activation phase, ambient conditions and other factors.

3) For secure operations, the voltage applied to the coil should be nominal voltage. In addition, please note that pick-up and drop-out voltage will vary according to the ambient temperature and operation conditions.

4) Latching relays are shipped from the factory in the reset state. A shock to the relay during shipping or installation may cause it to change to the set state.

Therefore, it is recommended that the relay be used in a circuit which initializes the relay to the required state (set or reset) whenever the power is turned on.

5) Check the ambient conditions when storing or transporting the relays and devices containing the relays. Freezing or condensation may occur in the relay, causing functional damage. Avoid subjecting the relays to heavy loads, or strong vibration and shocks.

*Japanese Industrial Standards