

MDT0096A2IS-SPI	80 x 160	SPI Interface	TFT Module
Specification			
Version: 1		Date: 01/10/2017	
Revision			
1	29/09/2017	First issue	

Display Features			
Display Size	0.96"		
Resolution	80 x 160		
Orientation	Portrait		
Appearance	RGB		
Logic Voltage	2.8V		
Interface	SPI		
Brightness	350 cd/m ²		
Touchscreen	---		
Module Size	13.30 x 27.948 x 1.4mm		
Operating Temperature	-20°C ~ +70°C		
Pinout	13 way FFC		Box Quantity
Pitch	0.7mm		Weight / Display

* - For full design functionality, please use this specification in conjunction with the ST7735S specification.(Provided Separately)

Display Accessories	
Part Number	Description

Optional Variants	
Appearances	Voltage

General Description

This display module is a transmissive type color active matrix TFT(Thin Film Transistor liquid crystal display (LCD that uses amorphous silicon TFT as a switching device. This module is composed of a TFT LCD module, a driver circuit, and a back-light unit.The resolution of a 0.96” contains 80(RGB)X160 dots and can display up to 65k colors.

Module Parameter

Features	Details	Unit
Display Size(Diagonal)	0.96	inch
LCD type	α -Si TFT	-
Display Mode	IPS / Transmissive / Normally Black	-
Resolution	80RGB x 160	-
View Direction	All	Best image
Module Outline	13.3(H) ×27.948(V)×1.4(T) (Note 1)	mm
TP Outline	N/A	mm
TP Viewing Area	N/A	mm
TP Active Area	N/A	mm
Active Area	10.80 (H)×21.70(V)	mm
Viewing Area	N/A	mm
Display Colors	65K	-
Interface	4-SPI	-
Driver IC	ST7735S	-
Operating Temperature	-20~70	°C
Storage Temperature	-30~80	°C
Weight	TBD	g

Note 1: Excluding hooks, posts , FPC/FPC tail etc.

Mechanical Drawings

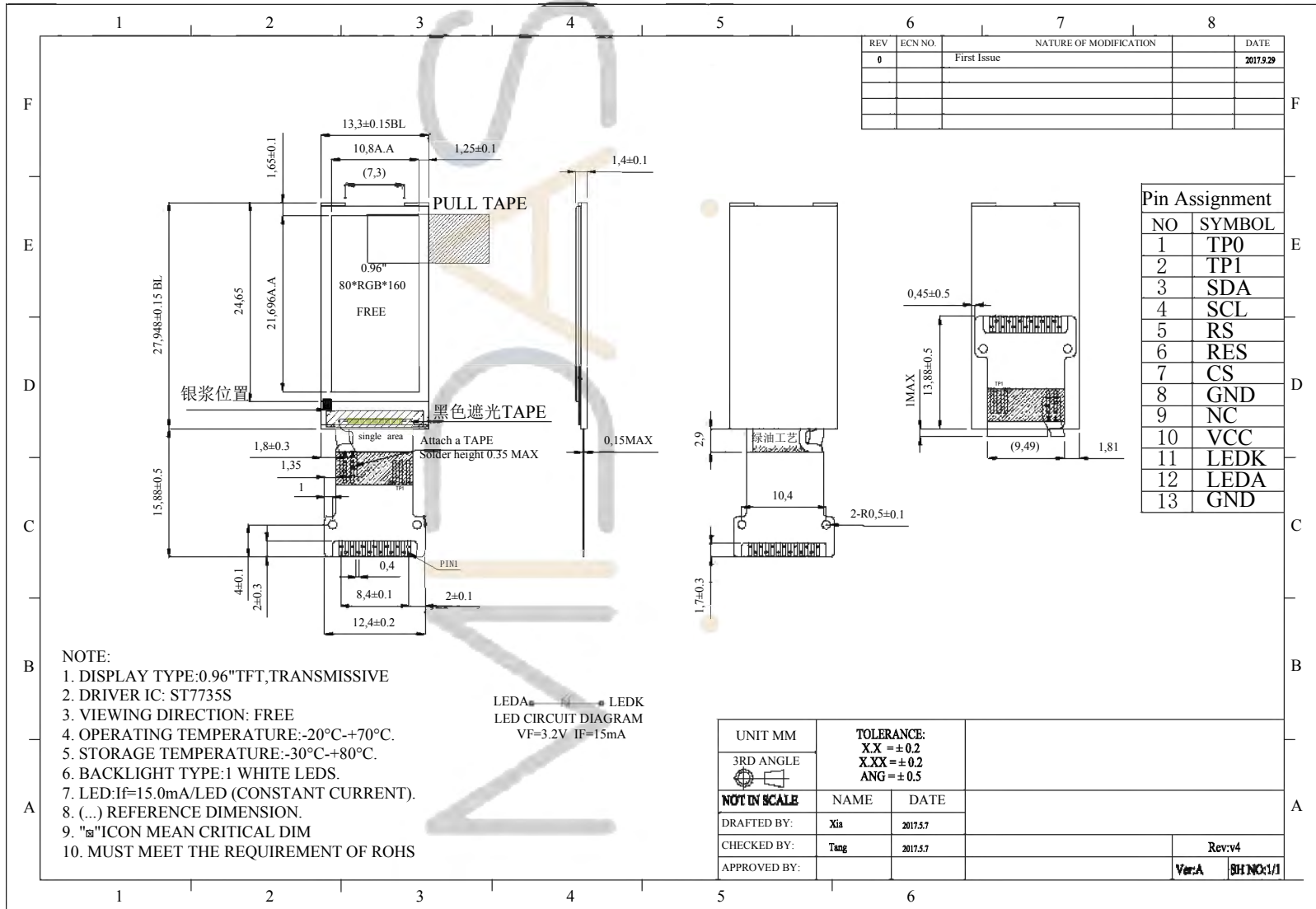

Module Interface

NO	SYMBOL	FUNCTION
1	TP0	Touch Pin, If not used, please open this pin.
2	TP1	Touch Pin ,If not used, please open this pin.
3	SDA	SPI interface input/output pin. The data is latched on the rising edge of the SCL signal.
4	SCL	This pin is used to be serial interface clock.
5	D/C	Display data/command selection pin in 4-line serial interface.
6	RESET	This signal will reset the device and it must be applied to properly initialize the chip. Signal is active low.
7	CS	Chip selection pin; Low enable, High disable.
8	GND	Power Ground
9	NC	No Connect
10	VDD	Power Supply for Analog, VDD=2.5V~3.3V.
11	LEDK	LED Cathode
12	LEDA	LED Anode
13	GND	Power Ground

Module Interface

NO	SYMBOL	FUNCTION
1	TP0	Touch Pin, If not used, please open this pin.
2	TP1	Touch Pin ,If not used, please open this pin.
3	SDA	SPI interface input/output pin. The data is latched on the rising edge of the SCL signal.
4	SCL	This pin is used to be serial interface clock.
5	D/C	Display data/command selection pin in 4-line serial interface.
6	RESET	This signal will reset the device and it must be applied to properly initialize the chip. Signal is active low.
7	CS	Chip selection pin; Low enable, High disable.
8	GND	Power Ground
9	NC	No Connect
10	VDD	Power Supply for Analog, VDD=2.5V~3.3V.
11	LEDK	LED Cathode
12	LEDA	LED Anode
13	GND	Power Ground

Application Circuit

4-Line SPI Interface

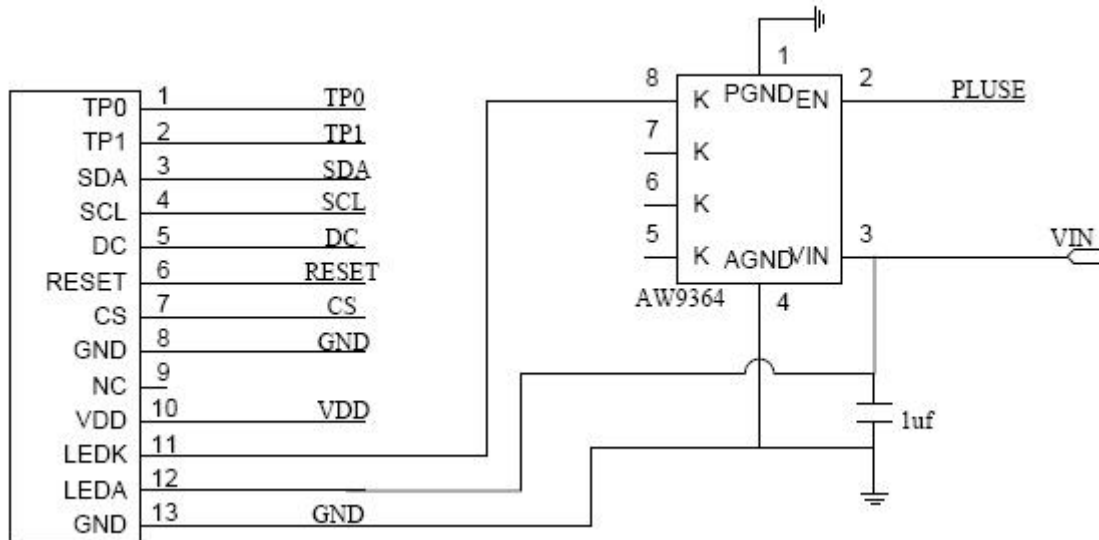



Note1: $V_{IN}=2.8V\sim 5.5V$.

Note2: EN pin signal control AW9364 working condition. When the EN pin signal is converted to high power, and the chip begins to work normally make it. AW9364 built-in shutdown delay circuit when EN pins letter switch from high level to low power and low level The delay of the shutdown of the chip is less than that of the die adjust the effect of LED output current size. When EN pins low electricity maintain time of more than 2ms, chip into shutdown mode.

Backlight recommended circuit

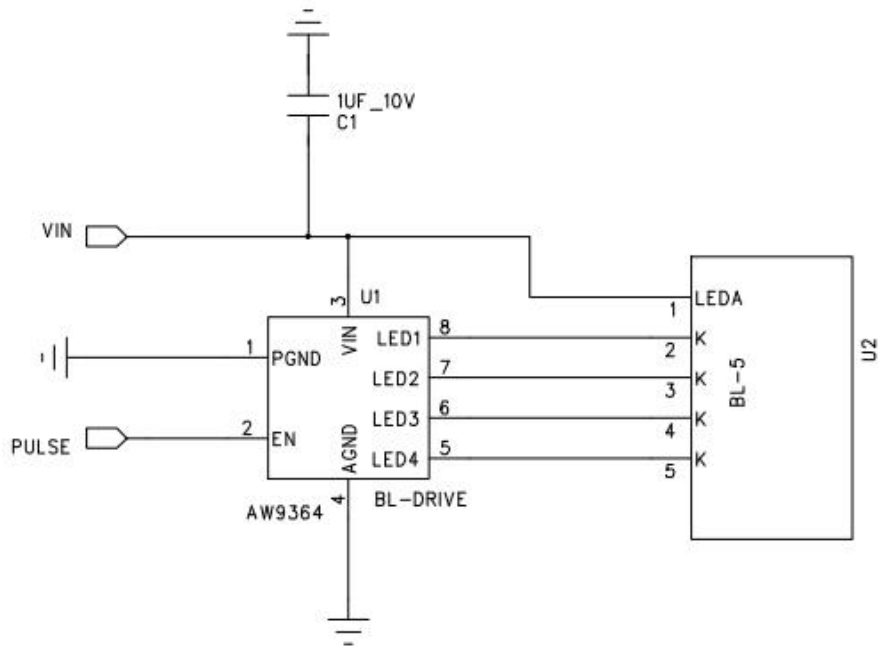
Motherboard driver backlight is need constant current circuit, if the rated voltage screen after light brightness difference. Current and power consumption of the machine are inconsistent, so recommend a backlight driving circuit is best rated current. It is recommended to use IC (AW9364). The reference circuit is as follows:



A(+)  K1(-)

Note: constant current circuit for every LED, and though LED lamp current is less than 20mA. Recommend between 15mA and 20 mA for every LED.

Absolute Maximum Ratings

VSS=0V, Ta=25°C

Item		Symbol	Min.	Max.	Unit
Supply Voltage	Power supply	VDD	-0.3	+4.6	V
	Analog	-	-	-	V
	IO	IOVDD	-0.3	+4.6	V
Input Voltage		V_i	-0.3	IOVDD+0.3	V
Storage temperature		T_{stg}	-30	+80	°C
Operating temperature		T_{op}	-20	+70	°C
Storage humidity		H_{stg}	10	Note 1	%RH
Operating humidity		H_{op}	10	Note 1	%RH

Note 1: 90%RH max, If Ta is below 50°C; 60%RH max, If Ta is over 60°C.

Electrical Specification

DC Characteristics

Item		Symbol	Min.	Typ.	Max.	Unit
Supply Voltage	Power supply	VDD	2.4	2.8	3.3	V
	Analog	VCI	2.4	2.8	3.3	V
	IO	IOVDD	1.65	1.8/2.8	3.3	V
Logic Low input voltage		V_{IL}	-0.3IOVDD	-	0.3IOVDD	V
Logic High input voltage		V_{IH}	0.7IOVDD	-	IOVDD	V
Logic Low output voltage		V_{OL}	-	-	0.2IOVDD	V
Logic High output voltage		V_{OH}	0.8IOVDD	-	-	V
Current Consumption	Normal display	Ivdd	-	15	-	mA
	Standby mode	Ivdd	-	9	-	uA
Frame Frequency		f_{FR}	-	60	-	Hz

AC Characteristics

Reset timing and interface timing:

Please refer to IC datasheet.

Command Table

Please refer to IC datasheet.

Recommended Setting and Initialization Flow for Reference

Please refer to attached file.

Optical Specifications

1. Optical Specifications

Ta=25°C, VDD=2.8V, TN LC+ Polarizer

	Item		Symbol	Condition	Specification			Unit
					Min.	Typ.	Max.	
Backlight On (Transmissive Mode)	Luminance on surface($I_f=15\text{mA}$)		L_V	Normally viewing angle $\theta_x = \theta_y = 0^\circ$	300	350	-	cd/m ²
	Contrast ratio		CR		-	600	-	-
	Response time		T_R		-	10	20	ms
			T_F	-	20	30		
	Chromaticity Transmissive	Red	X_R	-	0.614	0.644	0.674	-
			Y_R		0.290	0.320	0.350	-
		Green	X_G		0.270	0.300	0.330	-
			Y_G		0.540	0.570	0.600	-
		Blue	X_B		0.104	0.134	0.164	-
			Y_B		0.097	0.127	0.157	-
	White	X_W	0.267	0.297	0.327	-		
		Y_W	0.302	0.332	0.362	-		
	Viewing Angle	Horizontal	θ_{x+}	Center $CR \geq 10$	-	80	-	Deg.
			θ_{x-}		-	80	-	
		Vertical	θ_{y+}		-	80	-	
θ_{y-}			-		80	-		
NTSC Ratio(Gamut)		-	-	-	60	-	%	

2. Definition of Response Time

2.1 Normally Black Type (Negative)

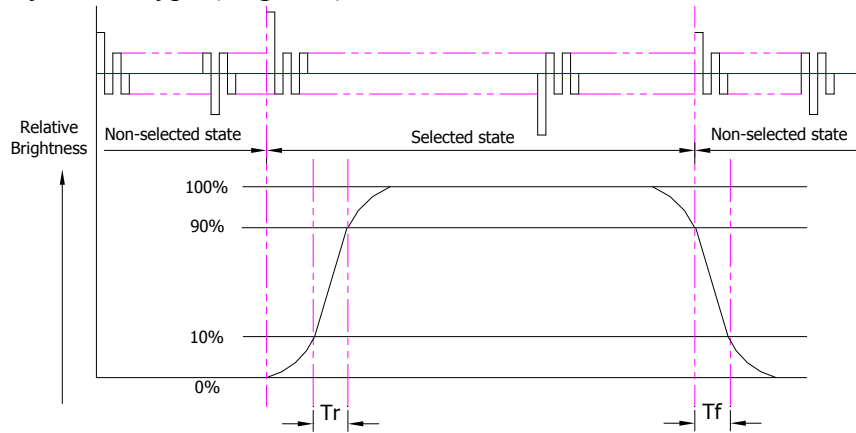

Tr is the time it takes to change from non-selected state with relative luminance 10% to selected state with relative luminance 90%;

Tf is the time it takes to change from selected state with relative luminance 90% to non-selected state with relative luminance 10%.

2.2 Normally White Type (Positive)

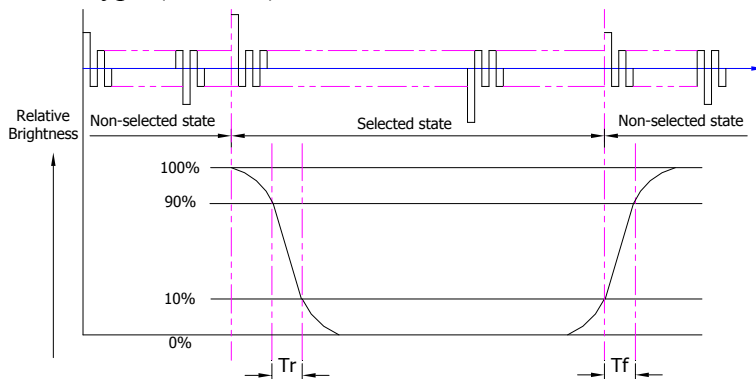

Tr is the time it takes to change from non-selected state with relative luminance 90% to selected state with relative luminance 10%;

Tf is the time it takes to change from selected state with relative luminance 10% to non-selected state with relative luminance 90%;

3. Definition of Contrast Ratio

Contrast is measured perpendicular to display surface in reflective and transmissive mode. The measurement condition is:

Measuring Equipment	BM-7 or EQUI
Measuring Point Diameter	3mm//1mm
Measuring Point Location	Active Area centre point
Test pattern	A: All Pixels white
	B: All Pixel black
Contrast setting	Maximum

Definitions: CR (Contrast) = Luminance of White Pixel / Luminance of Black Pixel

4. Definition of Viewing Angles

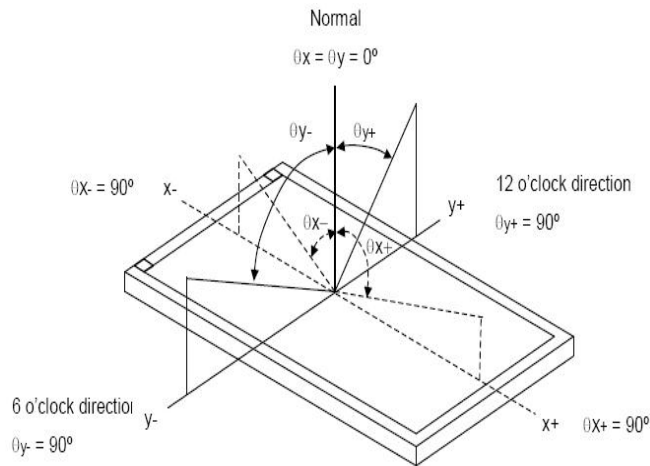

Measuring machine: LCD-5100 or EQUI

5. Definition of Color Appearance

R,G,B and W are defined by (x, y) on the IE chromaticity diagram

NTSC = area of RGB triangle / area of NTSC triangle $\times 100\%$

Measuring picture: Red, Green, Blue and White (Measuring machine: BM-7)

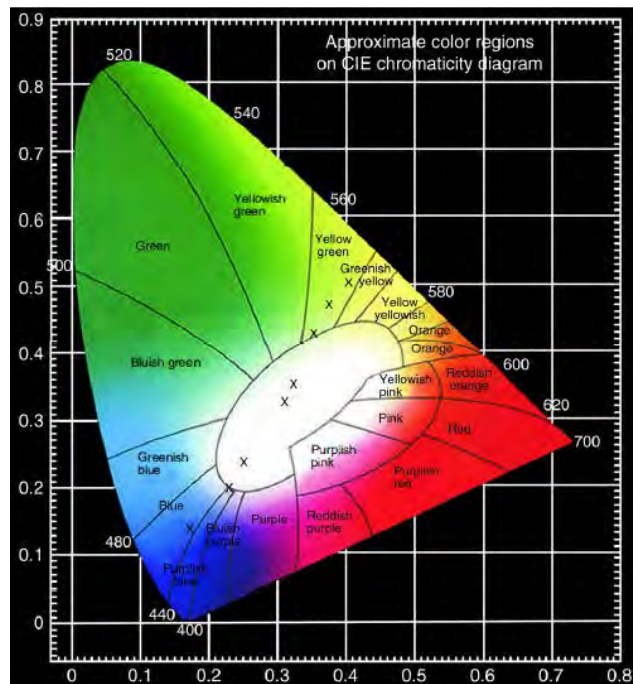

6. Definition of Surface Luminance, Uniformity and Transmittance

Using the transmissive mode measurement approach, measure the white screen luminance of the display panel and backlight.

6.1 Surface Luminance: $LV = \text{average} (LP1:LP9)$

6.2 Uniformity = $\text{Minimal} (LP1:LP9) / \text{Maximal} (LP1:LP9) * 100\%$

6.3 Transmittance = $LV \text{ on LCD} / LV \text{ on Backlight} * 100\%$

Note :Measuring machine:BM-7

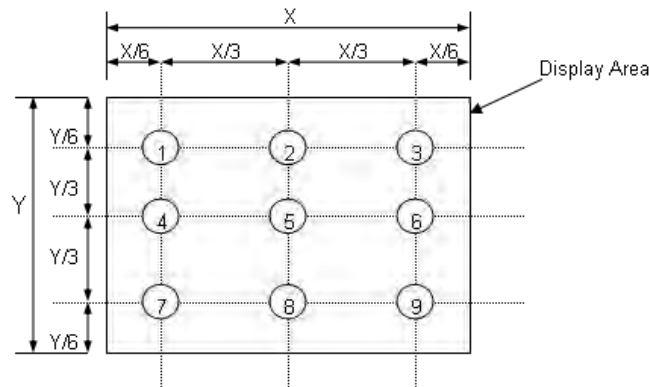

Quality Assurance

1. Purpose

This standard for Quality Assurance assures the quality of LCD module products supplied to customer by Midas display.

2. Agreement Items

Midas and customer shall negotiate if the following situation occurs:

- 2.1 Additional requirement to be added in product specification.
- 2.3 Any other special problem.

3. Standard of the Product Visual Inspection

3.1 Appearance inspection:

3.1.1 The inspection must be under illumination about 1000 – 1500 lx, and the distance of view must be at $30\text{cm} \pm 2\text{cm}$.

3.1.2 The viewing angle should be 45° from the vertical line without reflection light or follows customer's viewing angle specifications.

3.1.3 Definition of area: A Zone: Active Area, B Zone: Viewing Area.

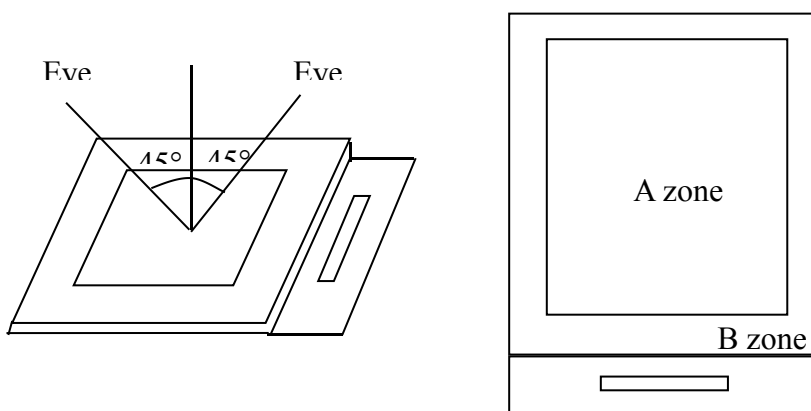

3.2 Basic principle: A set of sample to indicate the limit of acceptable quality level must be discussed by both Midas and customer when there is any dispute happened.

4. Inspection Specification

Sampling plan according to GB/T2828.1-2012/ISO 2859-1: 1999 and ANSI/ASQC

Z1.4-1993,normal level 2 and based on:

Major defect: AQL 0.65

Minor defect: AQL 1.5

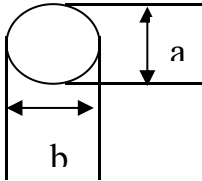
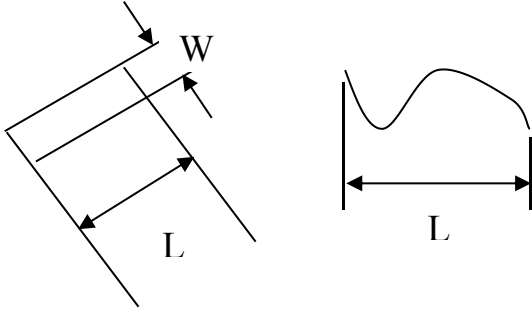
No.	Item	Criteria (Unit: mm)															
01	Black / White spot Foreign material (Round type) Pinholes Stain Particles inside cell. (Minor defect)	 <table border="1" data-bbox="932 663 1433 1055"> <thead> <tr> <th>Size \ Area</th> <th>Acc. Qty</th> </tr> </thead> <tbody> <tr> <td>$\varphi \leq 0.10$</td> <td>Ignore</td> </tr> <tr> <td>$0.10 < \varphi \leq 0.15$</td> <td>2</td> </tr> <tr> <td>$0.15 < \varphi \leq 0.20$</td> <td>1</td> </tr> <tr> <td>$0.20 < \varphi$</td> <td>0</td> </tr> <tr> <td>Total</td> <td>2 no include $\varphi \leq 0.10$</td> </tr> </tbody> </table> <p>$\varphi = (a + b) / 2$</p> <p>Distance between 2 defects should more than 5mm apart.</p>	Size \ Area	Acc. Qty	$\varphi \leq 0.10$	Ignore	$0.10 < \varphi \leq 0.15$	2	$0.15 < \varphi \leq 0.20$	1	$0.20 < \varphi$	0	Total	2 no include $\varphi \leq 0.10$			
Size \ Area	Acc. Qty																
$\varphi \leq 0.10$	Ignore																
$0.10 < \varphi \leq 0.15$	2																
$0.15 < \varphi \leq 0.20$	1																
$0.20 < \varphi$	0																
Total	2 no include $\varphi \leq 0.10$																
02	Black and White line Scratch Foreign material (Line type) (Minor defect)	 <table border="1" data-bbox="643 1541 1267 1827"> <thead> <tr> <th>Length</th> <th>Width</th> <th>Acc. Qty</th> </tr> </thead> <tbody> <tr> <td>/</td> <td>$W \leq 0.03$</td> <td>Ignore</td> </tr> <tr> <td>$L \leq 2$</td> <td>$0.03 < W \leq 0.05$</td> <td>1</td> </tr> <tr> <td>/</td> <td>$0.05 < W$</td> <td>0</td> </tr> <tr> <td colspan="2">Total</td> <td>1</td> </tr> </tbody> </table> <p>Distance between 2 defects should more than 3mm apart. Scratches not viewable through the back of the display are acceptable.</p>	Length	Width	Acc. Qty	/	$W \leq 0.03$	Ignore	$L \leq 2$	$0.03 < W \leq 0.05$	1	/	$0.05 < W$	0	Total		1
Length	Width	Acc. Qty															
/	$W \leq 0.03$	Ignore															
$L \leq 2$	$0.03 < W \leq 0.05$	1															
/	$0.05 < W$	0															
Total		1															

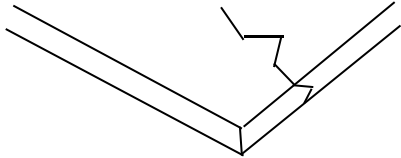
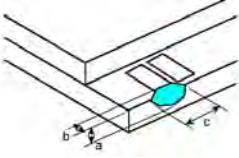
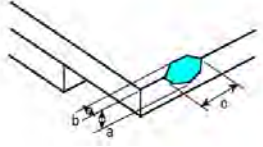
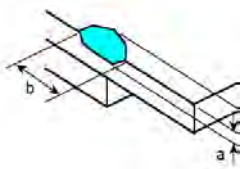
No.	Item	Criteria (Unit: mm)										
03	Glass Crack (Minor defect)	 <p>LCD with extensible crack line is unacceptable(When press the cracked LCD area, the line will expand, we define it is extensible crack line)</p>										
04	Glass Chipping Pad Area: (Minor defect)	 <table border="1" data-bbox="774 817 1244 918"> <thead> <tr> <th>Length and Width</th> <th>Acc. Qty</th> </tr> </thead> <tbody> <tr> <td>$c < 5.0, b < 0.4$</td> <td>Ignore</td> </tr> </tbody> </table>	Length and Width	Acc. Qty	$c < 5.0, b < 0.4$	Ignore						
Length and Width	Acc. Qty											
$c < 5.0, b < 0.4$	Ignore											
05	Glass Chipping Rear of Pad Area: (Minor defect)	 <table border="1" data-bbox="774 1131 1244 1377"> <thead> <tr> <th>Length and Width</th> <th>Acc. Qty</th> </tr> </thead> <tbody> <tr> <td>$c > 3.0, b < 1.0$</td> <td>1</td> </tr> <tr> <td>$c < 3.0, b < 1.0$</td> <td>2</td> </tr> <tr> <td>$c < 3.0, b < 0.5$</td> <td>4</td> </tr> <tr> <td colspan="2">$a < \text{Glass Thickness}$</td> </tr> </tbody> </table>	Length and Width	Acc. Qty	$c > 3.0, b < 1.0$	1	$c < 3.0, b < 1.0$	2	$c < 3.0, b < 0.5$	4	$a < \text{Glass Thickness}$	
Length and Width	Acc. Qty											
$c > 3.0, b < 1.0$	1											
$c < 3.0, b < 1.0$	2											
$c < 3.0, b < 0.5$	4											
$a < \text{Glass Thickness}$												
06	Glass Chipping Except Pad Area: (Minor defect)	 <table border="1" data-bbox="774 1635 1244 1780"> <thead> <tr> <th>Length and Width</th> <th>Acc. Qty</th> </tr> </thead> <tbody> <tr> <td>$c \leq 0.6, b < 5.0$</td> <td>Ignore</td> </tr> <tr> <td colspan="2">$a < \text{Glass Thickness}$</td> </tr> </tbody> </table>	Length and Width	Acc. Qty	$c \leq 0.6, b < 5.0$	Ignore	$a < \text{Glass Thickness}$					
Length and Width	Acc. Qty											
$c \leq 0.6, b < 5.0$	Ignore											
$a < \text{Glass Thickness}$												

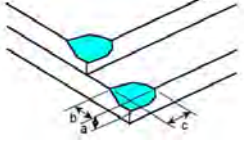
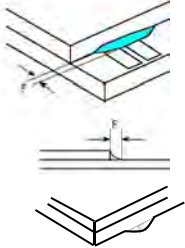
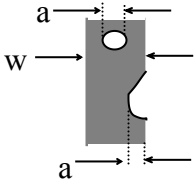
No.	Item	Criteria (Unit: mm)								
07	Glass Corner Chipping: (Minor defect) 	<table border="1" data-bbox="772 389 1241 589"> <thead> <tr> <th>Length and Width</th> <th>Acc. Qty</th> </tr> </thead> <tbody> <tr> <td>$c < 2.0, b < 1.5$</td> <td>Ignore</td> </tr> <tr> <td>$c < 1.5, b < 2$</td> <td>Ignore</td> </tr> <tr> <td colspan="2">$a < \text{Glass Thickness}$</td> </tr> </tbody> </table>	Length and Width	Acc. Qty	$c < 2.0, b < 1.5$	Ignore	$c < 1.5, b < 2$	Ignore	$a < \text{Glass Thickness}$	
Length and Width	Acc. Qty									
$c < 2.0, b < 1.5$	Ignore									
$c < 1.5, b < 2$	Ignore									
$a < \text{Glass Thickness}$										
08	Glass Burr: (Minor defect) 	Glass burr don't affect assemble and module dimension. <table border="1" data-bbox="772 797 1241 898"> <thead> <tr> <th>Length</th> <th>Acc. Qty</th> </tr> </thead> <tbody> <tr> <td>$F < 0.5$</td> <td>Ignore</td> </tr> </tbody> </table>	Length	Acc. Qty	$F < 0.5$	Ignore				
Length	Acc. Qty									
$F < 0.5$	Ignore									
09	FPC Defect: (Minor defect) 	9.1 Dent, pinhole width $a < w/3$. (w: circuitry width.) 9.2 Open circuit is unacceptable. 9.3 No oxidation, contamination and distortion.								
10	Bubble on Polarizer (Minor defect)	<table border="1" data-bbox="772 1375 1241 1574"> <thead> <tr> <th>Diameter</th> <th>Acc. Qty</th> </tr> </thead> <tbody> <tr> <td>$\varphi \leq 0.10$</td> <td>Ignore</td> </tr> <tr> <td>$0.1 < \varphi \leq 0.2$</td> <td>1</td> </tr> <tr> <td>$0.2 < \varphi$</td> <td>None</td> </tr> </tbody> </table>	Diameter	Acc. Qty	$\varphi \leq 0.10$	Ignore	$0.1 < \varphi \leq 0.2$	1	$0.2 < \varphi$	None
Diameter	Acc. Qty									
$\varphi \leq 0.10$	Ignore									
$0.1 < \varphi \leq 0.2$	1									
$0.2 < \varphi$	None									
11	Dent on Polarizer (Minor defect)	<table border="1" data-bbox="772 1603 1241 1803"> <thead> <tr> <th>Diameter</th> <th>Acc. Qty</th> </tr> </thead> <tbody> <tr> <td>$\varphi \leq 0.10$</td> <td>Ignore</td> </tr> <tr> <td>$0.1 < \varphi \leq 0.2$</td> <td>1</td> </tr> <tr> <td>$0.2 < \varphi$</td> <td>None</td> </tr> </tbody> </table>	Diameter	Acc. Qty	$\varphi \leq 0.10$	Ignore	$0.1 < \varphi \leq 0.2$	1	$0.2 < \varphi$	None
Diameter	Acc. Qty									
$\varphi \leq 0.10$	Ignore									
$0.1 < \varphi \leq 0.2$	1									
$0.2 < \varphi$	None									
12	Bezel	12.1 No rust, distortion on the Bezel. 12.2 No visible fingerprints, stains or other contamination.								

No.	Item	Criteria (Unit: mm)
13	Touch Panel	D: Diameter W: width L: length 13.1 Spot: $D \leq 0.20$ is acceptable $0.20 < D \leq 0.3$, acceptable QTY, 3 2dots are acceptable and the distance between defects should more than 10 mm. $D > 0.3$ is unacceptable 13.2 Dent: $D > 0.30$ is unacceptable 13.3 Scratch: $W \leq 0.03$, $L \leq 10$ is acceptable, $0.03 < W \leq 0.10$, $L \leq 10$, acceptable QTY, 3 Distance between 2 defects should more than 10 mm. $W > 0.10$ is unacceptable.
14	PCB	14.1 No distortion or contamination on PCB terminals. 14.2 All components on PCB must same as documented on the BOM/component layout. 14.3 Follow IPC-A-600F.
15	Soldering	Follow IPC-A-610C standard
16	Electrical Defect (Major defect)	The below defects must be rejected. 16.1 Missing vertical / horizontal segment, 16.2 Abnormal Display. 16.3 No function or no display. 16.4 Current exceeds product specifications. 16.5 LCD viewing angle defect. 16.6 No Backlight. 16.7 Dark Backlight. 16.8 Touch Panel no function. 16.9 Dark Dot –one Allowed. 16.10 Bright Dot – one Allowed. Remark: 1. A pixel defect is acceptable if one color is none functional and causes a bright dot. The display may have one case where one color is out and cause a dark dot. 2. Bright dot caused by scratch and foreign object accords to item1.

Remark: Visual and cosmetic defects are rejectable only if these fall within the LCD viewing area.

5. Classification of Defects

Visual defects (Except no / wrong label are treated as minor defect and electrical defect is major.

6. Identification/marketing criteria

Any unit with illegible / wrong /double or no marking/ label shall be rejected.

7. Packing

7.1 There should be no damage of the outside carton box, each packaging box should has label in the correct location per packing drawing requirement.

7.2 All direct package materials shall offer ESD protection.

Reliability Specification

Item	Condition	Cycle Time	Quantity	Remark
Constant Temp. and Constant Humidity Operation Test	+40 ± 3°C, 90 ± 3%RH	120hrs	--	*1
High Temp. Operation Test	+70 ± 3°C	120hrs	--	
Low Temp. Operation Test	-20 ± 3°C	120hrs	--	
Thermal Shock Test	-20 ± 3°C (30min) +70 ± 3°C (30min)	10cycles	--	
ESD Test(end product)	150pF, 330Ω, ±2KV, Contact	10times	--	*2, *3
	150pF, 330Ω, ±6KV, Air			
Vibration Test (for packaging)	Frequency: 10Hz to 55Hz to10Hz, Swing: 1.5mm, time: X, Y, Z each 2H.	6hrs	One inner carton	*4

Note 1. For humidity test, DI water should be used.

Inspection Standard: Inspect after 1-2hrs storage at room temperature, the sample shall be free from the following defects:

- Air bubble in the LCD
- Seal Leakage
- Non-display
- Missing Segment
- Glass Crack
- IDD is greater than twice initial value.
- Others as per QA Inspection Criteria

Note 2. No defect is allowed after testing

The End Product ESD value is only indicative and depends on customer ESD

protection design for the whole system.

Note 3. ESD should be applied to LCD glass panel, not other areas (such as on IC and so on)
IDD should be within twice initial value.

In case of malfunction defect caused by ESD damage, if it would be recovered to normal state after resetting, it would be judged as a good part.

Note 4. Only upon request.

Precautions and Warranty

1. Safety

1.1 The liquid crystal in the LCD is poisonous. Do not put it in your mouth. If the liquid crystal touches your skin or clothes, wash it off immediately using soap and water.

1.2 Since the liquid crystal cells are made of glass, do not apply strong impact on them.

Handle with care.

2. Handling

2.1 Reverse and use within ratings in order to keep performance and prevent damage.

2.2 Do not wipe the polarizer with dry cloth, as it might cause scratch. If the surface of the LCD needs to be cleaned, wipe it swiftly with cotton or other soft cloth soaked with petroleum IPA, do not use other chemicals.

3. Operation

3.1 Do not drive LCD with DC voltage

3.2 Response time will increase below lower temperature

3.3 Display may change color with different temperature

3.4 Mechanical disturbance during operation, such as pressing on the display area, may cause the segments to appear “fractured”.

4. Static Electricity

4.1 CMOS LSIs are equipped in this unit, so care must be taken to avoid the electro-static charge, by ground human body, etc.

4.2 The normal static prevention measures should be observed for work clothes and benches.

4.3 The module should be kept into anti-static bags or other containers resistant to static for storage.

5. Limited Warranty

5.1 Unless otherwise agreed between Midas and customer, Midas will replace or repair any of its LCD and LCM which Midas found to be defective electrically and visually when inspected in accordance with Midas Quality Standards, for a period of one year from date of shipment.

5.2 The warranty liability of Midas is limited to repair and/or replacement. Midas will not be responsible for any consequential loss.

5.3 If possible, we suggest you use up all modules in six months. If the module storage time over twelve months, we suggest that recheck it before the module be used.

Prior Consult Matter

1. For Midas standard products, we keep the right to change material, process for improving the product property without prior notice to our customer.

2. For OEM products, if any changes are needed which may affect the product property, we will consult with our customer in advance.

3. If you have special requirement about reliability condition, please let us know before you start the test on our samples.

Application Circuit

4-Line SPI Interface

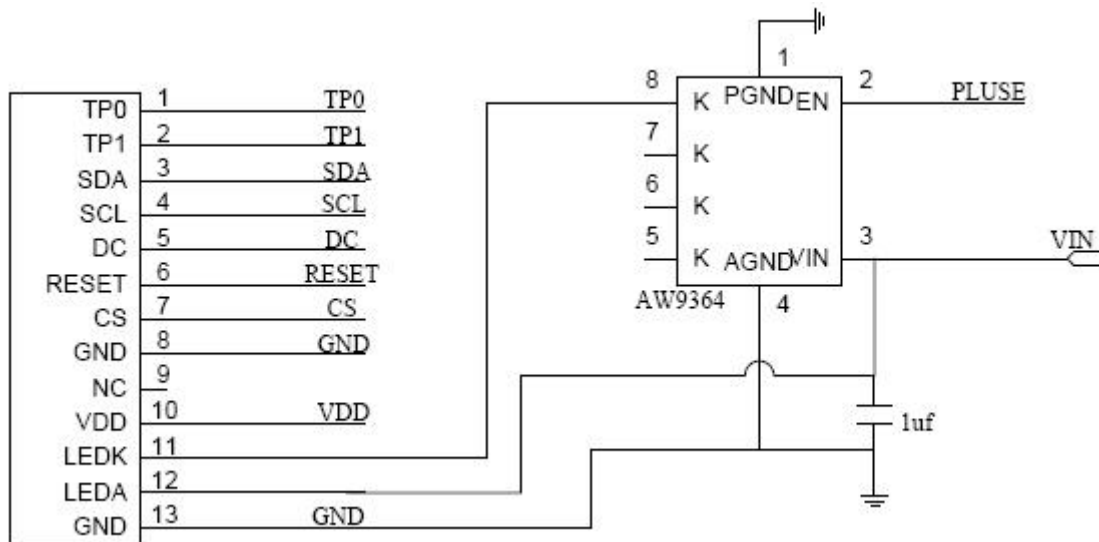



Note1: $V_{IN}=2.8V\sim 5.5V$.

Note2: EN pin signal control AW9364 working condition. When the EN pin signal is converted to high power, and the chip begins to work normally make it. AW9364 built-in shutdown delay circuit when EN pins letter switch from high level to low power and low level The delay of the shutdown of the chip is less than that of the die adjust the effect of LED output current size. When EN pins low electricity maintain time of more than 2ms, chip into shutdown mode.

Backlight recommended circuit

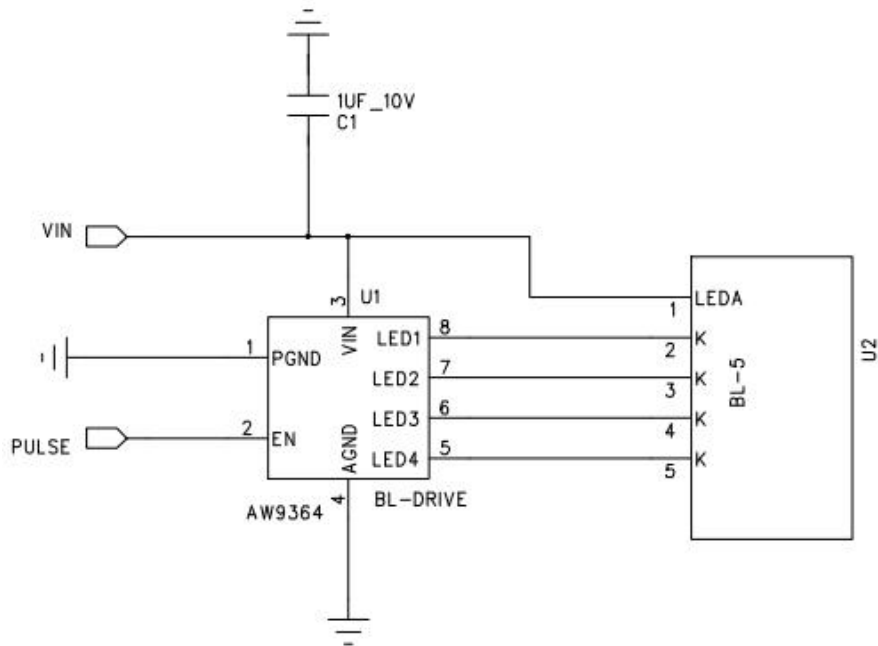
Motherboard driver backlight is need constant current circuit, if the rated voltage screen after light brightness difference. Current and power consumption of the machine are inconsistent, so recommend a backlight driving circuit is best rated current. It is recommended to use IC (AW9364). The reference circuit is as follows:



A(+)  K1(-)

Note: constant current circuit for every LED, and though LED lamp current is less than 20mA. Recommend between 15mA and 20 mA for every LED.

Absolute Maximum Ratings

VSS=0V, Ta=25°C

Item		Symbol	Min.	Max.	Unit
Supply Voltage	Power supply	VDD	-0.3	+4.6	V
	Analog	-	-	-	V
	IO	IOVDD	-0.3	+4.6	V
Input Voltage		V_i	-0.3	IOVDD+0.3	V
Storage temperature		T_{stg}	-30	+80	°C
Operating temperature		T_{op}	-20	+70	°C
Storage humidity		H_{stg}	10	Note 1	%RH
Operating humidity		H_{op}	10	Note 1	%RH

Note 1: 90%RH max, If Ta is below 50°C; 60%RH max, If Ta is over 60°C.

Electrical Specification

DC Characteristics

Item		Symbol	Min.	Typ.	Max.	Unit
Supply Voltage	Power supply	VDD	2.4	2.8	3.3	V
	Analog	VCI	2.4	2.8	3.3	V
	IO	IOVDD	1.65	1.8/2.8	3.3	V
Logic Low input voltage		V_{IL}	-0.3IOVDD	-	0.3IOVDD	V
Logic High input voltage		V_{IH}	0.7IOVDD	-	IOVDD	V
Logic Low output voltage		V_{OL}	-	-	0.2IOVDD	V
Logic High output voltage		V_{OH}	0.8IOVDD	-	-	V
Current Consumption	Normal display	Ivdd	-	15	-	mA
	Standby mode	Ivdd	-	9	-	uA
Frame Frequency		f_{FR}	-	60	-	Hz

AC Characteristics

Reset timing and interface timing:

Please refer to IC datasheet.

Command Table

Please refer to IC datasheet.

Recommended Setting and Initialization Flow for Reference

Please refer to attached file.

Optical Specifications

1. Optical Specifications

Ta=25°C, VDD=2.8V, TN LC+ Polarizer

	Item		Symbol	Condition	Specification			Unit	
					Min.	Typ.	Max.		
Backlight On (Transmissive Mode)	Luminance on surface($I_f=15\text{mA}$)		L_V	Normally viewing angle $\theta_x = \theta_y = 0^\circ$	300	350	-	cd/m ²	
	Contrast ratio		CR		-	600	-	-	
	Response time		T_R		-	10	20	ms	
			T_F	-	20	30			
	Chromaticity Transmissive	Red	X_R	-	0.614	0.644	0.674	-	
			Y_R		0.290	0.320	0.350	-	
		Green	X_G		0.270	0.300	0.330	-	
			Y_G		0.540	0.570	0.600	-	
		Blue	X_B		0.104	0.134	0.164	-	
			Y_B		0.097	0.127	0.157	-	
	White	X_W	0.267		0.297	0.327	-		
		Y_W	0.302		0.332	0.362	-		
	Viewing Angle	Horizontal	θ_{x+}		Center $CR \geq 10$	-	80	-	Deg.
			θ_{x-}			-	80	-	
Vertical		θ_{y+}	-			80	-		
		θ_{y-}	-			80	-		
NTSC Ratio(Gamut)		-	-		-	60	-	%	

2. Definition of Response Time

2.1 Normally Black Type (Negative)

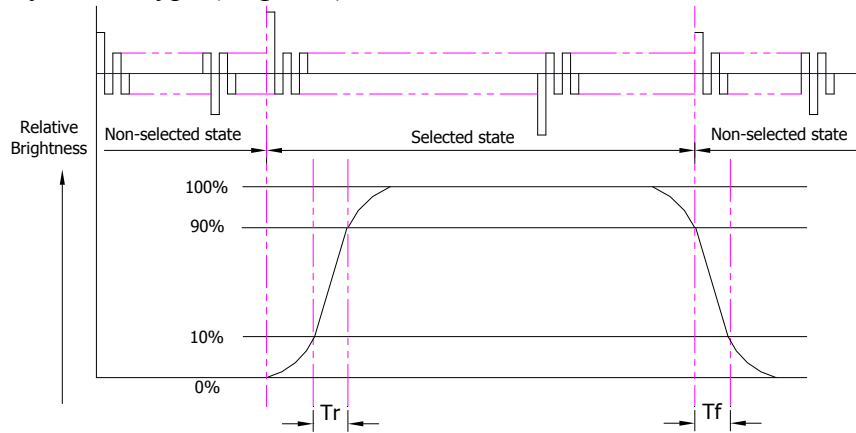

T_r is the time it takes to change from non-selected state with relative luminance 10% to selected state with relative luminance 90%;

T_f is the time it takes to change from selected state with relative luminance 90% to non-selected state with relative luminance 10%.

2.2 Normally White Type (Positive)

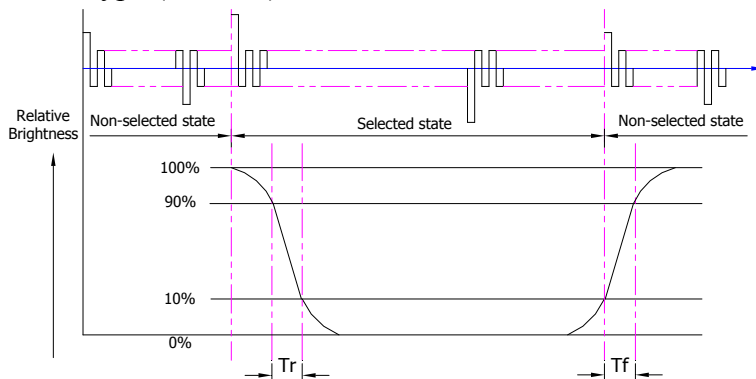

T_r is the time it takes to change from non-selected state with relative luminance 90% to selected state with relative luminance 10%;

T_f is the time it takes to change from selected state with relative luminance 10% to non-selected state with relative luminance 90%;

3. Definition of Contrast Ratio

Contrast is measured perpendicular to display surface in reflective and transmissive mode. The measurement condition is:

Measuring Equipment	BM-7 or EQUI
Measuring Point Diameter	3mm//1mm
Measuring Point Location	Active Area centre point
Test pattern	A: All Pixels white
	B: All Pixel black
Contrast setting	Maximum

Definitions: CR (Contrast) = Luminance of White Pixel / Luminance of Black Pixel

4. Definition of Viewing Angles

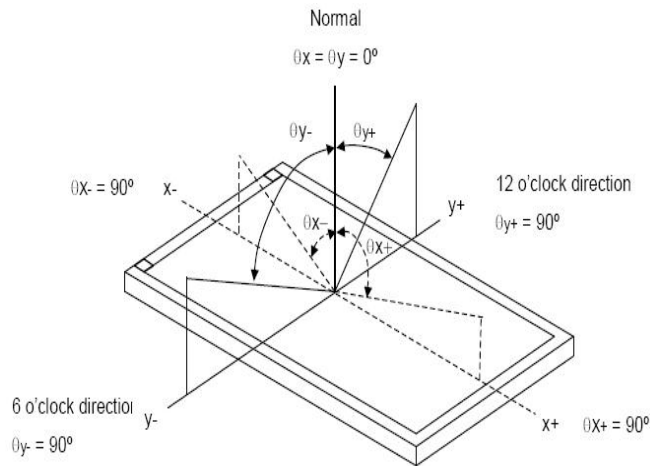

Measuring machine: LCD-5100 or EQUI

5. Definition of Color Appearance

R,G,B and W are defined by (x, y) on the IE chromaticity diagram

NTSC = area of RGB triangle / area of NTSC triangle * 100%

Measuring picture: Red, Green, Blue and White (Measuring machine: BM-7)

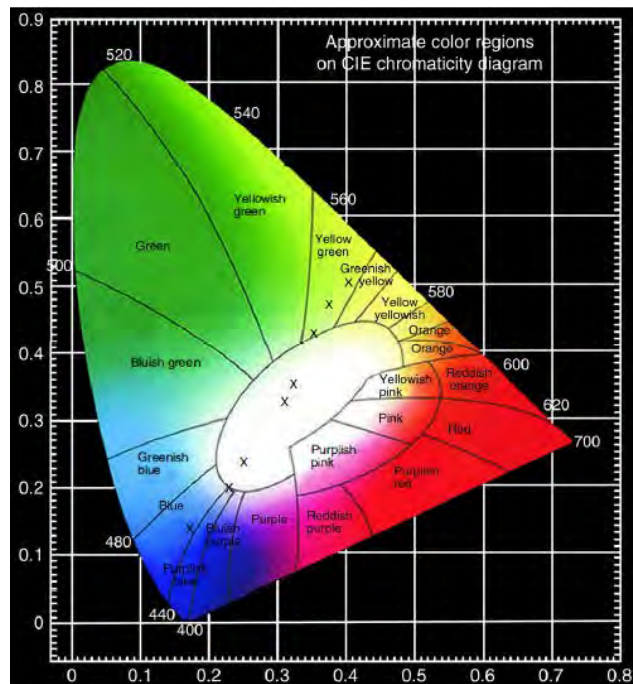

6. Definition of Surface Luminance, Uniformity and Transmittance

Using the transmissive mode measurement approach, measure the white screen luminance of the display panel and backlight.

6.1 Surface Luminance: $LV = \text{average} (LP1:LP9)$

6.2 Uniformity = $\text{Minimal} (LP1:LP9) / \text{Maximal} (LP1:LP9) * 100\%$

6.3 Transmittance = $LV \text{ on LCD} / LV \text{ on Backlight} * 100\%$

Note :Measuring machine:BM-7

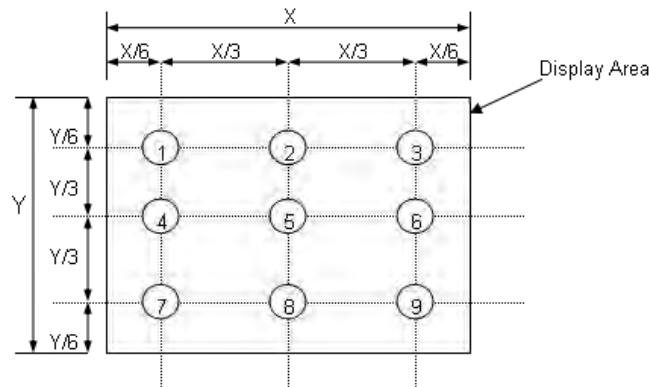

Quality Assurance

1. Purpose

This standard for Quality Assurance assures the quality of LCD module products supplied to customer by Midas display.

2. Agreement Items

Midas and customer shall negotiate if the following situation occurs:

- 2.1 Additional requirement to be added in product specification.
- 2.3 Any other special problem.

3. Standard of the Product Visual Inspection

3.1 Appearance inspection:

3.1.1 The inspection must be under illumination about 1000 – 1500 lx, and the distance of view must be at $30\text{cm} \pm 2\text{cm}$.

3.1.2 The viewing angle should be 45° from the vertical line without reflection light or follows customer's viewing angle specifications.

3.1.3 Definition of area: A Zone: Active Area, B Zone: Viewing Area.

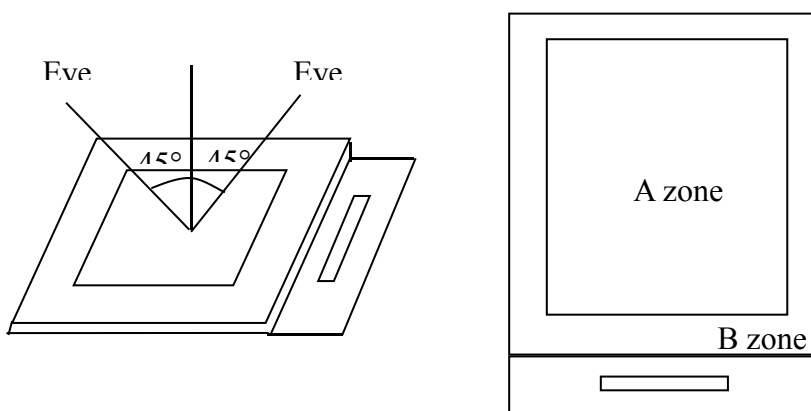

3.2 Basic principle: A set of sample to indicate the limit of acceptable quality level must be discussed by both Midas and customer when there is any dispute happened.

4. Inspection Specification

Sampling plan according to GB/T2828.1-2012/ISO 2859-1: 1999 and ANSI/ASQC

Z1.4-1993,normal level 2 and based on:

Major defect: AQL 0.65

Minor defect: AQL 1.5

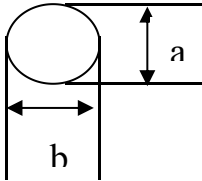
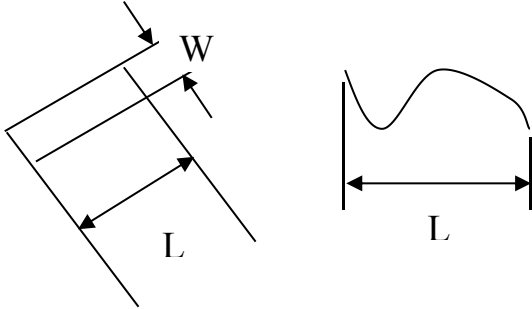
No.	Item	Criteria (Unit: mm)															
01	Black / White spot Foreign material (Round type) Pinholes Stain Particles inside cell. (Minor defect)	 <table border="1" data-bbox="932 663 1433 1055"> <thead> <tr> <th>Size \ Area</th> <th>Acc. Qty</th> </tr> </thead> <tbody> <tr> <td>$\varphi \leq 0.10$</td> <td>Ignore</td> </tr> <tr> <td>$0.10 < \varphi \leq 0.15$</td> <td>2</td> </tr> <tr> <td>$0.15 < \varphi \leq 0.20$</td> <td>1</td> </tr> <tr> <td>$0.20 < \varphi$</td> <td>0</td> </tr> <tr> <td>Total</td> <td>2 no include $\varphi \leq 0.10$</td> </tr> </tbody> </table> <p>$\varphi = (a + b) / 2$</p> <p>Distance between 2 defects should more than 5mm apart.</p>	Size \ Area	Acc. Qty	$\varphi \leq 0.10$	Ignore	$0.10 < \varphi \leq 0.15$	2	$0.15 < \varphi \leq 0.20$	1	$0.20 < \varphi$	0	Total	2 no include $\varphi \leq 0.10$			
Size \ Area	Acc. Qty																
$\varphi \leq 0.10$	Ignore																
$0.10 < \varphi \leq 0.15$	2																
$0.15 < \varphi \leq 0.20$	1																
$0.20 < \varphi$	0																
Total	2 no include $\varphi \leq 0.10$																
02	Black and White line Scratch Foreign material (Line type) (Minor defect)	 <table border="1" data-bbox="643 1541 1268 1825"> <thead> <tr> <th>Length</th> <th>Width</th> <th>Acc. Qty</th> </tr> </thead> <tbody> <tr> <td>/</td> <td>$W \leq 0.03$</td> <td>Ignore</td> </tr> <tr> <td>$L \leq 2$</td> <td>$0.03 < W \leq 0.05$</td> <td>1</td> </tr> <tr> <td>/</td> <td>$0.05 < W$</td> <td>0</td> </tr> <tr> <td colspan="2">Total</td> <td>1</td> </tr> </tbody> </table> <p>Distance between 2 defects should more than 3mm apart. Scratches not viewable through the back of the display are acceptable.</p>	Length	Width	Acc. Qty	/	$W \leq 0.03$	Ignore	$L \leq 2$	$0.03 < W \leq 0.05$	1	/	$0.05 < W$	0	Total		1
Length	Width	Acc. Qty															
/	$W \leq 0.03$	Ignore															
$L \leq 2$	$0.03 < W \leq 0.05$	1															
/	$0.05 < W$	0															
Total		1															

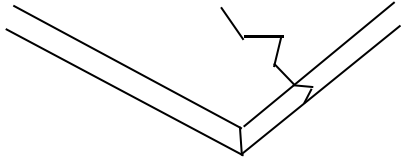
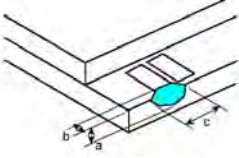
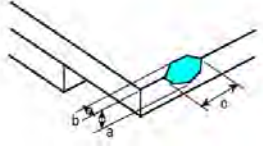
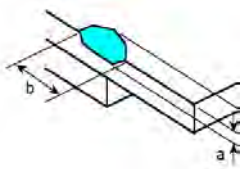
No.	Item	Criteria (Unit: mm)										
03	Glass Crack (Minor defect)	 <p>LCD with extensible crack line is unacceptable(When press the cracked LCD area, the line will expand, we define it is extensible crack line)</p>										
04	Glass Chipping Pad Area: (Minor defect)	 <table border="1" data-bbox="774 817 1244 918"> <thead> <tr> <th>Length and Width</th> <th>Acc. Qty</th> </tr> </thead> <tbody> <tr> <td>$c < 5.0, b < 0.4$</td> <td>Ignore</td> </tr> </tbody> </table>	Length and Width	Acc. Qty	$c < 5.0, b < 0.4$	Ignore						
Length and Width	Acc. Qty											
$c < 5.0, b < 0.4$	Ignore											
05	Glass Chipping Rear of Pad Area: (Minor defect)	 <table border="1" data-bbox="774 1131 1244 1377"> <thead> <tr> <th>Length and Width</th> <th>Acc. Qty</th> </tr> </thead> <tbody> <tr> <td>$c > 3.0, b < 1.0$</td> <td>1</td> </tr> <tr> <td>$c < 3.0, b < 1.0$</td> <td>2</td> </tr> <tr> <td>$c < 3.0, b < 0.5$</td> <td>4</td> </tr> <tr> <td colspan="2">$a < \text{Glass Thickness}$</td> </tr> </tbody> </table>	Length and Width	Acc. Qty	$c > 3.0, b < 1.0$	1	$c < 3.0, b < 1.0$	2	$c < 3.0, b < 0.5$	4	$a < \text{Glass Thickness}$	
Length and Width	Acc. Qty											
$c > 3.0, b < 1.0$	1											
$c < 3.0, b < 1.0$	2											
$c < 3.0, b < 0.5$	4											
$a < \text{Glass Thickness}$												
06	Glass Chipping Except Pad Area: (Minor defect)	 <table border="1" data-bbox="774 1635 1244 1780"> <thead> <tr> <th>Length and Width</th> <th>Acc. Qty</th> </tr> </thead> <tbody> <tr> <td>$c \leq 0.6, b < 5.0$</td> <td>Ignore</td> </tr> <tr> <td colspan="2">$a < \text{Glass Thickness}$</td> </tr> </tbody> </table>	Length and Width	Acc. Qty	$c \leq 0.6, b < 5.0$	Ignore	$a < \text{Glass Thickness}$					
Length and Width	Acc. Qty											
$c \leq 0.6, b < 5.0$	Ignore											
$a < \text{Glass Thickness}$												

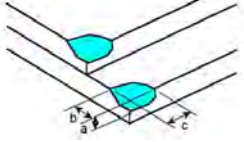
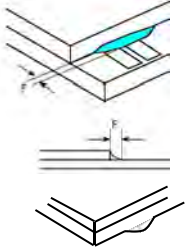
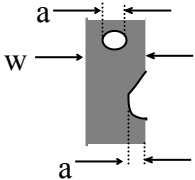
No.	Item	Criteria (Unit: mm)								
07	Glass Corner Chipping: (Minor defect) 	<table border="1" data-bbox="772 389 1241 589"> <thead> <tr> <th>Length and Width</th> <th>Acc. Qty</th> </tr> </thead> <tbody> <tr> <td>$c < 2.0, b < 1.5$</td> <td>Ignore</td> </tr> <tr> <td>$c < 1.5, b < 2$</td> <td>Ignore</td> </tr> <tr> <td colspan="2">$a < \text{Glass Thickness}$</td> </tr> </tbody> </table>	Length and Width	Acc. Qty	$c < 2.0, b < 1.5$	Ignore	$c < 1.5, b < 2$	Ignore	$a < \text{Glass Thickness}$	
Length and Width	Acc. Qty									
$c < 2.0, b < 1.5$	Ignore									
$c < 1.5, b < 2$	Ignore									
$a < \text{Glass Thickness}$										
08	Glass Burr: (Minor defect) 	Glass burr don't affect assemble and module dimension. <table border="1" data-bbox="772 797 1241 898"> <thead> <tr> <th>Length</th> <th>Acc. Qty</th> </tr> </thead> <tbody> <tr> <td>$F < 0.5$</td> <td>Ignore</td> </tr> </tbody> </table>	Length	Acc. Qty	$F < 0.5$	Ignore				
Length	Acc. Qty									
$F < 0.5$	Ignore									
09	FPC Defect: (Minor defect) 	9.1 Dent, pinhole width $a < w/3$. (w: circuitry width.) 9.2 Open circuit is unacceptable. 9.3 No oxidation, contamination and distortion.								
10	Bubble on Polarizer (Minor defect)	<table border="1" data-bbox="772 1375 1241 1574"> <thead> <tr> <th>Diameter</th> <th>Acc. Qty</th> </tr> </thead> <tbody> <tr> <td>$\varphi \leq 0.10$</td> <td>Ignore</td> </tr> <tr> <td>$0.1 < \varphi \leq 0.2$</td> <td>1</td> </tr> <tr> <td>$0.2 < \varphi$</td> <td>None</td> </tr> </tbody> </table>	Diameter	Acc. Qty	$\varphi \leq 0.10$	Ignore	$0.1 < \varphi \leq 0.2$	1	$0.2 < \varphi$	None
Diameter	Acc. Qty									
$\varphi \leq 0.10$	Ignore									
$0.1 < \varphi \leq 0.2$	1									
$0.2 < \varphi$	None									
11	Dent on Polarizer (Minor defect)	<table border="1" data-bbox="772 1603 1241 1803"> <thead> <tr> <th>Diameter</th> <th>Acc. Qty</th> </tr> </thead> <tbody> <tr> <td>$\varphi \leq 0.10$</td> <td>Ignore</td> </tr> <tr> <td>$0.1 < \varphi \leq 0.2$</td> <td>1</td> </tr> <tr> <td>$0.2 < \varphi$</td> <td>None</td> </tr> </tbody> </table>	Diameter	Acc. Qty	$\varphi \leq 0.10$	Ignore	$0.1 < \varphi \leq 0.2$	1	$0.2 < \varphi$	None
Diameter	Acc. Qty									
$\varphi \leq 0.10$	Ignore									
$0.1 < \varphi \leq 0.2$	1									
$0.2 < \varphi$	None									
12	Bezel	12.1 No rust, distortion on the Bezel. 12.2 No visible fingerprints, stains or other contamination.								

No.	Item	Criteria (Unit: mm)
13	Touch Panel	D: Diameter W: width L: length 13.1 Spot: $D \leq 0.20$ is acceptable $0.20 < D \leq 0.3$, acceptable QTY, 3 2dots are acceptable and the distance between defects should more than 10 mm. $D > 0.3$ is unacceptable 13.2 Dent: $D > 0.30$ is unacceptable 13.3 Scratch: $W \leq 0.03$, $L \leq 10$ is acceptable, $0.03 < W \leq 0.10$, $L \leq 10$, acceptable QTY, 3 Distance between 2 defects should more than 10 mm. $W > 0.10$ is unacceptable.
14	PCB	14.1 No distortion or contamination on PCB terminals. 14.2 All components on PCB must same as documented on the BOM/component layout. 14.3 Follow IPC-A-600F.
15	Soldering	Follow IPC-A-610C standard
16	Electrical Defect (Major defect)	The below defects must be rejected. 16.1 Missing vertical / horizontal segment, 16.2 Abnormal Display. 16.3 No function or no display. 16.4 Current exceeds product specifications. 16.5 LCD viewing angle defect. 16.6 No Backlight. 16.7 Dark Backlight. 16.8 Touch Panel no function. 16.9 Dark Dot –one Allowed. 16.10 Bright Dot – one Allowed. Remark: 1. A pixel defect is acceptable if one color is none functional and causes a bright dot. The display may have one case where one color is out and cause a dark dot. 2. Bright dot caused by scratch and foreign object accords to item1.

Remark: Visual and cosmetic defects are rejectable only if these fall within the LCD viewing area.

5. Classification of Defects

Visual defects (Except no / wrong label are treated as minor defect and electrical defect is major.

6. Identification/marketing criteria

Any unit with illegible / wrong /double or no marking/ label shall be rejected.

7. Packing

7.1 There should be no damage of the outside carton box, each packaging box should has label in the correct location per packing drawing requirement.

7.2 All direct package materials shall offer ESD protection.

Reliability Specification

Item	Condition	Cycle Time	Quantity	Remark
Constant Temp. and Constant Humidity Operation Test	+40 ± 3°C, 90 ± 3%RH	120hrs	--	*1
High Temp. Operation Test	+70 ± 3°C	120hrs	--	
Low Temp. Operation Test	-20 ± 3°C	120hrs	--	
Thermal Shock Test	-20 ± 3°C (30min) +70 ± 3°C (30min)	10cycles	--	
ESD Test(end product)	150pF, 330Ω, ±2KV, Contact	10times	--	*2, *3
	150pF, 330Ω, ±6KV, Air			
Vibration Test (for packaging)	Frequency: 10Hz to 55Hz to10Hz, Swing: 1.5mm, time: X, Y, Z each 2H.	6hrs	One inner carton	*4

Note 1. For humidity test, DI water should be used.

Inspection Standard: Inspect after 1-2hrs storage at room temperature, the sample shall be free from the following defects:

- Air bubble in the LCD
- Seal Leakage
- Non-display
- Missing Segment
- Glass Crack
- IDD is greater than twice initial value.
- Others as per QA Inspection Criteria

Note 2. No defect is allowed after testing

The End Product ESD value is only indicative and depends on customer ESD

protection design for the whole system.

Note 3. ESD should be applied to LCD glass panel, not other areas (such as on IC and so on)
IDD should be within twice initial value.

In case of malfunction defect caused by ESD damage, if it would be recovered to normal state after resetting, it would be judged as a good part.

Note 4. Only upon request.

Precautions and Warranty

1. Safety

1.1 The liquid crystal in the LCD is poisonous. Do not put it in your mouth. If the liquid crystal touches your skin or clothes, wash it off immediately using soap and water.

1.2 Since the liquid crystal cells are made of glass, do not apply strong impact on them.

Handle with care.

2. Handling

2.1 Reverse and use within ratings in order to keep performance and prevent damage.

2.2 Do not wipe the polarizer with dry cloth, as it might cause scratch. If the surface of the LCD needs to be cleaned, wipe it swiftly with cotton or other soft cloth soaked with petroleum IPA, do not use other chemicals.

3. Operation

3.1 Do not drive LCD with DC voltage

3.2 Response time will increase below lower temperature

3.3 Display may change color with different temperature

3.4 Mechanical disturbance during operation, such as pressing on the display area, may cause the segments to appear “fractured”.

4. Static Electricity

4.1 CMOS LSIs are equipped in this unit, so care must be taken to avoid the electro-static charge, by ground human body, etc.

4.2 The normal static prevention measures should be observed for work clothes and benches.

4.3 The module should be kept into anti-static bags or other containers resistant to static for storage.

5. Limited Warranty

5.1 Unless otherwise agreed between Midas and customer, Midas will replace or repair any of its LCD and LCM which Midas found to be defective electrically and visually when inspected in accordance with Midas Quality Standards, for a period of one year from date of shipment.

5.2 The warranty liability of Midas is limited to repair and/or replacement. Midas will not be responsible for any consequential loss.

5.3 If possible, we suggest you use up all modules in six months. If the module storage time over twelve months, we suggest that recheck it before the module be used.

Prior Consult Matter

1. For Midas standard products, we keep the right to change material, process for improving the product property without prior notice to our customer.

2. For OEM products, if any changes are needed which may affect the product property, we will consult with our customer in advance.

3. If you have special requirement about reliability condition, please let us know before you start the test on our samples.