

THIS DRAWING IS UNPUBLISHED.

RELEASED FOR PUBLICATION

© COPYRIGHT - By -

ALL RIGHTS RESERVED.

LOC	DIST	REVISIONS			
P	LTR	DESCRIPTION	DATE	DWN	APVD
G	02	F3	REVISED PER ECO-11-004917	11MAR11	RK HMR

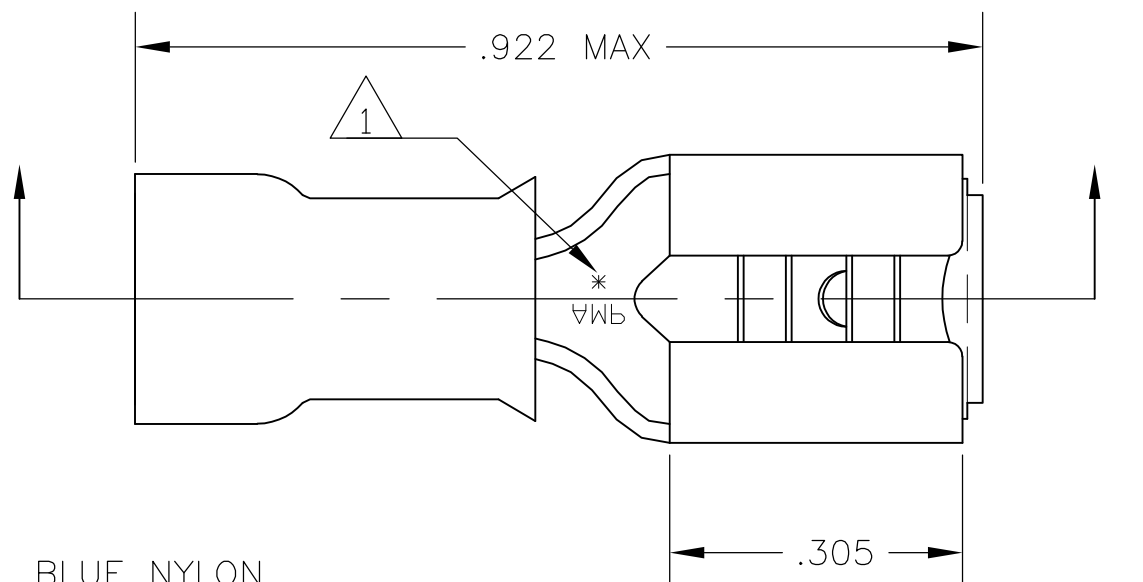

BLUE NYLON INSULATION

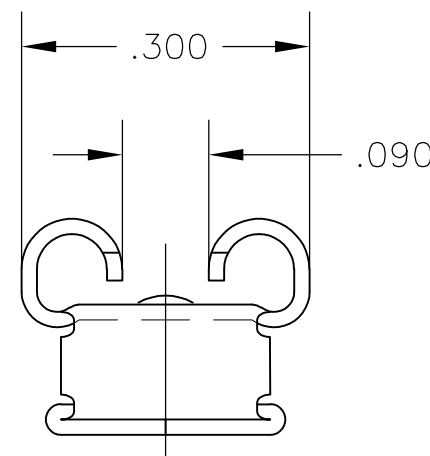
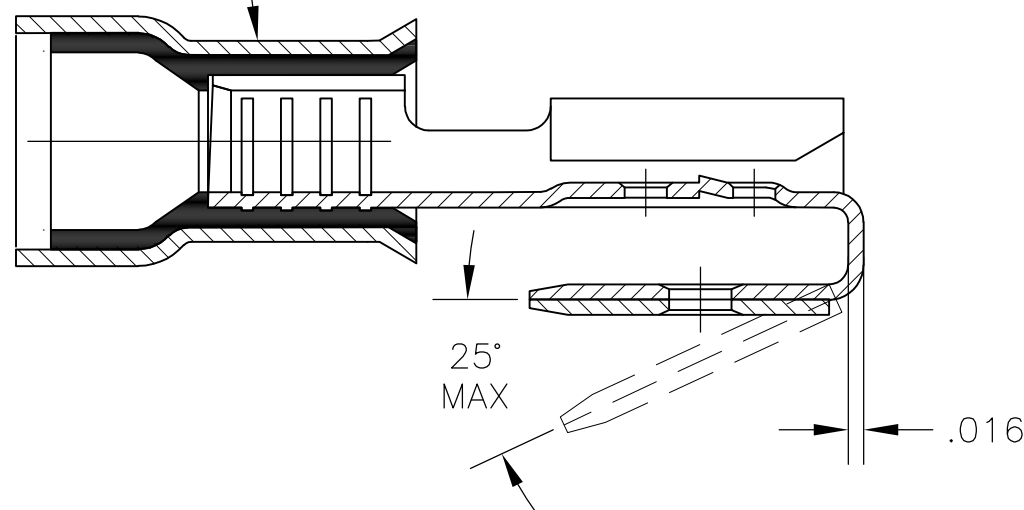

- 1 MATING TAB THICKNESS .032
- 2 ASTERISK * FOR PHOS. BRONZE ITEMS ONLY.
- 3 WIRE INSULATION DIA TO BE .170 MAX.
- 4 MAX RECOMMENDED OPERATING TEMP IS 105°C OR 221°F.
- 5 VOLTAGE RATING IS 300V MAX
- 6 CIRCULAR MIL AREA 1.0-2.5mm² [1973-4934].

PHOS BRONZE ELECTRO-TIN	2	9-160463-5
BRASS ELECTRO-TIN		9-160463-2
DESCRIPTION		PART NO

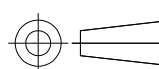
THIS DRAWING IS A CONTROLLED DOCUMENT.		DWN	jr_ruth	11JUL05	 TE Connectivity					
DIMENSIONS: INCHES		CHK	T MICHELUTTI	11JUL05				NAME 250 SERIES P.I.D.G. FASTON REC, ASS'Y, PIGGYBACK WIRE SIZE : 16-14 AWG		
		APVD	T MICHELUTTI	11JUL05						
TOLERANCES UNLESS OTHERWISE SPECIFIED:		MATERIAL						WEIGHT - CUSTOMER DRAWING		
0 PLC ± - 1 PLC ± - 2 PLC ± .02 3 PLC ± .005 4 PLC ± - ANGLES ± 0°30'		FINISH		SCALE 5:1			SHEET 1 OF 1	REV F3		