

GOP Professional

30-28 | 40-30 | 55-36



BOSCH

de Originalbetriebsanleitung

en Original instructions

fr Notice originale

es Manual original

pt Manual original

it Istruzioni originali

nl Oorspronkelijke gebruiksaanwijzing

da Original brugsanvisning

sv Bruksanvisning i original

no Original driftsinstruks

fi Alkuperäiset ohjeet

el Πρωτότυπο οδηγιών χρήσης

tr Orijinal işletme talimatı

pl Instrukcja oryginalna

cs Původní návod k používání

sk Pôvodný návod na použitie

hu Eredeti használati utasítás

ru Оригинальное руководство по эксплуатации

uk Оригінальна інструкція з експлуатації

kk Пайдалану нұсқаулығының түпнұсқасы

ro Instrucțiuni originale

bg Оригинална инструкция

mk Оригинално упатство за работа

sr Originalno uputstvo za rad

sl Izvirna navodila

hr Originalne upute za rad

et Algpärane kasutusjuhend

lv Instrukcijas oriģinālvalodā

lt Originali instrukcija

ko 사용 설명서 원본

ar تعليمات التشغيل الأصلية

fa دفترچه راهنمای اصلی



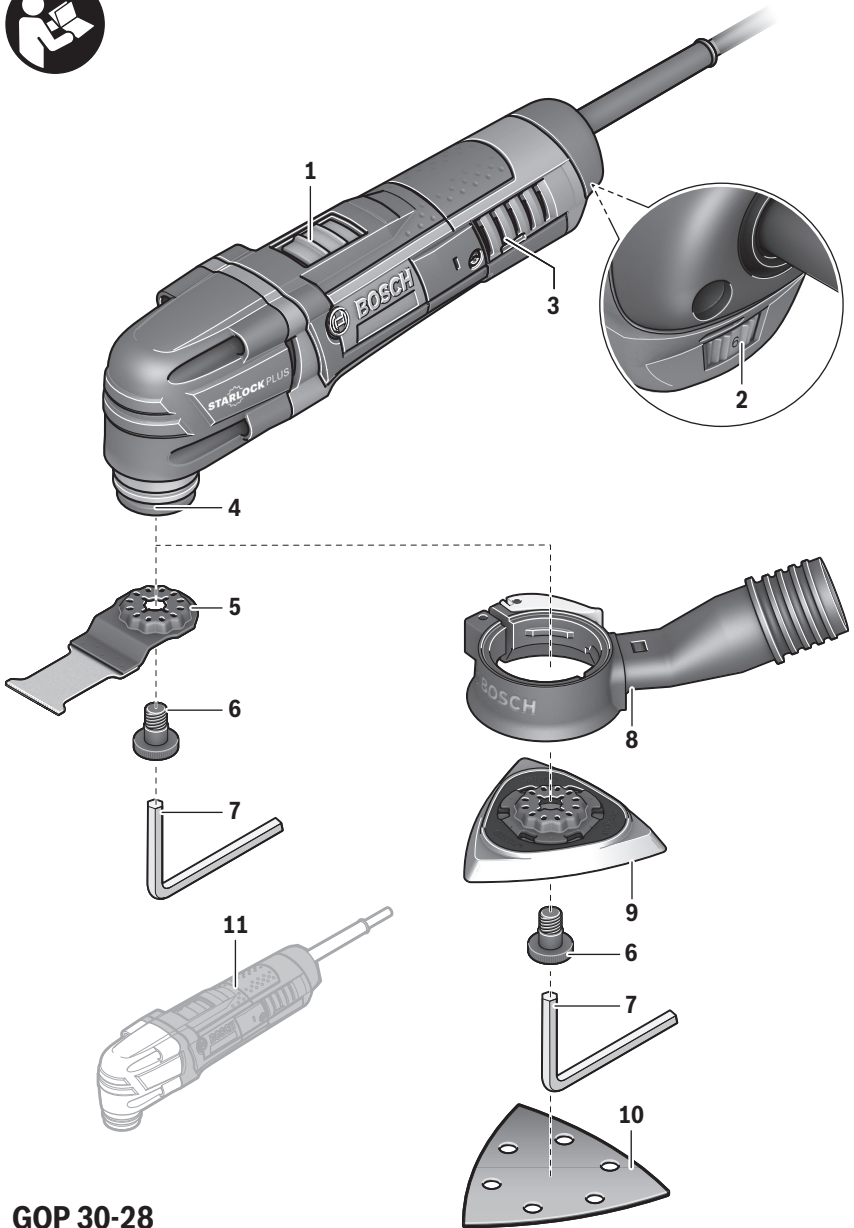

A

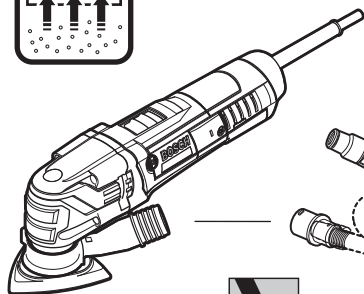
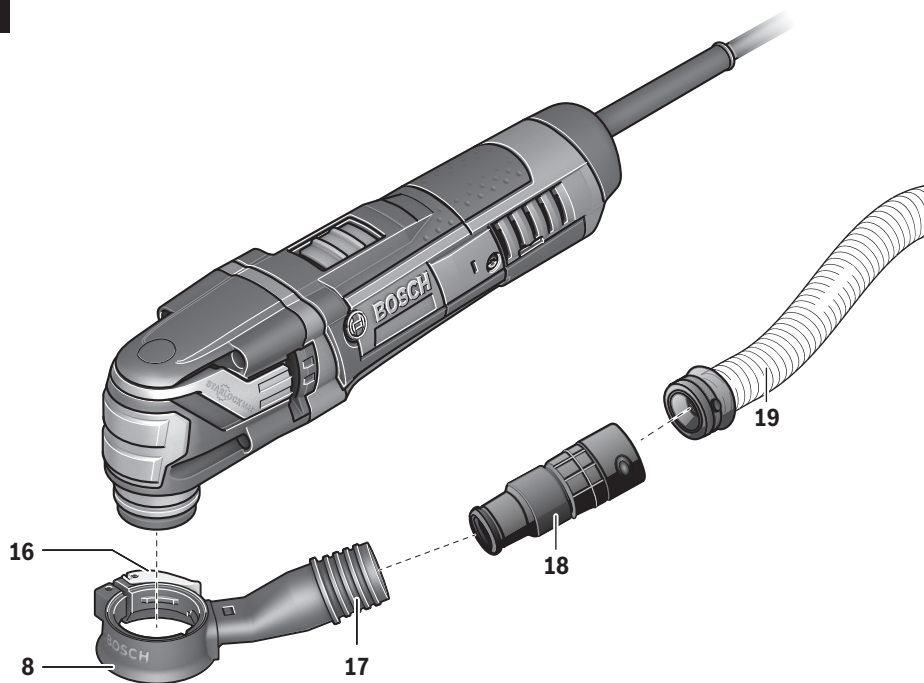

Ø 22 mm:
 2 608 000 572 (3 m)
 2 608 000 568 (5 m)

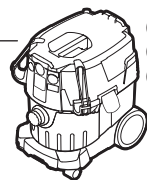

GAS 35 L SFC+
 GAS 35 L AFC
 GAS 35 M AFC

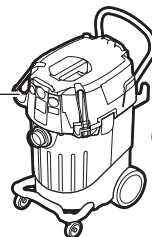

GAS 55 M AFC

English

Safety Notes

General Power Tool Safety Warnings

⚠ WARNING Read all safety warnings and all instructions. Failure to follow the warnings and instructions may result in electric shock, fire and/or serious injury.

Save all warnings and instructions for future reference.

The term "power tool" in the warnings refers to your mains-operated (corded) power tool or battery-operated (cordless) power tool.

Work area safety

- ▶ **Keep work area clean and well lit.** Cluttered or dark areas invite accidents.
- ▶ **Do not operate power tools in explosive atmospheres, such as in the presence of flammable liquids, gases or dust.** Power tools create sparks which may ignite the dust or fumes.
- ▶ **Keep children and bystanders away while operating a power tool.** Distractions can cause you to lose control.

Electrical safety

- ▶ **Power tool plugs must match the outlet. Never modify the plug in any way. Do not use any adapter plugs with earthed (grounded) power tools.** Unmodified plugs and matching outlets will reduce risk of electric shock.
- ▶ **Avoid body contact with earthed or grounded surfaces, such as pipes, radiators, ranges and refrigerators.** There is an increased risk of electric shock if your body is earthed or grounded.
- ▶ **Do not expose power tools to rain or wet conditions.** Water entering a power tool will increase the risk of electric shock.
- ▶ **Do not abuse the cord. Never use the cord for carrying, pulling or unplugging the power tool. Keep cord away from heat, oil, sharp edges and moving parts.** Damaged or entangled cords increase the risk of electric shock.
- ▶ **When operating a power tool outdoors, use an extension cord suitable for outdoor use.** Use of a cord suitable for outdoor use reduces the risk of electric shock.
- ▶ **If operating a power tool in a damp location is unavoidable, use a residual current device (RCD) protected supply.** Use of an RCD reduces the risk of electric shock.

Personal safety

- ▶ **Stay alert, watch what you are doing and use common sense when operating a power tool. Do not use a power tool while you are tired or under the influence of drugs, alcohol or medication.** A moment of inattention while operating power tools may result in serious personal injury.
- ▶ **Use personal protective equipment. Always wear eye protection.** Protective equipment such as dust mask, non-skid safety shoes, hard hat, or hearing protection used for appropriate conditions will reduce personal injuries.

- ▶ **Prevent unintentional starting. Ensure the switch is in the off-position before connecting to power source and/or battery pack, picking up or carrying the tool.** Carrying power tools with your finger on the switch or engaging power tools that have the switch on invites accidents.
- ▶ **Remove any adjusting key or wrench before turning the power tool on.** A wrench or a key left attached to a rotating part of the power tool may result in personal injury.
- ▶ **Do not overreach. Keep proper footing and balance at all times.** This enables better control of the power tool in unexpected situations.
- ▶ **Dress properly. Do not wear loose clothing or jewelry. Keep your hair, clothing and gloves away from moving parts.** Loose clothes, jewellery or long hair can be caught in moving parts.
- ▶ **If devices are provided for the connection of dust extraction and collection facilities, ensure these are connected and properly used.** Use of dust collection can reduce dust-related hazards.

Power tool use and care

- ▶ **Do not force the power tool. Use the correct power tool for your application.** The correct power tool will do the job better and safer at the rate for which it was designed.
- ▶ **Do not use the power tool if the switch does not turn it on and off.** Any power tool that cannot be controlled with the switch is dangerous and must be repaired.
- ▶ **Disconnect the plug from the power source and/or the battery pack from the power tool before making any adjustments, changing accessories, or storing power tools.** Such preventive safety measures reduce the risk of starting the power tool accidentally.
- ▶ **Store idle power tools out of the reach of children and do not allow persons unfamiliar with the power tool or these instructions to operate the power tool.** Power tools are dangerous in the hands of untrained users.
- ▶ **Maintain power tools. Check for misalignment or binding of moving parts, breakage of parts and any other condition that may affect the power tool's operation. If damaged, have the power tool repaired before use.** Many accidents are caused by poorly maintained power tools.
- ▶ **Keep cutting tools sharp and clean.** Properly maintained cutting tools with sharp cutting edges are less likely to bind and are easier to control.
- ▶ **Use the power tool, accessories and tool bits etc. in accordance with these instructions, taking into account the working conditions and the work to be performed.** Use of the power tool for operations different from those intended could result in a hazardous situation.

Service

- ▶ **Have your power tool serviced by a qualified repair person using only identical replacement parts.** This will ensure that the safety of the power tool is maintained.

Safety Warnings for Multi-Cutters

- ▶ **Hold power tool by insulated gripping surfaces, when performing an operation where the cutting accessory may contact hidden wiring or its own cord.** Cutting accessory contacting a "live" wire may make exposed metal parts of the power tool "live" and could give the operator an electric shock.
- ▶ **Use the machine only for dry sanding.** Penetration of water into the machine increases the risk of an electric shock.
- ▶ **Caution, fire hazard! Avoid overheating the object being sanded as well as the sander. Always empty the dust collector before taking breaks.** In unfavourable conditions, e. g., when sparks emit from sanding metals, sanding debris in the dust bag, micro filter or paper sack (or in the filter sack or filter of the vacuum cleaner) can self-ignite. Particularly when mixed with remainders of varnish, polyurethane or other chemical materials and when the sanding debris is hot after long periods of working.
- ▶ **Keep hands away from the sawing range. Do not reach under the workpiece.** Contact with the saw blade can lead to injuries.
- ▶ **Use suitable detectors to determine if utility lines are hidden in the work area or call the local utility company for assistance.** Contact with electric lines can lead to fire and electric shock. Damaging a gas line can lead to explosion. Penetrating a water line causes property damage or may cause an electric shock.
- ▶ **When working with the machine, always hold it firmly with both hands and provide for a secure stance.** The power tool is guided more secure with both hands.
- ▶ **Secure the workpiece.** A workpiece clamped with clamping devices or in a vice is held more secure than by hand.
- ▶ **Wear protective gloves when changing application tools/accessories.** Application tools/accessories become hot after prolonged usage.
- ▶ **Do not scrape wetted materials (e. g. wallpaper) or on moist surfaces.** Penetration of water into the machine increases the risk of an electric shock.
- ▶ **Do not treat the surface to be worked with solvent-containing fluids.** Materials being warmed up by the scraping can cause toxic vapours to develop.
- ▶ **Exercise extreme caution when handling the scraper.** The accessory is very sharp; danger of injury.

Products sold in GB only: Your product is fitted with an BS 1363/A approved electric plug with internal fuse (ASTA approved to BS 1362).

If the plug is not suitable for your socket outlets, it should be cut off and an appropriate plug fitted in its place by an authorised customer service agent. The replacement plug should have the same fuse rating as the original plug. The severed plug must be disposed of to avoid a possible shock hazard and should never be inserted into a mains socket elsewhere.

Product Description and Specifications



Read all safety warnings and all instructions. Failure to follow the warnings and instructions may result in electric shock, fire and/or serious injury.

While reading the operating instructions, unfold the graphics page for the machine and leave it open.

Intended Use

GOP 30-28/GOP 40-30/GOP 55-36

The machine is intended for sawing and cutting wooden materials, plastic, gypsum, non-ferrous metals and fastening elements (e. g., unhardened nails, staples). It is also suitable for working soft wall tiles, as well as for dry sanding and scraping of small surfaces. It is especially suitable for working close to edges and for flush cutting. Operate the power tool exclusively with Bosch accessories.

GOP 40-30

The light of this power tool is intended to illuminate the power tool's direct area of working operation and is not suitable for household room illumination.

Product Features

The numbering of the product features refers to the illustration of the machine on the graphics page.

- 1 On/Off switch
- 2 Thumbwheel for orbit frequency preselection
- 3 Venting slots
- 4 Tool holder
- 5 Plunge saw blade*
- 6 Clamping bolt (GOP 30-28)
- 7 Hex key (GOP 30-28)
- 8 Dust extraction*
- 9 Sanding plate*
- 10 Sanding sheet*
- 11 Handle (insulated gripping surface)
- 12 SDS lever for releasing the application tool (GOP 40-30/GOP 55-36)
- 13 Worklight (GOP 40-30)
- 14 Clamping lever of the depth stop*
- 15 Depth stop*
- 16 Clamping lever of the dust extraction*
- 17 Vacuum connection*
- 18 Tool sleeve*
- 19 Vacuum hose*

*Accessories shown or described are not part of the standard delivery scope of the product. A complete overview of accessories can be found in our accessories program.

Technical Data

Multi-Cutter		GOP 30-28	GOP 40-30	GOP 55-36
Article number		3 601 237 0..	3 601 B31 0..	3 601 B31 1..
Preselection of orbital stroke rate		●	●	●
Rated power input	W	300	400	550
No-load speed n_0	min ⁻¹	8000–20000	8000–20000	8000–20000
Oscillation angle, left/right	°	1.4	1.5	1.8
Weight according to EPTA-Procedure 01:2014	kg	1.5	1.5	1.6
Protection class		□/II	□/II	□/II

The values given are valid for a nominal voltage [U] of 230 V. For different voltages and models for specific countries, these values can vary.

Noise/Vibration Information

		GOP 30-28	GOP 40-30	GOP 55-36
Sound emission values determined according to EN 60745-2-4.				
Typically the A-weighted noise levels of the product are				
Sound pressure level	dB(A)	81	80	81
Sound power level	dB(A)	92	91	92
Uncertainty K	dB	3	3	3
Wear hearing protection!				
Vibration total values a_{h1} (triax vector sum) and uncertainty K determined according to EN 60745-2-4:				
Sanding:				
a_h	m/s ²	2	3	3.5
K	m/s ²	1.5	1.5	1.5
Sawing with plunge cut saw blade:				
a_h	m/s ²	10	11	10.5
K	m/s ²	1.5	1.5	1.5
Sawing with segment saw blade:				
a_h	m/s ²	6.5	6.5	6.5
K	m/s ²	1.5	1.5	1.5
Scraping:				
a_h	m/s ²	4.5	6.0	6.5
K	m/s ²	1.5	1.5	1.5

The vibration level given in this information sheet has been measured in accordance with a standardised test given in EN 60745 and may be used to compare one tool with another. It may be used for a preliminary assessment of exposure. The declared vibration emission level represents the main applications of the tool. However if the tool is used for different applications, with different accessories or insertion tools or is poorly maintained, the vibration emission may differ. This may significantly increase the exposure level over the total working period.

An estimation of the level of exposure to vibration should also take into account the times when the tool is switched off or when it is running but not actually doing the job. This may significantly reduce the exposure level over the total working period.



Identify additional safety measures to protect the operator from the effects of vibration such as: maintain the tool and the accessories, keep the hands warm, organisation of work patterns.

Assembly

Changing the Tool

- ▶ **Before any work on the machine itself, pull the mains plug.**
- ▶ **Wear protective gloves when changing application tools/accessories.** Contact with the application tool/accessory can lead to injuries.

Selecting the Application Tool/Accessory

Accessory		GOP 30-28 GOP 40-30	GOP 55-36
STARLOCK 		✓	✓
STARLOCK PLUS 		✓	✓





Accessory

GOP 30-28 GOP 55-36
 GOP 40-30



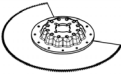

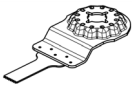
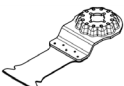

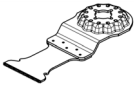
Selecting the Application Tool/Accessory

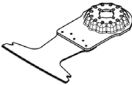
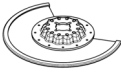
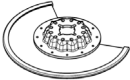
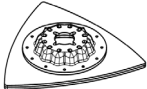
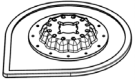
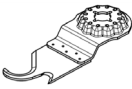
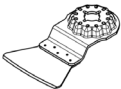
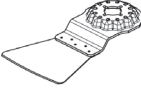
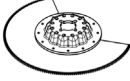
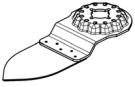
The following table shows examples for application tools. Further application tools can be found in the extensive Bosch accessories program.

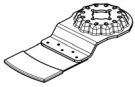
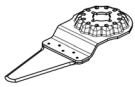
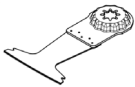
Accessory	Material	Application
 <p>BIM segment saw blade</p>	Wooden materials, Plastic, Non-ferrous metals	Separating and plunge cuts; also for sawing close to edges, in corners and hard to reach areas; example: shortening already installed bottom rails or door hinges, plunge cuts for adjusting floor panels
 <p>Base plate for sanding, series Delta 93 mm</p>	Depends on sanding sheet	Sanding surfaces close to edges, in corners or hard to reach areas; depending on the sanding sheet for, e. g., sanding wood, paint, varnish, stone Fleeces for cleaning and for texturing wood, removing rust from metal and for keying varnishes, polishing felt for pre-polishing
 <p>Profile sander</p>	Wood, Pipes/Profile, Paint, Varnishes, Filler, Metal	Convenient, efficient sanding of profiles up to a diameter of 55 mm; Red sanding sheets for sanding wood, pipes/profiles, varnishes, fillers and metal
 <p>BIM plunge cut saw blade, wood and metal</p>	Softwood, Soft plastics, Plasterboard, Thin-walled aluminium and non-ferrous metal profiles, Thin sheet metals, Non-hardened nails and screws	Smaller separating and plunge cuts; example: cutting an opening for sockets, flush cutting a copper pipe, plunge cuts in plasterboard Filigree adjustment work in wood; example: sawing openings for locks and fittings
 <p>HCS plunge cut saw blade, wood</p>	Wooden materials, Soft plastics	Separating and deep plunge cuts; also for sawing close to edges, in corners and hard to reach areas; example: narrow plunge cut in solid wood for installing a ventilation grid
 <p>Bi-metal plunge cut saw blade, hardwood</p>	Hardwood, Laminated panels	Plunge cuts in laminated panels or hardwood; example: installing skylights
 <p>TC plunge cut saw blade, metal</p>	Metal, Severely abrasive materials, Fibreglass, Plasterboard, Cement-bonded fibre boards	Plunge cuts in severely abrasive materials or metal; example: cutting kitchen front covers, easy cutting through hardened screws, nails and stainless steel

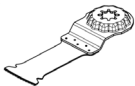
Accessory	Material	Application
	Softwood, Hardwood, Veneered panels, Plastic-laminated panels, Non-hardened nails and screws	Plunge cuts in laminated panels or hardwood; example: shortening door frames, cutting openings for a shelf
	Cement joints, Soft wall tiles, Glass fibre reinforced plastics, Porous concrete	Cutting and separating close to edges, in corners or hard to reach areas; example: removing grouting joints between wall tiles for repair work, cutting openings in tiles, gypsum boards or plastic
	Cement joints, Soft wall tiles, Epoxy resin, Glass fibre reinforced plastics	Precise routing and cutting of tile/joint material, epoxy resins and glass fibre reinforced plastics; example: making smaller cutouts in soft wall tiles and routing openings in glass fibre reinforced plastic
	Mortar, Concrete residues, Wood, Abrasive materials	Rasping and sanding on hard surfaces; example: removing mortar or tile adhesive (e.g. when replacing damaged tiles), removing carpet adhesive residues
	Mortar, Joints, Epoxy resin, Glass fibre reinforced plastics, Abrasive materials	Routing and cutting joint and tile material and rasping and sanding on hard surfaces; example: removing tile adhesive and grout
	Roofing felt, Carpets, Artificial turf, Cardboard, PVC flooring	Fast, precise cutting of soft material and flexible abrasive materials; example: cutting carpets, cardboard, PVC flooring, roofing felt, etc.
	Carpets, Mortar, Concrete, Tile adhesive	Scraping on hard surfaces; example: removing mortar, tile adhesive, concrete and carpet adhesive residues
	Carpet adhesive, Paint residues, Silicone	Flexible scraping on soft surfaces; example: removing silicone joints, carpet adhesive and paint residues
	Insulation material, Insulation panels, Floor panels, Sound-dampening floor panels, Cardboard, Carpets, Rubber, Leather	Precise cutting of soft materials; example: cutting insulation panels to size, flush cutting protruding insulation material to length
	Wood, Paint	Sanding wood or paint in hard to reach areas without sanding paper; example: sanding off paint between shutter louvres, sanding wooden floors in corners

Accessory	Material	Application
 HM-Riff plunge cut saw blade	Fibreglass, Mortar, Wood	Plunge cuts in severely abrasive materials; example: routing thin mosaic tiles
 HCS universal joint cutter	Expansion joints, Putty, Insulation materials (rock wool)	Cutting and separating soft materials; example: cutting silicone expansion joints or putty
 BIM plunge cut saw blade, wood and metal	Softwood, Hardwood, Veneered panels, Plastic-laminated panels, Non-hardened nails and screws	Fast, deep plunge cuts in wood and metal; example: quick cutting of wood containing nails, deep plunge cuts in laminated panels and precise shortening of door frames
 TC plunge cut saw blade, metal	Stainless steel (Inox), Screws and nails, Epoxy resin, Glass fibre reinforced plastics, Fibreglass, Plasterboard, Porous concrete	Fast, deep plunge cuts in severely abrasive materials or metal; example: fast cutting of kitchen front covers, easy cutting through hardened screws, nails and stainless steel
 BIM plunge cut saw blade, wood and metal	Wood, Abrasive wooden materials, Plastics, Hardened nails and screws, Non-ferrous metal pipes	Fast, deep plunge cuts in wood, abrasive wooden materials and plastics; example: fast cutting of non-ferrous metal pipes and profiles with smaller dimensions, easy cutting of non-hardened nails, screws and steel profiles with smaller dimensions
 HCS plunge cut saw blade, wood	Softwood, Dowels, Tenons, Furniture components	Fast, deep separating and plunge cuts; also for sawing close to edges in corners and hard to reach areas; example: deep plunge cut in softwood for installing a ventilation grid

Mounting/Replacing the Application Tool/Accessory (GOP 30-28)

If required, remove an already mounted application tool/accessory.

For removing the application tool/accessory, loosen the screw **6** with the hex key **7** and remove the application tool/accessory.

Mount the requested application tool/accessory (e.g. plunge cut saw blade **5**) in such a manner on the tool holder **4** that the offset faces downward (see illustration on the graphics page; marking on the application tool/accessory is readable from above).

Turn the application tool/accessory to a position favourable for the respective job, and allow it to engage into the cams of the tool holder **4**. 12 different positions are possible, each offset by 30°.

Fasten the application tool/accessory with bolt **6**. Tighten the bolt with hex key **7** until the spring washer of the bolt faces flush against the application tool/accessory.

► **Check the tight seating of the application tool/accessory.** Incorrect or not securely fastened application tools/accessories can come loose during operation and pose a hazard.

Mounting/Replacing the Application Tool/Accessory (GOP 40-30/GOP 55-36)

If required, remove an already mounted application tool/accessory.

To do so, open the SDS lever **12** all the way. The application tool/accessory will be ejected.

Mount the requested application tool/accessory (e.g. plunge cut saw blade **5**) in such a manner on the tool holder **4** that the offset faces downward (see illustration on the graphics page; marking on the application tool/accessory is readable from above).

When doing so, place the application tool/accessory in a position which is convenient for the job at hand. Twelve different positions are possible, each offset by 30°.

Press the application tool/accessory in the required position firmly onto the clamping jaws of the tool holder until it is automatically locked.

- ▶ **Check the tight seating of the application tool/accessory.** Incorrect or not securely fastened application tools/accessories can come loose during operation and pose a hazard.

Mounting and Adjusting the Depth Stop

The depth stop **15** can be used when working with segment and plunge cut saw blades.

If required, remove an already mounted application tool/accessory.

Slide the depth stop **15** in the required work position all the way over the tool holder **4** onto the collar of the power tool. Allow the depth stop to engage. Twelve different positions are possible, each offset by 30°.

Set the required working depth. Press shut the clamping lever **14** of the depth stop in order to fix the depth stop.

Mounting/Replacing a Sanding Sheet on the Sanding Plate

The sanding plate **9** is fitted with Velcro backing for quick and easy fastening of sanding sheets with Velcro adhesion.

Before attaching the sanding sheet **10**, free the Velcro backing of the sanding plate **9** from any debris by tapping against it in order to enable optimum adhesion.

Position the sanding sheet **10** flush alongside one edge of the sanding plate **9**, then lay the sanding sheet onto the sanding plate and press firmly.

To ensure optimum dust extraction, pay attention that the punched holes in the sanding sheet match with the holes in the sanding plate.

To remove the sanding sheet **10**, grasp it at one of the tips and pull it off from the sanding plate **9**.

You can use all sanding sheets, fleece pads/polishing cloth pads of the Delta 93 mm series of Bosch accessory program. Sanding accessories, such as fleece pads/polishing cloth pads, are attached to the sanding plate in the same manner.

Selecting the Sanding Sheet

Depending on the material to be worked and the required rate of material removal, different sanding sheets are available:

Sanding disc	Material	Application	Grain size	
best for Wood	<ul style="list-style-type: none"> – All wooden materials (e. g., hardwood, softwood, chipboard, building board) – Metal materials 	For coarse-sanding, e. g. of rough, unplanned beams and boards	coarse	40 60
		For face sanding and planing small irregularities	medium	80 100 120
		For finish and fine sanding of wood	fine	180 240 320 400
best for Paint	<ul style="list-style-type: none"> – Paint – Varnish – Filling compound – Filler 	For sanding off paint	coarse	40 60
		For sanding primer (e. g., for removing brush dashes, drops of paint and paint run)	medium	80 100 120
		For final sanding of primers before coating	fine	180 240 320 400

Dust/Chip Extraction

- ▶ Dust from materials such as lead-containing coatings, some wood types, minerals and metal can be harmful to one's health. Touching or breathing-in the dust can cause allergic reactions and/or lead to respiratory infections of the user or bystanders.

Certain dust, such as oak or beech dust, is considered carcinogenic, especially in connection with wood-treatment additives (chromate, wood preservative). Materials containing asbestos may only be worked by specialists.

- As far as possible, use a dust extraction system suitable for the material.

- Provide for good ventilation of the working place.
- It is recommended to wear a P2 filter-class respirator. Observe the relevant regulations in your country for the materials to be worked.

- ▶ **Prevent dust accumulation at the workplace.** Dust can easily ignite.

Connecting the Dust Extraction (see figure A)

The dust extraction **8** is intended only when working with the sanding plate **9**; it is not of use in combination with other application tools.

For sanding, always connect the dust extraction.

To mount the dust extraction **8** (accessory), remove the application tool and the depth stop **15**.

Slide the dust extraction **8** all the way over the tool holder **4** onto the collar of the power tool. Turn it to the required position. Press shut the clamping lever **16** to fix the dust extraction.

Plug the tool sleeve **18** of the vacuum hose **19** onto the vacuum connection **17**. Connect the vacuum hose **19** to a vacuum cleaner (accessory). You will find an overview of connecting to various vacuum cleaners on the fold-out page.

The vacuum cleaner must be suitable for the material being worked.

When vacuuming dry dust that is especially detrimental to health or carcinogenic, use a special vacuum cleaner.

Operation

- ▶ **Observe correct mains voltage! The voltage of the power source must agree with the voltage specified on the nameplate of the machine. Power tools marked with 230 V can also be operated with 220 V.**

Products sold in AUS and NZ only: Use a residual current device (RCD) with a rated residual current of 30 mA or less.

Starting Operation

Switching On and Off

To **start** the machine, push the On/Off switch **1** forward so that the “**I**” is indicated on the switch.

To **switch off** the machine, push the On/Off switch **1** toward the rear so that the “**O**” is indicated on the switch.

To save energy, only switch the power tool on when using it. GOP 40-30: The worklight improves visibility in the immediate work area. It is automatically switched on and off with the power tool.

- ▶ **Do not look directly into the work area illumination – your sight can be temporarily degraded!**

Preselecting the Orbital Stroke Rate

With the thumbwheel for preselection of the orbital stroke rate **2**, you can preselect the required orbital stroke rate, even during operation.

The required stroke rate depends on the material and the working conditions and can be determined through practical testing.

Working Advice

- ▶ **Before any work on the machine itself, pull the mains plug.**
- ▶ **Wait until the machine has come to a standstill before placing it down.**

Note: Do not cover off the venting slots **3** of the machine while working, as this reduces the working life of the machine.

Operating Principle

The oscillating drive causes the application tool/accessory to oscillate back and forth up to 20 000 times per minute. This enables precise work in the tightest of spaces.



Work with low and uniform application pressure, otherwise, the working performance will decline and the application tool can become blocked.



While working, move the machine back and forth, so that the application tool does not heat up excessively and become blocked.

Sawing

- ▶ **Use only undamaged saw blades that are in perfect condition.** Bent or dull saw blades can break, negatively influence the cut, or lead to kickback.
- ▶ **When sawing light building materials, observe the statutory provisions and the recommendations of the material suppliers.**
- ▶ **Plunge cuts may only be applied to soft materials, such as wood, gypsum plaster boards, etc.!**

Before sawing with HCS saw blades in wood, particle board, building materials, etc., check these for foreign objects such as nails, screws, or similar. If required, remove foreign objects or use BIM saw blades.

Separating

Note: When separating wall tiles take into consideration that the application tools/accessories wear heavily when used for longer periods of time.

Sanding

The removal rate and the sanding pattern are primarily determined by the choice of sanding sheet, the preset oscillation rate and the applied pressure.

Only flawless sanding sheets achieve good sanding capacity and extend the service life of the machine.

Pay attention to apply uniform sanding pressure; this increases the working life of the sanding sheets.

Intensifying the sanding pressure does not lead to an increase of the sanding capacity, but to increased wear of the machine and the sanding sheet.

For precise on-the-spot sanding of edges, corners and hard to reach areas, it is also possible to work only with the tip or an edge of the sanding plate.

When selectively sanding on the spot, the sanding sheet can heat up considerably. Reduce the orbital stroke rate and the sanding pressure, and allow the sanding sheet to cool down regularly.

A sanding sheet that has been used for metal should not be used for other materials.

Use only original Bosch sanding accessories.

For sanding, always connect the dust extraction.

Scraping

For scraping, select a high oscillation rate.

Work on a soft surface (e.g. wood) at a flat angle, and apply only light pressure. Otherwise the scraper can cut into the surface.

Maintenance and Service

Maintenance and Cleaning

- ▶ **Before any work on the machine itself, pull the mains plug.**
- ▶ **For safe and proper working, always keep the machine and ventilation slots clean.**

Clean Riff application tools (accessory) regularly with a wire brush.

If the replacement of the supply cord is necessary, this has to be done by Bosch or an authorized Bosch service agent in order to avoid a safety hazard.

After-sales Service and Application Service

Our after-sales service responds to your questions concerning maintenance and repair of your product as well as spare parts. Exploded views and information on spare parts can also be found under:

www.bosch-pt.com

Bosch's application service team will gladly answer questions concerning our products and their accessories.

In all correspondence and spare parts orders, please always include the 10-digit article number given on the nameplate of the product.

Great Britain

Robert Bosch Ltd. (B.S.C.)
P.O. Box 98
Broadwater Park
North Orbital Road
Denham
Uxbridge
UB 9 5HJ

At www.bosch-pt.co.uk you can order spare parts or arrange the collection of a product in need of servicing or repair.

Tel. Service: (0344) 7360109

E-Mail: boschservicecentre@bosch.com

Ireland

Origo Ltd.
Unit 23 Magna Drive
Magna Business Park
City West
Dublin 24
Tel. Service: (01) 4666700
Fax: (01) 4666888

Australia, New Zealand and Pacific Islands

Robert Bosch Australia Pty. Ltd.
Power Tools
Locked Bag 66
Clayton South VIC 3169
Customer Contact Center
Inside Australia:
Phone: (01300) 307044
Fax: (01300) 307045

Inside New Zealand:
Phone: (0800) 543353
Fax: (0800) 428570

Outside AU and NZ:
Phone: +61 3 95415555
www.bosch-pt.com.au
www.bosch-pt.co.nz

Republic of South Africa

Customer service

Hotline: (011) 6519600

Gauteng – BSC Service Centre

35 Roper Street, New Centre
Johannesburg
Tel.: (011) 4939375
Fax: (011) 4930126
E-Mail: bsctools@icon.co.za

KZN – BSC Service Centre

Unit E, Almar Centre
143 Crompton Street
Pinetown
Tel.: (031) 7012120
Fax: (031) 7012446
E-Mail: bsc.dur@za.bosch.com

Western Cape – BSC Service Centre

Democracy Way, Prosperity Park
Milnerton
Tel.: (021) 5512577
Fax: (021) 5513223
E-Mail: bsc@zsd.co.za

Bosch Headquarters

Midrand, Gauteng
Tel.: (011) 6519600
Fax: (011) 6519880
E-Mail: rbsa-hq.pts@za.bosch.com

Disposal

The machine, accessories and packaging should be sorted for environmental-friendly recycling.



Do not dispose of power tools into household waste!

Only for EC countries:

According to the European Guideline 2012/19/EU for Waste Electrical and Electronic Equipment and its implementation into national right, power tools that are no longer usable must be collected separately and disposed of in an environmentally correct manner.

Subject to change without notice.

STARLOCK



2 608 661 640 (20 mm, BIM)
2 608 661 641 (10 mm, BIM)
2 608 662 019 (20 mm, Carbide)



2 608 661 691 (28 mm, HCS)



2 608 661 644 (32,5 mm, BIM)
2 608 661 645 (32,5 mm, BIM)
2 608 661 688 (32,5 mm, BIM)
2 608 662 018 (32,5 mm, Carbide)
2 608 662 360 (32,5 mm, HCS)
2 608 661 637 (32,5 mm, HCS)



2 608 661 868 (33,6 mm, Carbide)



2 608 662 431 (32,5 mm, HCS)



2 608 661 646 (52 mm, HCS)
2 608 661 647 (52 mm, HCS)



2 608 661 781 (64,3 mm, BIM)
2 608 662 017 (64,4 mm, BIM)
2 608 662 357 (64,3 mm, HCS)
2 608 662 354 (64,4 mm, HCS)



2 608 662 610 (32,5 mm, Carbide)
2 608 662 611 (32,5 mm, Carbide)

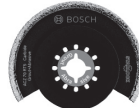

2 608 661 692 (Ø 70 mm, Carbide)
2 608 661 689 (Ø 86 mm, Diamond)
2 608 661 642 (Ø 86 mm, Carbide)



2 608 661 636 (Ø 85 mm, BIM)
2 608 661 758 (Ø 85 mm, BIM-Tin)
2 608 661 643 (Ø 87 mm, HCS)
2 608 661 633 (Ø 95,5 mm, BIM)
2 608 661 693 (Ø 95,5 mm, BIM)



2 608 661 757
(87 x 71,4 mm, Carbide)



2 608 661 648
(78 x 73 mm, Carbide)



2 608 000 493 (85,6 x 90,8 mm)



2 608 662 346 (64,5 mm)

STARLOCK PLUS



2 608 662 555 (32,5 mm, Carbide)
2 608 662 558 (32,5 mm, BIM)
2 608 662 561 (32,5 mm, HCS)



2 608 662 564 (64,7 mm, BIM)

STARLOCK MAX



2 608 662 567 (32,5 mm, Carbide)
2 608 662 568 (32,5 mm, HCS)
2 608 662 571 (32,5 mm, BIM)
2 608 662 574 (52 mm, BIM)



2 608 662 577 (68,5 mm, Carbide)
2 608 662 578 (68,4 mm, Carbide)
2 608 662 579 (66,1 mm, HCS)
2 608 662 580 (68,3 mm, Diamond)
2 608 662 581 (68,4 mm, Diamond)
2 608 662 582 (68,4 mm, Carbide)



2 608 662 575 (10,7 mm, HCS)



2 608 662 583 (29,2 mm, HCS)

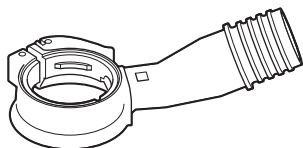

2 608 000 636

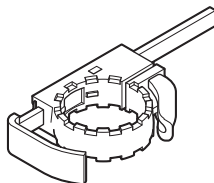

2 608 000 590