

GKS 190 Professional



BOSCH

de Originalbetriebsanleitung
en Original instructions
fr Notice originale
es Manual original
pt Manual original
it Istruzioni originali
nl Oorspronkelijke gebruiksaanwijzing
da Original brugsanvisning
sv Bruksanvisning i original
no Original driftsinstruks
fi Alkuperäiset ohjeet
el Πρωτότυπο οδηγιών χρήσης

tr Orijinal işletme talimatı
pl Instrukcja oryginalna
cs Původní návod k používání
sk Pôvodný návod na použitie
hu Eredeti használati utasítás
ru Оригинальное руководство по эксплуатации
uk Оригінальна інструкція з експлуатації
kk Пайдалану нұсқаулығының түпнұсқасы
ro Instrucțiuni originale

bg Оригинална инструкция
mk Оригинално упатство за работа
sr Originalno uputstvo za rad
sl Izvirna navodila
hr Originalne upute za rad
et Algupärane kasutusjuhend
lv Instrukcijas oriģinālvalodā
lt Originali instrukcija
ar تعليمات التشغيل الأصلية
fa دفترچه راهنمای اصلی



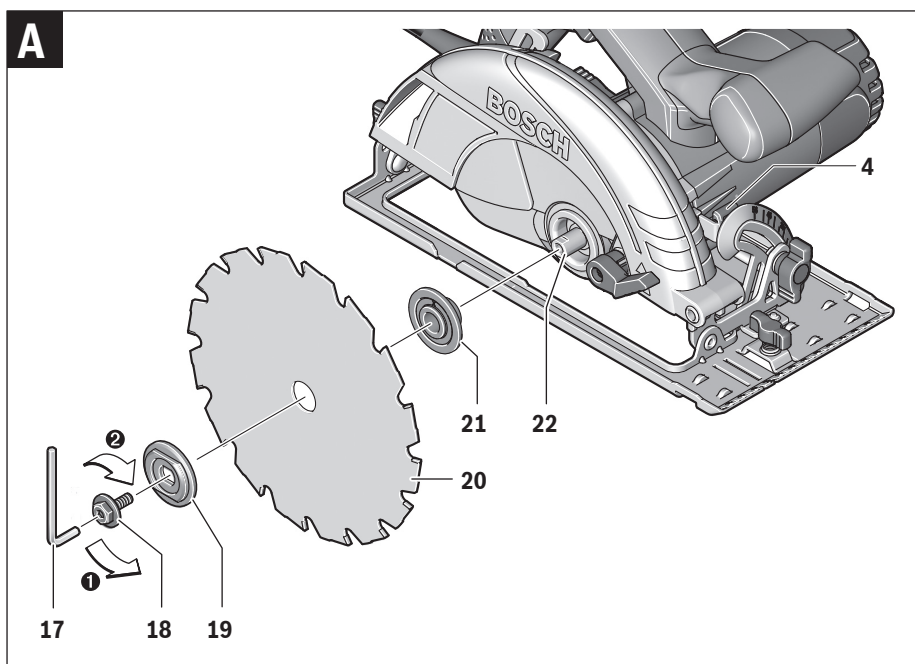
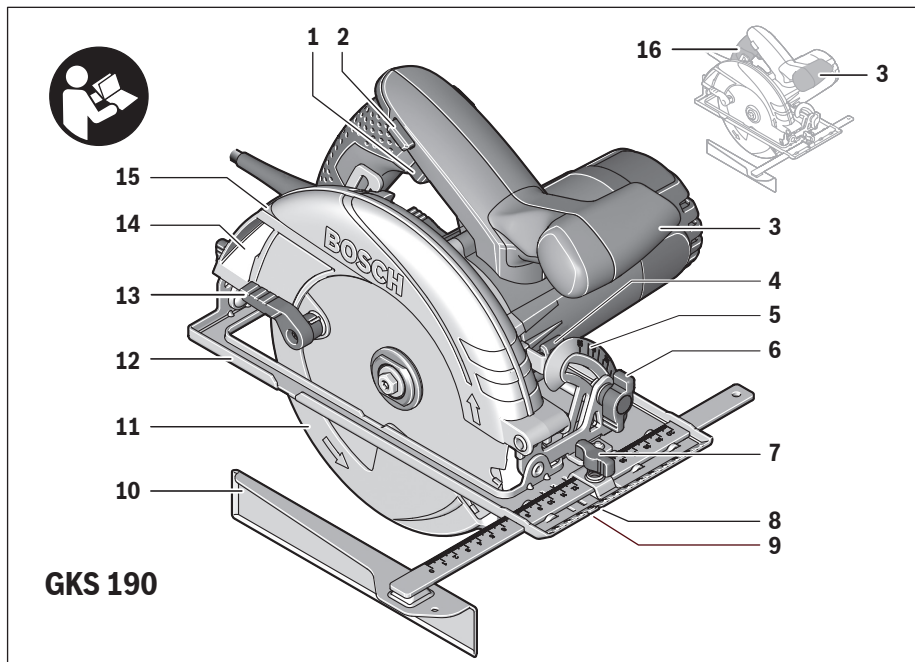

Die Pendelschutzhaube muss sich immer frei bewegen und selbstständig schließen können. Halten Sie deshalb den Bereich um die Pendelschutzhaube stets sauber. Entfernen Sie Staub und Späne durch Ausblasen mit Druckluft oder mit einem Pinsel.

Nicht beschichtete Sägeblätter können durch eine dünne Schicht säurefreies Öl vor Korrosionsansatz geschützt werden. Entfernen Sie vor dem Sägen das Öl wieder, weil Holz sonst fleckig wird.

Harz- oder Leimreste auf dem Sägeblatt beeinträchtigen die Schnittqualität. Reinigen Sie deshalb Sägeblätter gleich nach dem Gebrauch.

Wenn ein Ersatz der Anschlussleitung erforderlich ist, dann ist dies von Bosch oder einer autorisierten Kundendienststelle für Bosch-Elektrowerkzeuge auszuführen, um Sicherheitsgefährdungen zu vermeiden.

Kundendienst und Anwendungsberatung

Geben Sie bei allen Rückfragen und Ersatzteilbestellungen bitte unbedingt die 10-stellige Sachnummer laut Typenschild des Elektrowerkzeuges an.

Der Kundendienst beantwortet Ihre Fragen zu Reparatur und Wartung Ihres Produkts sowie zu Ersatzteilen. Explosionszeichnungen und Informationen zu Ersatzteilen finden Sie auch unter:

www.bosch-pt.com

Das Bosch-Anwendungsberatungs-Team hilft Ihnen gerne bei Fragen zu unseren Produkten und deren Zubehör.

www.powertool-portal.de, das Internetportal für Handwerker und Heimwerker.

Deutschland

Robert Bosch Power Tools GmbH
Servicezentrum Elektrowerkzeuge
Zur Luhne 2

37589 Kalefeld – Willershausen

Unter www.bosch-pt.de können Sie online Ersatzteile bestellen oder Reparaturen anmelden.

Kundendienst: Tel.: (0711) 40040480

Fax: (0711) 40040481

E-Mail: Servicezentrum.Elektrowerkzeuge@de.bosch.com

Anwendungsberatung: Tel.: (0711) 40040480

Fax: (0711) 40040482

E-Mail: Anwendungsberatung.pt@de.bosch.com

Österreich

Unter www.bosch-pt.at können Sie online Ersatzteile bestellen.

Tel.: (01) 797222010

Fax: (01) 797222011

E-Mail: service.elektrowerkzeuge@at.bosch.com

Schweiz

Unter www.bosch-pt.com/ch/de können Sie online Ersatzteile bestellen.

Tel.: (044) 8471511

Fax: (044) 8471551

E-Mail: AfterSales.Service@de.bosch.com

Luxemburg

Tel.: +32 2 588 0589

Fax: +32 2 588 0595

E-Mail: outillage.gereedschap@be.bosch.com

Entsorgung

Elektrowerkzeuge, Zubehör und Verpackungen sollen einer umweltgerechten Wiederverwertung zugeführt werden.

Werfen Sie Elektrowerkzeuge nicht in den Hausmüll!

Nur für EU-Länder:



Gemäß der Europäischen Richtlinie 2012/19/EU über Elektro- und Elektronik-Altgeräte und ihrer Umsetzung in nationales Recht müssen nicht mehr gebrauchsfähige Elektrowerkzeuge getrennt gesammelt und einer umweltgerechten Wiederverwertung zugeführt werden.

Änderungen vorbehalten.

English

Safety Notes

General Power Tool Safety Warnings

⚠ WARNING Read all safety warnings and all instructions. Failure to follow the warnings and instructions may result in electric shock, fire and/or serious injury.

Save all warnings and instructions for future reference.

The term “power tool” in the warnings refers to your mains-operated (corded) power tool or battery-operated (cordless) power tool.

Work area safety

- ▶ **Keep work area clean and well lit.** Cluttered or dark areas invite accidents.
- ▶ **Do not operate power tools in explosive atmospheres, such as in the presence of flammable liquids, gases or dust.** Power tools create sparks which may ignite the dust or fumes.
- ▶ **Keep children and bystanders away while operating a power tool.** Distractions can cause you to lose control.

Electrical safety

- ▶ **Power tool plugs must match the outlet. Never modify the plug in any way. Do not use any adapter plugs with earthed (grounded) power tools.** Unmodified plugs and matching outlets will reduce risk of electric shock.
- ▶ **Avoid body contact with earthed or grounded surfaces, such as pipes, radiators, ranges and refrigerators.** There is an increased risk of electric shock if your body is earthed or grounded.
- ▶ **Do not expose power tools to rain or wet conditions.** Water entering a power tool will increase the risk of electric shock.

- ▶ **Do not abuse the cord. Never use the cord for carrying, pulling or unplugging the power tool. Keep cord away from heat, oil, sharp edges and moving parts.** Damaged or entangled cords increase the risk of electric shock.
- ▶ **When operating a power tool outdoors, use an extension cord suitable for outdoor use.** Use of a cord suitable for outdoor use reduces the risk of electric shock.
- ▶ **If operating a power tool in a damp location is unavoidable, use a residual current device (RCD) protected supply.** Use of an RCD reduces the risk of electric shock.

Personal safety

- ▶ **Stay alert, watch what you are doing and use common sense when operating a power tool. Do not use a power tool while you are tired or under the influence of drugs, alcohol or medication.** A moment of inattention while operating power tools may result in serious personal injury.
- ▶ **Use personal protective equipment. Always wear eye protection.** Protective equipment such as dust mask, non-skid safety shoes, hard hat, or hearing protection used for appropriate conditions will reduce personal injuries.
- ▶ **Prevent unintentional starting. Ensure the switch is in the off-position before connecting to power source and/or battery pack, picking up or carrying the tool.** Carrying power tools with your finger on the switch or energising power tools that have the switch on invites accidents.
- ▶ **Remove any adjusting key or wrench before turning the power tool on.** A wrench or a key left attached to a rotating part of the power tool may result in personal injury.
- ▶ **Do not overreach. Keep proper footing and balance at all times.** This enables better control of the power tool in unexpected situations.
- ▶ **Dress properly. Do not wear loose clothing or jewellery. Keep your hair, clothing and gloves away from moving parts.** Loose clothes, jewellery or long hair can be caught in moving parts.
- ▶ **If devices are provided for the connection of dust extraction and collection facilities, ensure these are connected and properly used.** Use of dust collection can reduce dust-related hazards.

Power tool use and care

- ▶ **Do not force the power tool. Use the correct power tool for your application.** The correct power tool will do the job better and safer at the rate for which it was designed.
- ▶ **Do not use the power tool if the switch does not turn it on and off.** Any power tool that cannot be controlled with the switch is dangerous and must be repaired.
- ▶ **Disconnect the plug from the power source and/or the battery pack from the power tool before making any adjustments, changing accessories, or storing power tools.** Such preventive safety measures reduce the risk of starting the power tool accidentally.
- ▶ **Store idle power tools out of the reach of children and do not allow persons unfamiliar with the power tool or these instructions to operate the power tool.** Power tools are dangerous in the hands of untrained users.

- ▶ **Maintain power tools. Check for misalignment or binding of moving parts, breakage of parts and any other condition that may affect the power tool's operation. If damaged, have the power tool repaired before use.** Many accidents are caused by poorly maintained power tools.
- ▶ **Keep cutting tools sharp and clean.** Properly maintained cutting tools with sharp cutting edges are less likely to bind and are easier to control.
- ▶ **Use the power tool, accessories and tool bits etc. in accordance with these instructions, taking into account the working conditions and the work to be performed.** Use of the power tool for operations different from those intended could result in a hazardous situation.

Service

- ▶ **Have your power tool serviced by a qualified repair person using only identical replacement parts.** This will ensure that the safety of the power tool is maintained.

Safety Warnings for Circular Saws

Cutting procedures

- ▶ **DANGER: Keep hands away from cutting area and the blade. Keep your second hand on auxiliary handle, or motor housing.** If both hands are holding the saw, they cannot be cut by the blade.
- ▶ **Do not reach underneath the workpiece.** The guard cannot protect you from the blade below the workpiece.
- ▶ **Adjust the cutting depth to the thickness of the workpiece.** Less than a full tooth of the blade teeth should be visible below the workpiece.
- ▶ **Never hold piece being cut in your hands or across your leg. Secure the workpiece to a stable platform.** It is important to support the work properly to minimize body exposure, blade binding, or loss of control.
- ▶ **Hold the power tool by insulated gripping surfaces only, when performing an operation where the cutting tool may contact hidden wiring or its own cord.** Contact with a "live" wire will also make exposed metal parts of the power tool "live" and could give the operator an electric shock.
- ▶ **When ripping, always use a rip fence or straight edge guide.** This improves the accuracy of cut and reduces the chance of blade binding.
- ▶ **Always use blades with correct size and shape (diamond versus round) of arbour holes.** Blades that do not match the mounting hardware of the saw will run eccentrically, causing loss of control.
- ▶ **Never use damaged or incorrect blade washers or bolt.** The blade washers and bolt were specially designed for your saw, for optimum performance and safety of operation.
- ▶ **Kickback causes and related warnings**
 - Kickback is a sudden reaction to a pinched, bound or misaligned saw blade, causing an uncontrolled saw to lift up and out of the workpiece toward the operator;

– When the blade is pinched or bound tightly by the kerf closing down, the blade stalls and the motor reaction drives the unit rapidly back toward the operator;
 – If the blade becomes twisted or misaligned in the cut, the teeth at the back edge of the blade can dig into the top surface of the wood causing the blade to climb out of the kerf and jump back toward the operator.
 Kickback is the result of saw misuse and/or incorrect operating procedures or conditions and can be avoided by taking proper precautions as given below.

- ▶ **Maintain a firm grip with both hands on the saw and position your arms to resist kickback forces. Position your body to either side of the blade, but not in line with the blade.** Kickback could cause the saw to jump backwards, but kickback forces can be controlled by the operator, if proper precautions are taken.
- ▶ **When blade is binding, or when interrupting a cut for any reason, release the trigger and hold the saw motionless in the material until the blade comes to a complete stop. Never attempt to remove the saw from the work or pull the saw backward while the blade is in motion or kickback may occur.** Investigate and take corrective actions to eliminate the cause of blade binding.
- ▶ **When restarting a saw in the workpiece, centre the saw blade in the kerf and check that saw teeth are not engaged into the material.** If saw blade is binding, it may walk up or kickback from the workpiece as the saw is restarted.
- ▶ **Support large panels to minimise the risk of blade pinching and kickback.** Large panels tend to sag under their own weight. Supports must be placed under the panel on both sides, near the line of cut and near the edge of the panel.
- ▶ **Do not use dull or damaged blades.** Unsharpened or improperly set blades produce narrow kerf causing excessive friction, blade binding and kickback.
- ▶ **Blade depth and bevel adjusting locking levers must be tight and secure before making cut.** If blade adjustment shifts while cutting, it may cause binding and kickback.
- ▶ **Use extra caution when sawing into existing walls or other blind areas.** The protruding blade may cut objects that can cause kickback.

Lower guard function

- ▶ **Check lower guard for proper closing before each use. Do not operate the saw if lower guard does not move freely and close instantly. Never clamp or tie the lower guard into the open position.** If saw is accidentally dropped, lower guard may be bent. Raise the lower guard with the retracting handle and make sure it moves freely and does not touch the blade or any other part, in all angles and depths of cut.
- ▶ **Check the operation of the lower guard spring. If the guard and the spring are not operating properly, they must be serviced before use.** Lower guard may operate sluggishly due to damaged parts, gummy deposits, or a build-up of debris.

- ▶ **The lower guard may be retracted manually only for special cuts such as “plunge cuts and angle cuts”. Raise the lower guard by retracting the handle and as soon as the blade enters the material, release the lower guard.** For all other sawing operations, the lower guard should operate automatically.
- ▶ **Always observe that the lower guard is covering the blade before placing saw down on bench or floor.** An unprotected, coasting blade will cause the saw to walk backwards, cutting whatever is in its path. Be aware of the time it takes for the blade to stop after switch is released.

Additional safety warnings

- ▶ **Do not reach into the chip ejector with your hands.** They could be injured by rotating parts.
- ▶ **Do not work overhead with the saw.** In this manner you do not have sufficient control over the power tool.
- ▶ **Use suitable detectors to determine if utility lines are hidden in the work area or call the local utility company for assistance.** Contact with electric lines can lead to fire and electric shock. Damaging a gas line can lead to explosion. Penetrating a water line causes property damage or may cause an electric shock.
- ▶ **Do not operate the power tool stationary.** It is not designed for operation with a saw table.
- ▶ **Do not use high speed steel (HSS) saw blades.** Such saw blades can easily break.
- ▶ **Do not saw ferrous metals.** Red hot chips can ignite the dust extraction.
- ▶ **When working with the machine, always hold it firmly with both hands and provide for a secure stance.** The power tool is guided more secure with both hands.
- ▶ **Secure the workpiece.** A workpiece clamped with clamping devices or in a vice is held more secure than by hand.
- ▶ **Always wait until the machine has come to a complete stop before placing it down.** The tool insert can jam and lead to loss of control over the power tool.

Products sold in GB only: Your product is fitted with a BS 1363/A approved electric plug with internal fuse (ASTA approved to BS 1362).

If the plug is not suitable for your socket outlets, it should be cut off and an appropriate plug fitted in its place by an authorised customer service agent. The replacement plug should have the same fuse rating as the original plug. The severed plug must be disposed of to avoid a possible shock hazard and should never be inserted into a mains socket elsewhere.

Products sold in AUS and NZ only: Use a residual current device (RCD) with a rated residual current of 30 mA or less.

Product Description and Specifications



Read all safety warnings and all instructions. Failure to follow the warnings and instructions may result in electric shock, fire and/or serious injury.

While reading the operating instructions, unfold the graphics page for the machine and leave it open.

Intended Use

The machine is intended for lengthways and crossways cutting of wood with straight cutting lines as well as mitre cuts in wood while resting firmly on the workpiece. With suitable saw blades, thin-walled non-ferrous metals, e. g., profiles, can also be sawed.

Working ferrous metals is not permitted.

Product Features

The numbering of the product features refers to the illustration of the machine on the graphics page.

- 1 On/Off switch
- 2 Lock-off button for On/Off switch
- 3 Auxiliary handle (insulated gripping surface)
- 4 Spindle lock button
- 5 Scale for mitre angle

- 6 Wing bolt for bevel-angle preselection
- 7 Wing bolt for parallel guide
- 8 Cutting mark, 45°
- 9 Cutting mark, 0°
- 10 Parallel guide
- 11 Retracting blade guard
- 12 Base plate
- 13 Lever for retracting blade guard
- 14 Chip ejector
- 15 Blade guard
- 16 Handle (insulated gripping surface)
- 17 Hex key
- 18 Clamping bolt with washer
- 19 Clamping flange
- 20 Saw blade*
- 21 Mounting flange
- 22 Saw spindle
- 23 Extraction adapter*
- 24 Clamping lever for cutting-depth preselection
- 25 Cutting-depth scale
- 26 Wing bolt for bevel-angle preselection
- 27 Set of screw clamps**

*Accessories shown or described are not part of the standard delivery scope of the product. A complete overview of accessories can be found in our accessories program.

**Commercially available (not included in the delivery scope)

Technical Data

Circular Saw		GKS 190	GKS 190
Article number		3 601 F23 0.0	3 601 F23 0.1
Rated power input	W	1400	1400
No-load speed	min ⁻¹	5500	5500
Cutting depth, max.			
– for 0° bevel angle	mm	70	67
– for 45° bevel angle	mm	50	49
Spindle lock		●	●
Base plate dimensions	mm	302 x 140	302 x 140
Saw blade diameter, max.	mm	190	184
Saw blade diameter, min.	mm	184	184
Blade thickness, max.	mm	2.0	2.5
Mounting bore	mm	30	16
Weight according to EPTA-Procedure 01:2014	kg	4.2	4.2
Protection class		□ / II	□ / II

The values given are valid for a nominal voltage [U] of 230 V. For different voltages and models for specific countries, these values can vary.

Noise/Vibration Information

Sound emission values determined according to EN 60745-2-5.

Typically the A-weighted noise levels of the product are: Sound pressure level 96 dB(A); Sound power level 107 dB(A). Uncertainty K = 3 dB.

Wear hearing protection!

Vibration total values a_h (tri-ax vector sum) and uncertainty K determined according to EN 60745-2-5:
 $a_h < 2.5 \text{ m/s}^2$, $K = 1.5 \text{ m/s}^2$.

The vibration level given in this information sheet has been measured in accordance with a standardised test given in EN 60745 and may be used to compare one tool with another. It may be used for a preliminary assessment of exposure.

The declared vibration emission level represents the main applications of the tool. However if the tool is used for different applications, with different accessories or insertion tools or is poorly maintained, the vibration emission may differ. This may significantly increase the exposure level over the total working period.

An estimation of the level of exposure to vibration should also take into account the times when the tool is switched off or when it is running but not actually doing the job. This may significantly reduce the exposure level over the total working period. Identify additional safety measures to protect the operator from the effects of vibration such as: maintain the tool and the accessories, keep the hands warm, organisation of work patterns.

Declaration of Conformity

We declare under our sole responsibility that the product described under "Technical Data" is in conformity with all relevant provisions of the directives 2011/65/EU, until 19 April 2016: 2004/108/EC, from 20 April 2016 on: 2014/30/EU, 2006/42/EC including their amendments and complies with the following standards: EN 60745-1, EN 60745-2-5, EN 50581.

Technical file (2006/42/EC) at:

Robert Bosch Power Tools GmbH, PT/ETM9,
70538 Stuttgart, GERMANY

Henk Becker
Executive Vice President
Engineering

Helmut Heinzelmann
Head of Product Certification
PT/ETM9

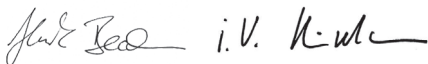

Robert Bosch Power Tools GmbH
70538 Stuttgart, GERMANY
Stuttgart, 01.01.2017

Assembly

Mounting/Replacing the Saw Blade

- ▶ **Before any work on the machine itself, pull the mains plug.**
- ▶ **When mounting the saw blade, wear protective gloves.**
Danger of injury when touching the saw blade.
- ▶ **Only use saw blades that correspond with the characteristic data given in the operating instructions.**
- ▶ **Do not under any circumstances use grinding discs as the cutting tool.**

Selecting a Saw Blade

An overview of recommended saw blades can be found at the end of this manual.

Removal of the Saw Blade (see figure A)

For changing the cutting tool, it is best to place the machine on the face side of the motor housing.

- Press the spindle lock button **4** and keep it pressed.

▶ **The spindle lock button 4 may be actuated only when the saw spindle is at a standstill.** Otherwise, the power tool can be damaged.

- With the Hex key **17**, unscrew the clamping bolt **18** turning in rotation direction **⌚**.
- Tilt back the retracting blade guard **11** and hold firmly.
- Remove the clamping flange **19** and the saw blade **20** from the saw spindle **22**.

Mounting the Saw Blade (see figure A)

For changing the cutting tool, it is best to place the machine on the face side of the motor housing.

- Clean the saw blade **20** and all clamping parts to be assembled.
- Tilt back the retracting blade guard **11** and hold firmly.
- Place the saw blade **20** on to the mounting flange **21**. The cutting direction of the teeth (direction or arrow on saw blade) and the direction-of-rotation arrow on the blade guard **15** must correspond.
- Mount the clamping flange **19** and screw in the clamping bolt **18** turning in rotation direction **⌚**. Observe correct mounting position of mounting flange **21** and clamping flange **19**.
- Press the spindle lock button **4** and keep it pressed.
- With the Hex key **17**, tighten the clamping bolt **18** turning in rotation direction **⌚**. The tightening torque is between 6–9 Nm, which corresponds to hand tight plus ¼ turn.

Dust/Chip Extraction

▶ **Before any work on the machine itself, pull the mains plug.**

▶ Dusts from materials such as lead-containing coatings, some wood types, minerals and metal can be harmful to one's health. Touching or breathing-in the dusts can cause allergic reactions and/or lead to respiratory infections of the user or bystanders.

Certain dusts, such as oak or beech dust, are considered as carcinogenic, especially in connection with wood-treatment additives (chromate, wood preservative). Materials containing asbestos may only be worked by specialists.

- As far as possible, use a dust extraction system suitable for the material.
- Provide for good ventilation of the working place.
- It is recommended to wear a P2 filter-class respirator.

Observe the relevant regulations in your country for the materials to be worked.

▶ **Prevent dust accumulation at the workplace.** Dusts can easily ignite.

Mounting the Extraction Adapter (see figure B)

Attach the extraction adapter **23** onto the chip ejector **14** until it latches. A vacuum hose with a diameter of 35 mm can be connected to the extraction adapter **23**.

- ▶ **The extraction adapter may not be mounted when no external dust extraction is connected.** Otherwise the extraction channel can become clogged.
- ▶ **Do not connect a dust bag to the extraction adapter.** Otherwise the extraction system can become clogged.

To ensure optimum extraction, the extraction adapter **23** must be cleaned regularly.

External Dust Extraction

Connect the vacuum hose to a vacuum cleaner (accessory). An overview for connecting to various vacuum cleaners can be found at the end of this manual.

The machine can be plugged directly into the receptacle of a Bosch all-purpose vacuum cleaner with remote starting control. The vacuum cleaner starts automatically when the machine is switched on.

The vacuum cleaner must be suitable for the material being worked.

When vacuuming dry dust that is especially detrimental to health or carcinogenic, use a special vacuum cleaner.

Operation

Operating Modes

► **Before any work on the machine itself, pull the mains plug.**

Adjusting the Cutting Depth (see figure C)

► **Adjust the cutting depth to the thickness of the workpiece.** Less than a full tooth of the blade teeth should be visible below the workpiece.

Loosen the clamping lever **24**. For a smaller cutting depth, pull the saw away from the base plate **12**; for a larger cutting depth, push the saw toward the base plate **12**. Adjust the desired cutting depth at the cutting-depth scale. Tighten the clamping lever **24** again.

If the cutting depth cannot be fully adjusted after loosening clamping lever **24**, pull clamping lever **24** away from the saw and swivel it downward. Release the clamping lever **24** again. Repeat this procedure until the requested cutting depth can be adjusted.

If the cutting depth cannot be sufficiently locked after tightening clamping lever **24**, pull clamping lever **24** away from the saw and swivel it upward. Release the clamping lever **24** again. Repeat this procedure until the cutting depth is locked.

Adjusting the Cutting Angle

Loosen the wing bolts **6** and **26**. Tilt the saw sideways. Adjust the desired measure on the scale **5**. Tighten the wing bolts **6** and **26** again.

Note: For bevel cuts, the cutting depth is smaller than the setting indicated on the cutting-depth scale **25**.

Cutting Marks

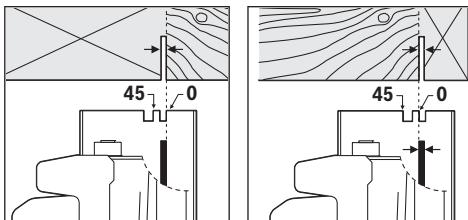

The 0° cutting mark **9** indicates the position of the saw blade for right-angled cuts. The 45° cutting mark **8** indicates the position of the saw blade for 45° cuts.

For precise cuts, position the circular saw against the workpiece as shown in the figure. It is best to carry out a trial cut.

Starting Operation

► **Observe correct mains voltage! The voltage of the power source must agree with the voltage specified on the nameplate of the machine. Power tools marked with 230 V can also be operated with 220 V.**

Switching On and Off

To **start** the machine, **first** push the lock-off button for the On/Off switch **2** and **then** press the On/Off switch **1** and keep it pressed.

To **switch off** the machine, release the On/Off switch **1**.

Note: For safety reasons, the On/Off switch **1** cannot be locked; it must remain pressed during the entire operation.

To save energy, only switch the power tool on when using it.

Working Advice

Protect saw blades against impact and shock.

Guide the machine evenly and with light feed in the cutting direction. Excessive feed significantly reduces the service life of the saw blade and can cause damage to the power tool.

Sawing performance and cutting quality depend essentially on the condition and the tooth form of the saw blade. Therefore, use only sharp saw blades that are suited for the material to be worked.

► **Before any work on the machine itself, pull the mains plug.**

Sawing Wood

The correct selection of the saw blade depends on the type and quality of the wood and whether lengthway or crossway cuts are required.

When cutting spruce lengthways, long spiral chips are formed.

Beech and oak dusts are especially detrimental to health. Therefore, work only with dust extraction.

Sawing with Parallel Guide (see figure D)

The parallel guide **10** enables exact cuts along a workpiece edge and cutting strips of the same dimension.

Loosen wing bolt **7** and slide the scale of the parallel guide **10** through the guide in the base plate **12**. Adjust the desired cutting width as the scale setting at the respective cutting mark **9** or **8**; see Section "Cutting Marks". Tighten wing bolt **7** again.

Sawing with Auxiliary Guide (see figure E)

For sawing large workpieces or straight edges, a board or strip can be clamped to the workpiece as an auxiliary guide; the base plate of the circular saw can be guided alongside the auxiliary guide.

Maintenance and Service

Maintenance and Cleaning

- ▶ **Before any work on the machine itself, pull the mains plug.**
- ▶ **For safe and proper working, always keep the machine and ventilation slots clean.**

The retracting blade guard must always be able to move freely and retract automatically. Therefore, always keep the area around the retracting blade guard clean. Remove dust and chips by blowing out with compressed air or with a brush.

Saw blades that are not coated can be protected against corrosion with a thin coat of acid-free oil. Before use, the oil must be removed again, otherwise the wood will become soiled.

Resin and glue residue on the saw blade produces poor cuts. Therefore, clean the saw blade immediately after use.

If the replacement of the supply cord is necessary, this has to be done by Bosch or an authorized Bosch service agent in order to avoid a safety hazard.

After-sales Service and Application Service

In all correspondence and spare parts order, please always include the 10-digit article number given on the type plate of the machine.

Our after-sales service responds to your questions concerning maintenance and repair of your product as well as spare parts. Exploded views and information on spare parts can also be found under:

www.bosch-pt.com

Bosch's application service team will gladly answer questions concerning our products and their accessories.

Great Britain

Robert Bosch Ltd. (B.S.C.)

P.O. Box 98

Broadwater Park

North Orbital Road

Denham

Uxbridge

UB 9 5HJ

At www.bosch-pt.com.uk you can order spare parts or arrange the collection of a product in need of servicing or repair.

Tel. Service: (0344) 7360109

E-Mail: boschservicecentre@bosch.com

Ireland

Origo Ltd.

Unit 23 Magna Drive

Magna Business Park

City West

Dublin 24

Tel. Service: (01) 4666700

Fax: (01) 4666888

Australia, New Zealand and Pacific Islands

Robert Bosch Australia Pty. Ltd.

Power Tools

Locked Bag 66

Clayton South VIC 3169

Customer Contact Center

Inside Australia:

Phone: (01300) 307044

Fax: (01300) 307045

Inside New Zealand:

Phone: (0800) 543353

Fax: (0800) 428570

Outside AU and NZ:

Phone: +61 3 95415555

www.bosch.com.au

Republic of South Africa

Customer service

Hotline: (011) 6519600

Gauteng – BSC Service Centre

35 Roper Street, New Centre

Johannesburg

Tel.: (011) 4939375

Fax: (011) 4930126

E-Mail: bsctools@icon.co.za

KZN – BSC Service Centre

Unit E, Almar Centre

143 Crompton Street

Pinetown

Tel.: (031) 7012120

Fax: (031) 7012446

E-Mail: bsc.dur@za.bosch.com

Western Cape – BSC Service Centre

Democracy Way, Prosperity Park

Milnerton

Tel.: (021) 5512577

Fax: (021) 5513223

E-Mail: bsc@zsd.co.za

Bosch Headquarters

Midrand, Gauteng

Tel.: (011) 6519600

Fax: (011) 6519880

E-Mail: rbsa-hq.pts@za.bosch.com

Disposal

The machine, accessories and packaging should be sorted for environmental-friendly recycling.

Do not dispose of power tools into household waste!

Only for EC countries:



According to the European Directive 2012/19/EU for Waste Electrical and Electronic Equipment and its implementation into national right, power tools that are no longer usable must be collected separately and disposed of in an environmentally correct manner.

Subject to change without notice.

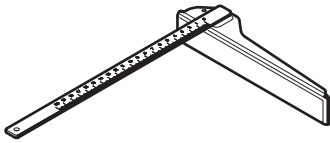

1 608 190 007

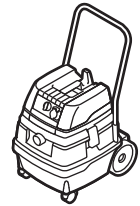
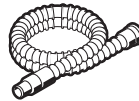
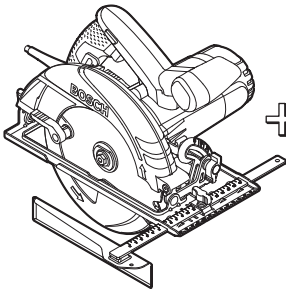

1 619 P06 204

Ø 35 mm
 3 m 2 609 390 392
 5 m 2 609 390 393

GAS 25
 GAS 50
 GAS 50 M

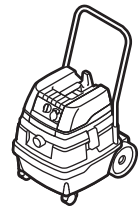
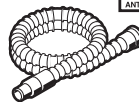
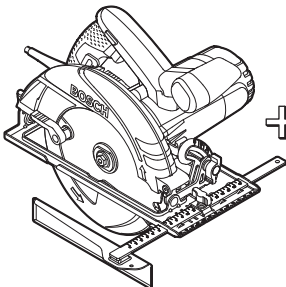

1 619 P06 204

Ø 35 mm
 3 m 2 607 002 163
 5 m 2 607 002 164

GAS 25
 GAS 50
 GAS 50 M



optiline
WOOD

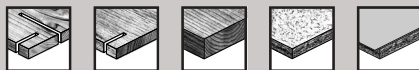

speedline
WOOD

fast
CUT

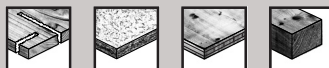

MULTI
MATERIAL



CONSTRUCT
WOOD

fast
CUT

