



DRAPER[®]

STORM FORCE

230V GASLESS MIG WELDER

63669



These instructions accompanying the product are the original instructions. This document is part of the product, keep it for the life of the product passing it on to any subsequent holder of the product. Read all these instructions before assembling, operating or maintaining this product.

This manual has been compiled by Draper Tools describing the purpose for which the product has been designed, and contains all the necessary information to ensure its correct and safe use. By following all the general safety instructions contained in this manual, it will ensure both product and operator safety, together with longer life of the product itself.

All photographs and drawings in this manual are supplied by Draper Tools to help illustrate the operation of the product.

Whilst every effort has been made to ensure the accuracy of information contained in this manual, the Draper Tools policy of continuous improvement determines the right to make modifications without prior warning.

1. TITLE PAGE

1.1 INTRODUCTION:

USER MANUAL FOR: 230V Gasless MIG Welder

Stock No: 63669

Part No: MIG100

1.2 REVISIONS:

Date first published November 2016.

Date of first revision: September 2020.

As our user manuals are continually updated, users should make sure that they use the very latest version.

Downloads are available from: <http://drapertools.com/manuals>

Draper Tools Limited
Hursley Road
Chandler's Ford
Eastleigh
Hampshire
SO53 1YF
UK

Website: drapertools.com

Product Help Line: +44 (0) 23 8049 4344

General Fax: +44 (0) 23 8026 0784

1.3 UNDERSTANDING THIS MANUALS SAFETY CONTENT:

Warning! – Information that draws attention to the risk of injury or death.

Important – Information that draws attention to the risk of damage to the product or surroundings.

1.4 COPYRIGHT © NOTICE:

Copyright © Draper Tools Limited.

Permission is granted to reproduce this publication for personal and educational use only.

Commercial copying, redistribution, hiring or lending is prohibited.

No part of this publication may be stored in a retrieval system or transmitted in any other form or means without written permission from Draper Tools Limited.

In all cases this copyright notice must remain intact.

2. CONTENTS

2.1 TABLE OF CONTENTS

1. TITLE PAGE	
1.1 INTRODUCTION:.....	2
1.2 REVISIONS:.....	2
1.3 UNDERSTANDING THIS MANUALS SAFETY CONTENT:.....	2
1.4 COPYRIGHT © NOTICE:.....	2
2. CONTENTS	
2.1 TABLE OF CONTENTS	3
3. WARRANTY	
3.1 WARRANTY.....	4
4. INTRODUCTION	
4.1 SCOPE.....	5
4.2 SPECIFICATION.....	5
4.3 HANDLING AND STORAGE.....	5
5. HEALTH AND SAFETY INFORMATION	
5.1 GENERAL SAFETY INSTRUCTIONS FOR POWER TOOL USE	6
5.2 ADDITIONAL SAFETY INSTRUCTIONS FOR WELDING	7
5.3 RESIDUAL RISK.....	9
5.4 CONNECTION TO THE POWER SUPPLY.....	9
6. TECHNICAL DESCRIPTION	
6.1 IDENTIFICATION.....	11
7. UNPACKING AND CHECKING	
7.1 PACKAGING	12
7.2 WHAT'S IN THE BOX	12
8. PREPARING THE COMPRESSOR	
8.1 LOCATION	13
8.2 INSTALLING THE FLUX CORED FILLER WIRE.....	13
8.3 NO GAS WELDING PRINCIPLE	14
9. OPERATION	
9.1 ON/OFF SWITCH	15
9.2 WELDING CURRENT REGULATION SWITCHES.....	15
9.3 WIRE SPEED ADJUSTMENT.....	15
9.4 THERMAL CUT OUT	15
9.5 MIG WELDING PRINCIPLES	16
10. TROUBLESHOOTING	
10.1 TROUBLESHOOTING GUIDE.....	17
11. MAINTENANCE	
11.1 MAINTENANCE.....	18
12. EXPLANATION OF SYMBOLS	
12.1 EXPLANATION OF SYMBOLS.....	19
12. DISPOSAL	
12.1 DISPOSAL.....	20

3. WARRANTY

3.1 WARRANTY

Draper tools have been carefully tested and inspected before shipment and are guaranteed to be free from defective materials and workmanship.

Should the tool develop a fault, please return the complete tool to your nearest distributor or contact:

Draper Tools Limited, Chandler's Ford, Eastleigh, Hampshire, SO53 1YF. England.

Telephone Sales Desk: +44 (0) 8049 4333 or Product Help Line +44 (0) 23 8049 4344.

A proof of purchase **must** be provided with the tool.

If upon inspection it is found that the fault occurring is due to defective materials or workmanship, repairs will be carried out free of charge. This warranty period covering labour is 12 months from the date of purchase except where tools are hired out when the warranty period is 90 days from the date of purchase. The warranty is extended to 24 months for parts only. This warranty does not apply to any consumable parts, any type of battery or normal wear and tear, nor does it cover any damage caused by misuse, careless or unsafe handling, alterations, accidents, or repairs attempted or made by any personnel other than the authorised Draper warranty repair agent.

Note: If the tool is found not to be within the terms of warranty, repairs and carriage charges will be quoted and made accordingly.

This warranty applies in lieu of any other warranty expressed or implied and variations of its terms are not authorised.

Your Draper warranty is not effective unless you can produce upon request a dated receipt or invoice to verify your proof of purchase within the warranty period.

Please note that this warranty is an additional benefit and does not affect your statutory rights.

Draper Tools Limited.

4. INTRODUCTION

4.1 SCOPE

This MIG welder is a limited duty machine designed to perform welding fabrication on a variety of steel types with flux cored filler wire.

This product is intended for domestic and infrequent light trade use only. Any application other than that it was intended for, is considered misuse.

This product is not a toy and must not be used by children or any person with reduced physical, sensory or mental capabilities or lack of experience and knowledge, or people unfamiliar with these instructions.

Local regulations may restrict the age of the operator.

4.2 SPECIFICATION

Stock No.....	63669
Part No.	MIG100
Input: Voltage (U1..V).....	230V~
Phase	1
Frequency	50Hz
Rated maximum Supply current (I1eff).....	5A
Capacity	3000W
Output:	
No-load voltage (U0..V)	28V
Welding current	
range (..A to ..A)	40A to 100A
Duty factor	
10%	100A
60%	40A
Protection fuse	13A
Suitable welding wire (mm)	0.6-0.9mm
Torch coupling	Direct
Insulation class	H
Cooling Device	Fan
Max. working Temperature	40°C
Dimensions.....	340× 345× 190mm
Weight (gross)	14.5kg

4.3 HANDLING AND STORAGE

- Care must still be taken when handling and lifting. Dropping this machine will have an effect on its operation and may also result in personal injury. This machine is not a toy and must be respected.
- The environment will have a negative result on its operation if you are not careful. If the machine is unprotected from dust and debris; components will become clogged: And if not cleaned and maintained correctly or regularly the machine will not perform at its best.

5. HEALTH AND SAFETY INFORMATION

5.1 GENERAL SAFETY INSTRUCTIONS FOR POWER TOOL USE

When using any type of power tool there are steps that should be taken to make sure that you, as the user, remain safe.

Common sense and a respect for the tool will help reduce the risk of injury.

Read the instruction manual fully. Do not attempt any operation until you have read and understood this manual.

Most important you must know how to safely start and stop this machine, especially in an emergency.

Keep the work area tidy and clean. Attempting to clear clutter from around the machine during use will reduce your concentration. Mess on the floor creates a trip hazard. Any liquid spilt on the floor could result in you slipping.

Find a suitable location. If the machine is bench mounted, the location should provide good natural light or artificial lighting as a replacement. Avoid damp and dust locations as it will have a negative effect on the machine's performance. If the machine is portable do not expose the tool to rain. In all cases do not operate power tools near any flammable materials.

Keep bystanders away. Children, onlookers and passers by must be restricted from entering the work area for their own protection. The barrier must extend a suitable distance from the tool user.

Unplug and house all power tools that are not in use. A power tool should never be left unattended while connected to the power supply. They must be housed in a suitable location, away locked up and from children. This includes battery chargers.

Do not overload or misuse the tool. All tools are designed for a purpose and are limited to what they are capable of doing. Do not attempt to use a power tool (or adapt it in any way) for an application it is not designed for. Select a tool appropriate for the size of the job. Overloading a tool will result in tool failure and user injury. This covers the use of accessories.

Dress properly. Loose clothing, long hair and jewellery are all dangerous because they can become entangled in moving machinery. This can also result in parts of body being pulled into the machine. Clothing should be close fitted, with any long hair tied back and jewellery and neck ties removed. Footwear must be fully enclosed and have a non-slip sole.

Wear personal protective equipment (PPE). Dust, noise, vibration and swarf can all be dangerous if not suitably protected against. If the work involving the power tool creates dust or fumes wear a dust mask. Vibration to the hand, caused by operating some tools for longer periods must be protected against. Wear vibration reducing gloves and allow long breaks between uses. Protect against dust and swarf by wearing approved safety goggles or a face shield. These are some of the more common hazards and preventions, however, always find out what hazards are associated with the machine/work process and wear the most suitable protective equipment available.

Do not breathe contaminated air. If the work creates dust or fumes connect the machine (if possible) to an extraction system either locally or remotely. Working outdoors can also help if possible.

Move the machine as instructed. If the machine is hand held, do not carry it by the power supply cable. If the product is heavy, employ a second or third person to help move it safely or use a mechanical device. Always refer to the instructions for the correct method.

Do not overreach. Extending your body too far can result in a loss of balance and you falling. This could be from a height or onto a machine and will result in injury.

Maintain your tools correctly. A well maintained tool will do the job safely. Replace any damaged or missing parts immediately with original parts from the manufacturer. As applicable, keep blades sharp, moving parts clean, oiled or greased, handles clean, and emergency devices working.

Wait for the machine to stop. Unless the machine is fitted with a safety brake, some parts may continue to move due to momentum. Wait for all parts to stop, then unplug it from the power supply

5. HEALTH AND SAFETY INFORMATION

before making any adjustments, carrying out maintenance operations or just finishing using the tool.

Remove and check setting tools. Some machinery requires the use of additional tools or keys to set, load or adjust the power tool. Before starting the power tool always check to make certain they have been removed and are safely away from the machine.

Prevent unintentional starting. Before plugging any machine in to the power supply, make sure the switch is in the OFF position. If the machine is portable, do not hold the machine near the switch and take care when putting the machine down, that nothing can operate the switch.

Carefully select an extension lead. Some machines are not suitable for use with extension leads. If the tool is designed for use outdoors, use an extension lead also suitable for that environment. When using an extended lead, select one capable of handling the current (amps) drawn by the machine in use. Fully extend the lead regardless of the distance between the power supply and the tool. Excess current (amps) and a coiled extension lead will both cause the cable to heat up and can result in fire.

Concentrate and stay alert. Distractions are likely to cause an accident. Never operate a power tool if you are under the influence of drugs (prescription or otherwise), including alcohol or if you are feeling tired. Being disorientated will result in an accident.

Have this tool repaired by a qualified person. This tool is designed to conform to the relevant international and local standards and as such should be maintained and repaired by someone qualified, using only original parts supplied by the manufacturer. This will ensure the tool remains safe to use.

5.2 ADDITIONAL SAFETY INSTRUCTIONS FOR WELDING

WARNING: When using electric tools basic safety precautions should always be followed to reduce the risk of fire, electric shock and personal injury including the following.

Read all these instructions before attempting to operate this product and save these instructions.

Electric shock can kill:

- Remove the plug from the socket before carrying out adjustment, servicing or maintenance.
- Allow 5 minutes waiting time for the capacitors to discharge before removing the panels for any maintenance operations
- Do not touch live electrical parts.
- Never use electrode holders or cables with damaged or deteriorated insulation.
- Keep working environment, equipment, cables and clothing free from grease, oil, moisture and dirt.
- Ensure welding machine has been correctly earthed and all panels are fitted securely.
- The operator must be insulated from the floor and work bench using a dry insulation mat.
- Wear isolating footwear and gloves that are in good condition, i.e. without holes.
- In hazardous conditions of increased electric shock always ensure a second person is present in case of accident.
- Never change electrodes with bare hands or damp gloves.
- Keep welding cables away from power cables.
- Regularly inspect the condition of the welding, earth, and power cables for signs of damage.
- Do not leave machine unattended and remove plug from socket when not in use.
- Do not use welding cables unsuitable for the amperage.
- Ensure earth clamp is adjacent to weld seam, secured to bare metal and when not in use is insulated for safety.
- Keep all equipment well maintained.

5. HEALTH AND SAFETY INFORMATION

- The operator shall prevent gas cylinders in the vicinity of the work piece from becoming part of the welding circuit.

Fumes & gases can be harmful:

- The welding process generates hazardous fumes as a by-product. Inhalation of these fumes is hazardous to health.
- Keep your head away from the weld to avoid breathing the fumes.
- If welding in confined spaces ensure adequate ventilation and use a fume extractor.
- Welding fumes displace oxygen. Danger of suffocation.
- By-products of welding can react with other chemical vapours to produce a toxic/explosive environment.

Welding can cause fire or explosion:

- Arc welding and allied processes can cause fire and explosions and precautions shall be taken to prevent these hazards.
- Before starting a weld ensure the area is clear of flammable materials.
- Remove any inflammables to a safe distance, especially substances likely to generate a dangerous vapour.
- The welding arc can cause serious burns. Avoid contact with skin.
- Sparks and molten metal are cast out during welding. Take precautions to prevent fire igniting and wear protective clothing.
- Sparks and molten metal can pass through gaps. Be aware that fire can start out of sight. Flammables in a locked cabinet may not be safe.
- Do not weld pressurised containers.
- Do not weld tanks, drums or other vessels until they have been correctly cleaned/prepared for welding.
- Always have appropriate and fully maintained fire fighting equipment suitable for the materials used and for use in electrical environments available in close proximity at all times.
- Keep clothing free from oil and grease.
- Wear hat, flame-proof apron, woollen clothing, gloves, long sleeve tops with closed neck, trousers (without turn-ups) to cover non-slip boots.
- Protective head and shoulder coverings should be worn when overhead welding.
- Avoid taking any fuels with you e.g. cigarette lighters or matches.
- Hot spots and their immediate surroundings should be observed until their temperature has dropped to normal.

Personal Protection:

- The body should be protected by suitable clothing.
- The use of neck protection may be necessary against reflected radiation.
- Wear safety glasses when chipping, wire brushing, grinding or when near cooling welds as metal filings or slag can be thrown up. Fully enclosed goggles are advisable.
- Arc machines generate a magnetic field which is detrimental to pacemaker recipients. Consult your doctor before going near welding equipment/operations.
- The UV and IR radiation generated by welding is highly damaging to the eye, causing burns. This can also affect the skin. Protect the eyes and face.
- The face and eyes shall be protected by suitable welding shields equipped with appropriate ocular protection filters.
- Where environments are subject to pedestrians and traffic ensure a protective screen is used to avoid accidental arc glare.

5. HEALTH AND SAFETY INFORMATION

- Do not weld in the vicinity of children or animals and ensure no one is looking before striking up.
- In the welding environment, damaging levels of noise can exist. Wear hearing protection if the process dictates.
- Do not touch hot equipment or metal. Allow the weld time to cool, use the correct tool and wear protective welding gauntlets.
- Wear flame retardant clothing (leather, wool, etc.).
- Take care when adjusting or maintaining the torch that it has had time to cool sufficiently and is disconnected.
- The arc generates
 - ultra-violet radiation (can damage skin and eyes);
 - visible light (can dazzle eyes and impair vision);
 - infra-red (heat) radiation (can damage skin and eyes);
- Such radiation can be direct or reflected from surfaces such as bright metals and light coloured objects.

Limitations:

- Do not use for;
 - operations in severe conditions (e.g. extreme climates, freezer applications, strong magnetic fields etc).
 - operations subject to special rules (e.g. potentially explosive atmospheres, mines etc).
 - operations that require ingress protection greater than IPX0, e.g. in rain or snow etc.

General:

- Training should be sought out in
 - the safe use of this equipment;
 - the processes;
 - the emergency procedures;
- Welding power sources are not to be used for pipe thawing.
- Take precautions against toppling over, if the power source shall be placed on a tilted plane.
- All equipment should be kept in good working condition, inspected and, when defective, promptly repaired or withdrawn from service - All equipment should be placed so that it does not present a hazard in passageways, on ladders or stairways, and should be operated in accordance with the manufacturer's instructions.
- In the vicinity of an arc, non-reflective curtains or screens shall be used to isolate persons from the arc radiation. A warning, e.g. a symbol for eye protection, should refer to the hazard of arc radiation.

5.3 RESIDUAL RISK

Important: Although the safety instructions and operating manuals for our tools contain extensive instructions of safe working with power tools, every power tool involves a certain residual risk which can not be completely excluded by safety mechanisms. Power tools must therefore always be operated with caution!

5.4 CONNECTION TO THE POWER SUPPLY

Caution: Risk of electric shock. Do not open.

This appliance is supplied with an approved plug and cable for your safety. The value of the fuse fitted is marked on the pin face of the plug. Should the fuse need replacing, ensure the substitute is of the correct rating, approved to BS1362 and ASTA or BS Kite marked.

5. HEALTH AND SAFETY INFORMATION

ASTA 

BSI 

Make sure the power supply information on the machine's rating plate are compatible with the power supply you intend to connect it to.

If a replacement plug is to be fitted this must be carried out by a qualified electrician.





The damaged or incomplete plug, when cut from the cable shall be disabled to prevent connection to a live electrical outlet.

This appliance is Class I[†] and is designed for connection to a power supply matching that detailed on the rating label and compatible with the plug fitted.

If an extension lead is required, use an approved and compatible lead rated for this appliance. Follow all the instruction supplied with the extension lead.

[†]Earthed:  This product requires an earth connection to protect against electric shock from accessible conductive parts in the event of a failure of the basic insulation.

Important: If using an extension lead, follow the instructions that came with your lead regarding maximum load while cable is wound. If in doubt, ensure that the entire cable is unwound. Using a coiled extension lead will generate heat which could melt the lead and cause a fire.

MIG100		NO:	
		IEC 60974-1	
		40A/16.1V-100A/19V	
	U ₀ = 28V	X(%):	10 60
		I ₂ (A):	100 40
		U ₂ (V):	19 16.1
 1-50Hz	U ₁ = 230V	I _{1max} = 13A	I _{1eff} = 5A
IP21S	H		



DRAPER TOOLS Ltd. SO53 1YF. U.K.

6. TECHNICAL DESCRIPTION

6.1 IDENTIFICATION

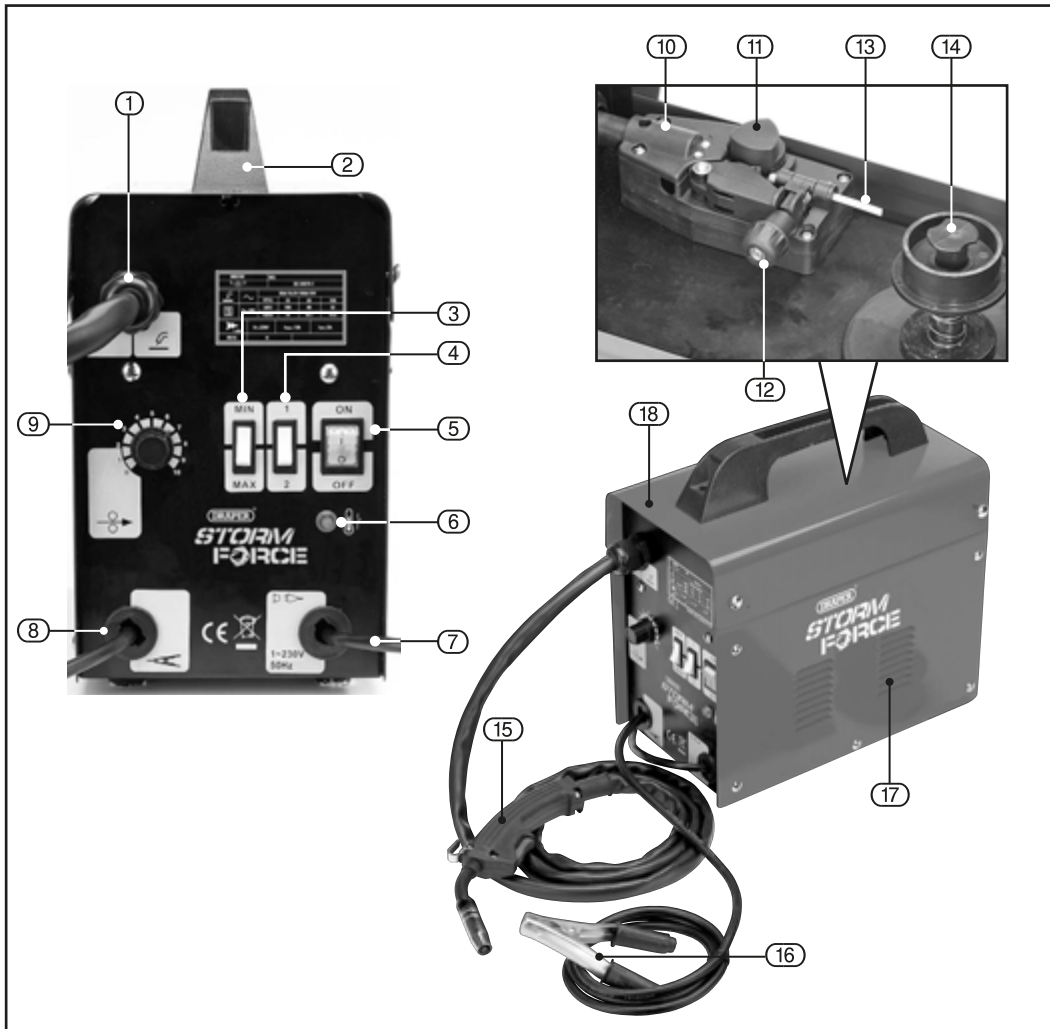

- ① Direct connection cable.
- ② Handle.
- ③ Min/Max switch.
- ④ 1/2 switch (welding current).
- ⑤ On/Off switch
- ⑥ Thermal cutout warning light.
- ⑦ Power cable.
- ⑧ Earth clamp cable.
- ⑨ Wire feed speed control.

- ⑩ Arm.
- ⑪ Tension roller.
- ⑫ Tensioner.
- ⑬ Wire guide.
- ⑭ Hub.
- ⑮ MIG torch.
- ⑯ Earth clamp.
- ⑰ Ventilation grille.
- ⑱ Top cover.

7. UNPACKING AND CHECKING

7.1 PACKAGING

Carefully remove the product from the packaging and examine it for any sign of damage that may have happened during shipping. Lay the contents out and check them against the parts shown below. If any part is damaged or missing, please contact the Draper Help Line (the telephone number appears on the Title page) and do not attempt to use the product.

The packaging material should be retained at least during the warranty period, in case the machine needs to be returned for repair.

Warning!

- Some of the packaging materials used may be harmful to children. Do not leave any of these materials in the reach of children.
- If any of the packaging is to be thrown away, make sure they are disposed of correctly, according to local regulations.

7.2 WHAT'S IN THE BOX

As well as the main product, there are several parts not fitted or attached to it.



(19) Hand held mask.

(20) Chipping hammer/wire brush.

(21) Spool of flux cored wire.

8. PREPARING THE WELDER

Note: Remove the plug from the socket before carrying out adjustment, servicing or maintenance.

8.1 LOCATION

Locate the machine in close proximity to the correct power supply and allow 500mm air gap around to ensure sufficient ventilation. There is one cooling fan located in the rear of the machine housing which must be kept clear. Equally, ensure no debris can be drawn into the machine.

Make certain the location does not pose any hazards as detailed in the safety instructions, before attempting to start the machine.

8.2 INSTALLING THE FLUX CORED FILLER WIRE - FIGS. 1 - 5

The welding machines are designed to accept the standard size drums of wire up to 1KG. The welding wire used must be of the flux cored type as this provides a means of shielding the weld pool from the atmosphere.

Do not let the filler wire become uncoiled or tangled as this will lead to problems with delivery to the welding torch.

Select the filler wire suitable for the parent metal and with a gauge to match the welder specification.

Note: If the welding machine is not regularly used, remove the wire which is prone to rusting and will cause feed problems next time.

- Lift the latch (18.1) to release the top cover (18).
- Remove the large plastic ring (14.1) (turning it clockwise). Sit the reel on to the hub (14) and make sure the peg locates in the back of the reel. Refit the large plastic ring (14.1).
- Fit the wire spool so that it feeds off the roll towards the wire drive unit.

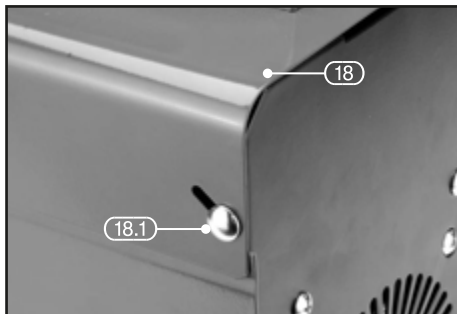

FIG.1

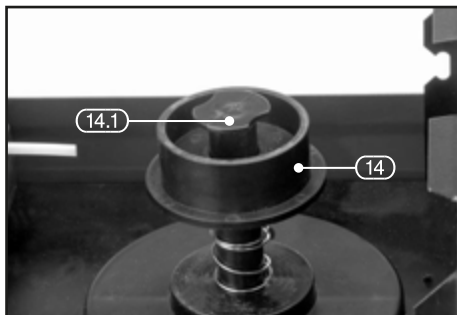

FIG.2



FIG.3

8. PREPARING THE WELDER

- Loosen tensioner (12) anticlockwise enough to swing it outwards and lift arm (10), moving the tension roller (11).
- Trim 10cm of wire and discard it, before flattening out the next 15cm. Do not let the wire lose tension.
- Pass the filler wire through the guide (13) and over the top of the drive roller fitted under securing nut (11). The drive roller comes with two grooves for different wire gauges. Remove nut to see the groove size that is NOT in use.

Note: The wire must sit in the appropriate groove for the wire gauge. The groove size is etched on the side of the roller. To reverse the roller, remove nut and flip the drive roller over before refitting nut (11).

- Make sure the wire is well inside the torch liner before closing the arm and (10) tensioner (12).
- Connect the welding machine to the power supply. Position the switch to 'on'.
- Unscrew/remove the gas shroud (15.1) and with a small spanner unscrew and remove the tip (15.2). Pull the trigger (15.3) and observe the wire feed mechanism. If the wire is being fed correctly it will come out of the swan neck. Pass the tip over the wire and secure back onto the swan neck. Do not over tighten. Resecure the gas shroud and trim the wire back as required.

Note: Ensure the tip size matches the wire size prior to installing.

8.3 NO GAS WELDING PRINCIPLE

For a successful weld joint, the molten metal must be protected from contaminating gases found in the air. This is achieved by using a flux cored filler wire. The flux is produced as the wire melts. The flux creates a coating over the weld and once cooled will need to be removed by chipping if off.

If allowed to cool naturally some areas of the flux may ping off of the weld by themselves due to thermal contraction for this reason it is recommended that eye protection is worn.

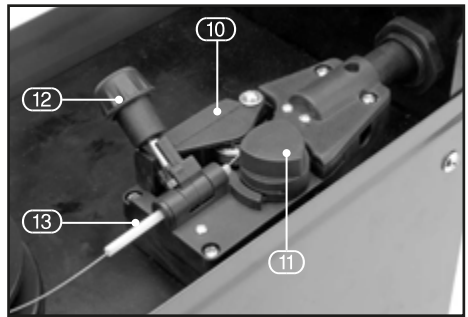

FIG.4

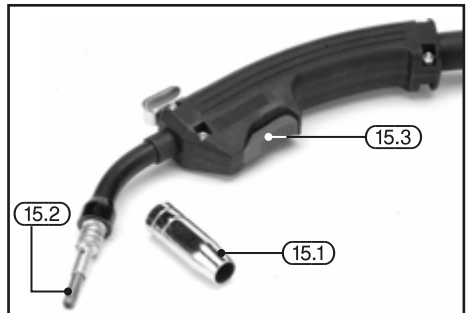

FIG.5

9. OPERATION

9.1 ON/OFF SWITCH

The on/off switch is a rocker switch. Press the top half in to switch the welder 'on' and the bottom half in to switch the welder 'off'.

9.2 WELDING CURRENT REGULATION SWITCHES - FIG. 6

The current regulation switches regulate the welders power in four steps. Min +1, Min +2 and Max +1, Max + 2. Regulate the welding current in conjunction with the wire speed to achieve the optimum arc for the workpiece thickness and type.

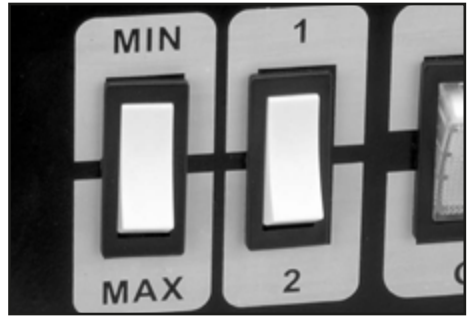

FIG.6

9.3 WIRE SPEED ADJUSTMENT - FIG. 7

Wire speed is dependent on material thickness and welding current. Being able to judge the correct wire speed based on the sound and quality of the weld will only come from practice.

- Too fast will result in holes blowing in the weld or the wire hitting the metal will force the torch backward.
- Too slow will result in the wire burning back to the torch into a ball and clogging the tip.

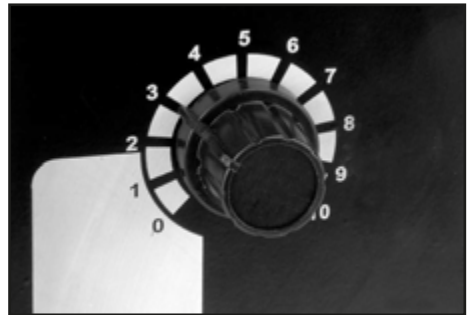

FIG.7

Note: When using the welder on a low amp setting/low wire speed, it is necessary that the wire drive tension is increased on the adjustment to avoid the spool stalling.

9.4 THERMAL CUT OUT

If the duty cycle of the welder is exceeded, the thermal cut out will activate to prevent damage to the internal components or further overheating.

When the thermal cut out warning light is lit, the welder must be left to cool down before it can be restarted.

9. OPERATION

9.5 MIG WELDING PRINCIPLES

The Mig welding process allows two similar materials to be fused together without altering the properties of the material. The electric arc created between the electrode (the welding wire) and the work piece produces the required heat for turning the metal into a molten state. The gas creates a shield around the arc and the molten metal, on this welder the shield comes from the flux cored welding wire that must be used.

The area to be welded and the earth point must be clean of grease, dirt, paint and rust. Clean with a wire brush as necessary. Position the earth clamp as close as possible to the working area and ensure a tight grip is achieved.

Select the welding current based on the thickness of the material. A thick piece will require a high current, however due to the duty cycle this will effect the welding time by significantly reducing it. A thin piece will only require minimal heat and so the current can be less. This will allow a longer period of welding. The position of the torch is critical to the arc and end results.

The position of the welding torch is important to achieve a good quality bead. Position the torch at approximately 35 vertically and 75 horizontally and up to 20mm* distance from the joint. 20mm is the maximum that can be achieved on the maximum setting. Ensure the gas shroud remains clean of spatter. Likewise and more importantly the wire feed tip must be kept clean to avoid the wire becoming blocked or restricted.

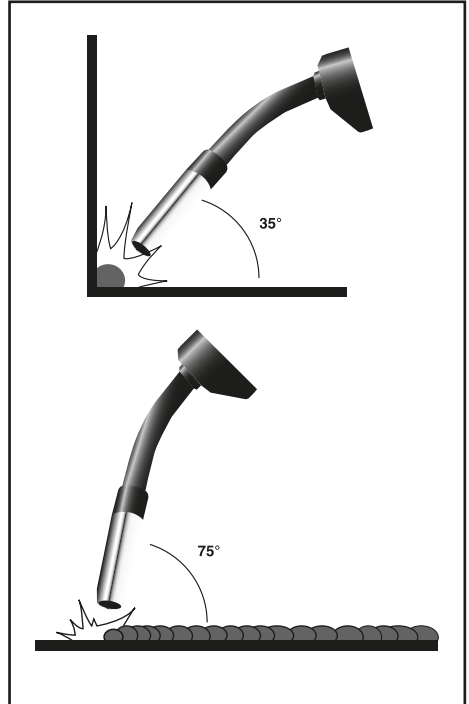



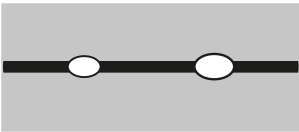

FIG.8

10. TROUBLESHOOTING

10.1 TROUBLESHOOTING GUIDE

Example	Term	Cause
 A cross-sectional diagram of a butt joint weld. The weld metal is shown as a dark semi-circle on top of the two metal pieces. There is a significant gap between the weld metal and the base metal, indicating that the weld did not penetrate into the joint.	Insufficient penetration.	<ul style="list-style-type: none">- Incorrect arc distance.- Welding current too low.- Wire speed too low.- Welding line not central to butt.
 A cross-sectional diagram of a butt joint weld. The weld metal is shown as a dark shape on top of the two metal pieces. The weld metal does not fuse to the base metal, instead overlapping it, which is a common defect.	Overlap.	<ul style="list-style-type: none">- Wire size too large for application.- Torch speed too slow.
 A cross-sectional diagram of a butt joint weld. The weld metal is shown as a dark shape on top of the two metal pieces. The weld metal is filled with numerous small black dots, representing pits or inclusions.	Pitting.	<ul style="list-style-type: none">- Contamination in the metal (eg rust).- Flux shield breakdown.- Incorrect arc distance.- Area cooling down too fast.
 A cross-sectional diagram of a butt joint weld. The weld metal is shown as a dark, wavy line on top of the two metal pieces. The surface of the weld is irregular and uneven, indicating it is untidy.	Untidy weld.	<ul style="list-style-type: none">- Unsteady torch movement.- Worn wire tip.
 A cross-sectional diagram of a butt joint weld. The weld metal is shown as a dark line on top of the two metal pieces. There are two distinct oval-shaped holes in the metal, one on each side of the weld, indicating that the metal has been burned through.	Burn through.	<ul style="list-style-type: none">- Current too high for material thickness.- Torch speed too slow.

11. MAINTENANCE

11.1 MAINTENANCE

Warning: Remove the plug from the power supply. Periodically the welder must be checked as detailed below.

- Check the torch cable and ground cable connections.
- Clean the contact tip and the gas shroud with an iron brush. Replace if worn.
- Clean the outside of the welder with a damp cloth.
- Every time the wire spool is replaced:
- Check the alignment, cleanliness and state of wear of the wire roll.
- Remove any metal powder deposited on the wire feeder mechanism and then dry with compressed air.
- Check the condition of the warning labels.
- Replace any worn parts.

12. EXPLANATION OF SYMBOLS

12.1 EXPLANATION OF SYMBOLS



Read the instruction manual.



Wear protective gloves.



Welding mask must be used.



Thermal cut out.



Metal inert gas.



Keep away from rain.

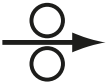

Wire feed.



Keep out of the reach of children.



Wire thickness.



Mandatory action required.



Warning!
Read the instruction manual



Danger!
Electricity.
Keep your distance.



WEEE
Do not dispose of Waste Electrical & Electronic Equipment in with domestic rubbish.



Conforms to all relevant safety standards.

12. DISPOSAL

12.1 DISPOSAL

- At the end of the machine's working life, or when it can no longer be repaired, ensure that it is disposed of according to national regulations.
- Contact your local authority for details of collection schemes in your area.

In all circumstances:

- Do not dispose of power tools with domestic waste.
- Do not incinerate.
- Do not dispose of WEEE* as unsorted municipal waste.



* *Waste Electrical & Electronic Equipment.*

CONTACTS

Draper Tools Limited, Hursley Road,
Chandler's Ford, Eastleigh, Hampshire. SO53 1YF. U.K.

Help Line: (023) 8049 4344

Sales Desk: (023) 8049 4333

Internet: drapertools.com

E-mail: sales@drapertools.com

General Enquiries: (023) 8026 6355

Service/Warranty Repair Agent:

For aftersales servicing or warranty repairs, please contact the Draper Tools Help Line for details of an agent in your local area.

YOUR DRAPER STOCKIST

TACH0520

©Published by Draper Tools Limited.

No part of this publication may be reproduced, stored in a retrieval system or transmitted in any form or by any means, electronic, mechanical photocopying, recording or otherwise without prior permission in writing from Draper Tools Ltd.