

ALPHA WIRE COMPANY
CUSTOMER PRODUCT SPECIFICATION

Part Numbers: 3580/9 – 3580/64
Spec Number: C3580-9
Page 1 of 2 Pages

Issue: 3
Issue Date: 4/29/2004
Effective Date: 5/28/2004

A. Construction

- 1) Conductor
 - a) Material Tinned Copper, Per ASTM B-33
 - b) AWG, Stranding 28, 7/36

- 2) Insulation
 - a) Material Polyvinyl Chloride, Extruded
 - b) Nominal Wall Thickness 0.010
 - c) Min. Avg. Wall Thickness 0.009
 - d) Min. Point Thickness 0.007
 - e) Diameter 0.035 +/- 0.002
 - f) Color Gray, Red Polarity Stripe on Leading Edge

- 3) Assembly
 - a) Number of Conductors See Table 1
 - b) Configuration Flat Cable
 - c) Center to Center Spacing 0.050 +/- 0.002
 - d) Width See Table 1
 - e) Span See Table 1
 - f) Surface Print Per Alpha Standard SP-001
 - g) Print Legend ALPHA - *

* - Factory Designation

Part Number	Conductors	Width	Span
3580/9	9	.450 +/- .010	.400 +/- .006
3580/10	10	.500 +/- .010	.450 +/- .008
3580/14	14	.700 +/- .010	.650 +/- .008
3580/15	15	.750 +/- .015	.700 +/- .008
3580/16	16	.800 +/- .015	.750 +/- .008
3580/20	20	1.000 +/- .015	.950 +/- .008
3580/24	24	1.200 +/- .015	1.150 +/- .008
3580/25	25	1.250 +/- .015	1.200 +/- .008
3580/26	26	1.300 +/- .015	1.250 +/- .008
3580/34	34	1.700 +/- .015	1.650 +/- .008
3580/37	37	1.850 +/- .015	1.800 +/- .011
3580/40	40	2.000 +/- .015	1.950 +/- .011
3580/50	50	2.500 +/- .015	2.450 +/- .011
3580/60	60	3.000 +/- .015	2.950 +/- .011
3580/64	64	3.200 +/- .015	3.150 +/- .011

ALPHA WIRE COMPANY
CUSTOMER PRODUCT SPECIFICATION

Part Numbers: 3580/9 – 3580/64
Spec Number: C3580-9
Page 2 of 2 Pages

Issue: 3
Issue Date: 4/29/2004
Effective Date: 5/28/2004

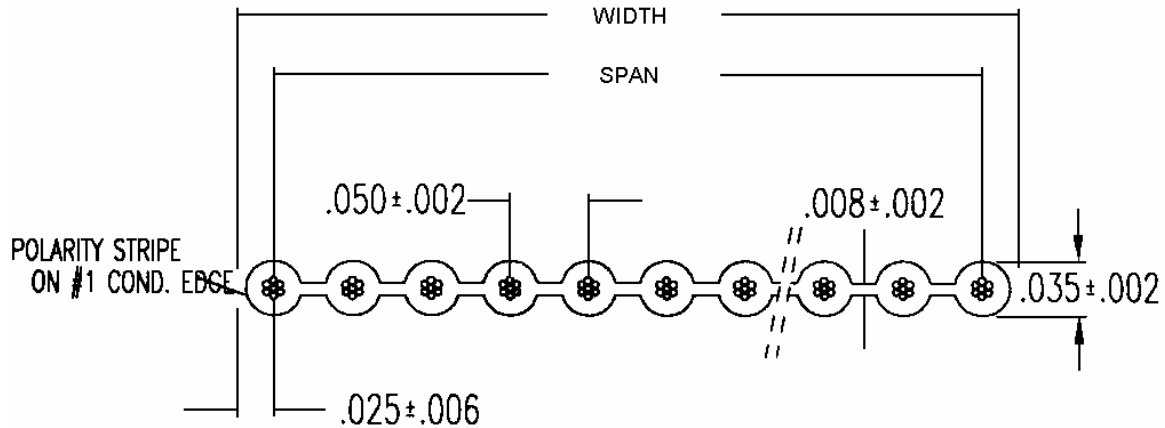

B. Industry Approvals and Ratings

- | | |
|--------------------------|---------------------------------|
| 1) UL | UL Standard 758, AWM Style 2651 |
| 2) Voltage Rating | VW-1 |
| 3) Temperature Rating | 300 Volts |
| 4) Conductor Unbalance | 105°C |
| 5) Voltage Withstand | 5% Maximum |
| 6) Insulation Resistance | 2000 Volts RMS, Minimum |
| 7) Impedance | 500 MΩ-1000 feet, Minimum |
| 8) Capacitance | 105 Ω, Nominal (G-S-G) |
| 9) Propagation Delay | 14.0 pf/ft., Nominal (G-S-G) |
| | 1.40 ns/ft., Nominal |

C. Packaging Requirements

- | | |
|---------------------|---|
| 1) Standard Package | 100 feet (Max. 2 of lengths, 25 ft. Min Length) |
|---------------------|---|