

RoHS Compliant

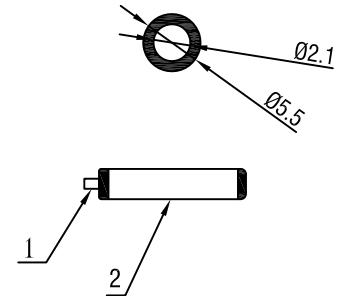
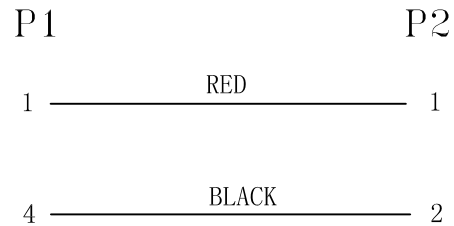
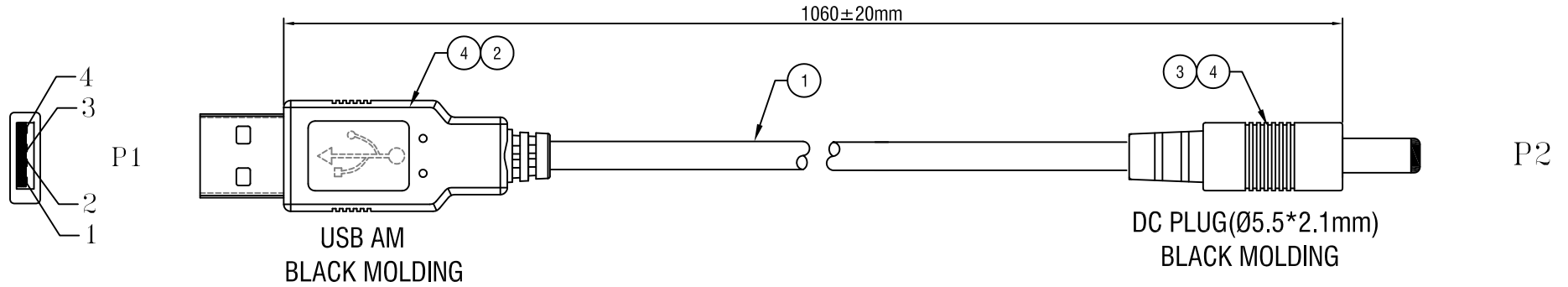

Electrical Test:

- 1.100% TEST OPEN SHORT MIS-WIRE
- 2.CONTACT RESISTANCE:3Ω MAX.
- 3.INSULATION RESISTANCE:5MΩ MIN.
- 4.HI-PORT:300V DC/10MS

D		
C		
B	Revise the length to end to end	2015-12-16
VER.A	REVISE	DATE

Company: CONRAD

Item	1359888	
Draw	<i>Andri</i>	Date: 2015.05.19
Approval		
Duty	F16/F46	

NUMBER	PRODUCT SPECIFICATIONS	Quantity	Unit
4	45P PVC BLACK		G
3	DC PLUG Ø5.5*2.1mm (BLACK INSULATOR NICKEL PLATED)		G
2	USB 2.0 AM (WHITE INSULATOR NICKEL PLATED)	1	PCS
1	UL2725 28#*2C OD:3.5mm BLACK COLOR PVC JACKET	1	PCS

RoHS Compliant

CONRAD
GERMANY
BEST NO.: 1359888
PCS.: 100 PCS
MODEL NO.: U00D0082197
ORDER NO.:
WEIGHT(KG.): KGS

外箱側麥

CONRAD
HAMBURG
C/NO.:
MADE IN CHINA

外箱正麥

透明圆贴
15*15mm

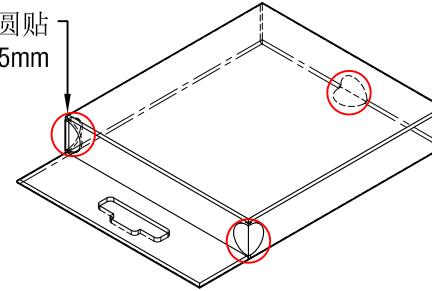

產品直接裝入彩盒內(105*140*20mm)

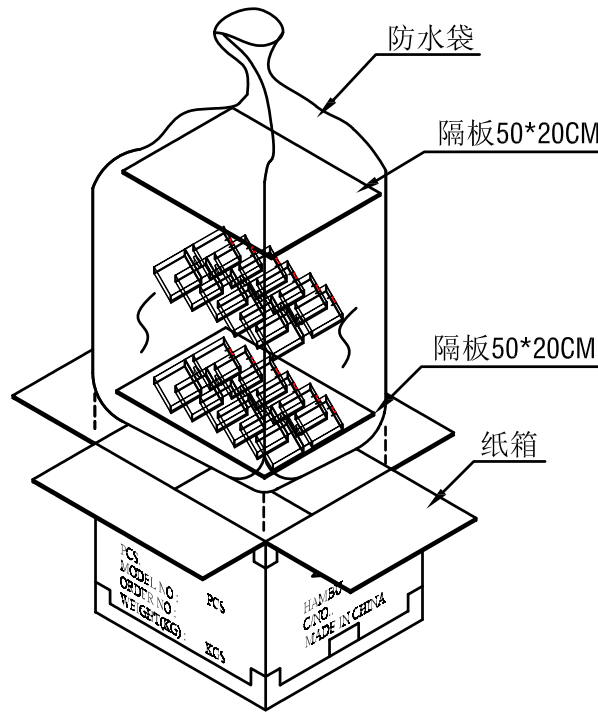
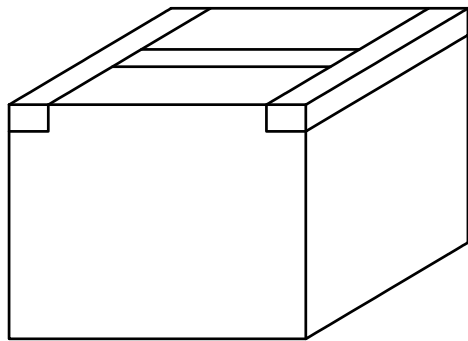

100PCS/CTN (580*230*230mm) 一排25pcs 上下兩排

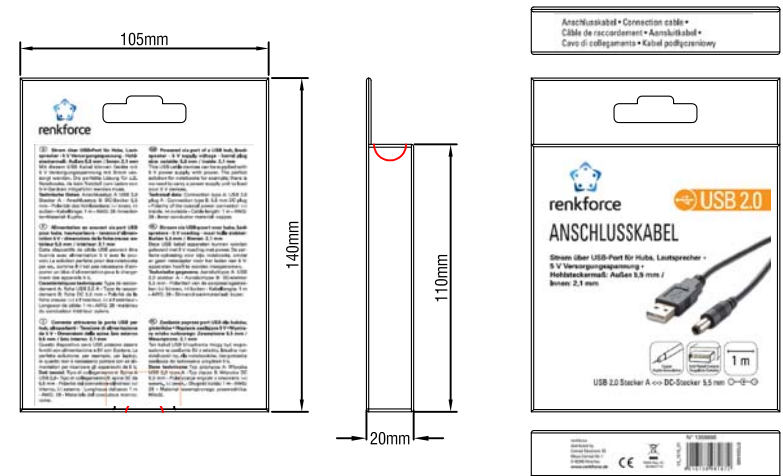

D	去掉PE袋包裝	2015-12-16
C	修改彩盒為第二版	2015.07.27
B	修改外箱尺寸	2015.07.22
VER.A	REVISE	DATE

Company: CONRAD

Item	1359888	
Draw	<i>Andi</i>	Date: 2015.05.19
Approval		
Duty	F16/F46	

NUMBER	PRODUCT SPECIFICATIONS		Quantity	Unit
--------	------------------------	--	----------	------