

- Limited Lifetime Warranty
- Medical Approvals
- Universal Input (85 - 265VAC)
- High Efficiency
- Broad 30W to 1500W product range
- RoHS Compliant Design

## HWS-/ME Series

Single Output  
Medical Power Supplies

### Key Market Segments & Applications



### HWS-/ME Features and Benefits

#### Features

- Limited Lifetime Warranty
- Medical Approvals
- Wide Range AC Input

#### Benefits

- Lower Cost of Ownership
- Reduces System Approval Times
- Supports Global Use

### Specifications

ITEM	MODELS		HWS30A	HWS100A	HWS300	HWS600	HWS1000	HWS1500
			HWS50A	HWS150A				
Input Voltage	(4)		85-265VAC (47-63Hz) or 120-370VDC		85-265VAC (47-63Hz) or 120-330VDC			85-265VAC (47-63Hz)
Input Current (Typ)	(1)	A	0.65 / 0.4	1.3 / 0.65	4.1 / 2.1	8.1 / 3.9	13.5/7.0	19/10
Inrush Current	(1)	A	14 / 28		20 / 40			
Power Factor / Flicker			Meets EN61000-3-2, EN61000-3-3					
Temperature Coefficient			<0.02%/°C					
Overcurrent Protection			>104%					
Overvoltage Protection		V	Yes (See table on page 2)					
Hold Up Time (Typ)		ms	20					
Leakage Current (60Hz)	(2)	mA	<0.5mA					
Remote Sense			No			Yes		
Indicator			Green LED = ON					
Remote On/Off			No			Yes (Isolated from output)		
Parallel operation			No			Single wire conn. (5 units max)		
DC Good			No			Yes		
Voltage Programming			No					Yes
Operating Temperature and Derating			HWS30A-150A: -10°C to +70°C, (derating applies above 50°C please refer to individual model specification for derating graph) HWS300-1500: -10°C to +70°C, (-10 to +50°C: 100%, derate linearly to 50% load from +50°C to +70°C)					
Storage Temperature		°C	-30°C to +85°C					
Humidity (non condensing)			Operating: 30 - 90%RH (10 -90% on HWS300-1500), Non operating 10 - 95%RH					
Cooling			Convection			Internal fan		
Withstand Voltage	(3)		Input to Ground 2kVAC, Input to Output 3kVAC, Output to Ground 500VAC for 1 min.					
Isolation Resistance			>100MΩ at 25°C & 70%RH, Output to Ground 500VDC, >10MΩ Output to remote on/off 100VDC					
Vibration (non operating)			10 - 55Hz (1 min sweep), 19.6m/s <sup>2</sup> constant, X, Y, Z axis, one hour each					
Shock (in packaging)			< 196.1m/s <sup>2</sup>					
Safety Agency Approvals	(2)		ES60601-1, EN60601-1, CSA-C22.2 No6011-M90 (C-UL) (basic insulation), CE Mark					
Line Dip			Complies with SEMI F47 (200VAC line only)					
Conducted & Radiated EMI Immunity			EN55011 / EN55022-B, FCC-B, VCCI-B (HWS600 & 1500 Class A) IEC61000-4-2, -3, -4, -5, -6, -8, -11, IEC61000-6-2					
Weight (Typ)		g	220	450	1000	1600	3200	3800
Size (WxHxD)			26 x 82 x 95	33 x 82 x 160				
(with cover except 30 & 50W)		mm	26 x 82 x 120	42 x 82 x 160	61 x 82 x 165	100 x 82 x 165	126.5 x 82 x 240	280 x 82 x 126.5
Warranty			Limited Lifetime Warranty (See TDK-Lambda terms & conditions)					

Notes: (1) 100/200VAC input. (2) See clause 19.5DV.2 of UL60601 for equipment in proximity of patient. (3) HWS300-600 2.5kVAC Input to ground. (4) Consult Sales Office for use under DC Input conditions

Model Selector									
Model	Voltage	Adjust Range	Max Curr(A) <sup>4</sup>	Max Power(W)	Load Reg(mV)	Line Reg(mV)	Ripple Noise(mV)	Overvoltage (V)	Efficiency (typ)% <sup>1</sup>
HWS30A-5/ME	5V	4.0 - 6.0	6	30	40	20	120	6.25-7.25	77/80
HWS50A-5/ME	5V	4.0 - 6.0	10	50	40	20	120	6.25-7.25	82/84
HWS100A-5/ME	5V	4.0 - 6.0	20	100	40	20	120	6.25-7.25	83/86
HWS150A-5/ME	5V	4.0 - 6.0	30	150	40	20	120	6.25-7.25	83/86
HWS600-5/ME	5V	4.0 - 6.0	120	600	30	20	120	6.25-7.25	80/83
HWS30A-12/ME	12V	9.6 - 14.4	2.5	30	96	48	150	15-17.4	81/83
HWS50A-12/ME	12V	9.6 - 14.4	4.3	51.6	96	48	150	15-17.4	81/83
HWS100A-12/ME	12V	9.6 - 14.4	8.5	102	96	48	150	15-17.4	83/86
HWS150A-12/ME	12V	9.6 - 14.4	13	156	96	48	150	15-17.4	83/86
HWS300-12/ME	12V	9.6 - 14.4	27	324	72	48	150	15-17.4	80/83
HWS600-12/ME	12V	9.6 - 14.4	53	636	72	48	150	15-17.4	80/83
HWS30A-15/ME	15V	12.0 - 18.0	2	30	120	60	150	18.8-21.8	81/83
HWS50A-15/ME	15V	12.0 - 18.0	3.5	52.5	120	60	150	18.8-21.8	81/83
HWS100A-15/ME	15V	12.0 - 18.0	7	105	120	60	150	18.8-21.8	83/86
HWS150A-15/ME	15V	12.0 - 18.0	10	150	120	60	150	18.8-21.8	83/86
HWS300-15/ME	15V	12.0 - 18.0	22	330	90	60	150	18.8-21.8	82/85
HWS600-15/ME	15V	12.0 - 18.0	43	645	90	60	150	18.8-21.8	81/84
HWS30A-24/ME	24V	19.2 - 28.8	1.3	31.2	192	96	200	30-34.8	83/86
HWS50A-24/ME	24V	19.2 - 28.8	2.2	52.8	192	96	150	30-34.8	82/84
HWS100A-24/ME	24V	19.2 - 28.8	4.5	108	192	96	150	30-34.8	84/87
HWS150A-24/ME	24V	19.2 - 28.8	6.5	156	192	96	150	30-34.8	85/88
HWS300-24/ME	24V	19.2 - 28.8	14 (16.5 pk)	336	144	96	150	30-34.8	82/85
HWS600-24/ME	24V	19.2 - 28.8	27 (31 pk)	648	144	96	150	30-34.8	82/85
HWS1000-24/ME	24V	19.2 - 28.8	46 (58.5 pk)	1104	150	96	150	30-34.8	85/87
HWS1500-24/ME	24V	4.8 - 28.8 <sup>(7)</sup>	65/70 <sup>(1)</sup> (105pk <sup>(5)</sup> )	1560/1680 <sup>(1)</sup> (2520 pk <sup>(5)</sup> )	144	96	200	30-34.8	84/88
HWS1000-36/ME	36V	28.8 - 43.2	30.7 (39 pk)	1104	150	144	200	45-49.7	85/88
HWS1500-36/ME	36V	7.2 - 43.2 <sup>(6)</sup>	42/46.5 <sup>(1)</sup> (70 pk) <sup>(5)</sup>	1512/1674 <sup>(1)</sup> (2520 pk <sup>(5)</sup> )	150	144	200	34-49.7	84/88
HWS30A-48/ME	48V	38.4 - 52.8	0.65	31.2	384	192	200	55.2-64.8	82/83
HWS50A-48/ME	48V	38.4 - 52.8	1.1	52.8	384	192	200	55.2-64.8	83/85
HWS100A-48/ME	48V	38.4 - 52.8	2.1	100.8	384	192	200	55.2-64.8	84/87
HWS150A-48/ME	48V	38.4 - 52.8	3.3	158.4	384	192	200	55.2-64.8	85/88
HWS300-48/ME	48V	38.4 - 52.8	7	336	288	192	350	55.2-64.8	82/85
HWS600-48/ME	48V	38.4 - 52.8	13	624	288	192	350	55.2-64.8	83/86
HWS1000-48/ME	48V	38.4 - 52.8	23	1104	300	192	200	55.2-60	86/88
HWS1500-48/ME	48V	9.6 - 52.8 <sup>(6)</sup>	32	1536	288	192	200	55.2-64.8	86/90

- (4) Peak load for 10s maximum on time, 35% duty cycle      (5) 200-265AC Input  
 (6) Using voltage programming input - see installation manual for details

Options	
Suffix	Description
Blank	No cover (except HWS300-1500 cover fitted) as standard
/A	Cover fitted (egHWSA100-24/MEA)

## Outline Drawing HWS100A/MEA Series

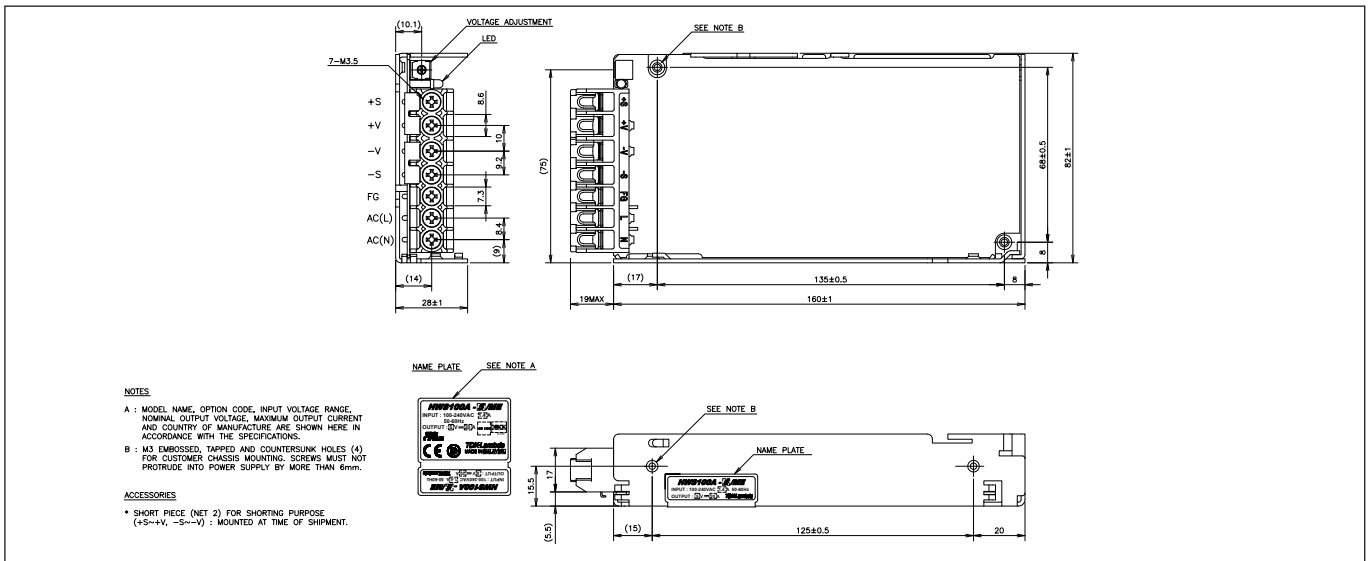

## Outline Drawing HWS300 Series

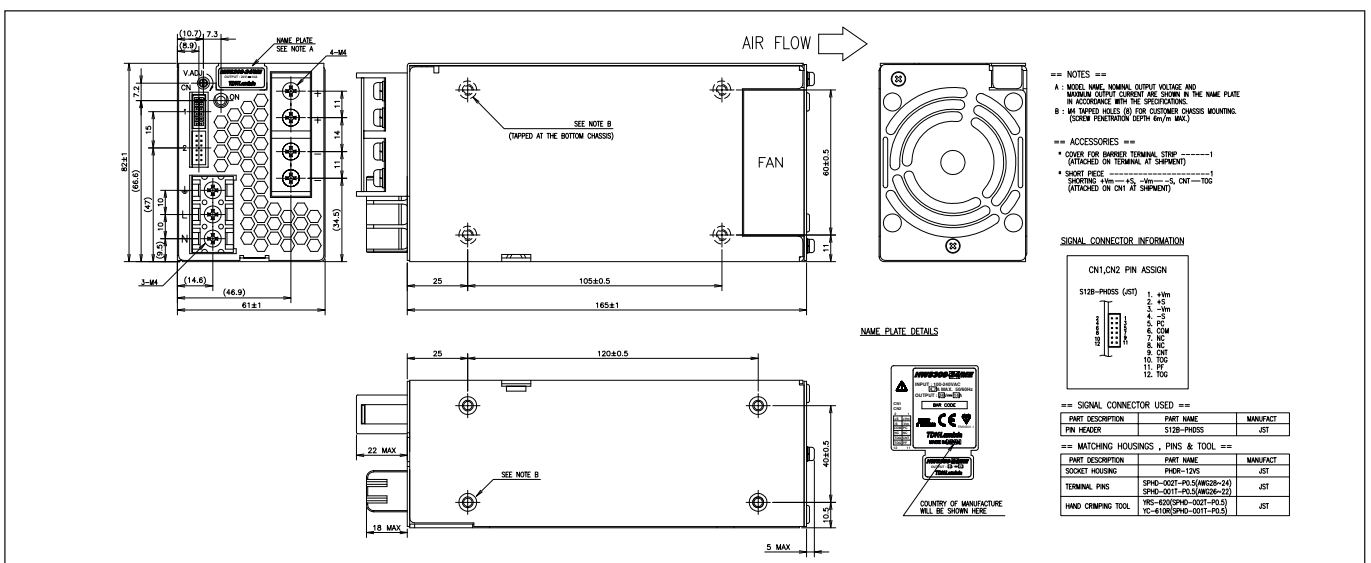

## Outline Drawing HWS1500 Series

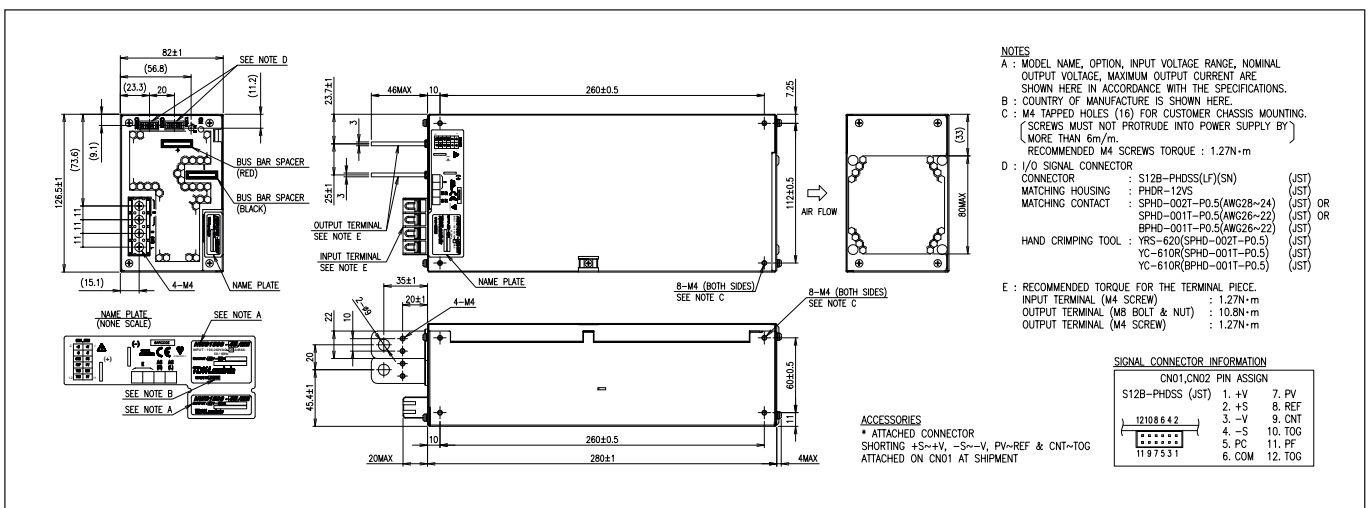



**TDK-Lambda France SAS**

ZAC des Delaches  
 CS 41077  
 9 rue Thuillere  
 91978 Villebon Courtaboeuf  
 France  
 Tel: +33 1 60 12 71 65  
 Fax: +33 1 60 12 71 66  
[france@fr.tdk-lambda.com](mailto:france@fr.tdk-lambda.com)  
[www.fr.tdk-lambda.com](http://www.fr.tdk-lambda.com)



**Italy Sales Office**

Via dei Lavoratori 128/130  
 20092 Cinisello Balsamo (MI)  
 Italy  
 Tel: +39 02 61 29 38 63  
 Fax: +39 02 61 29 09 00  
[info.italia@it.tdk-lambda.com](mailto:info.italia@it.tdk-lambda.com)  
[www.it.tdk-lambda.com](http://www.it.tdk-lambda.com)



**Netherlands**

[info@tdk-lambda.nl](mailto:info@tdk-lambda.nl)  
[www.tdk-lambda.nl](http://www.tdk-lambda.nl)



**TDK-Lambda Germany GmbH**

Karl-Bold-Strasse 40  
 77855 Achern  
 Germany  
 Tel: +49 7841 666 0  
 Fax: +49 7841 5000  
[info.germany@de.tdk-lambda.com](mailto:info.germany@de.tdk-lambda.com)  
[www.de.tdk-lambda.com](http://www.de.tdk-lambda.com)



**Austria Sales Office**

Aredstrasse 22  
 2544 Leobersdorf  
 Austria  
 Tel: +43 2256 655 84  
 Fax: +43 2256 645 12  
[info.germany@de.tdk-lambda.com](mailto:info.germany@de.tdk-lambda.com)  
[www.de.tdk-lambda.com](http://www.de.tdk-lambda.com)



**Scandinavia Sales Office**

Valdemarsgade 7  
 4100 Ringsted  
 Denmark  
 Tel: +45 24 63 95 65  
 Fax: +45 69 80 44 99  
[info@de.tdk-lambda.com](mailto:info@de.tdk-lambda.com)  
[www.emea.tdk-lambda.com](http://www.emea.tdk-lambda.com)



**Switzerland Sales Office**

Bahnhofstrasse 50  
 8305 Dietlikon  
 Switzerland  
 Tel: +41 44 850 53 53  
 Fax: +41 44 850 53 50  
[info@de.tdk-lambda.com](mailto:info@de.tdk-lambda.com)  
[www.de.tdk-lambda.com](http://www.de.tdk-lambda.com)



**TDK-Lambda UK Ltd.**

Kingsley Avenue  
 Ilfracombe  
 Devon EX34 8ES  
 United Kingdom  
 Tel: +44 (0) 12 71 85 66 66  
 Fax: +44 (0) 12 71 86 48 94  
[powersolutions@uk.tdk-lambda.com](mailto:powersolutions@uk.tdk-lambda.com)  
[www.uk.tdk-lambda.com](http://www.uk.tdk-lambda.com)



**TDK-Lambda Ltd.**

Kibbutz  
 Givat Hashlosha 48800  
 Israel  
 Tel: +9 723 902 4333  
 Fax: +9 723 902 4777  
[info@tdk-lambda.co.il](mailto:info@tdk-lambda.co.il)  
[www.tdk-lambda.co.il](http://www.tdk-lambda.co.il)



**C.I.S.**

**Commercial Support:**  
 Tel: +7 (495) 665 2627  
**Technical Support:**  
 Tel: +7 (812) 658 0463  
[info@tdk-lambda.ru](mailto:info@tdk-lambda.ru)  
[www.tdk-lambda.ru](http://www.tdk-lambda.ru)

**Local Distribution**

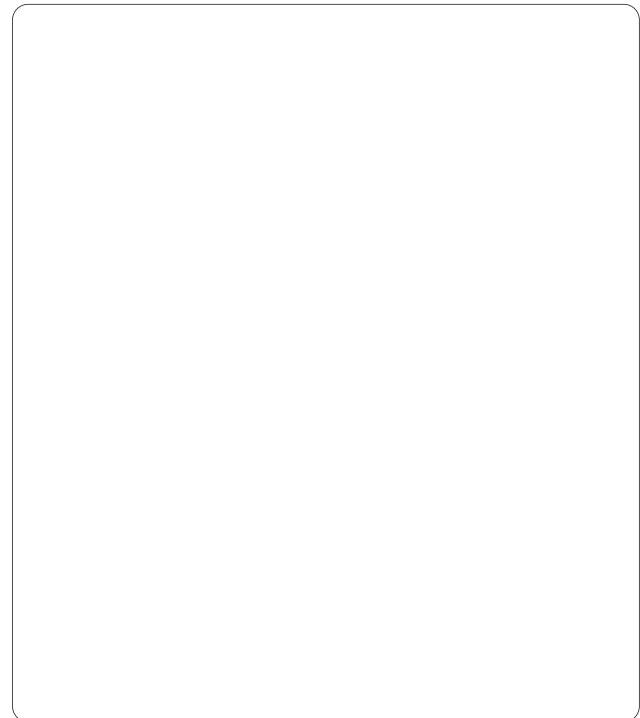

[www.emea.tdk-lambda.com](http://www.emea.tdk-lambda.com)

**HWS30A/ME**

SPECIFICATIONS

A256-01-01/ME

ITEMS		MODEL	HWS30A -5/ME	HWS30A -12/ME	HWS30A -15/ME	HWS30A -24/ME	HWS30A -48/ME	
1	Nominal Output Voltage	V	5	12	15	24	48	
2	Maximum Output Current	A	6	2.5	2	1.3	0.65	
3	Maximum Output Power	W	30.0	30.0	30.0	31.2	31.2	
4	Efficiency (Typ.) (*1)	100VAC	%	80	84	85	86	86
		200VAC	%	82	86	87	88	87
5	Input Voltage Range (*2)	-	85 - 265VAC (47 - 63Hz) or 120 - 370VDC					
6	Input Current (Typ.) (*1)	A	0.65/0.4					
7	Inrush Current (Typ.) (*1)(*3)	-	14A at 100VAC, 28A at 200VAC, Ta=25°C, Cold Start					
8	PFHC	-	Designed to meet IEC61000-3-2					
9	Voltage Fluctuations / Flicker Emissions	-	Designed to meet IEC61000-3-3					
10	Output Voltage Range	V	4.0 - 6.0	9.6 - 14.4	12.0 - 18.0	19.2 - 28.8	38.4 - 52.8	
11	Maximum Ripple & Noise (*4)	0≤Ta≤70°C	mV	120	150	150	150	200
		-10≤Ta<0°C	mV	160	180	180	180	240
12	Maximum Line Regulation (*5)	mV	20	48	60	96	192	
13	Maximum Load Regulation (*6)	mV	40	96	120	150	240	
14	Temperature Coefficient	-	Less than 0.02%/°C					
15	Over Current Protection (*7)	A	6.3 ≤	2.62 ≤	2.1 ≤	1.36 ≤	0.68 ≤	
16	Over Voltage Protection (*8)	V	6.25 - 7.25	15.0 - 17.4	18.8 - 21.8	30.0 - 34.8	55.2 - 64.8	
17	Hold-up Time (Typ.) (*1)	-	20ms					
18	Leakage Current (*9)	-	Less than 0.5mA. 0.2mA (Typ) at 100VAC / 0.4mA (Typ) at 230VAC					
19	Remote Sensing	-	-					
20	Parallel Operation	-	-					
21	Series Operation	-	Possible					
22	Operating Temperature (*10)	-	-10 to +70°C (-10 to +50°C:100%, +60°C:60%, +70°C:40%)					
23	Operating Humidity	-	30 to 90%RH (No Condensing)					
24	Storage Temperature	-	-30 to +85°C					
25	Storage Humidity	-	10 to 95%RH (No Condensing)					
26	Cooling	-	Convection Cooling					
27	Withstand Voltage	-	Input - FG : 2kVAC (20mA), Input - Output : 3kVAC (20mA) Output - FG : 500VAC (20mA) for 1min					
28	Isolation Resistance	-	More than 100MΩ at 25°C and 70%RH Output - FG : 500VDC					
29	Vibration	-	At no operating, 10 - 55Hz (Sweep for 1min) 19.6m/s <sup>2</sup> Constant, X,Y,Z 1hour each.					
30	Shock	-	Less than 196.1m/s <sup>2</sup>					
31	Safety (*11)	-	Approved by ES60601-1, EN60601-1, CSA-C22.2 No.60601-1					
32	Line DIP	-	Designed to meet SEMI-F47 (200VAC Line only)					
33	Conducted Emission (*12)	-	Designed to meet EN55011/EN55022-B, FCC-B, VCCI-B					
34	Radiated Emission (*12)	-	Designed to meet EN55011/EN55022-B, FCC-B, VCCI-B					
35	Immunity (*12)	-	Designed to meet IEC61000-6-2 IEC61000-4-2, -3, -4, -5, -6, -8, -11					
36	Weight (Typ.)	-	200g					
37	Size (W x H x D)	mm	26.5 x 82 x 95 ( Refer to Outline Drawing )					

\*Read instruction manual carefully, before using the power supply unit.

=NOTES=

- \*1. At 100VAC/200VAC, Ta=25°C, nominal output voltage and maximum output power.
- \*2. For cases where conformance to various safety specs (ES, CSA, EN) are required, to be described as 100 - 240VAC(50 - 60Hz).
- \*3. Not applicable for the inrush current to Noise Filter for less than 0.2ms.
- \*4. Measure with JEITA RC-9131B probe, Bandwidth of scope :100MHz.  
For start up at low ambient temperature and low input voltage, output ripple noise might not meet specification.  
However, specification can be met after one second.
- \*5. 85 - 265VAC, constant load.
- \*6. No load-Full load, constant input voltage.
- \*7. Hiccup with automatic recovery. Avoid to operate at over load or short circuit condition.
- \*8. OVP circuit will shut down output, manual reset (Re power on).
- \*9. Measured by the each measuring method of ES, CSA and EN (at 60Hz).
- \*10. Output Derating  
- Derating at standard mounting. Refer to OUTPUT DERATING CURVE (A256-01-02\_ ).  
- Load (%) is percent of maximum output power or maximum output current, do not exceed its derating of maximum load.
- \*11. As for ES60601-1, EN60601-1 and CSA-C22.2 No.60601-1, 3rd Edition and MOOP level.
- \*12. The power supply is considered a component which will be installed into a final equipment.  
The final equipment should be re-evaluated that it meets EMC directives.