

Specification:

Material:

Plastic material: polypropylene

Flammability rating: UL94 HB, UL File No. E216959

Temperature range: -10°C to $+100^{\circ}\text{C}$

Springs: nickel plated spring steel

PC pins: rolled steel, nickel plated

Rivets: brass, nickel plated

Contact resistance: under $50\text{m}\Omega$ for +/- contacts per EIA-540J000

RoHS 2 compliant

Mounting instructions:

Use 2-56 machine screws or eyelets 0.089in OD by 0.15in flange

Stimpson GS-3 series or equivalent.

Adhesive and double sided tapes also work well.

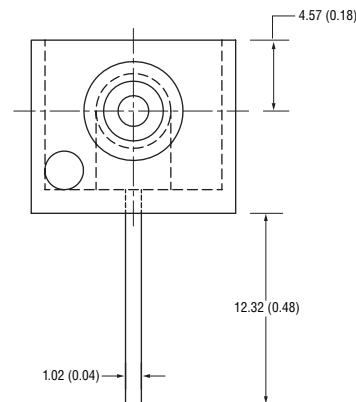
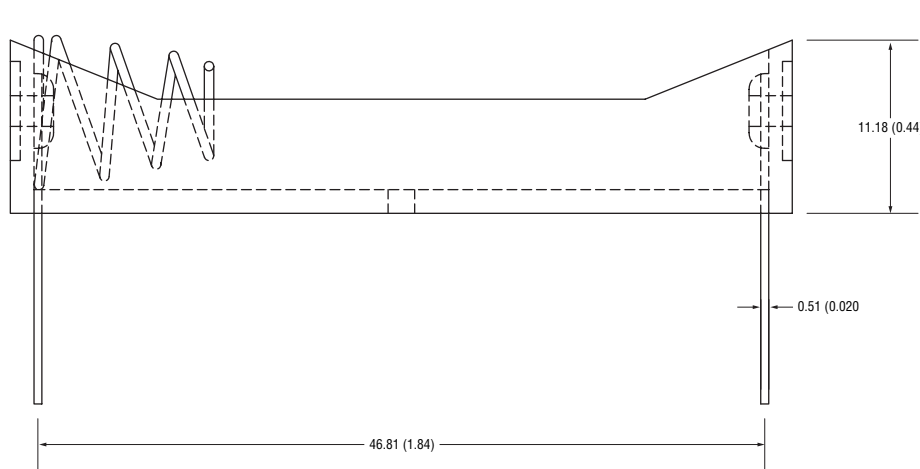

Tolerances	mm (inches)
Decimal	± 0.5 (0.020)
Fractional	± 0.8 (0.030)
Angular	$\pm 3^{\circ}$

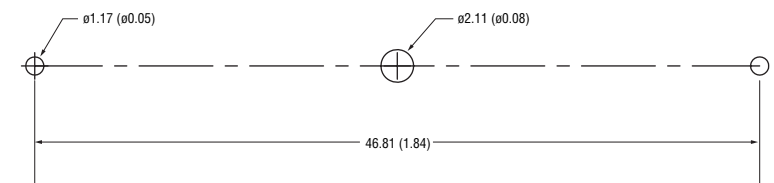

PCB LAYOUT