

SPECIFICATION FOR APPROVAL

Ideal Power

CUSTOMER: _____

DESCRIPTION: 25CH REV: (A0)

MODEL NO: UL轉換頭 PART NO: HKSC-100998
ROHS Compliance

DESIGNED NO: 100998-1130 DATE: DEC.01th.2011

CUSTOMER APPROVED SIGNATURES			VENDOR APPROVED SIGNATURES		
					

MODEL NO. :	UL轉換頭	PAGE NO. :	1 OF 3
PART NO. :	HKSC-100998	ISSUED DATE:	2011.12.01
DESCRIPTION :		REV:	(A0)

UNIT: mm

UL

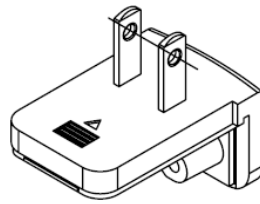

待包裝成品

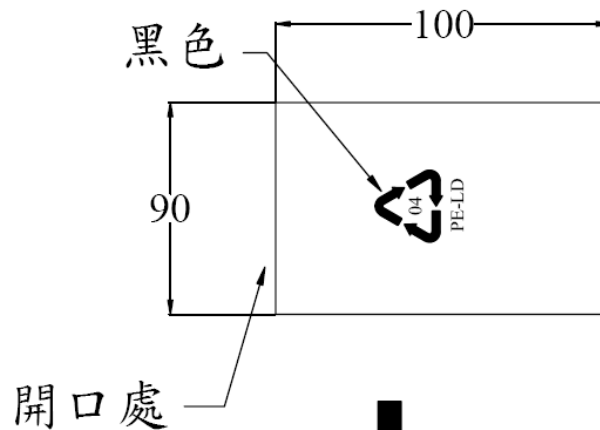

PE bag

Length : 100

Width : 90

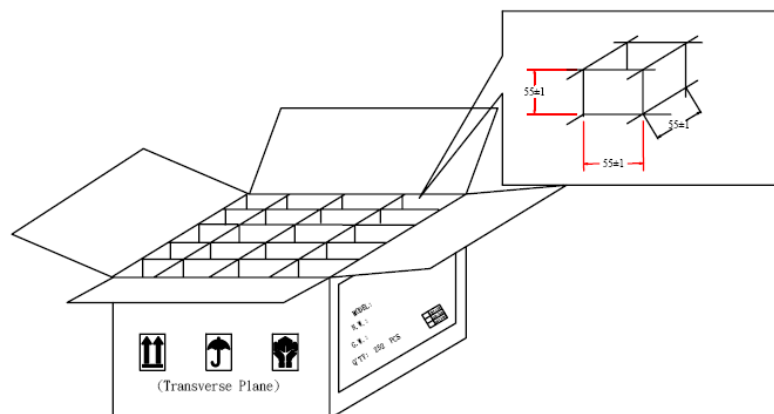

外箱

MODEL NO. :	UL轉換頭	PAGE NO. :	2 OF 3
PART NO. :	HKSC-100998	ISSUED DATE:	2011.12.01
DESCRIPTION :		REV:	(A0)

UNIT: mm

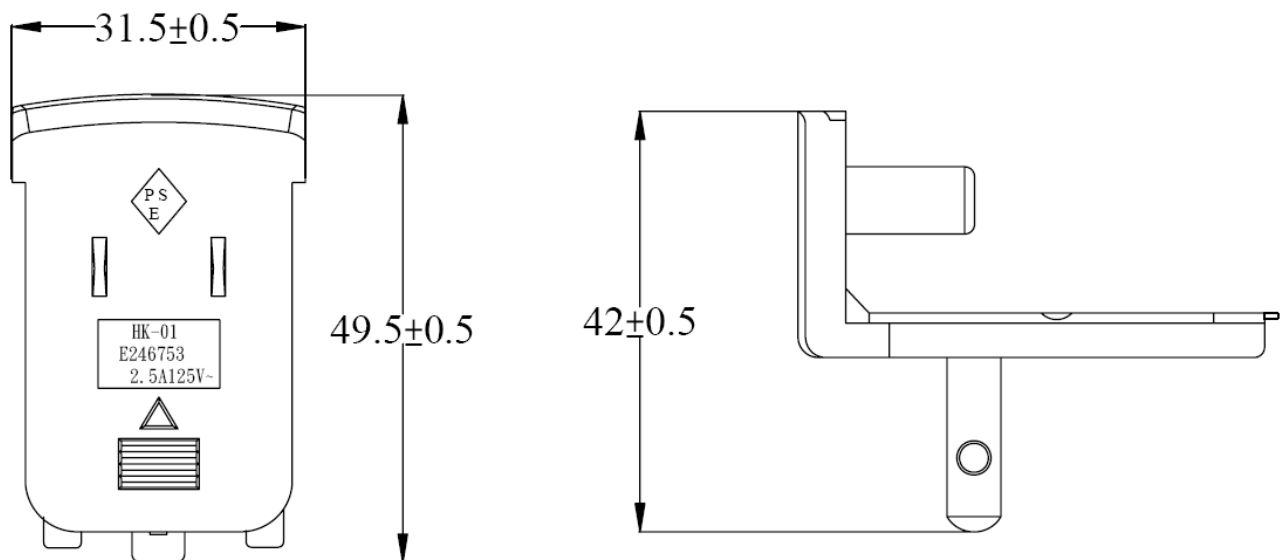

MODEL NO. :	UL轉換頭	PAGE NO. :	3 OF 3
PART NO. :	HKSC-100998	ISSUED DATE:	2011.12.01
DESCRIPTION :		REV:	(A0)

UNIT: mm

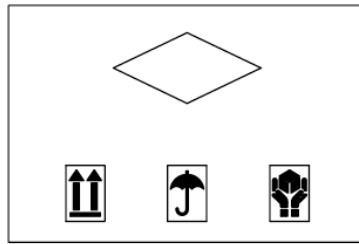

MODEL :
N. W. :
G. W. :
Q' TY: 252PCS

	100V-120V
	200V-240V
	100V-240V

