

Physics Teaching Kit

With the Photon Physics Kit, your students will enter an entirely new world of experimentation and creativity. The kit includes a set of original teaching scenarios, accessories, as well as an intuitive dedicated app.



What's in the Kit:

-  x2 Photon Robot
-  2x Ruler
-  2x Harness
-  10x lesson scenarios
-  2x Tape measure
-  Weights (10 x 100g)
-  1x Magic Dongle
-  1x Stopwatch
-  Multi-colored base pads (2 sets)
-  2x Dynamometer
-  1x Flashlight
-  1x Magnifying glass
-  2x Caliper



Why Physics Kit?

Photon Physics Kit was created to introduce new methods of teaching physics and allow students to rediscover the subject. Physics, as well as many other sciences, is often considered boring and difficult when in reality it is simply taught wrong. Re-ignite your students' curiosity with a modern approach to this fascinating subject. The Kit includes a set of original lesson plans, accessories, as well as an intuitive dedicated app for mobile and desktop devices.



With the Physics Kit, your students will:

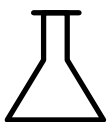

Understand physics through real-life experiments

The experiments and the attached teaching aids take the students way beyond the classic textbook-based lessons making physics exciting and easy to grasp.

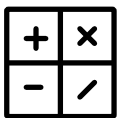

Improve their mathematical skills

Maths is an integral part of learning physics. The kit deftly combines mathematics and physics, while ensuring that students aren't bored and are eager to improve their mathematical skills along with the physical ones.



Develop logical thinking

The combination of theory and experimentation fosters logical thinking, which is crucial in overall academic performance.

Title and Key Concepts

Learning Outcomes

Units and Measurements

- SI System of Units
- measurement
- physical size
- units of measurement

- 1.** To learn key concepts and physical properties to help in observation, description, and provision of examples of physical phenomena in the natural world
- 2.** To be able to use information from the analysis of data from various sources, i.e. experiments, books, popular science texts.

How to Conduct Experiments

- measurement uncertainty
- significant figures

- 1.** To be able to distinguish the concepts of observation, measurement, and experiment; to perform observations, measurements and experiments by following instructions.
- 2.** To be able to describe a course of an experiment; to highlight key steps in a process and describe procedures; to understand the concept of measurement uncertainty; to be able to properly record results of any measurement and pay attention to units and inaccuracies.
- 3.** To be able to carry out calculations and record results, apply rounding rules and to understand the significance of decimal places (significant digits), inaccuracy of measurement, or data.

Force and Its Characteristics

- force
- newton
- vector quantity
- physical quantity

- 1.** To understand the concept of force as a directed action (a vector quantity); to be able to indicate the unit of force, magnitude, and direction of the force vector; to be able to properly use the unit of force.
- 2.** To recognize and name forces, give examples of them in various practical situations (gravity, pressure, elasticity, friction).

Motion and Its Relativity

- frame of reference
- path
- newton
- distance
- relativity of motion

- 1.** To describe and present examples of the relativity of motion.
- 2.** To understand the concepts of a path and distance.

Uniform Linear Motion

- speed
- uniform motion

- 1.** To be able to recognize an increase or decrease in values based on table data or graphs.
- 2.** To be able to recognize direct proportionality from a graph.
- 3.** To be able to recognize uniform linear motion, i.e. with constant velocity or zero acceleration in a period of time.
- 4.** To be able to determine velocity and distance from a distance-time graph and a velocity-time graph for uniform linear motion and to be able to draw such graphs from the provided information.

Title and Key Concepts

Learning Outcomes

Non–Uniform Motion

- instantaneous speed
- average speed
- acceleration
- uniform deceleration
- uniform acceleration

1. To understand special cases of non–uniform motion, i.e. motion uniformly accelerated and uniformly decelerated in equal intervals of time.
2. To understand the concept of acceleration to describe a non–uniform motion that is uniformly accelerated or uniformly decelerated.
3. To be able to calculate acceleration and use correct units.
4. To be able to calculate other values in the acceleration equation, i.e. change in velocity ($\delta v = a \cdot \delta t$), time taken.
5. To be able to calculate the change in velocity and acceleration from velocity-time graphs for nonuniform motion that is uniformly accelerated or uniformly decelerated.
6. To be able to convert units and subunits (micro–, milli–, centi–, hecto–, kilo–, mega–).
7. To be able to recognize an increase or decrease in values based on table data or graphs.
8. To be able to recognize direct proportionality from a graph.

Analysis of Graphs

- distance
- speed
- time

1. To be able to extract relevant or key information from texts, tables, diagrams, charts, schematics, or block diagrams about any phenomenon or problem being described; to present it in various forms.
2. To recognize increasing or decreasing dependencies based on table data or graph; to recognize simple proportionality by analyzing graphs.

Work, Power, Energy

- work
- power
- energy
- joule
- watt

1. To understand and use the concept of mechanical work together with the units of work; to be able to calculate work by multiplying the force by the distance on which it was performed.
2. To understand and use the concept of power together with the units of power; to be able to calculate power where work or energy is divided by the time it takes to do the work.

Sound Pitch and Volume

- sound volume
- sound pitch
- ultrasounds
- infrasounds

1. To be able to describe the formation of sound waves and their propagation through the air; to be able to provide examples of sound sources.
2. To be able to describe the relationship between sound pitch and wave frequency and the relationship between sound intensity (loudness) and the energy and amplitude of the wave.

Light Scattering and Reflection

- angle of incidence
- angle of reflection
- normal line
- light diffusion and focusing

1. To be able to describe the phenomenon of reflection from a flat surface and a spherical surface.
2. To be able to describe the phenomenon of light scattering, i.e. light reflected from a rough surface.
3. To be able to analyze light rays coming out of a point in different directions and then being reflected off a flat or spherical mirror.
4. To be able to describe the concentration of light rays in a concave mirror and light reflected from a convex mirror.
5. To properly use key terms: focus and focal length.

How to work with the Kit

We always recommend buying one Kit for 5-6 students. The more Kits in class, the more possibilities you get to conduct engaging classes.

The physical nature of the robot and the kit allows for exploring the world of physics through unconventional and exciting experiments, which in turn increases engagement and enhances learning. Teachers can introduce the concepts of uniform motion, force, work, energy, sound, light, and much more. Each student's work has a measurable impact on the entire team's result, which helps foster responsibility and teamwork skills.

Physics | Students aged 12–14

 45 minutes

Scenario: Units and measurements

Supplement to the core curriculum

Goals:

- To learn key concepts and physical properties to help in observation, description, and provision of examples of physical phenomena in the natural world.
- To be able to use information from the analysis of data from various sources, i.e. experiments, books, popular science texts.

Objectives:

Students:

- To be able to extract relevant or key information from texts, tables, diagrams, charts, schematics, or block diagrams about any phenomenon or problem being described; to present it in various forms.
- To be able to convert units and subunits (micro–, mili–, centi–, hecto–, kilo–, mega–).
- To be able to convert units of time (seconds, minutes, hours).

Required items:

- Two Photon robots
- Desktop computer with Photon Magic Bridge application installed
- Spring scale
- Tape measure
- Caliper
- Ruler

Key concepts:

- SI System of Units
- measurement
- physical size
- units of measurement

Introduction

Revision of knowledge about the units of length, weight, and time used in everyday life situations and methods of their measurement – see Attachments with pictograms.

Smartphone – 14 dag

Soccer game – 90 min

Safety Match – 40 mm

Elephant – 6 tons

Candy – 10 g

Dog – 15 kg

Lesson – 2700 s

Sample questions:

Do we use the same units to weigh a dog, candy, or an elephant? Why do we use different units of weight for different things? Do people around the world use the same systems of measurement? What are the consequences of using different measurement units?

Learning activity

On your projector screen present the diagrams of the robot – front and side view. Ask students to measure the actual dimensions of specific robot parts (indicated on the diagram) and enter the results in their worksheets.

Provide students with several measuring tools – a ruler, a tape measure, a caliper. In case of problems, instruct them which tools to use. After taking the measurements, ask students for units of measurements used in their measuring results. Optionally, write down several measurement results from different students on a blackboard. Unlock and show a selected column with dimensions. Together, check that all measurements are correct, point out any inaccuracies and reasons for them.

Instruct students to complete the rest of the table. Later, present the correct values and together with the class, check if they match the ones proposed by the students. After completion of the dimensions table, ask students to guess the robot's weight. Then allow them to weigh it using a spring scale or a regular scale and complete their worksheets. In the end, ask them to convert this weight into various metric units.

Discussion topics

- Why do we need Systems of measurement, such as the International System of Units (SI)?
- What units were used in the past?

Interesting facts

- The First General Conference on Weights and Measures of 26 September 1889 established the definition of a meter at a temperature of 0° Celsius and normal air pressure between the axes of the two central lines marked on a bar made of platinum-iridium. It has been deposited with the International Bureau of Weights and Measures (BIPM) in Sèvres near Paris, together with its written definition and a standard for a kilogram: https://en.wikipedia.org/wiki/General_Conference_on_Weights_and_Measures
- The BIPM website: <https://www.bipm.org/en/about-us/>

Worksheet

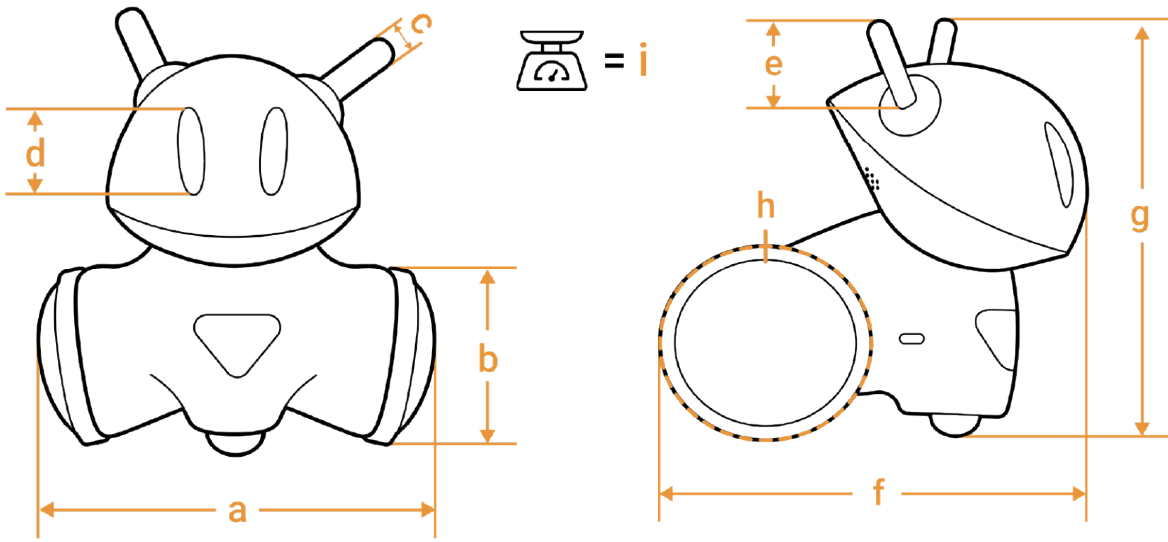

		millimeters	centimeters	decimeters	meters	kilometers
a	width					
b	tire diameter					
c	ear thickness					
d	eye height					
e	ear length					
f	length					
g	height					
h	tire circumference					

Total weight of the Photon robot (i): _____ kg = _____ dag = _____ g = _____