

承認書
APPROVED DATA

客 戶
CUSTOMERS

RAPID ELECTRONICS LTD

品 名

DESCRIPTION: AC SOCKET

力 瑋 料 號

INALWAYS P/N: 0712-PQ (of 0712 Series)

客 戶 料 號

CUSTOMER P/N: 23-0372

日 期

DATE 2013 年 6 月 7 日

承 認 印 APPROVED BY



TITLE : AC INLET / OUTLET 3P SOCKET

Part No. : 0712 Series

TABLE OF CONTENTS

1. Scope 應用範圍
2. Electrical Ratings 額定電流/電壓
3. Materials and Construction 材質與結構
 - 3.1 Materials 材質
 - 3.2 Construction 結構
 - 3.3 Operating Temperature 工作溫度
 - 3.4 Performance and Procedures 性能及程序
4. Test Requirement and Procedures 測試條件及程序
5. Test Sequences 測試順序
6. Certified Safety 認證安規
7. Manufacturing Location / Factory 生產地/工廠



DOCUMENT NO.	REV	DESCRIPTION	APPROVED BY	CHECKED BY	WRITTEN BY	DATE (yyyy/mm/dd)	SHEET NO.
E712-1001	A	NEW RELEASE				2010/11/04	1 OF 7



1. Scope 應用範圍

This specification applies to AC Inlet / Outlet 3P Socket for case mount of the following rated for Cold condition, for class I equipment only, in accordance of IEC 60320-1, EN 60320-1, IEC 60320-2-2, EN 60320-2-2, UL 498 and CSA C22.2. The pins temperature should not exceed to 70 °C.

本規範適用於冷環境一級設備之3P插座，依照 IEC 60320-1、EN 60320-1、IEC 60320-2-2、EN 60320-2-2、UL 498 及 CSA C22.2等規範，插座內插梢之溫度不可超過 70 °C。

2. Electrical Ratings 額定電流/電壓

EUROPE 歐洲： 10 A 250 VAC

NORTH AMERICA 北美： 15 A 250 VAC

3. Materials and Construction 材質與結構

3.1 Materials 材質

Frame： Thermoplastic, Nylon 66, UL 94V-0 架構：熱塑性塑膠、尼龍 66

Pin & Terminals： Copper alloy, Tin plated 插梢 & 端子：黃銅，鍍錫

3.2 Construction 結構

See the figure. 見附圖

3.3 Operating Temperature 工作溫度

-25 °C to +70 °C

3.4 Performance and Procedures 性能及程序

Socket shall be designed to meet the electrical, mechanical and environmental performance requirements specified in 4.

插座必須設計滿足電氣、機械及環境測試性能需求，詳細規格說明於 4. 節。

TITLE	AC INLET / OUTLET 3P SOCKET			
DOCUMENT NO.	REV	DESCRIPTION	DATE (yyyy/mm/dd)	SHEET NO.
E712-1001	A	SEE SHEET 1	2010/11/04	2 OF 7



4. Test Requirement and Procedures 測試條件及程序

Electrical Requirements 電氣特性要求		
Item	Requirement	Test Methods
Insulation Resistance 絕緣阻抗	100 M Ω min. 100 M Ω 以上。	500 VDC applied for one minute between adjacent terminals and between adjacent terminals and housing. 測試電壓500 VDC、測試時間1分鐘，在端子與端子間及端子與本體間。 IEC 60320-1, Section 15
Electric Strength 耐電壓強度	No Breakdown. 無任何損壞。	A) 2,000 VAC being applied between all terminals for one minute. After normal operation test voltage reduced to 1500VAC. 在端子與端子之間施加 2,000 VAC 測試 1分鐘。正常操作後測試電壓降至1500 VAC。 B) 4,000 VAC being applied between terminal and frame for one minute. 在端子與塑膠本體之間施加 4,000 VAC 測試 1分鐘。 IEC 60320-2-2, Section 15
Contact Resistance 接觸阻抗	30 m Ω max. 30 m Ω 以內。	Mate connectors, apply maximum voltage of 5 V and a current of 100 mA. 將連接器匹配後，以測試電壓最大5 V，電流最大100 mA。 IEC 60127-6
Breaking capacity 切斷容量	No damage. 無任何損傷。	The specimen shall be connected and disconnected 50 times/ 1.25 times rating current, at a rate of 30 strokes per min. The test voltage is 275V, and the power factor is 0.95. 樣品以1.25倍額定電流插拔50次，速度每分鐘15次、測試電壓為275V、功率因素0.95。 IEC 60320-2-2, Section 19
Temperature Rise 溫昇	Temperature rise less than 45 $^{\circ}$ C. 溫昇小於45 $^{\circ}$ C。	An alternating current 1.25 times rating current is passed through the specimen for 1 hour. 樣品施加1.25倍之額定交流電流測試1小時。 IEC 60320-2-2, Section 21

TITLE	AC INLET / OUTLET 3P SOCKET			
DOCUMENT NO.	REV	DESCRIPTION	DATE (yyyy/mm/dd)	SHEET NO.
E712-1001	A	SEE SHEET 1	2010/11/04	3 OF 7



4. Test Requirement and Procedures 測試條件及程序

Mechanical Requirements 機械特性要求		
Item	Requirement	Test Methods
Pull Force of Terminal 端子推出力	No movement exceeding 2.5 mm. 移動 2.5 mm以下。	The specimen shall be heated to temperature of 70 °C for 1 hour. Then a static load of 60 N (6.12 kgf) is applied to the pins for one minute. 加熱樣品至70 °C維持 1小時，然後施加 60 N (6.12 kgf)於插梢持續 1分鐘。 IEC 60320-1, Section 13
Ball-Pressure Test 球壓測試	Measure the diameter of the impression shall not exceed 2 mm. 壓痕直徑最大 2 mm。	The specimen shall be stored at a temperature of 125 ± 2 °C, a steel ball of 5 mm diameter is pressed against the surface of the specimen with a force of 20 N(2.04 kgf) for 1 hour. 產品放在 125 ± 2 °C的加熱室內，用一直徑 5 mm的鐵球、作用力20 N (2.04 kgf)，對產品表面施壓1小時。 IEC 60320-1, Section 24
Withdrawal Force 拔出力	10 ~50 N (1.02 ~ 5.10 kgf)	The specimen shall be inserted a mating connector then measure the force of withdraw. 樣品插入匹配之-連接器後量測拔出力。 IEC 60320-2-2, SECTION 16
Normal Operation 正常操作	No damage. 無任何損壞。	The specimen shall be inserted and disconnected 1,000 times/rating current, and 3,000 times without current flowing. 樣品施加額定電流插拔1000次；不施加電流插拔3000次。 IEC 60320-2-2, SECTION 20
Push-out Test 面板推出測試	Specimen cannot be push out from the panel. 樣品不會被推出面板。	The specimen shall be mounted on a panel, then apply a static load of 90N from the back of the specimen for one minute. 樣品固定在面板上，然後施加 90N於樣品背部持續1分鐘。

TITLE	AC INLET / OUTLET 3P SOCKET			
DOCUMENT NO.	REV	DESCRIPTION	DATE (yyyy/mm/dd)	SHEET NO.
E712-1001	A	SEE SHEET 1	2010/11/04	4 OF 7



4. Test Requirement and Procedures 測試條件及程序

Environment Requirements 環境特性要求		
Item	Requirement	Test Methods
Moisture Resistance 防潮	No damage. 無任何損傷。	Expose the specimens to 20 ~ 30 °C, 91 ~ 95 % R.H. for 168 hours. 樣品放在溫度20 ~ 30 °C、相對溼度91~95%之測試槽內168小時。 IEC 60320-1, Section14
Resistance to Heat 耐熱性	No damage. 無任何損傷。	The specimen shall be stored at a temperature of 100 ± 2 °C for 1 hour. 樣品放入100 ± 2 °C的測試槽內1小時。 IEC 60320-1, Section 24
Solderability 焊錫性	Solder coverage more than 90 %. 端子需披覆錫 90 % 以上。	A) Wave Soldering 波焊： Soldering temperature 250 ± 5 °C, duration 3~5 sec. 錫溫 250 ± 5 °C，沾錫3~5秒。 B) Manual Soldering 烙鐵焊接： Soldering temperature 380 ± 5 °C, duration 2~3 sec. 錫溫 380 ± 5 °C，焊接2~3秒。 IEC 60068-2
Resistance to Solder Heat 抗焊錫熱	No damage. 無任何損傷。	A) Wave Soldering 波焊： Soldering temperature 260 ± 5 °C, duration 5 ± 1 sec. 錫溫 260 ± 5 °C，沾錫 5 ± 1秒。 B) Manual Soldering 烙鐵焊接： Soldering temperature 400 ± 5 °C, duration 5 ± 1 sec. 烙鐵溫度 400 ± 5 °C，焊接 5 ± 1秒。 IEC 60068-2

TITLE	AC INLET / OUTLET 3P SOCKET			
DOCUMENT NO.	REV	DESCRIPTION	DATE (yyyy/mm/dd)	SHEET NO.
E712-1001	A	SEE SHEET 1	2010/11/04	5 OF 7



5. Test Sequences 測試順序

The test sequences are defined as following. 測試順序如下：

Test Description Sequence	Test Group			Supplemental Test
	1	2	3	
Insulation Resistance 絕緣阻抗	2			
Electric Strength 耐電壓強度	3, 8			
Contact Resistance 接觸阻抗	4			
Breaking Capacity 切斷容量	6			
Temperature Rise 溫昇	9			
Pull Force of Terminal 端子推出力		1		
Ball-Pressure Test 球壓測試		3		
Withdrawal Force 拔出力	5, 10			
Normal Operation 正常操作	7			
Push-Out test 面板推出測試		4		
Moisture Resistance 防潮	1			
Resistance to Heat 耐熱性		2		
Solderability 焊錫性			1	
Resistance to Solder Heat 抗焊錫熱		5		
Sample Size for Each Group	6	3	3	

6. Certified Safety 認證安規

UL / CSA / ENEC(16) / CCC

TITLE	AC INLET / OUTLET 3P SOCKET			
DOCUMENT NO.	REV	DESCRIPTION	DATE (yyyy/mm/dd)	SHEET NO.
E712-1001	A	SEE SHEET 1	2010/11/04	6 OF 7



7. Manufacturing Location / Factory 生產地 / 工廠

Inalways Electronic (DONGGUAN) Co. Ltd.

SiHuan Rd., XianXi, ChangAn, DongGuan, GuangDong Province, China

Tel: 86-769-8530-7001 Fax: 86-769-8530-7010

華瑋電子(東莞)有限公司

中國廣東省東莞市長安鎮咸西村四環路

Tel: 86-769-8530-7001 Fax: 86-769-8530-7010

Note:

If the Spec., Material, Manufacturing process & QA system of the product is changed at anytime, the acknowledgement of the quality & reliability data of the product will be provided to the Quality Dept. of customer ahead of time.

本產品之規格、材料、製程及品保系統有變更時，須事先將品質及信賴性確認數據，以書面方式向客戶之品保單位提出報備。

TITLE		AC INLET / OUTLET 3P SOCKET		
DOCUMENT NO.	REV	DESCRIPTION	DATE (yyyy/mm/dd)	SHEET NO.
E712-1001	A	SEE SHEET 1	2010/11/04	7 OF 7

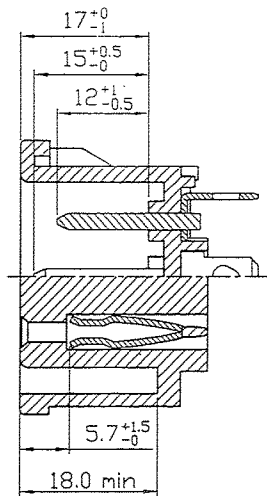
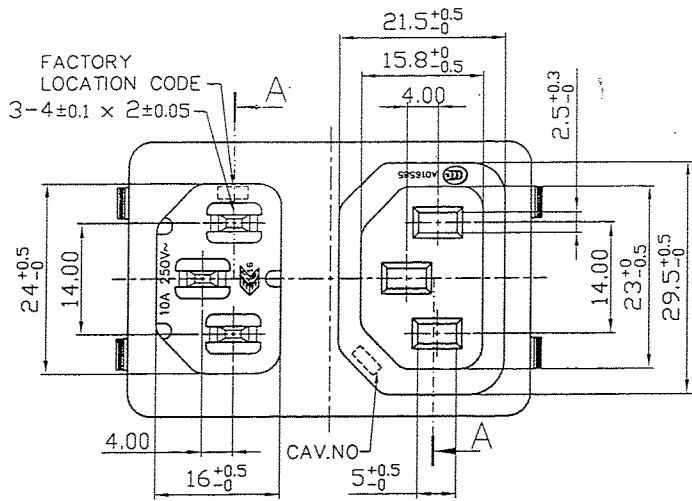

SECTION A-A

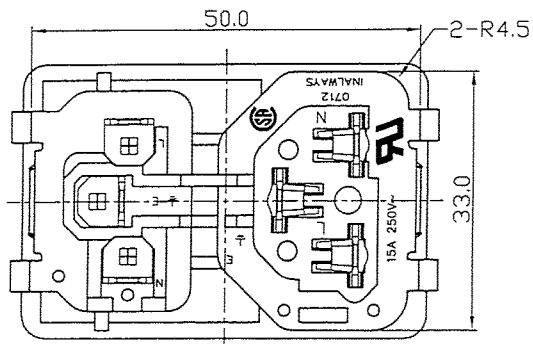
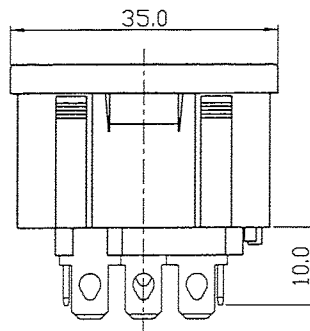
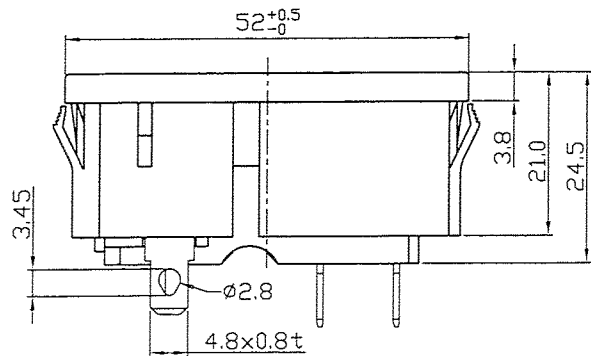

客戶用圖

SPECIFICATION

A: MATERIAL:

1. HOUSING: NYLON 66 FLAMMABILITY, UL 94V-0
2. TERMINAL: COPPER ALLOY, TIN PLATED

B: CHARACTERISTICS:

1. RATING: 15A 250V~ NORTH AMERICA
10A 250V~ EUROPE
2. INSULATION RESISTANCE: 100 MΩ MIN, AT 500 VDC
3. ELECTRIC STRENGTH: AC 2,000 V FOR ONE MINUTE

C: APPROVALS:

UL, CSA, ENEC & CCC

THICKNESS:

0.8~1.2t, X=50.5

1.3~2.0t, X=50.8

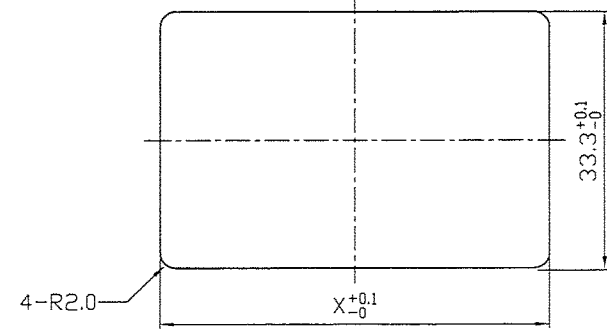

PANEL CUT-OUT

圖面管制中心

嚴禁 2013.6.07 複印

力瑋出圖章

發圖者: 李孟玲

E			
D			
C	2011.10.10	DGR11006	CHANGE SAFETY MARK
B	2007.10.25	DGR07055	DIM CHANGE
A	04-19-06	DGR06029	NEW REVISION
REV	DATE	DOCUMENT	DESCRIPTION

<p>力瑋實業股份有限公司 INALWAYS CORPORATION</p>	PART NO.:	0712-PQ	NAME:	AC INLET & OUTLET 3P (PUSH-IN)
	MATERIAL:	SEE ABOVE	SPEC.:	IEC 60320-1, C14 IEC 60320-2-2, F
TOLERANCE UNLESS OTHERWISE MARKED				
DIMENSION:	±3'			
ANGULAR:				
.000: ±0.1				
.00: ±0.2				
.0: ±0.3				
UNIT	SCALE	SHEET	APPROVED: [Signature] CHECKED: [Signature] DESIGNER: [Signature] NOTE:	
mm	1.5 : 1	1 of	2011-10-10 2011-10-10 2011-10-10	
			DOC.# S712-0003	



RTRT2.E101351 Receptacles for Plugs and Attachment Plugs - Component

[Page Bottom](#)

Receptacles for Plugs and Attachment Plugs - Component

[See General Information for Receptacles for Plugs and Attachment Plugs - Component](#)

INALWAYS CORP

E101351

7TH FL 105 WUGUNG RD
WUGU INDUSTRIAL DISTRICT
WUGU SHIANG
TAIPEI HSIEN, 24890 TAIWAN

Receptacles. Cat. Nos. 0709, 0710, 0715, 0716, 0719.

Cat. Nos. 0708-1, 0708-1-CP, 0718, 0718-1, 0718-2, 0723.

Cat. Nos. 0712-PS, 0712-PQ, 0712-PW, 0712-PP, 0712-PLSG, 0712-PQG, 0712-PLS.

Cat. No. 0728.

Inlet/Receptacles, Models 0911-1CQ, 0911-1PQ, 1521-1CQ, 1521-1PQ.

Marking: Company name and catalog or model designation on device or carton.

[Last Updated](#) on 2010-05-26

[Questions?](#)

[Print this page](#)

[Notice of Disclaimer](#)

[Page Top](#)

[Copyright](#) © 2011 Underwriters Laboratories Inc.®

The appearance of a company's name or product in this database does not in itself assure that products so identified have been manufactured under UL's Follow-Up Service. Only those products bearing the UL Mark should be considered to be Listed and covered under UL's Follow-Up Service. Always look for the Mark on the product.

UL permits the reproduction of the material contained in the Online Certification Directory subject to the following conditions: 1. The Guide Information, Designs and/or Listings (files) must be presented in their entirety and in a non-misleading manner, without any manipulation of the data (or drawings). 2. The statement "Reprinted from the Online Certifications Directory with permission from Underwriters Laboratories Inc." must appear adjacent to the extracted material. In addition, the reprinted material must include a copyright notice in the following format: "Copyright © 2011 Underwriters Laboratories Inc.®"

An independent organization working for a safer world with integrity, precision and knowledge.





CSA INTERNATIONAL

Certificate of Compliance

Certificate: LR 63196-7, -8

Contract No: 159542 (LR 63196)

Project: 1109998

Date Issued: October 3, 2000

Issued to: Inalways Corporation
No. 58, Wu-Kung 5th Rd.,
Wu-Ku Industrial District,
Taipei Hsien, Taiwan

The products listed below are eligible to bear the CSA Mark shown

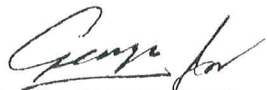

Issued by: Paul W. Chan, ASCT.
Vancouver, BC Canada

Signature: 

PRODUCTS

CLASS 6233 01 - RECEPTACLES - Attachment Plug Type and Plugs

Male inlets and outlet receptacles, Cat Nos as follows:

<u>Cat No</u>	<u>Configuration</u>	<u>Rating</u>	<u>Construction</u>
<u>Male Inlets:</u>			
0707	Sp23	10A, 250V	(1)
0707-1-XX, 0711, 0711-3, 0711-5, 0711-6 0714, 0714-1	Sp23	15A, 250V ac	(1)
	Sp23	15A, 125V	(1)
<u>Outlet Receptacles:</u>			
0708, 0708-1	Sp23	10A, 250V ac	(1)
<u>Cat No</u>	<u>Configuration</u>	<u>Rating</u>	<u>Construction</u>
0709	5-15R	15A, 125 V	(1)
<u>Combination Male Inlet/Outlet Receptacle:</u>			
0712	Sp23	15A, 250V ac	(1+1)

Suffixes: Suffixes may be added to the above catalogue numbers.

CERTIFICATE ENEC/FI 2010089



Our Ref. 260311-2b

Product Appliance outlet
Rating and principal characteristics 10 A, 250 V, IP20
Trade mark (if any) INALWAYS
Type 0712-.-... Series
Name and address of the licensee Inalways Corporation
 P.O. Box 17-196 Sinjhuang
 24899 TAIPEI COUNTY, TAIWAN
Address of the manufacturer Inalways Electronic (Dongguang) Co. Ltd.
 Si Huan Rd., Xianxi
 Changan Dongguan City
 GUANGDONG PROVINCE 523846, CHINA
Is in conformity with EN 60320-2-2:1998
 EN 60320-1:2001 + A1:2007

As shown in the Test Report(s) No(s) 260311-2b1 and 260311-2b22

It is authorized to use of the marks ENEC 16 and FI

Validity This certificate is valid until 01 October 2015 unless the standard in question has been amended or superseded with significant changes in requirements, in which case, SGS Fimko has the right to shorten the validity of the certificate based on the legislation of the European Union. This certificate includes the right to use the ENEC 16 and FI mark under the condition that changes (if any) will be checked at SGS Fimko before the product is brought onto market and that the conditions for ENEC and FI certification are met.

Directive information The product(s) fulfils the essential safety requirements for CE conformity marking according to the Low Voltage Directive (2006/95/EC) at the date of issue of this certificate.

With the following limitations -

Date of issue 01 October 2010

Signature
SGS Fimko Ltd

 Sixten Löfkors
 Project Manager



This certificate has 2 pages



This certificate is issued by the company under its General Conditions for Certification Services accessible at www.sgs.com/terms_and_conditions.htm. Attention is drawn to the limitations of liability defined therein and in the Test Report here above mentioned which findings are reflected in this certificate. Any unauthorized alteration, forgery or falsification of the content or appearance of this document is unlawful and offenders may be prosecuted to the fullest extent of the law.

Page No.: 2 of Certificate No.: FI/ENEC 2010089

Additional information

0712-... Series

- Combination appliance inlet - appliance outlet
- Standard sheet C14 see details on test report 260311-2b1 page 19
- Standard sheet F see details on test report 260311-2b22 page 17

Manufacturing site(s)

Inalways Electronic (Dongguan) Co. Ltd.
Si Huan Rd., Xianxi
Changan Dongguan City
GUANGDONG PROVINCE 523846, CHINA





CERTIFICATE FOR CHINA COMPULSORY PRODUCT CERTIFICATION

No. : 2003010204074308

NAME AND ADDRESS OF THE APPLICANT

INALWAYS ELECTRONIC (DONGGUAN) CO., LTD.
Si Huan Rd., Xianxi, Changan, Dongguan

NAME AND ADDRESS OF THE MANUFACTURER

INALWAYS ELECTRONIC (DONGGUAN) CO., LTD.
Si Huan Rd., Xianxi, Changan, Dongguan

NAME AND ADDRESS OF THE FACTORY

INALWAYS ELECTRONIC (DONGGUAN) CO., LTD.
Sihuan Road, Xianxi Village, Chang'an Town, Dongguan

NAME, MODEL AND SPECIFICATION

10A 250V Appliance Inlet for Class I Equipment for Cold Conditions +
10A 250V APPLIANCE OUTLET FOR CLASS I EQUIPMENT
0712 10A 250V~

THE STANDARDS AND TECHNICAL REQUIREMENTS FOR THE PRODUCTS

GB17465.1-2009 GB17465.2-2009

This is to certify that the above mentioned products have met the requirements of implementation rules for compulsory certification(REF NO. CNCA-01C-006:2011).

Date of issue: Aug.26,2011 Date of expiry: Aug.26,2016

Validity of this certificate is subject to positive result of the regular follow up inspection by issuing certification body until the expiry date.

Date of original certification: Aug.04,2003

This certificate can be verified through CNCA's website: www.cnca.gov.cn



President:

Wang Kejiao

CHINA QUALITY CERTIFICATION CENTRE

Section 9, No.188, Nansihuan Xilu, Beijing 100070 P.R.China

<http://www.cqc.com.cn>



Q 0454920

 華瑋電子(東莞)有限公司 出貨檢驗規範							核准	審核	制作			
客戶名稱	RAPID		產品名稱	AC SOCKET		文件編號	郝哲菊	吳宗亮	宇路			
客戶料號	/		華瑋料號	0712-PQ		文件版本						
抽樣標準	MIL-STD-105E單次正常II級抽樣		允收水準	CR = 0	MA = 0.1	MI = 0.25				客制編號		
檢驗項目	檢驗內容						缺點類別			檢驗方式 / 允收標準	判定	
							CR (嚴重)	MA (主要)	MI (次要)			
1. 紙箱外觀、料號、數量與箱麥確認	<input type="checkbox"/> 紙箱表面不可有壓垮、變形或破損、水漬、碰撞損壞							V		目視		
	<input type="checkbox"/> 出貨數量與出貨單數量須相符，箱麥標示需正確							V		目視 / 點數		
	<input type="checkbox"/> 出貨標籤之客戶料號、料號與送貨單資料及實物相符							V		目視		
2. 產品外觀檢測	<input type="checkbox"/> 主面外觀：射料不足、塑膠破損、髒污異色、毛邊、結合線、削傷、撞傷							V		目視		
	<input type="checkbox"/> 次表面外觀：射料不足、塑膠破損、髒污異色、毛邊、結合線、削傷、撞傷							V		目視		
	<input type="checkbox"/> 端子錯置 <input type="checkbox"/> 端子壓垮 <input type="checkbox"/> 端子漏植 <input type="checkbox"/> 端子未定位 <input type="checkbox"/> 端子晃動 <input type="checkbox"/> 端子漏加壓 <input type="checkbox"/> 卡鉤拉歪 <input type="checkbox"/> 卡鉤斷裂						V			目視		
	<input type="checkbox"/> 線材鉤焊端需完全包覆不可裸露或破損，松脫						V			目視		
	<input type="checkbox"/> 線材絕緣皮層不可破損，刮傷						V			目視		
	<input type="checkbox"/> 熱縮導管需熱縮到位							V		目視		
3. 尺寸檢驗(mm)	檢驗編號	尺寸規格	Cav#_	Cav#_	Cav#_	Cav#_	Cav#_	Cav#_	Cav#_	Cav#_	檢驗方式 / 允收標準	判定
	1	14.00±0.2									工程圖面	
	2	4.00±0.2									工程圖面	
	3	24+0.5/-0									工程圖面	
	4	16+0.5/-0									工程圖面	
	5	14.00±0.2									工程圖面	
	6	4.00±0.2									工程圖面	
	7	29.5+0.5/-0									工程圖面	
	8	21.5+0.5/-0									工程圖面	
	9	12+1/-0.5									工程圖面	
	10	15+0.5/-0									工程圖面	
										工程圖面		
										工程圖面		
										工程圖面		
										工程圖面		
										工程圖面		
										工程圖面		
4. 耐電壓&絕緣阻抗測試(依承認書測試條件)										高壓測試儀		
5. 扭力測試										<input type="checkbox"/> 扭力規格: 8kgf-cm <input type="checkbox"/> 特殊規格: _____ kgf-cm <input type="checkbox"/> N/A		
6. 拔出力測試										<input type="checkbox"/> SHEET F(10A): 全PIN最大50N，單PIN最小1.5N <input type="checkbox"/> SHEET J(16A): 全PIN最大60N，單PIN最小2N <input type="checkbox"/> N/A		
7. 膜厚測試	<input type="checkbox"/> 測試 <input type="checkbox"/> N/A									<input type="checkbox"/> 電鍍規格: 打銅底2.5um以上，鍍錫3.0um以上 <input type="checkbox"/> 電鍍規格: 打銅底2.5um以上，鍍錫3.0um以上 <input type="checkbox"/> 電鍍規格: 打銅底2.5um以上，鍍霧錫3.0um以上		
8. 刻字檢驗(Rating、料號、極性接地標示、INALWAYS Logo、認證安規標志、模具編號...).										目視		
9. 其它: _____												