



brennenstuhl®

Operating manual

RCS 1000 N / GB Comfort Remote control set

SAFETY

Intended use

The devices which constitute this RF remote control switch set are intended only for personal use in closed dry rooms. They are not suitable for commercial use.

The RF remote control switch set is used for switching lamps and electrical appliances on and off.

The devices may only be operated individually. Do not plug multiple socket switches into each other.

Any other use is considered non-intended use. The manufacturer assumes no liability for damage caused by non-intended use.

Operating manual



Read this operating manual through thoroughly before using the device. Keep the operating manual in a safe place. Should you pass on this device to another party be sure to include the operating manual.

Basic safety instructions

- Children are not aware of the dangers that may arise from improper handling of electrical devices. Never allow children to use electrical devices without supervision.
- Risk of suffocation! Do not leave the packaging material lying around. Children could swallow the small parts and choke on them.
- Plug the socket switches into conventional 3-pin UK sockets only.
- Do not connect the socket switches to extension cables. Only
- connect consumers which do not exceed the performance limits of the socket switches.
- Do not connect consumers (for example irons) which could cause fire or other damage if they are accidentally switched on.
- Do not connect consumers (for example refrigerators) which require condenser motors.

- Do not cover the socket switches. Heat builds up under the cover. This poses a fire hazard.
- Regularly check the devices for damage. Do not replace damaged parts. Contact the manufacturer or dispose of the devices in an environmentally friendly manner.
- Do not touch the devices with wet hands.
- To de-energise the socket switches disconnect them from the mains supply.

Batteries must be handled with particular care.

- Risk of explosion! Do not try to recharge non-rechargeable batteries.
- When the batteries are used up remove them from the battery compartment and dispose of them in an environmentally friendly manner.
- Do not throw batteries into fires and never subject them to high temperatures.
- Do not open or short-circuit batteries.
- Battery acid which leaks from a battery can cause skin irritations. In case of contact with skin rinse with plenty of water. Do not rub your eyes if any liquid gets in them; rinse them thoroughly with water and contact a doctor immediately.
- If you are not using the batteries remove them to avoid discharging.

WASTE DISPOSAL



Dispose of electrical devices in an environmentally friendly manner!

Electrical devices do not belong in the household rubbish. In accordance with European Directive 2002/96/EC on waste electrical and electronic equipment old power tools must be collected separately and sent to a proper recycling facility. You can find out more about the options for disposing of used devices from your local government or municipal authorities.



Risk of environmental damage from improper disposal of batteries!

Batteries do not belong in the household rubbish. They may contain poisonous heavy metals and must be treated as hazardous waste. For this reason, take used batteries to a local collection point.

DEVICE

Scope of delivery:

The following items are included in the scope of delivery:

- remote control with battery
- three socket switches.

Device overview

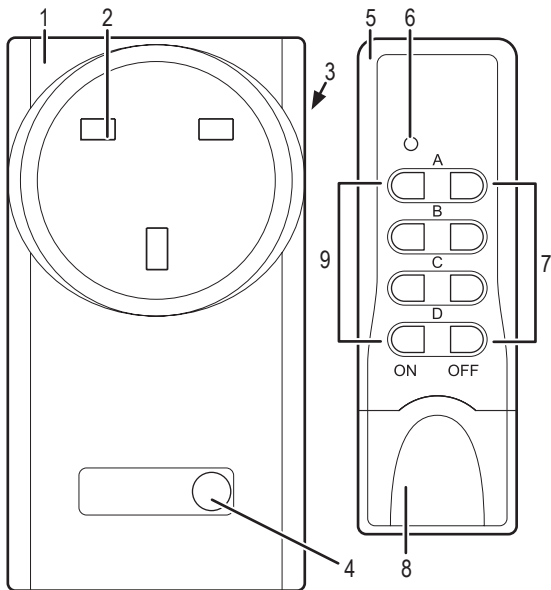

- | | |
|----------------------------|-----------------------------|
| 1 Socket switch | 6 Function indicator light |
| 2 Childproof socket | 7 OFF keys (A, B, C, D) |
| 3 UK plug | 8 Battery compartment cover |
| 4 Function indicator light | 9 ON keys (A, B, C, D) |
| 5 Remote control | |

Preparations

Before you can use the devices you must:

- insert the battery,
- synchronise the radio channels between the remote control and the socket switches and
- assign an ON/OFF key pair on the remote control to a socket switch.

Inserting the battery



Caution!

Observe the correct polarity of the battery. An incorrectly inserted battery can cause material damage.

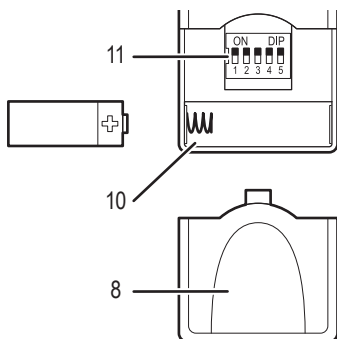

1. Remove the cover (8) of the battery compartment (10).
2. Insert the battery as shown in the figure.
3. Close the battery compartment (10).

4. Press any key on the remote control (5). The function indicator light (6) illuminates when the key is pressed.

i If the function indicator light (6) does not light up when a key is pressed the device is not receiving any power from the battery. Check whether you have inserted the battery correctly.

Synchronising the radio channels

Before using the devices for the first time the radio channels must be synchronised to enable all socket switches to react to the radio signal of the remote control.

Moreover, each socket switch must be assigned a frequency of a key pair on the remote control to enable it to be operated individually.

i Adjust the DIP switches using a suitable object, for instance a small screwdriver, by pushing them down or up.

Setting a radio channel on the remote control

1. Remove the cover (8) of the battery compartment (10).
2. Set a radio channel using DIP switches 1 to 5 (11).
3. Close the battery compartment (10).

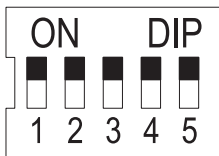

Setting a radio channel on the socket switch

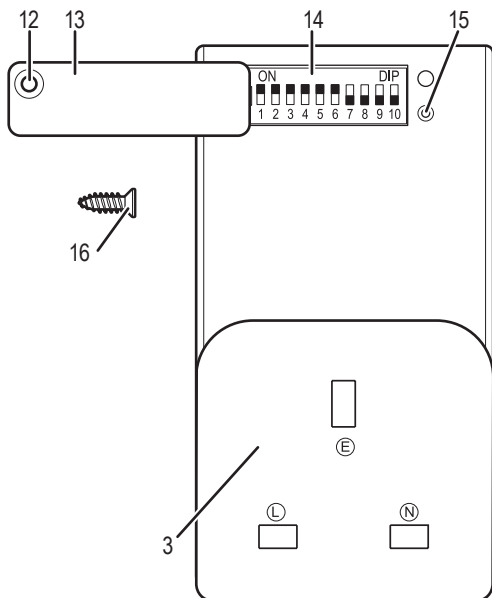

1. Undo the screw (16) of the cover (13) using a PH0 Phillips screwdriver.
2. Slightly raise the cover (13) above the screw hole (12) and push out.
3. Set the same radio channel as for the remote control using DIP switches 1 to 5 (14).

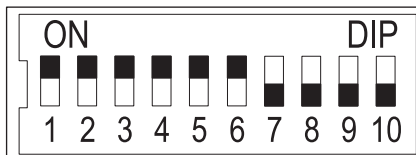

Assigning a socket switch to a control key

1. Set a frequency of a control key on the remote control using DIP switches 6 to 9 (14):



DIP switch 10 is not occupied.

Control key	DIP switch				
	6	7	8	9	10
A	ON	OFF	OFF	OFF	OFF
B	OFF	ON	OFF	OFF	OFF
C	OFF	OFF	ON	OFF	OFF
D	OFF	OFF	OFF	ON	OFF

2. Push the cover in (13) and close.
3. Insert the screw (16) through the screw hole (12) into the thread (15) and tighten.

Example

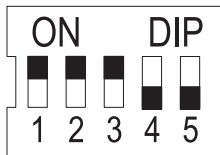

Set the radio channel '123' on the remote control.

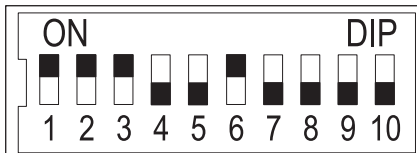

Set the radio channel '123' on all the socket switches. Set a control key frequency as well. In the figure the key pair 'A' is set with DIP switch 6.

Connecting the devices

The remote control radio signal has a range of up to 25 m (dependent on structural conditions).



The range can be affected by structural conditions (for example reinforced concrete), electrical conditions (for example electrical lines) or electromagnetic conditions (for example telephones). If necessary remove the source of interference or maintain a sufficient distance to the source of interference.

To connect the socket switches:

- plug the socket switches into sockets.

To connect the remote control:

- insert the battery into the battery compartment (10).

OPERATION

Switching on a socket switch

1. Plug the socket switch (1) into a socket.
2. Plug the consumer unit into the socket (2).
3. Press the preset ON key (9), for example 'A', to switch on the socket switch (1).

The function indicator light (6) illuminates whenever a key is pressed. The function indicator light (4) illuminates.

Switching off a socket switch

1. Press the preset OFF key (7), for example 'A', to switch off the socket switch (1).

The function indicator light (6) illuminates whenever a key is pressed. The function indicator light (4) goes out.

CLEANING



Caution! Risk of electric shock.

Before cleaning the device disconnect it from the mains supply.



Caution! Risk of electric shock.

Ensure that no liquid penetrates into the device. Liquid which enters the device can cause short-circuiting.



Caution! Risk of damage from aggressive cleaning agents.

Never use aggressive or abrasive cleaning agents for cleaning. Clean the device with a soft damp cloth and a mild cleaning agent.

Ensure that the device is completely dry before using it again.

MAINTENANCE

Check the battery regularly for damage.

TECHNICAL DATA

Operating voltage	240 VAC 50 Hz, British standard
Switching voltage	240 VAC 4,17 A
Socket switch switching power	max. 1000 W
Radio signal range	max. 25 m
Operating frequency	433.92 MHz
Ambient temperature	0°C to 35°C
Storage temperature	-40°C to 70°C
Battery	12 V, type A 23
CE-compliant	

TROUBLESHOOTING

Fault	Possible cause	Remedy
Function indicator light (4) does not light up when a key is pressed.	Battery has been inserted incorrectly.	Insert battery correctly.
	There is no battery contact.	Press down on the battery terminals.
	Battery is empty.	Insert new battery.
Function indicator light (6) does not light up.	Socket switch has not been connected correctly.	Push the socket switch firmly into the socket.
Function indicator light (6) lights up, but consumer does not work.	Consumer has not been switched on.	Switch on the consumer.
Socket switch does not switch on.	Radio channel of the socket switch has not been set correctly.	Set the radio channel of the remote control on the socket switch.
	Range between remote control and socket switch is insufficient.	Reduce the distance between the remote control and the socket switch.
	Electrical devices are causing interference.	Remove possible sources of interference.

WARRANTY

Warranty valid for 2 years from date of purchase. Please retain your sales receipt as proof of purchase. The warranty covers material and manufacturing defects only, not wear parts or damage resulting from improper use. Any intervention by a third party will void the warranty. Your legal rights are not restricted by this warranty. Should you wish to make a claim under the warranty please contact our Service Hotline. Only then can your device be returned free of charge. The original warranty period shall not be extended by repair or replacement of parts.

MANUFACTURER

H. Brennenstuhl GmbH u. Co. KG

Seestraße 1-3

72074 Tuebingen

Germany Email: info@brennenstuhl.de