

# Datasheet

Item no. 1586520

V1\_0617\_02\_EN

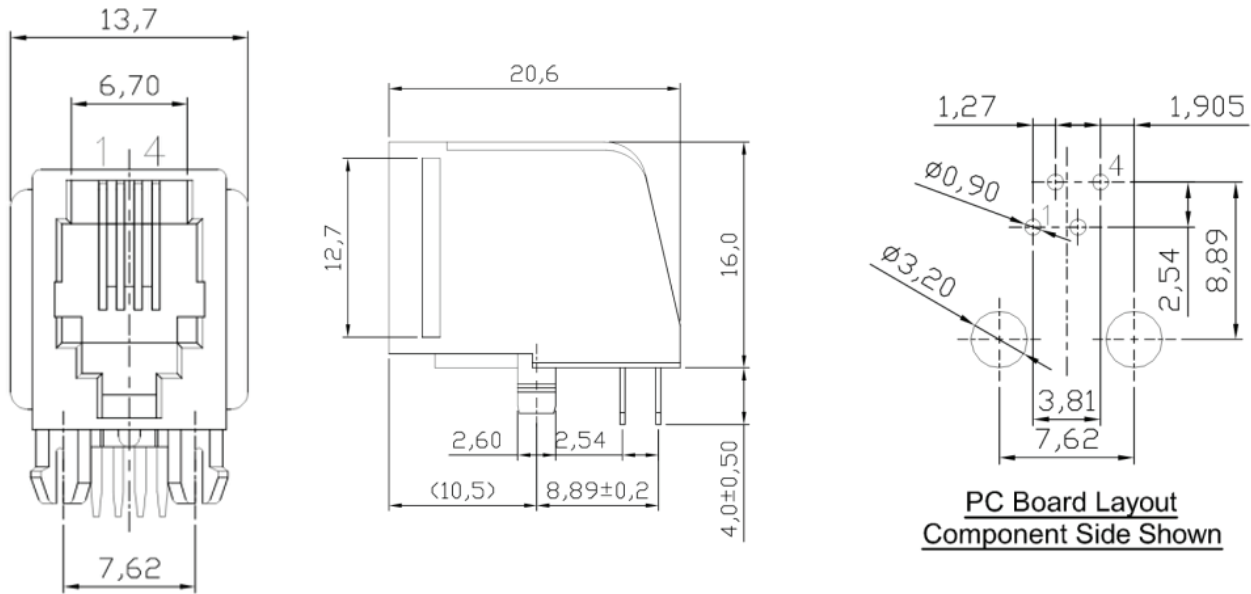

**PC Board Layout**  
**Component Side Shown**

**NOTES:**

**Mechanical:**

1. Housing material : Glass Filled Polyester UL94V-0 , Color: Black
2. Contact material: Phosphor Bronze  $t=0.35\text{mm}$
3. Contact plating: 6u" Gold on contact area  
100~200u" Tin on solder area  
all over 30~50u" Nickel
4. Operating Life: 750 Cycles min.
5. PCB Retention Pre-solder: 1 LB min.
6. PCB Retention Post-solder: 10 LBS min.

**Electrical:**

1. Voltage Rating: 125VAC.
2. Current Rating: 1.5AMP.
3. Contact Resistance: 50m $\Omega$  max.
4. Insulation Resistance: 500M $\Omega$  min. @ 1000 VDC
5. Dielectric Strength: 1000 VAC RMS 60Hz, 1 min.

**Environmental:**

1. Storage: -40°C To +85°C
2. Operation: -40°C~+85°C
3. Wave Soldering Temp: 200~220°C(5~10S)

Packing: 120pcs/Tray, 2640pcs/Carton



File No.: E345352

**RoHS compliant**

Unit:mm

