

### Top View of Assembly

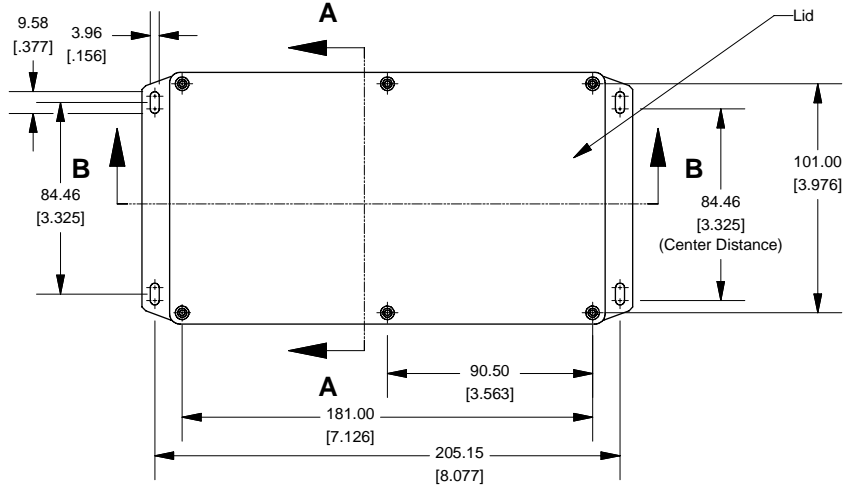

### SECTION A-A End View of Assembly

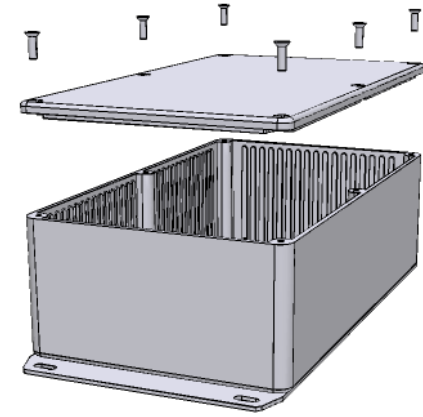
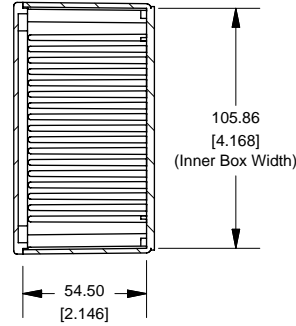

### SECTION B-B Side View of Assembly

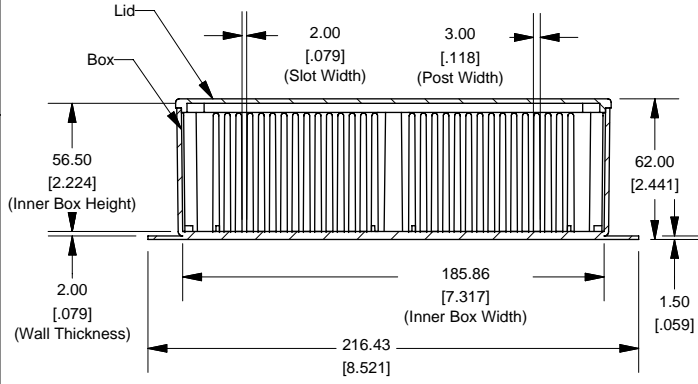

### Top View Looking Inside Box

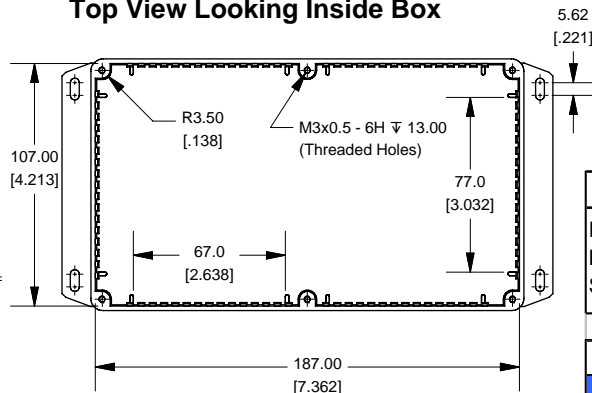

Enclosures can be Factory Modified ( Milling, Drilling, Printing etc.)  
 Contact Factory [mjm@hammondmgf.com](mailto:mjm@hammondmgf.com) for quotes  
 Solid models of this enclosure available in STEP or IGES.

#### NOTE

Purchased assembly includes box, lid and 4 cover screws.  
 Box and lid are made from Diecast Aluminum Alloy (alloy type 380).  
 Silicone Gasket Loctite #5950

#### PART NUMBERS

##### 1590RF Enclosure

Unfinished	1590RF
Grey Textured Polyester Powder Paint - RAL 7038	1590RFGY
Black Textured Polyester Powder Paint - RAL 9011	1590RFBK

#### ACCESSORIES

Recommended Torque: 75 ozf.in / 55 cNm

Unfinished Cover Screws (Pkg 100) [M3 - 0.5 x 10mm Nickel Plated Screws]	1591MS100
Black Textured Cover Screws (Pkg 100) [M3 - 0.5 x 10mm Nickel Plated Screws]	1591MS100BK

#### Lid

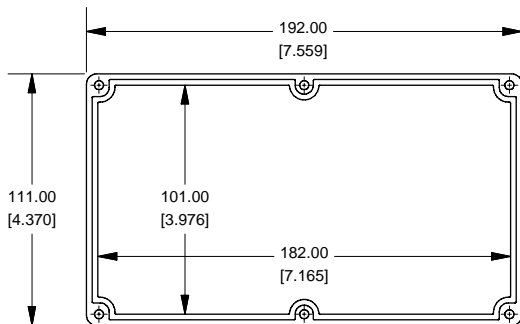

#### DETAIL D Interior Features

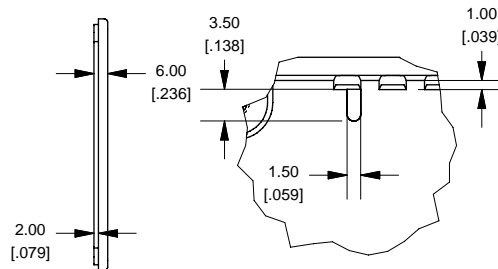

**HAMMOND  
MANUFACTURING™**

1590RF

[www.hammondmgf.com](http://www.hammondmgf.com)