

Nuts Screws Washers and Bolts

Order code	Manufacturer code	Description
33-4100	n/a	100 S/S M2.5 6MM PAN HD SCREWS
33-4105	n/a	100 S/S M2.5 12MM PAN HD SCREW
33-4110	n/a	100 S/S M2.5 20MM PAN HD SCREW
33-4115	n/a	100 S/S M3 6MM PAN HEAD SCREWS
33-4120	n/a	100 S/S M3 12MM PAN HEAD SCREW
33-4125	n/a	100 S/S M3 20MM PAN HEAD SCREW
33-4130	n/a	100 S/S M3 25MM PAN HEAD SCREW
33-4135	n/a	100 S/S M4 6MM PAN HEAD SCREWS
33-4140	n/a	100 S/S M4 12MM PAN HEAD SCREW
33-4145	n/a	100 S/S M4 20MM PAN HEAD SCREW
33-4150	n/a	100 S/S M4 25MM PAN HEAD SCREW

Nuts Screws Washers and Bolts	Page 1 of 2
The enclosed information is believed to be correct, Information may change 'without notice' due to product improvement. Users should ensure that the product is suitable for their use. E. & O. E.	Revision A 04/07/2003

Stainless Steel Pan Head Slotted Screws

A range of Pan Head Slotted, ISO metric, coarse threaded stainless steel screws. Resistant to corrosion, chemicals and heat. Applications include electronic, domestic, chemical and construction use, as well as in food and medical environments.

Meets the following - Standards / Specifications

DIN 85A 4.8 ISO 1580 SN 212424

Technical Specification

Material: Stainless Steel
 Resistance Class: 4.8
 Stress Resistance: min. 420 N/mm²
 Tensile Strength: min. 340 N/mm²
 Rupture Length: min. 14%

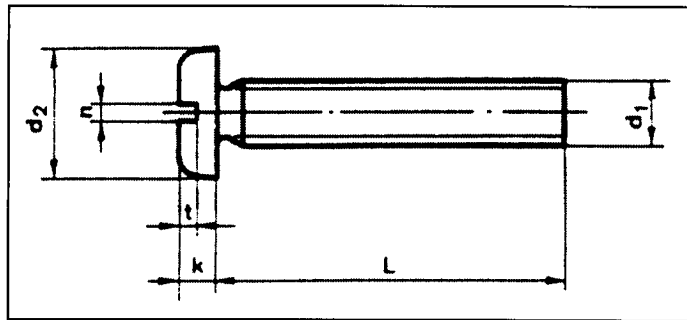

Thread Size (d ₁)	Screw Length (L)	Screw Dimensions (mm)			
		d ₂	k	n	t min.
M2.5	6 mm	5	1.5	0.6	0.6
M2.5	12 mm	5	1.5	0.6	0.6
M2.5	20 mm	5	1.5	0.6	0.6
M3	6 mm	6	1.8	0.8	0.7
M3	12 mm	6	1.8	0.8	0.7
M3	20 mm	6	1.8	0.8	0.7
M3	25 mm	6	1.8	0.8	0.7
M4	6 mm	8	2.4	1	1
M4	12 mm	8	2.4	1	1
M4	20 mm	8	2.4	1	1
M4	25 mm	8	2.4	1	1