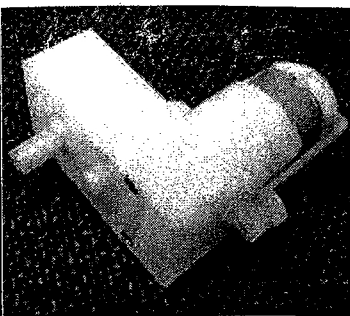

Valued customer 客戶名稱	同乐	Sample No. 樣板編號	BO222100073SR	
Model NO 機種型號	BO2	Date 日期	2010-4-17	
Gear ratio 齒比	1: 220	Specification No 規格書編號	BO222100073SR	

1.0 Conditions of Standard Operation 工作條件

- 1-1) Suggested Voltage 6.0 V DC Constant between motor terminals.
建議使用電壓 馬達端子電壓 6.0 V 直流恆壓。
- 1-2) Direction of rotation Bi-directions
回轉方向 雙向轉動
- 1-3) Gear box position All directions
牙箱放置狀態: 所有方向
- 1-4) Storage Humidity Range with the exception of gear box 30% ~70%
齒輪箱的存儲濕度範圍:
- 1-5) Operation temperature range with the exception of motor +10°C ~ +30°C
馬達除外零件的工作溫度範圍:
- 1-6) Storage Humidity Range with the exception of motor 10% ~70%
馬達除外零件的存儲濕度範圍:
- 1-7) Storage Humidity Range of motor 30% ~95%
馬達的存儲濕度範圍:

2.0 MEASURING CONDITIONS 測量條件

- 2-1) Gear box Position To be placed horizontally when measuring.
齒輪箱放置狀態 測試時水平放置
- 2-2) Power supply Regulated DC 6.0 V power supply
供電電壓 6.0 V 穩定直流電源

Prepared by: 呂志堅

Checked by: 湯貞彪

Approved by: 何永釗

GEAR BOX Specification (For Reference)

產品規格說明書(參考資料)

VERSION : 01

3.0.ELECTRICAL CHARACTERISTICS 電器特性

- 3-1) No Load Speed 36~58 rpm
無負荷轉速:
- 3-2) No load current : 150mA Max
無負荷電流
- 3-3) Allowable max. torque 2.7kgf.cm Min
容許最大扭力

4.0. MECHANICAL CHARACTERISTICS 機械特性

- 4-1) External Appearance: Attached outline Drawing:
外型尺寸 See DWG NO: _____ (Reference only)
- 4-2) Weight 30g
重量
- 4-3) Mechanical Noise: At no load operation with a distance of 100mm between the microphone and the motor is applied on the mechanical noise test:(motor rated voltage: 6.0V)
噪音 and the motor is applied on the mechanical noise test:(motor rated voltage: 6.0V)
Gear box noise: 73 dBA (max) Background noise: 37dBA(max)
牙箱噪音: 73 dBA (max) 環境噪音: 37dBA(max)

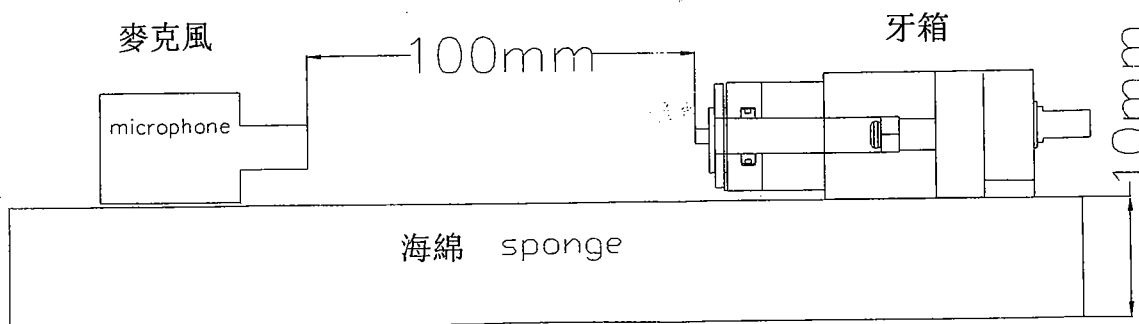

Prepared by : 吕志坚

Checked by : 汤贞彪

Approved by : 何永钊

5.0 Dimension 尺寸

Unit: mm

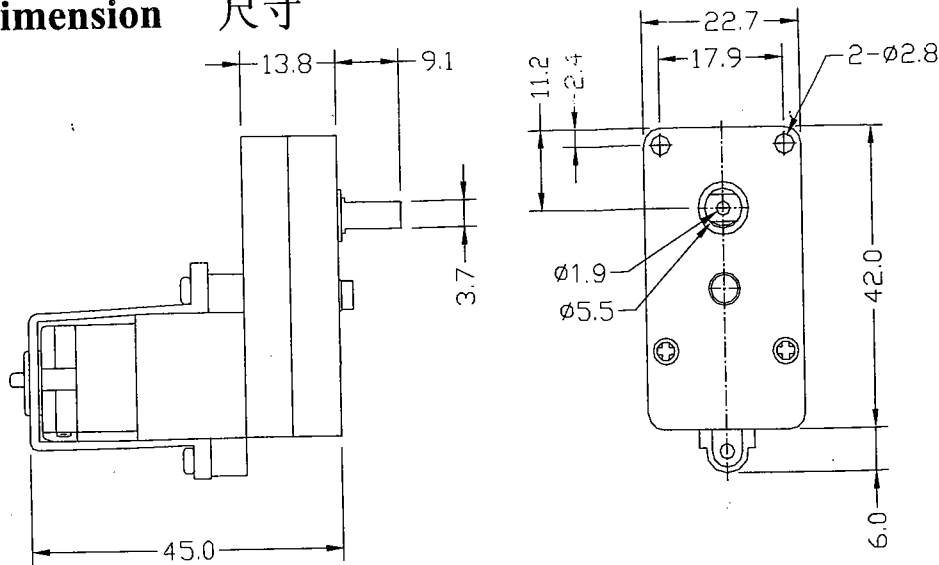

6.0 Assembly drawing :

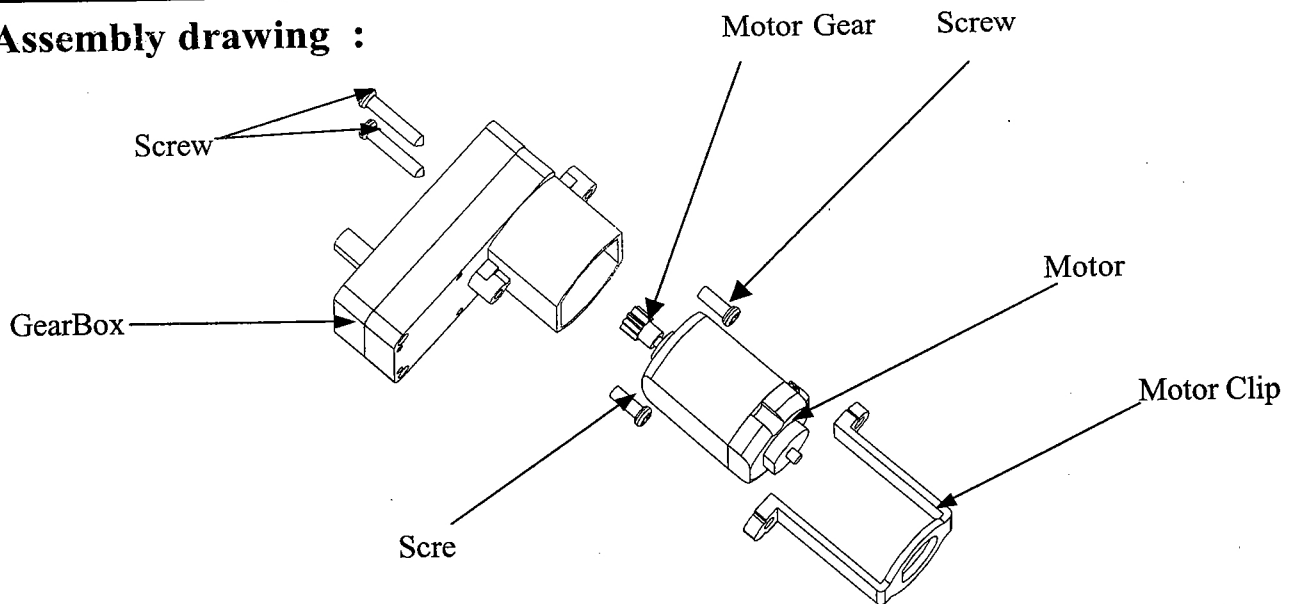

7.0 Part list:

Name 名稱	Number 數量	Material 材料	COLOR 顏色
Motor 馬達	1	Metal 金屬	NAT. 原色
Gears Box齒輪箱	1	P. O. M. 賽鋼	NAT. 原色
Motor Gear馬達齒	1	HYTREL軟膠	NAT. 原色
Motor clip馬達扣	1	ABS 苯乙烯共聚物	NAT. 原色
Screw 螺絲	4	Metal 金屬	NAT. 原色

Prepared by : 吕志坚

Checked by : 汤贞彪

Approved by : 何永钊