

29 MAY 2008

普耀集團有限公司
POLYSHINE HOLDINGS LTD

ENG. DEPT

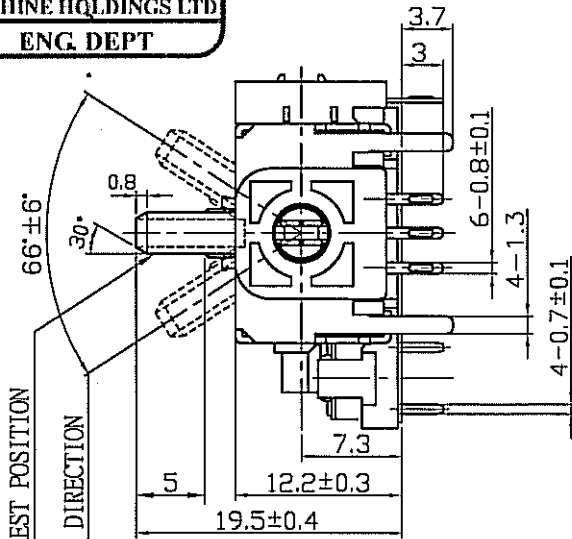
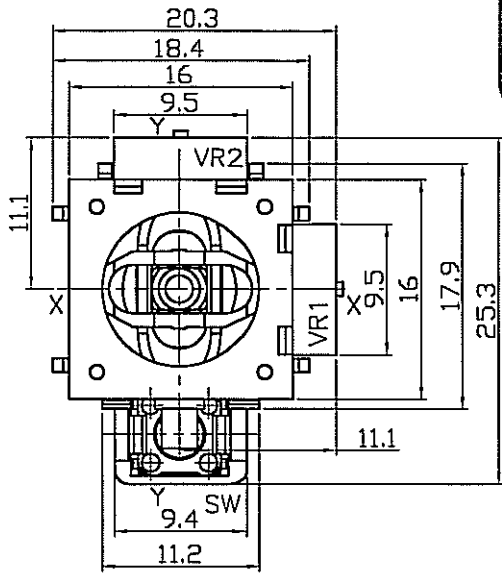

REST POSITION

X DIRECTION

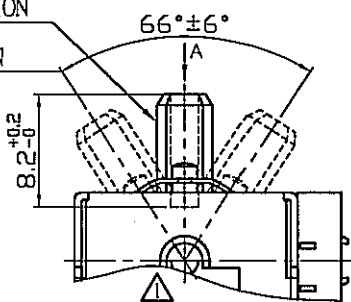

VIEW A

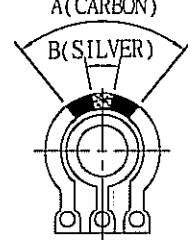
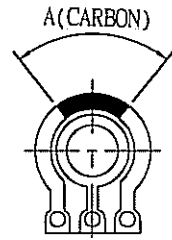
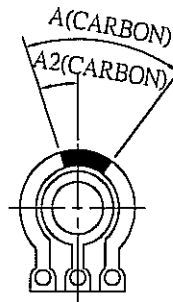
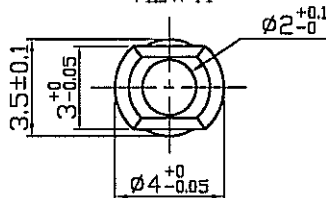

ANGLE		PART NO.	未指定容許±尺寸之公差		
A	A1				
25°	6°	12939-36	10以下	±0.3	
20°	3°	12939-23	10~100	±0.5	
ANGLE		PART NO.	100以上	±0.8	
A	A2				
25°	6°	12939-37	角度	±5°	
20°	3°	12939-24			
20°	0°	12939-21	ANGLE		
120°	40°	12939-2	A	B	PART NO.
35°	6°	12939-26	40°	3°	
147°	3°	12939-32	70°	6°	12939-33
28°	6°	12939-34	35°	8°	12939-35

ANGLE		PART NO.
A	C	
45°	5°	12939-28
40°	12°	12939-31
45°	12°	12939-25
38°	8°	12939-27
60°	5°	12939-29
ANGLE		PART NO.
A	B	
100°	8°	12939-14
80°	10°	12939-15
60°	10°	12939-16
25°	6°	12939-17

A	20°	28°	32°	38°	40°	50°	60°	70°	95°	180°	78°
	25°	30°	33.5°	35°	45°	53°	65°	90°	120°	300°	147°
ANGLE		PART NO.	ANGLE		PART NO.	ANGLE		PART NO.			
A	B		A	B		A	B				
60°	6°	12939-1	53°	6°	12939-6	45°	5°	12939-10			
38°	6°	12939-3	45°	3°	12939-7	30°	6°	12939-11			
38°	8°	12939-4	32°	3°	12939-8	50°	8°	12939-12			
50°	6°	12939-5	53°	8°	12939-9	85°	8°	12939-13			

普耀集團有限公司
POLYSHINE HOLDINGS LTD.

△			UNIT	SCALE	TITLE
△			MM	2 / 1	F-JP10K Series
△			DRAWN	DESIGN	DWG NAME
△			馮偉成	李凌斌	F-JP10K
△	2005.04.26	李凌斌	2004.12.01		DWG NO.
DEVISION	DATE	DESIGN			F-JP10K-08-001

一、ELECTRICAL CHARACTERISTICS 電氣特性

日期:2008 年 05 月 29 日

序號 NO.	項 目 ITEM	性 能 PERFORMANCE	測試條件 TEST CONDITIONS								
1	Total resistance 全阻值	<input checked="" type="checkbox"/> 10K±20% <input type="checkbox"/> 50K±20% <input type="checkbox"/> 100K±20% <input type="checkbox"/> 120K±20%	Between terminal 1 and terminal 3. 1-3 端子間.								
2	Resistance taper 阻抗特性型式	Type B; Refer to attached drawing “Resistance taper characteristics” B 型；見附頁 “阻型特性圖”	Percentage of the voltage of terminal 1-2 to the voltage of terminal 1-3. 端子 1-2 電壓對端子 1-3 電壓的百分比。								
3	Rated voltage 額定電壓	Linear Taper B : AC 50V DC 5V B 型: AC 50V DC 5V	$E = \sqrt{PR}$ E:額定電壓 Rated voltage(V) P:額定功率 Rated power(W) R:公稱全阻值 Nominal total resistance(Ω) The rated voltage is calculated by above formula. When the rated voltage exceeds the maximum operating voltage, the maximum operating voltage should be the rated voltage. 額定電壓按以上公式計算，當額定電壓超 過最大工作電壓時，最大工作電壓即為額 定電壓.								
4	Rated power 額定功率	Linear Taper B: 0.0125W B 型: 0.0125W	The rated power should be changed according to the following chart when the ambient temperature changed. 它與環境溫度按以下曲線變化。 Derating curve of rated dissipation <table border="1"> <caption>Derating curve of rated dissipation data</caption> <thead> <tr> <th>Ambient temperature (°C)</th> <th>Ratio to rated dissipation (%)</th> </tr> </thead> <tbody> <tr><td>0</td><td>100</td></tr> <tr><td>50</td><td>100</td></tr> <tr><td>70</td><td>33</td></tr> </tbody> </table>	Ambient temperature (°C)	Ratio to rated dissipation (%)	0	100	50	100	70	33
Ambient temperature (°C)	Ratio to rated dissipation (%)										
0	100										
50	100										
70	33										

5	Contact Noise 接觸雜音 (CRV)	<p>5% or less of the total resistance for over 60° (60° included) carbon film angle (Before the life test) ;</p> <p>10% or less of the total resistance for 40° thru 60° carbon film angle (Before the life test) ;</p> <p>15% or less of the total resistance for under 40° (40° included) carbon film angle (Before the life test) ;</p> <p>碳膜角度為 60° (含) 以上時, 全阻值的 5% 以下 (壽命測試前);</p> <p>碳膜角度為 40° ~60° 時, 全阻值的 10% 以下 (壽命測試前);</p> <p>碳膜角度為 40° (含) 以下時, 全阻值的 15% 以下 (壽命測試前).</p> <p>7% or less of the total resistance for over 60° (60° included) carbon film angle (After the life test) ;</p> <p>12% or less of the total resistance for 40° thru 60° carbon film angle (After the life test) ;</p> <p>18% or less of the total resistance for under 40° (40° included) carbon film angle (After the life test) ;</p> <p>碳膜角度為 60° (含) 以上時, 全阻值的 7% 以下 (壽命測試后);</p> <p>碳膜角度為 40° ~60° 時, 全阻值的 12% 以下 (壽命測試后);</p> <p>碳膜角度為 40° (含) 以下時, 全阻值的 18% 以下 (壽命測試后).</p>	<p>By the test angle of less than 90% carbon film angle .</p> <p>測試角度小於碳膜角度的 90% 。</p>
6	Voltage Divider Error 分壓誤差值	39.6%~60.4%	<p>Voltage divider error is defined the ratio of the voltage terminals 1-2 to terminals 1-3 after the drive arm rested. 5V D.C. shall be applied to the terminals between 1and 3 and then voltage divider error shall be measured with the drive arm operation on the line X-X and Y-Y. (Terminal 1-2/Terminal 1-3 × 100%)</p> <p>分壓誤差值是搖杆自由復歸后端子 1-2 與端子 1-3 電壓比例. 將 5V D.C 電壓加在端子 1-3 之間, 分壓誤差值在搖杆運作於 X-X 和 Y-Y 方向到底復歸后測試.(端子 1-2/端子 1-3 ×100%)</p>

7	Contact resistance 接觸阻抗 (ENR)	<p>10% or less of the total resistance for over 60° (60° included) carbon film angle (Before the life test);</p> <p>15% or less of the total resistance for 40° thru 60° carbon film angle (Before the life test);</p> <p>20% or less of the total resistance for under 40° (40° included) carbon film angle (Before the life test);</p> <p>碳膜角度為 60° (含) 以上時, 全阻值的 10% 以下 (壽命測試前);</p> <p>碳膜角度為 40° ~60° 時, 全阻值的 15% 以下 (壽命測試前);</p> <p>碳膜角度為 40° (含) 以下時, 全阻值的 20% 以下 (壽命測試前).</p> <p>15% or less of the total resistance for over 60° (60° included) carbon film angle (After the life test);</p> <p>20% or less of the total resistance for 40° thru 60° carbon film angle (After the life test);</p> <p>25% or less of the total resistance for under 40° (40° included) carbon film angle (After the life test);</p> <p>碳膜角度為 60° (含) 以上時, 全阻值的 15% 以下 (壽命測試后);</p> <p>碳膜角度為 40° ~60° 時, 全阻值的 20% 以下 (壽命測試后);</p> <p>碳膜角度為 40° (含) 以下時, 全阻值的 25% 以下 (壽命測試后).</p>	By the test angle of operation angle. 測試角度為全運轉角度。
8	Insulation resistance 絕緣阻抗值	More than 100 MΩ 100 MΩ 以上	Apply 250VDC to the individual terminals and case. 金屬外殼與端子間加 DC250V 電壓
9	Withstand voltage 耐電壓特性	Without arcing or breakdown 無損壞或弧光	Apply one minute of 250VAC to the individual terminals and case. 在特定端子與外殼間加 AC250V 電壓 1 分鐘.

二、MECHANICAL CHARACTERISTICS 機構特性

序號 NO.	項目 ITEM	性能 PERFORMANCE	測試條件 TEST METHODS AND REFERENCE
-----------	------------	-------------------	------------------------------------

1	Figure of lever operation 搖杆動作形式	Circular operating 圓形式	/
2	The stopper strength of the lever 搖杆止動強度	More than 3.1Kgf 3 seconds min 大於 3.1Kgf，至少 3 秒鐘	Apply side force on the lever perpendicular to the lever's axial direction.. 垂直於搖杆的力作用於搖杆上。
3	Pull strength of lever 搖杆拉拔強度	More than 5.0 Kgf 3 seconds min 大於 5.0Kgf，至少 3 秒鐘	Apply specified pull force on the lever upward. 作用於搖杆上，沿搖杆方向向上。
4	Push Strength of lever 搖杆推強度	More than 3.0 Kgf 3 seconds min 大於 3.0Kgf，至少 3 秒鐘	Apply specified push force on the lever downward. 作用於搖杆上，沿搖杆方向向下。
5	Operating force of lever 搖杆作用力	■160±40 gf □220±40 gf	Test position: More than 10 degrees deflection of lever. 搖杆偏斜 10 度以上之位置測定。
6	Accuracy of reset position of lever 搖杆復歸精度	±5°	Measure the angle between the lever and the axial center line after the lever pushed to the direction of X-X(Y-Y) and resets. 搖杆推向 X-X(Y-Y)方向自由復歸後測搖杆與垂直中心線的角度。
7	Operation angle of lever 搖杆使用有效角度	Refer to attached product drawing 見成品圖	The maximum angle of the lever pushed to the direction of X-X and Y-Y and 45°. 搖杆推向 X-X(Y-Y)和 45°方向的最大角度。

三. ENDURANCE CHARACTERISTICS 耐久性能 (Single test of item 單一測試項目)

序號 NO.	項目 ITEM	性能 PERFORMANCE	測試條件 TEST CONDITIONS
1	Free falling 自由落下試驗	No damage and lever deformation, but deformations of terminals and molded parts are allowed. 無不良產生,端子變形除外.	Height: 75cm Number of falls: 3 times 從高度為 75 釐米落下測試 3 次後

2	Dry heat 耐熱性	Variation of total resistance should be within $\begin{matrix} +5\% \\ -30\% \end{matrix}$. To be operated mechanically. 全阻值變化要在 $\begin{matrix} +5\% \\ -30\% \end{matrix}$ 以內， 機械方面能動作。	Temperature: $+80 \pm 2^{\circ}\text{C}$ Time: 96 hours The controller shall be subjected to standard atmospheric conditions for 2 hours after which measurement shall be made. 溫度在 $80 \pm 2^{\circ}\text{C}$ 放置 96 小時. 2 小時后正常狀態下測試.
3	Cold 耐寒性	The total resistance change should be within $\pm 20\%$. To be operated mechanically. 全阻值變化要在 $\pm 20\%$ 以內， 機械方面能動作。	Temperature: $-30 \pm 2^{\circ}\text{C}$ Time: 96 hours Surface moisture shall be removed, and then the controller shall be subjected to standard atmospheric conditions for 2 hours after which measurement shall be made. 溫度在 $-30 \pm 2^{\circ}\text{C}$ 放置 96 小時, 表面水份攝取后 2 小時正常狀態下測試.
4	Damp heat 耐濕性	Insulation resistance: more than $10\text{M } \Omega$ with 250V insulation resistance tester. The total resistance change should be within $\pm 20\%$. To be operated mechanically. 用 250V 絕緣測試機測試, 絕緣阻抗 $10\text{M}\Omega$ 以上, 全阻值變化要在 $\pm 20\%$ 以內， 機械方面能動作。	Temperature: $+60 \pm 2^{\circ}\text{C}$ Humidity: 90~95%RH Time: 96 hours Surface moisture shall be subjected to standard atmospheric conditions for 2 hours after which measurement shall be made. 溫度在 $60 \pm 2^{\circ}\text{C}$ 放置 96 小時, 表面水份攝取后 2 小時正常狀態下測試.
5	Temperature cycling test 溫度循環測試	The total resistance change should be within $\pm 20\%$. To be operated mechanically. 全阻值變化要在 $\pm 20\%$ 以內， 機械方面能動作。	Low temperature : $-10 \pm 3^{\circ}\text{C}$ 30 minutes High temperature: $+60 \pm 2^{\circ}\text{C}$ 30 minutes Number of cycles: 5 Surface moisture shall be removed, and then the controller shall be subjected to standard atmospheric conditions for 2 hours after which measurement shall be made. 在低溫為 $-10 \pm 3^{\circ}\text{C}$ 放置 30 分鐘, 高溫 $60 \pm 2^{\circ}\text{C}$ 放置 30 分鐘, 測試 5 次. 表面水份攝取后 2 小時后正常狀態下測試.
6	Resistance to soldering 焊錫性	Not less than 3/4 of the surface dipped shall be covered with new solder. 浸錫部分表面最少 3/4 被新錫覆蓋.	Temperature of solder: $235 \pm 5^{\circ}\text{C}$, Dipping duration: $3 \pm 0.5\text{S}$. 焊錫溫度: $235 \pm 5^{\circ}\text{C}$, 浸錫時間: 3 ± 0.5 秒.

7	Resistance to soldering heat 焊錫耐熱性	Variation of total resistance shall be within $\pm 5\%$, and terminals shall not work loose to injure electric contact, after test. 全阻值變化 $\pm 5\%$ 以內,測試後無端子鬆動,不會損壞電氣接點。	Soldering temperature $260\pm 5^{\circ}\text{C}$ for 5 sec. 焊錫溫度 $260\pm 5^{\circ}\text{C}$, 5 秒。
8	Number of cycles 耐久次數值	Total resistance \leq Initial value $\pm 20\%$. No mechanical malfunction. 全阻值變化 \leq 初始值 $\pm 20\%$. 機械方面能動作。	1,000,000 Cycles min

四、SWITCH CHARACTERISTICS (FOR WITH-SWITCH TYPE)

開關規格(適用於帶開關機種)

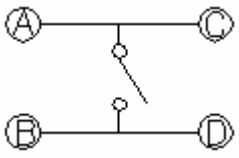
序號 NO.	項目 ITEM	性能 PERFORMANCE	測試條件 TEST CONDITIONS
1	Operating force 作動力	<input checked="" type="checkbox"/> $820 \pm 260 \text{ gf.cm}$ <input type="checkbox"/> $1000 \pm 260 \text{ gf.cm}$	Apply side force perpendicular to the lever's axial direction on the lever until the lever stops, measure the max force value. 將一個軸向力施加於搖杆上直到其不動為止,量取施力期間之最大值。
2	Travel 移動量	$0.5^{+0.5}_{-0.4} \text{ mm}$	Put the switch lever upward, apply 2 times of the static operating force over the lever's axial direction of the lever, measure the variance of the switch stroke. 將開關操作部(搖杆)置於靜止位置,並在操作柄中央施加兩倍於作動力之靜負荷測量柄被壓到不動時之移動距離。
3	Push strength 按壓強度	No mechanical and electrical malfunction. 不得有電氣及機構上之異常現象。	Put the switch lever upward; apply 3kgf of the static load over the vertical direction of the lever for 60 seconds. 將開關之操作部(搖杆)置於垂直方向,並沿操作方向加 3kgf 之靜負荷 60 秒。
4	Circuit diagram 電路圖		/

5	Contact resistance 接觸阻抗	Less than 100 mΩ 低於 100 mΩ	Apply 2 times of the operating force of the static load on the vertical direction of the lever, measure the resistance by using the Contact Resistance Tester with 1KHZ, 20mV, 5~50mA of current. 將兩倍於作動力之靜負荷加於操作柄之中央以(1KHZ,20mV, 5~50mA)微電流接觸阻抗計測定.
6	Insulation resistance 絕緣阻抗	More than 100 MΩ 100 MΩ以上	A voltage of DC100V is applied between terminals. 以 DC100V 之電壓加於端子間測定.
7	Withstand voltage 耐電壓	There shall be no damage, arc or dielectric breakdown. 無絕緣破壞之現象	A voltage of AC 250V(50~60HZ) shall be applied for 1 min between terminals. 以 AC250V(50~60HZ)電壓施加於端子間 1 分鐘.
8	Rated power 額定功率	12 V DC 50 mA	Within 70°C 小於 70°C
9	Number of cycles 開關耐久次數	Contact resistance 200mΩ MAX, No mechanical malfunction. 接觸阻抗最大 200mΩ, 機械方面能動作.	<input checked="" type="checkbox"/> 100,000 Cycles min <input type="checkbox"/> Other _____ Cycles min

五、General 一般事項

序號 NO.	項 目 ITEM	
1	Unless otherwise specified, test and measurement should be carried out in following condition: 如無特殊要求,試驗與測試將按以下條件進行：	
	Ambient temperature 溫度	15 °C to 35 °C
	Relative humidity 相對濕度	25% to 75%
	Air pressure 氣壓	86 KPa to 106 KPa
2	Operating temperature range 使用溫度範圍	-10 °C to +70 °C
3	Storage temperature range 儲存溫度範圍	-30 °C to +80 °C
Approved 核 准		Q.I.Department 審 查
		
		Design dept. 經 辦 者
		倪 艷 麗

Electrical Characteristics

Resistance Taper Characteristics

Resistance Taper Characteristic	Test point Rotation (%)	$\frac{V1-2}{V1-3} \times 100$ (%)	$\frac{V2-3}{V1-3} \times 100$ (%)
A	50	10-25	-
B	50	40-60	-
C	50 (Startled from 31)	-	10-25
D	50	6-15	-
E	50	-	18-34
W	30 (±5-degree)	5-15	-
	50	40-60	-
	70 (±5-degree)	85-95	-

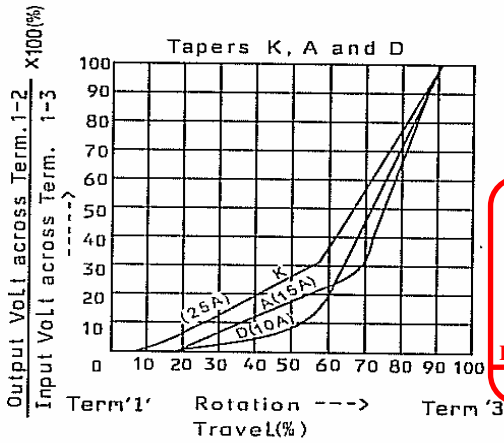
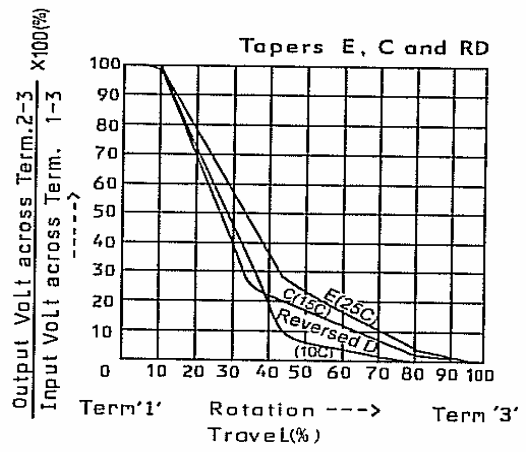

DOCUMENT CONTROLLED
29 MAY 2008
普耀集團有限公司
POLYSHINE HOLDINGS LTD
ENG. DEPT

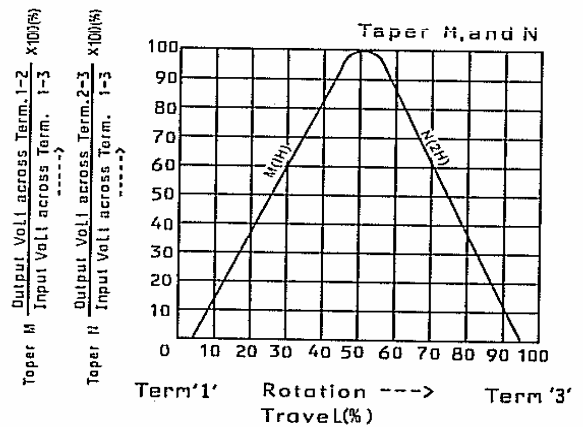
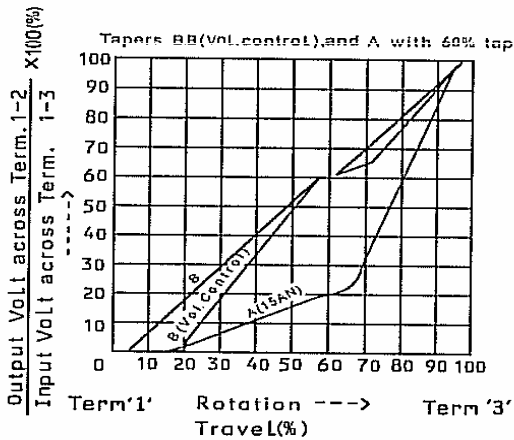
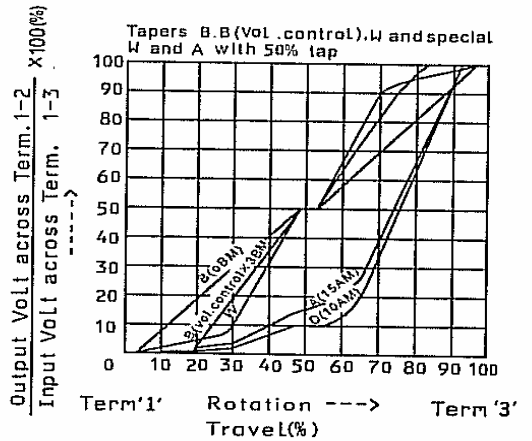
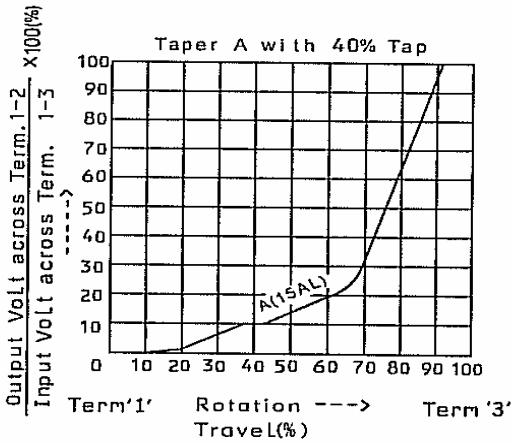
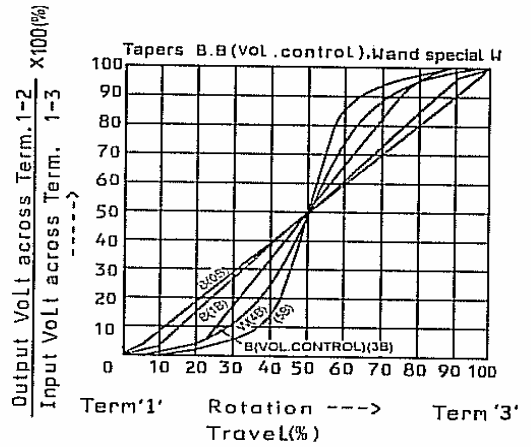

NOTE: Resistance characteristic of curve N is plotted with respect to terminal '3'