

Features

- Complete RF Transmitter
- SAW Resonator
- Transmit Range Up To 50m
- CMOS / TTL Input
- No Adjustable Components
- Stable Operating Frequency
- Wide Operating Voltage (3-12v)
- ASK Modulation
- Available as 315 or 433 MHz

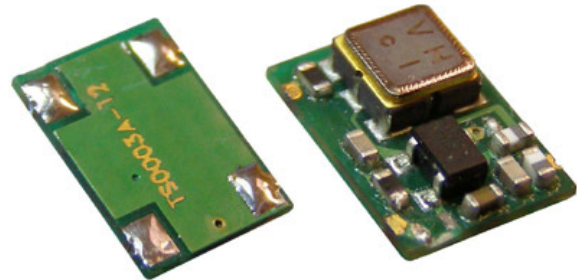

Applications

- Wireless Security Systems
- Garage Door controller
- Remote Gate Controls
- Remote Sensing
- Data Capture
- Sensor Reporting

Description

The Quasar UK AM hybrid transmitter module provides a complete RF transmitter which can be used to transmit data at up to 3KHz from any standard CMOS/TTL source.

The module is very simple to operate and offers a wide operating voltage range, the RF Power output increases in line with the voltage level applied to the module. Data can be supplied directly from a microprocessor or encoding device, thus keeping the component count down and ensuring a low hardware cost.

The modules are compatible with the Quasar UK Ltd. range of AM receivers to provide a complete solution.

Typical Application

For further information on this circuit please refer to the RF Solutions datasheet DS600.

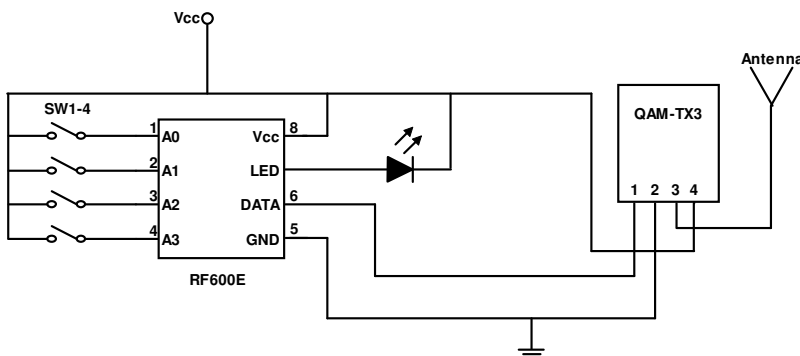

Part Numbers

Part Number	Description
QAM-TX3-433	AM Transmitter Module, 433MHz

Module mounting considerations

Good RF layout practice should be observed, in particular:

1. All grounds must be low impedance, keep all ground returns as short as possible, do not use shared vias
2. Any ground return required by the module's antenna or feed should be connected directly to the RF GND pins at the antenna end of the module
3. All connecting tracks should be kept as short as possible to avoid any problems with stray RF pickup
4. Where the connection between the module and it's antenna does not form part of the antenna itself, it should be made using 50Ω microstrip line or coax or a combination of both
5. Fill all unused PCB area around the module with ground plane
6. Use of an uninterrupted ground plane (dual layer PCB) can be highly effective in cutting radiated interference and its use is strongly recommended
7. It is essential that a stable power supply is used. The RF Power output of this module changes in line with the supply voltage level, do not exceed the voltage level stated for the module's output power level specification
8. Ensure that the modules power supply pins are adequately decoupled using a low pass filter (LC), choose an inductor with a low dc series resistance (<0.1Ω) and place the filter as close to the module's power supply pins as possible
9. The choice of antenna is important, it must not have gain in any direction as this will increase the radiated emissions beyond approval levels
10. Use a reactive pi (low pass) matching network between the module's RF output and the antenna, this will maximise the RF power transfer and improve harmonics filtering

Technical Specifications

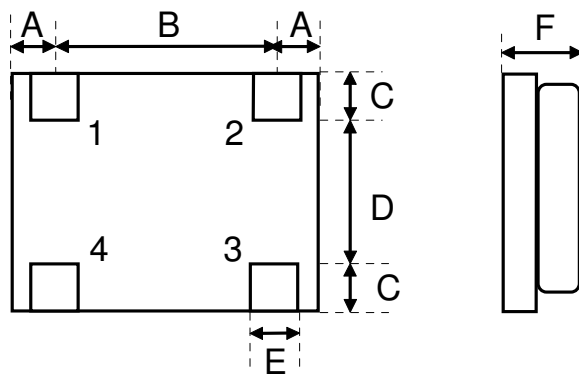

Please Note

1. Components on reverse
2. Dimensions in mm
3. Tolerance of +/- 0.15

Dimensions

Pin	Measurements (mm)
A	1
B	5.08
C	1.0
D	3.2
E	1.2
F	1.8

Pin Descriptions

Pin	Name	Description
1	IN	Data input
2	GND	Ground
3	ANT	External Antenna
4	Vcc	Supply Voltage

Electrical Characteristics

Ambient temp = 25°C unless otherwise stated.

Characteristic	Min.	Typ.	Max.	Dimensions
Supply Voltage	3		12	Vdc
Supply Current (Vcc=12V)			12.5	mA
Output Power (Vcc=3V IN=1kHz)		10		dBm
Working Frequency		433.92		MHz
Frequency Accuracy		+/- 75		KHz
Data Rate		1	3,000	Hz
Operating Temperature	-20		+85	°C

Tape and Reel Dimensions

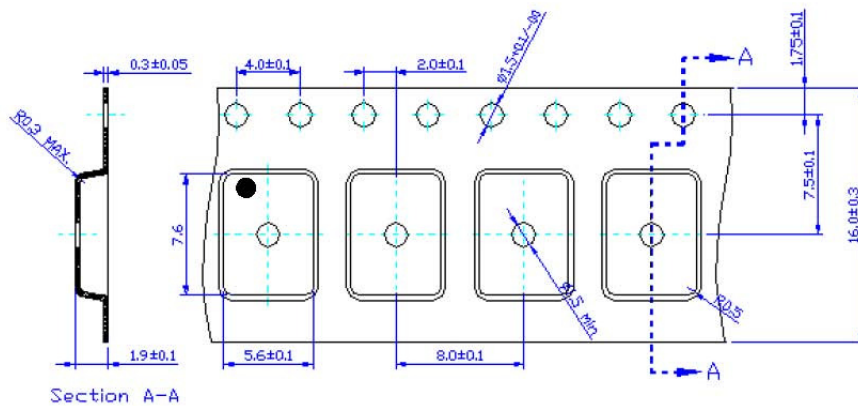

Maximum Soldering Profile

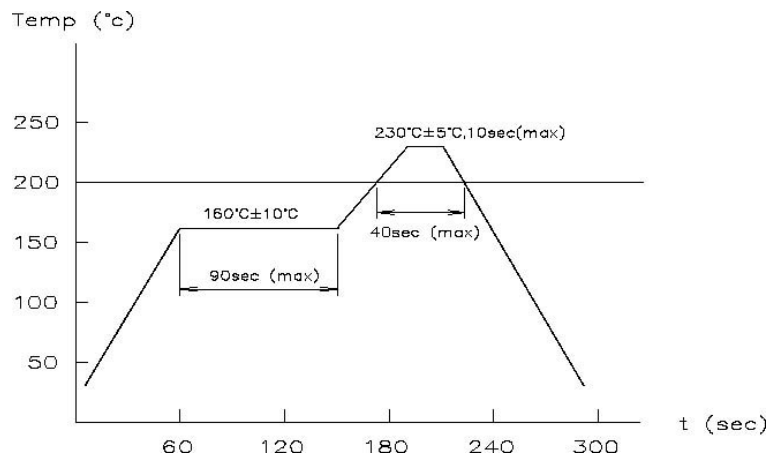

www.quasaruk.co.uk

Information contained in this document is believed to be accurate, however no representation or warranty is given and no liability is assumed by Quasar (UK) Ltd. with respect to the accuracy of such information. Use of products as critical components in life support systems is not authorised except with express written approval from Quasar (UK) Ltd.