

**2009-2010
MURATA PRODUCTS**

muRata







Innovator in Electronics



△Note • This PDF catalog is downloaded from the website of Murata Manufacturing co., ltd. Therefore, it's specifications are subject to change or our products in it may be discontinued without advance notice. Please check with our sales representatives or product engineers before ordering.
• This PDF catalog has only typical specifications because there is no space for detailed specifications. Therefore, please approve our product specifications or transact the approval sheet for product specifications before ordering.

CONTENTS

Minimum Quantity Guide 2-14

1		<h2>Capacitors</h2> <p>Global Part Numbering 16-25</p> <p>Monolithic Ceramic Capacitors Capacitance Range 26</p> <p>Monolithic Ceramic Capacitors 27-81</p> <p>Monolithic Ceramic Capacitors for Medium Voltage 82-88</p> <p>Monolithic Ceramic Capacitors Safety Standard Certified 89-92</p> <p>Monolithic Ceramic Cap. (Lead Type) · 93-103</p> <p>Disc Ceramic Capacitors Capacitance Range · 104</p> <p>High Voltage Ceramic Cap. (250V-6.3kV) · 104-110</p> <p>Safety Standard Certified Ceramic Cap. · 110-115</p> <p>High Voltage Ceramic Cap. (10-40kV) · 116-118</p> <p>Ceramic Trimmer Capacitors 119-122</p>
2		<h2>Noise Suppression Products/ EMI Suppression Filters</h2> <p>Global Part Numbering 124-128</p> <p>EMIFIL® (SMD) 129-159</p> <p>Common Mode Choke Coil 160-167</p> <p>EMIFIL® (Lead Type) 168-177</p> <p>Block Type EMIFIL® (LC Combined) · 177-178</p> <p>Leaded Common Mode Choke Coil 179</p> <p>EMIGUARD® (EMIFIL® with Varistor Function) 179-180</p> <p>AC Line Filters 181-187</p> <p>Microwave Absorber 188</p> <p>Ferrite Core for EMI Suppression 189-195</p>
3		<h2>Inductors (Coils)</h2> <p>Global Part Numbering 198-199</p> <p>Chip Coils Inductance Range 200</p> <p>Chip Inductor (Chip Coil) 201-240</p> <p>Balun 241</p> <p>Coupler 242</p>
4		<h2>Resistors</h2> <p>Global Part Numbering 244</p> <p>High Voltage Resistors 245</p> <p>R Networks 245-246</p> <p>Trimmer Potentiometers 246-254</p>
5		<h2>Resonators</h2> <p>Global Part Numbering 256</p> <p>Crystal Resonators 257</p> <p>Ceramic Resonators (CERALOCK®)(MHz) · 257-262</p> <p>Ceramic Resonators (CERALOCK®)(kHz) · 262-263</p>
6		<h2>Filters for Audio Visual Equipment</h2> <p>Global Part Numbering 266-267</p> <p>CERAFIL® for AM 268-270</p> <p>CERAFIL® for FM 270-276</p> <p>Discriminators for FM 277</p> <p>CERAFIL® for TV/VCR 278</p> <p>Traps for TV/VCR 279</p> <p>SAW Traps 280</p>
7		<h2>Filters for Communication Equipment</h2> <p>Global Part Numbering 284-285</p> <p>Duplexers 286-288</p> <p>for RF/Local 288-298</p> <p>for IF 299-315</p>

Note • This PDF catalog is downloaded from the website of Murata Manufacturing co., Ltd. Therefore, it's specifications are subject to change or our products in it may be discontinued without advance notice. Please check with our sales representatives or product engineers before ordering.
• This PDF catalog has only typical specifications because there is no space for detailed specifications. Therefore, please approve our product specifications or transact the approval sheet for product specifications before ordering.

Details of these products are available at "Search Engine" on the web. (Except for customized products)
(<http://search.murata.co.jp/search/>)

8		<h2>Microwave Components</h2>		1
		<p>Global Part Numbering 318-320 Isolators..... 321-322 Chip Multilayer Hybrid Couplers..... 323-325 Hybrid Dividers 325 Chip Multilayer Diplexers 326 Chip Multilayer Hybrid Baluns 326-327 Chip Antennas 328-329</p>	<p>High Frequency Monolithic Ceramic Capacitors · 330-341 High Frequency Single Layer Microchip Capacitors · 342-344 Thin Film Circuit Substrate (RUSUB®) 345 Coaxial Connectors 346 Coaxial Connectors with Switches · 346-347</p>	2

9		<h2>Sensors</h2>		3
		<p>Global Part Numbering 350-352 Sensor Applications..... 353 PTC Thermistors (for Overheat Sensing)· 354-356 Pyroelectric Infrared Sensors 356 Fresnel Lens 356-357 Ultrasonic Sensors 357-359 Shock Sensors 360</p>	<p>Gyro Sensors 360-361 Rotary Position Sensors 361 Rotary Sensors 361 Magnetic Pattern Recognition Sensors · 362 Magnetic Switch..... 362-363</p>	4

10		<h2>Thermistors</h2>		5
		<p>Global Part Numbering 366-367 PTC Thermistors for Heater 368 PTC for Circuit Protection 368-373 PTC for Overheat Sensing 374-376 PTC for Motor Starters 376-377 NTC for Temp. Sensor and Compensation · 377-381</p>	<p>NTC for Inrush Current Suppression · 381-382</p>	6

11		<h2>Power Supplies</h2>		7
		<p>Switching Power Supplies 384 Ultra Low Profile Switching Power Supplies 385 DC-DC Converters 385-388 Ionizer Modules (Ionissimo™)..... 389</p>		8

12		<h2>Sound Components</h2>		9
		<p>Global Part Numbering 392 Piezoelectric Sounders 393-395 Piezoelectric Ringers (PIEZORINGER®) · 396 Piezoelectric Buzzers 397 Piezoelectric Diaphragms 398</p>		10

<p>New Product Guide 399 Alphabetic Product Name Index 400</p>	<p>Part Numbers Alphabetic Index 401-404 Murata's website 405</p>	11
---	--	----

for EU RoHS Compliant

- All the products in this catalog comply with EU RoHS.
- EU RoHS is "the European Directive 2002/95/EC on the Restriction of the Use of Certain Hazardous Substances in Electrical and Electronic Equipment".
- For more details, please refer to our website 'Murata's Approach for EU RoHS' (<http://www.murata.com/info/rohs.html>).

△Note • This PDF catalog is downloaded from the website of Murata Manufacturing co., Ltd. Therefore, it's specifications are subject to change or our products in it may be discontinued without advance notice. Please check with our sales representatives or product engineers before ordering.
 • This PDF catalog has only typical specifications because there is no space for detailed specifications. Therefore, please approve our product specifications or transact the approval sheet for product specifications before ordering.

1 Capacitors

 Packaging Code: **D, E, F, J** Paper Tape **L, K** Embossed Tape **T** Tray

Product Names	Part Number	Dimensions (mm)			Minimum Quantity (pcs.) (Packaging Code)					
		L	W	T	Ø180mm Reel	Ø330mm Reel	Bulk (Bag)	Bulk Case	Ammo Pack	
● Chip Monolithic Ceramic Capacitors for General Purpose	GRM02	0.4	0.2	0.2	20000 ¹⁾ (D) /40000 ¹⁾ (L)		1000 (B)			
	GRM03	0.6	0.3	0.3	15000 (D)	50000 (J)	1000 (B)			
	GRM15	1.0	0.5	0.25/0.3	10000 (D)	50000 (J)	1000 (B)			
				0.5	10000 (D)	50000 (J)	1000 (B)	50000 (C)		
	GRM18	1.6	0.8	0.5	4000 (D)	10000 (J)	1000 (B)			
				0.8	4000 (D)	10000 (J)	1000 (B)	15000 ²⁾ (C)		
	GRM21	2.0	1.25	0.6	4000 (D)	10000 (J)	1000 (B)	10000 (C)		
				0.85	4000 (D)	10000 (J)	1000 (B)			
				1.25/1.0	3000 (L)	10000 (K)	1000 (B)	5000 ²⁾ (C)		
	GRM31	3.2	1.6	0.6/0.85	4000 (D)	10000 (J)	1000 (B)			
				1.15	3000 (L)	10000 (K)	1000 (B)			
				1.6	2000 (L)	6000 (K)	1000 (B)			
	GRM32	3.2	2.5	0.85	4000 (L)	10000 (K)	1000 (B)			
				1.15	3000 (L)	10000 (K)	1000 (B)			
				1.35	2000 (L)	8000 (K)	1000 (B)			
				1.6	2000 (L)	6000 (K)	1000 (B)			
				1.8/2.0 /2.5	1000 (L)	4000 (K)	1000 (B)			
	for Automotive	GCM03	0.6	0.3	0.3	15000 (D)	50000 (J)	1000 (B)		
		GCM15	1.0	0.5	0.5	10000 (D)	50000 (J)	1000 (B)	50000 (C)	
GCM18		1.6	0.8	0.8	4000 (D)	10000 (J)	1000 (B)	15000 ²⁾ (C)		
GCM21		2.0	1.25	0.6	4000 (D)	10000 (J)	1000 (B)	10000 (C)		
				0.85	4000 (D)	10000 (J)	1000 (B)			
				1.25	3000 (L)	10000 (K)	1000 (B)	5000 ²⁾ (C)		
GCM31		3.2	1.6	0.85	4000 (D)	10000 (J)	1000 (B)			
				1.15	3000 (L)	10000 (K)	1000 (B)			
				1.6	2000 (L)	6000 (K)	1000 (B)			
GCM32		3.2	2.5	1.15	3000 (L)	10000 (K)	1000 (B)			
				1.35	2000 (L)	8000 (K)	1000 (B)			
				1.8/1.6	1000 (L)	4000 (K)	1000 (B)			
High-Q Type	GJM03	0.6	0.3	0.3	15000 (D)	50000 (J)	1000 (B)			
	GJM15	1.0	0.5	0.5	10000 (D)	50000 (J)	1000 (B)	50000 (C)		
Monolithic Microchip	GMA0D	0.38	0.38	0.3			400 (T)			
	GMA05	0.5	0.5	0.35			400 (T)			
	GMA08	0.8	0.8	0.5			400 (T)			
for Bonding	GMD03	0.6	0.3	0.3	15000 (D)	50000 (J)	1000 (B)			
	GMD15	1.0	0.5	0.5	10000 (D)	50000 (J)	1000 (B)			
Capacitor Array	GNM0M	0.9	0.6	0.45	10000 (D)	50000 (J)	1000 (B)			
	GNM1M	1.37	1.0	0.5 /0.6/0.8	4000 (D)	10000 (J)	1000 (B)			
	GNM21	2.0	1.25	0.5/0.6 /0.85	4000 (D)	10000 (J)	1000 (B)			
	GNM31	3.2	1.6	0.8/0.85	4000 (D)	10000 (J)	1000 (B)			
1.0/1.15				3000 (L)	10000 (K)	1000 (B)				

1) 8mm width 2mm pitch paper Taping. 4mm width 1mm pitch Embossed Taping.

2) There are parts number without bulk case.

Continued on the following page.

● All dimensions given are nominal without mention.

"Minimum Quantity" means the number of units of each delivery or order. The quantity should be an integral multiple of the "Minimum Quantity". (As for products series with ★mark, bulk (bag) quantities shown here differ from actual delivery quantities in a package.) Please contact nearest sales office for details and for any other products not listed above.

Continued from the preceding page.

Product Names	Part Number	Dimensions (mm)			Minimum Quantity (pcs.) (Packaging Code)				
		L	W	T	Ø180mm Reel	Ø330mm Reel	Bulk (Bag)	Bulk Case	Ammo Pack
Low ESL Wide Width Type	LLL15	0.5	1.0	0.3	10000 (E)	50000 (F)	1000 (B)		
	LLL18	0.8	1.6	0.6	4000 (L)	10000 (K)	1000 (B)		
	LLL21	1.25	2.0	0.6	4000 (L)	10000 (K)	1000 (B)		
				0.85	3000 (L)	10000 (K)	1000 (B)		
	LLL31	1.6	3.2	0.7	4000 (L)	10000 (K)	1000 (B)		
				1.15	3000 (L)	10000 (K)	1000 (B)		
	LLA18	1.6	0.8	0.5	4000 (L)	10000 (K)	1000 (B)		
	LLA21	2.0	1.25	0.5	4000 (L)	10000 (K)	1000 (B)		
				0.85	3000 (L)	10000 (K)	1000 (B)		
	LLA31	3.2	1.6	0.5	4000 (L)	10000 (K)	1000 (B)		
				0.85/1.15	3000 (L)	10000 (K)	1000 (B)		
	LLM21	2.0	1.25	0.5	4000 (L)	10000 (K)	1000 (B)		
LLM31	3.2	1.6	0.5	4000 (L)	10000 (K)	1000 (B)			
for Medium Voltage	GRM18	1.6	0.8	0.8	4000 (D)				
	GRM21	2.0	1.25	1.0	4000 (D)				
				1.25	3000 (L)				
	GRM31/GR731	3.2	1.6	1.0	4000 (D)				
				1.25	3000 (L)				
				1.6	2000 (L)				
	GRM32	3.2	2.5	1.0	4000 (D)				
				1.25	3000 (L)				
				1.5	2000 (L)				
				2.0	1000 (L)				
	GRM42/GR442	4.5	2.0	1.0	3000 (L)				
				1.5	2000 (L)				
2.0				2000 (L)					
GRM43/GR443	4.5	3.2	1.5	1000 (L)					
			2.0	1000 (L)					
GRM55/GR455	5.7	5.0	2.0	1000 (L)					
for Medium Voltage Automotive	GCM21	2.0	1.25	1.0	4000 (D)				
	GCM31	3.2	1.6	1.0	4000 (D)				
				1.25	3000 (L)				
GCM32	3.2	2.5	1.0	4000 (D)					
Products which are Based on the Electrical Appliance and Material Safety Law of Japan	GA242	4.5	2.0	1.5	2000 (L)				
	GA243	4.5	3.2	1.5	1000 (L)				
				2.0	1000 (L)				
GA255	5.7	5.0	2.0	1000 (L)					
Safety Standard Certified	GA342	4.5	2.0	1.0	3000 (L)				
				1.5	2000 (L)				
				2.0	2000 (L)				
	GA343	4.5	3.2	1.5	1000 (L)				
				2.0	1000 (L)				
	GA352	5.7	2.8	1.5	1000 (L)				
	GA355	5.7	5.0	1.5	1000 (L)				
				2.0	1000 (L)				
2.5				500 (L)					
2.7				500 (L)					
			2.9	500 (L)					

Continued on the following page.

● All dimensions given are nominal without mention.

Note • This PDF catalog is downloaded from the website of Murata Manufacturing co., ltd. Therefore, it's specifications are subject to change or our products in it may be discontinued without advance notice. Please check with our sales representatives or product engineers before ordering.
• This PDF catalog has only typical specifications because there is no space for detailed specifications. Therefore, please approve our product specifications or transact the approval sheet for product specifications before ordering.

Continued from the preceding page.

Product Names	Part Number	Dimensions (mm)			Minimum Quantity (pcs.) (Packaging Code)				
		L	W	T	Ø180mm Reel	Ø330mm Reel	Bulk (Bag)	Bulk Case	Ammo Pack
● Monolithic Ceramic Capacitors Lead Type Radial Lead Type	RPE_2 ¹⁾ /RDE_2 ¹⁾	5.0	3.5	2.5			500 (B)		2000 (A)
				3.15			500 (B)		2000 (A)
	RPE_3 ¹⁾ /RDE_3 ¹⁾	5.0	4.0	3.15			500 (B)		2000 (A)
				2.5			500 (B)		2000 (A)
		5.5	5.0	4.0			500 (B)		1500 (A)
	RPE_4 ¹⁾	7.5	5.0	2.5			500 (B)		2000 (A)
				3.15			500 (B)		2000 (A)
	RPE_5 ¹⁾ /RDE_5 ¹⁾	7.5	7.5 ⁴⁾	4.0			500 (B)		2000 ²⁾ (A)
	RPE_6 ¹⁾	10.0	10.0	4.0			500 (B)		1500 (A)
	RPE_7 ¹⁾	12.5	12.5	5.0			100 (B)		
	RPE_8 ¹⁾ /RDE_8 ¹⁾	7.5	5.5	4.0			500 (B)		1500 (A)
	RHE_1 ¹⁾	4.0	3.5	2.5			500 (B)		2000 (A)
				3.15			500 (B)		2000 (A)
RHD_2 ¹⁾	5.7	4.5	4.5			500 (B)		1500 (A)	
RDE_U ¹⁾	7.7	12.5 ⁴⁾	4.0			200 (B)		1000 (A)	
● High Voltage Ceramic Capacitors 125 deg. / Low - Loss / DC250V - 3.15kV	DES (other than below) *						1000 (B)		
	DES_N2A								1500 (A)
	DES_N3A								1000 (A)
	DES_N7A								500 (A)
	DEH (other than below) *						1000 (B)		
	DEH_N2A								1500 (A)
	DEH_N3A/DEH_P3A								900 ³⁾ (A)
	DEH_N7A								500 (A)
125 deg. / Class 1 / DC1kV - 3.15kV	DEA (other than below) *						1000 (B)		
	DEA_N2A/DEA_P2A								1500 (A)
	DEA_N3A/DEA_P3A								900 ³⁾ (A)
	DEA_N7A								500 (A)
Class 2 / DC1kV - 3.15kV	DEB (other than below) *						1000 (B)		
	DEB_N2A/DEB_P2A								1500 (A)
	DEB_N3A/DEB_P3A								900 ³⁾ (A)
	DEB_N7A								500 (A)
Class 1, 2 / DC6.3kV Only for LCD Backlight Inverter Circuit/6.3kVp-p	DEC*						1000 (B)		
	DEF (other than below) *						1000 (B)		
	DEF_N3A								900 (A)
● Safety Standard Certified Ceramic Capacitors Type KY (UL, CSA, IEC60384-14 Class X1 / Y2)	DE2 (other than below) *						1000 (B)		
	DE2_N2A								1000 (A)
	DE2_N3A								900 (A)
Type KH (UL, CSA, IEC60384-14 Class X1 / Y2)	DE2 (other than below) *						1000 (B)		
	DE2_N3A								900 (A)
	DE2_N7A								400 (A)
Type KX (UL, CSA, IEC60384-14 Class X1 / Y1)	DE1 (other than below) *						1000 (B)		
	DE1_N4A								500 (A)
	DE1_N5A								500 (A)
Products which are Based on the Electrical Appliance and Material Safety Law of Japan	DEJ (other than below) *						1000 (B)		
	DEJ_N2A								1500 (A)
	DEJ_N3A/DEJ_P3A								1000 (A)

- 1) The last figure is at twelfth digit of whole part number which prescribes the size of capacitors.
- 2) Depending on capacitance, some products are supplied on 1500pcs.
- 3) 1000pcs. for 1kV.
- 4) DC630V: W+0.5mm.

Continued on the following page.

● All dimensions given are nominal without mention.

4

Note • This PDF catalog is downloaded from the website of Murata Manufacturing co., Ltd. Therefore, it's specifications are subject to change or our products in it may be discontinued without advance notice. Please check with our sales representatives or product engineers before ordering.
 • This PDF catalog has only typical specifications because there is no space for detailed specifications. Therefore, please approve our product specifications or transact the approval sheet for product specifications before ordering.

Continued from the preceding page.

Product Names	Part Number	Dimensions (mm)			Minimum Quantity (pcs.) (Packaging Code)				
		L	W	T	Ø180mm Reel	Ø330mm Reel	Bulk (Bag)	Bulk Case	Ammo Pack
● Ceramic Trimmer Capacitors SMD Type	TZB4	4.5	4.0	3.0	500 (R00)	2500 (R01)	500 (B00)		
	TZC3	4.5	3.2	1.6	1000 (R00)		500 (B00)		
	TZR1	1.7	1.5	0.85	3000 (R00)		500 (B00)		
	TZS2	2.7	2.2	0.95	3000 (R00)		500 (B00)		
	TZV2	3.2	2.3	1.45	2000 (R00)		500 (B00)		
	TZY2	3.2	2.5	1.25	2000 (R00)		500 (B00)		
	SMD Type High-Q & High Power Type	TZW4	5.2	4.2	2.6	500 (R00)		100 (B00)	
Lead Type	TZ03						1000 (B00)		

2 Noise Suppression Products/EMI Suppression Filters

Packaging Code: D, J Paper Tape L, K Embossed Tape

Product Names	Part Number	Dimensions (mm)			Minimum Quantity (pcs.) (Packaging Code)					
		L	W	T	Ø180mm Reel	Ø330mm Reel	Bulk (Bag)	Ammo Pack	Sheet	
● EMIFIL® (Inductor Type) Chip Ferrite Bead	BLM02	0.4	0.2	0.2	20000 (D)		1000 (B)			
	BLM03	0.6	0.3	0.3	15000 (D)	50000 (J)	1000 (B)			
	BLM15	1.0	0.5	0.5	10000 (D)	50000 (J)	1000 (B)			
	BLM18 (BLM18KG_TN)	1.6	0.8	0.8	4000 (D)	10000 (J)	1000 (B)			
	(BLM18S)			(0.6)	(4000 (D))	(10000 (J))	(1000 (B))			
	(BLM18T)			(0.5)	(10000 (D))	(30000 (J))	(1000 (B))			
	BLM21 (BLM21BD222SN1/BD272SN1)	2.0	1.25	0.85	4000 (D)	10000 (J)	1000 (B)			
				(1.25)	(3000 (L))	(10000 (K))	(1000 (B))			
	BLM31	3.2	1.6	1.1	3000 (L)	10000 (K)	1000 (B)			
	BLM41	4.5	1.6	1.6	2500 (L)	8000 (K)	1000 (B)			
Chip Ferrite Bead for GHz Noise	BLM15H/BLM15E	1.0	0.5	0.5	10000 (D)	50000 (J)	1000 (B)			
	BLM18H/BLM18E	1.6	0.8	0.8/0.5	4000 (D)	10000 (J)	1000 (B)			
Chip Ferrite Bead for High-GHz Noise	BLM15G	1.0	0.5	0.5	10000 (D)	50000 (J)	1000 (B)			
	BLM18G	1.6	0.8	0.8	4000 (D)	10000 (J)	1000 (B)			
Chip Ferrite Bead (Array)	BLA2A	2.0	1.0	0.5	10000 (D)	50000 (J)	1000 (B)			
	BLA31	3.2	1.6	0.8	4000 (D)	10000 (J)	1000 (B)			
● EMIFIL® (Capacitor Type) Single Circuit Type for Signal Lines	NFM18C	1.6	0.8	0.6	4000 (D)		500 (B)			
	NFM21C	2.0	1.25	0.85	4000 (D)		500 (B)			
	NFM3DC	3.2	1.25	0.7	4000 (L)		500 (B)			
	NFM41C	4.5	1.6	1.0	4000 (L)		500 (B)			
	Single Circuit Type for Large Current	NFM18PC (NFM18PS)	1.6	0.8	0.6/0.8 (0.6)	4000 (D)		500 (B)		
		NFM21P	2.0	1.25	0.85	4000 (D)		500 (B)		
		NFM3DP	3.2	1.25	0.7	4000 (L)		500 (B)		
		NFM31P	3.2	1.6	1.3	3000 (L)		500 (B)		
		NFM41P	4.5	1.6	1.0	4000 (L)		500 (B)		
		NFM55P	5.7	5.0	2.2	500 (L)		100 (B)		
Array	NFA31C	3.2	1.6	0.8	4000 (D)		100 (B)			
● EMIFIL® (LC Combined) Feed Through Type	NFE31P	3.2	1.6	1.6	2000 (L)	8000 (K)	500 (B)			
	NFE61P	6.8	1.6	1.6	2500 (L)	8000 (K)	500 (B)			
Wire Wound Type	NFW31S	3.2	1.6	1.8	2000 (L)	7500 (K)				
Multilayer Type	NFL18ST	1.6	0.8	0.8	4000 (D)		1000 (B)			
	NFL18SP	1.6	0.8	0.6	4000 (D)		1000 (B)			
	NFL21S	2.0	1.25	0.85	4000 (D)		1000 (B)			

Continued on the following page.

● All dimensions given are nominal without mention.

Note • This PDF catalog is downloaded from the website of Murata Manufacturing co., Ltd. Therefore, it's specifications are subject to change or our products in it may be discontinued without advance notice. Please check with our sales representatives or product engineers before ordering.
• This PDF catalog has only typical specifications because there is no space for detailed specifications. Therefore, please approve our product specifications or transact the approval sheet for product specifications before ordering.

Continued from the preceding page.

Product Names	Part Number	Dimensions (mm)			Minimum Quantity (pcs.) (Packaging Code)					
		L	W	T	Ø180mm Reel	Ø330mm Reel	Bulk (Bag)	Ammo Pack	Sheet	
● EMIFIL® (LC Combined) Array	NFA18S	1.6	0.8	0.5/0.6	4000 (L)		1000 (B)			
	NFA21S	2.0	1.25	0.5/0.85	4000 (L)		1000 (B)			
● EMIFIL® (RC Combined) Single Circuit Type	NFR21G	2.0	1.25	0.5	4000 (L)		500 (B)			
	Array NFA31G	3.2	1.6	0.8	4000 (D)		100 (B)			
● Common Mode Choke Coil	Film Type DLP0NS	0.85	0.65	0.45	5000 (L)		500 (B)			
	DLP11S	1.25	1.0	0.82	3000 (L)		500 (B)			
	DLP31S	3.2	1.6	1.15	3000 (L)		500 (B)			
	Film Type (Array) DLP2AD	2.0	1.0	0.82	3000 (L)		500 (B)			
	DLP31D	3.2	1.6	1.15	3000 (L)		500 (B)			
	Multilayer Type DLM11G	1.25	1.0	0.5	10000 (D)		1000 (B)			
	DLM2HG	2.5	2.0	1.2	3000 (L)		1000 (B)			
	Wire Wound Type	DLW21S	2.0	1.2	1.2	2000 (L)		500 (B)		
		DLW21H	2.0	1.2	0.9	3000 (L)		500 (B)		
		DLW31S	3.2	1.6	1.9	2000 (L)		500 (B)		
	Wire Wound Type for Large Current	DLW5AH	5.0	3.6	4.3	400 (L)	1500 (K)	100 (B)		
		DLW5BS	5.0	5.0	4.5	400 (L)	1500 (K)	100 (B)		
		DLW5BT	5.0	5.0	2.5	700 (L)	2500 (K)	100 (B)		
● Leaded EMIFIL® (Capacitor Type)	Small Type DSN6/DSS6 ¹⁾						250/500	2000		
	Standard Type DSN9N ¹⁾						250/500	2000		
		DSS9N ¹⁾					800 ²⁾	200/500		
		DST9 ¹⁾						200/250	1000	
	Heavy Duty Type DSN9H ¹⁾							250/500	2000	
		DSS9H ¹⁾					800 ²⁾	200/500		
DST9H ¹⁾							200/250	1000		
● Leaded EMIFIL® (Inductor Type)	BL03						1000 (B)	2000 (A)		
	BL02						500 (B)	1500 (A)		
	BL01					2000 ³⁾ (J)	500 (B)	1000 (A)		
● Block Type EMIFIL® (LC Combined)	BNX02 □	9.1	12.1	3.1	400 (L)	1500 (K)	100 (B)			
	BNX00 □						100 ⁴⁾			
	BNX01 □						150 ⁴⁾			
● Leaded Common Mode Choke Coil PLT09H							100 ⁴⁾ (B)			
● EMIGUARD® (EMIFIL® with Varistor Function) Lead Type EMIGUARD®	VFR3V/VFS6V						250 (T51B)	2000 (U31A)		
	VFS9V ¹⁾					800 ²⁾	200			
● AC Line Filters	Common Mode Choke Coil PLA10/PLH10						1260 ⁵⁾			
	Hybrid Choke Coil PLY10						1200 ⁵⁾			
		PLY17						1080 ⁶⁾		
● Ferrite Core	FSSA101005RNN_S								500	
	FSSA151005RNN_S								500	
	FSSA205007RNN_S								200	
	FSSA220007RNN_S								200	
	FSSA290005RNN_S								200	

- 1) Packaging Codes vary depending on lead length and lead type.
- 2) ø320mm reel.
- 3) BL01RN1A1F1J is also available for ø320mm reel (2,000pcs.).
- 4) Box
- 5) Box. 1800pcs. of magazine is also available.
- 6) Box. 1920pcs. of magazine is also available.

Continued on the following page.

● All dimensions given are nominal without mention.

6

Note • This PDF catalog is downloaded from the website of Murata Manufacturing co., Ltd. Therefore, it's specifications are subject to change or our products in it may be discontinued without advance notice. Please check with our sales representatives or product engineers before ordering.
 • This PDF catalog has only typical specifications because there is no space for detailed specifications. Therefore, please approve our product specifications or transact the approval sheet for product specifications before ordering.

3 Inductors (Coils)

Packaging Code: **D**, **J** Paper Tape **L**, **K** Embossed Tape

Product Names	Part Number	Dimensions (mm)			Minimum Quantity (pcs.) (Packaging Code)			
		L	W	T	ø180mm Reel	ø330mm Reel	Bulk (Bag)	
● Chip Inductor (Chip Coil)	for High Frequency Horizontal Wire Wound	LQW04A	0.8	0.4	0.4	10000 (D)		500 (B)
		LQW15A	1.0	0.5/0.6	0.5	10000 (D)		500 (B)
		LQW18A	1.6	0.8	0.8	4000 (D)	10000 (J)	500 (B)
	for High Frequency Vertical Wire Wound	LQW2BH	2.0	1.5	1.7	2000 (L)	7500 (K)	
		LQW31H	3.2	1.6	1.8	2000 (L)	7500 (K)	
	for High Frequency Horizontal Wire Wound Ferrite Type	LQW21H	2.0	1.2	0.9	3000 (L)		500 (B)
	for High Frequency Vertical Wire Wound Ferrite Type	LQH31H	3.2	1.6	1.8	2000 (L)	7500 (K)	
	for High Frequency Multilayer Type	LQG15H	1.0	0.5	0.5	10000 (D)	50000 (J)	1000 (B)
		LQG18H	1.6	0.8	0.8	4000 (D)	10000 (J)	1000 (B)
	for High Frequency Film Type	LQP02T	0.4	0.2	0.2	20000 (D)		500 (B)
		LQP03T_00/_04	0.6	0.3	0.3	10000 (D)	50000 (J)	500 (B)
		LQP03T_02	0.6	0.3	0.3	15000 (D)	50000 (J)	500 (B)
		LQP15T	1.0	0.5	0.4	10000 (D)		500 (B)
		LQP15M	1.0	0.5	0.35	10000 (D)	50000 (J)	500 (B)
		LQP18M	1.6	0.8	0.5	4000 (D)	10000 (J)	500 (B)
	for General Use Wire Wound Type	LQH31M	3.2	1.6	1.8	2000 (L)	7500 (K)	
		LQH32M	3.2	2.5	2.0	2000 (L)	7500 (K)	
		LQH43M/N	4.5	3.2	2.6	500 (L)	2500 (K)	
	DC-DC Converter Multilayer Type	LQM21P	2.0	1.25	0.5	4000 (D)		
LQM2MP		2.0	1.6	0.9	3000 (L)		1000 (B)	
LQM2HP_J0		2.5	2.0	1.1	3000 (D)		1000 (B)	
LQM2HP_G0		2.5	2.0	0.9	3000 (L)		1000 (B)	
LQM2HP_E0		2.5	2.0	0.7	3000 (D)		1000 (B)	
LQM31P_00		3.2	1.6	0.85	3000 (L)		1000 (B)	
LQM31P_C0		3.2	1.6	0.5	4000 (D)		1000 (B)	
DC-DC Converter Wire Wound Type	LQH2MC	2.0	1.6	0.9	3000 (L)		100 (B)	
	LQH3NP_M0	3.0	3.0	1.4	1000 (L)	4000 (K)		
	LQH3NP_J0	3.0	3.0	0.9	1000 (L)	5000 (K)		
	LQH3NP_G0	3.0	3.0	0.9	1500 (L)	6000 (K)		
	LQH32P	3.2	2.5	1.55	2000 (L)	7500 (K)		
	LQH44P	4.0	4.0	1.65	1000 (L)	3500 (K)		
	LQH55P	5.87	5.2	1.85	500 (L)	3000 (K)		
for General Use Multilayer Type	LQM18N	1.6	0.8	0.8	4000 (D)	10000 (J)	1000 (B)	
	LQM21N (0.1 to 2.2μH)	2.0	1.25	0.85	4000 (D)	10000 (J)	1000 (B)	
	LQM21N (2.7 to 4.7μH)	2.0	1.25	1.25	3000 (L)	10000 (K)	1000 (B)	
for Choke Wire Wound Type	LQH31C	3.2	1.6	1.8	2000 (L)	7500 (K)		
	LQH32C	3.2	2.5	2.0/1.55	2000 (L)	7500 (K)		
	LQH43C	4.5	3.2	2.6	500 (L)			
for Choke Multilayer Type	LQM18F	1.6	0.8	0.8	4000 (D)	10000 (J)	1000 (B)	
	LQM21D (1 to 10μH)	2.0	1.25	0.85	4000 (D)	10000 (J)	1000 (B)	
	LQM21D (22 to 47μH)	2.0	1.25	1.25	3000 (L)	10000 (K)	1000 (B)	
	LQM21F (1 to 2.2μH)	2.0	1.25	0.85	4000 (D)	10000 (J)	1000 (B)	
	LQM21F (4.7 to 47μH)	2.0	1.25	1.25	3000 (L)	10000 (K)	1000 (B)	
	LQM31F	3.2	1.6	1.0	3000 (L)	10000 (K)	1000 (B)	
for Choke Large Current Type	LQH55D	5.7	5.0	4.7	350 (L)	1500 (K)		
	LQH66S	6.3	6.3	4.7	350 (L)	1500 (K)		
● Micro Chip Transformer	Balun Film Type	DXP18B	1.6	0.8	0.45	5000 (L)		500 (B)
	Coupler Film Type	DXP18C	1.6	0.8	0.45	5000 (L)		500 (B)
	Balun Wire Wound Type	DXW21B	2.0	1.2	1.2	2000 (L)		500 (B)

● All dimensions given are nominal without mention.

△Note • This PDF catalog is downloaded from the website of Murata Manufacturing co., ltd. Therefore, it's specifications are subject to change or our products in it may be discontinued without advance notice. Please check with our sales representatives or product engineers before ordering.
• This PDF catalog has only typical specifications because there is no space for detailed specifications. Therefore, please approve our product specifications or transact the approval sheet for product specifications before ordering.

4 Resistors

Product Names	Part Number	Dimensions (mm)			Minimum Quantity (pcs.) (Packaging Code)					
		L	W	T	Ø180mm Reel	Ø330mm Reel	Bulk (Bag)	Ammo Pack	Magazine	Tray
● High Voltage Resistors	MHR*						1000			
● R Networks	RGLD*						1000	1000 (T2)		
	RGLE*						1000			
● Trimmer Potentiometers SMD Open Type 2mm Size	PVA2	2.75	2.2	0.8	3000 (R00)		1000 (B00)			
	PVZ2A	2.7	2.1	0.8	3000 (R00)		1000 (B00)			
	PVZ2R	4.8	2.1	0.8	3000 (R00)		1000 (B00)			
SMD Open Type 3mm Size	PVZ3A	3.6	3.1	1.85	2000 (R00)		1000 (B00)			
	PVZ3G	3.6	3.1	1.15	2500 (R00)		1000 (B00)			
	PVZ3K	5.4	3.1	2.1	1500 (R00)		1000 (B00)			
SMD Sealed Type 2mm Size	PVF2	2.15	2.0	2.3	500 (R00)		100 (B00)			
SMD Sealed Type 3mm Size	PVG3A/G	3.6	3.4	2.0	1000 (R00)		500 (B00)			
	PVG3K	3.6	3.4	(2.5)	500 (R00)					
SMD Sealed Type 4mm Size	PVM4	4.7	4.0	2.0	500 (R00)	3000 (R00)	500 (B00)			
SMD Sealed Type Multi Turns	PVG5A	5.0	4.8	3.9	250 (R00)		100 (B00)			
	PVG5H	4.9	4.8	3.7	500 (R00)		100 (B00)			
Lead Sealed Type Single Turn	PV32						300 (B00)			
Lead Sealed Type Multi Turns	PV12						50 (B00)			
	PV36P						100 (B00)		800 (M12)	
	PV36W						100 (B00)	1000 (A00)	1000 (M15)	
	PV36X						100 (B00)	1000 (A00)	800 (M15)	
	PV36Y						100 (B00)		1000 (M15)	
	PV36Z						100 (B00)		800 (M15)	
	PV37						100 (B00)	1000 ²⁾ (A00)		

1) Ammo Pack for PVC6M/Q Type.
2) Ammo Pack for PV37Y/Z Type.

5 Resonators

Product Names	Part Number	Dimensions (mm)			Minimum Quantity (pcs.) (Packaging Code)			
		L	W	T	Ø180mm Reel	Ø330mm Reel	Bulk (Bag)	Ammo Pack
● Crystal Resonators	XRCGA	2.0	1.6	0.7 max.	3000 (-R0)	9000 (-R1)		
● CERALOCK® (for Automotive) MHz Chip Type (Tight Frequency Tolerance)	CSTCR_G15C	4.5	2.0	1.2 max.	3000 (-R0)	9000 (-R1)	500 (-B0)	
	CSTCE_G15C	3.2	1.3	0.8 max.	3000 (-R0)	9000 (-R1)	500 (-B0)	
	CSTCE_V13C	3.2	1.3	1.0 max.	3000 (-R0)	9000 (-R1)	500 (-B0)	
MHz Chip Type (Standard Frequency Tolerance)	CSTCC_G_A	7.2	3.0	1.8 max. /1.6 max.	2000 (-R0)	6000 (-R1)	500 (-B0)	
	CSTCR_G_B	4.5	2.0	1.2 max.	3000 (-R0)	9000 (-R1)	500 (-B0)	
	CSTCE_G_A	3.2	1.3	0.8 max.	3000 (-R0)	9000 (-R1)	500 (-B0)	
	CSTCE_V_C	3.2	1.3	1.0 max.	3000 (-R0)	9000 (-R1)	500 (-B0)	
	CSTCV_X_Q	3.7	3.1	1.4 max.	2000 (-R0)	6000 (-R1)	500 (-B0)	
	CSACV_X_Q	3.7	3.1	1.4 max.	2000 (-R0)	6000 (-R1)	500 (-B0)	

Continued on the following page.

● All dimensions given are nominal without mention.

Note • This PDF catalog is downloaded from the website of Murata Manufacturing co., Ltd. Therefore, it's specifications are subject to change or our products in it may be discontinued without advance notice. Please check with our sales representatives or product engineers before ordering.
• This PDF catalog has only typical specifications because there is no space for detailed specifications. Therefore, please approve our product specifications or transact the approval sheet for product specifications before ordering.

Continued from the preceding page.

Product Names	Part Number	Dimensions (mm)			Minimum Quantity (pcs.) (Packaging Code)			
		L	W	T	Ø180mm Reel	Ø330mm Reel	Bulk (Bag)	Ammo Pack
● CERALOCK® (for General Usage) MHz Chip Type (Tight Frequency Tolerance)	CSTCR_G15L	4.5	2.0	1.2 max.	3000 (-R0)	9000 (-R1)	500 (-B0)	
	CSTCE_G15L	3.2	1.3	0.8 max.	3000 (-R0)	9000 (-R1)	500 (-B0)	
	CSTCE_V13L	3.2	1.3	1.0 max.	3000 (-R0)	9000 (-R1)	500 (-B0)	
	CSTCZ_X1_R	2.0	1.6	0.95 max.	3000 (-R0)	9000 (-R1)	500 (-B0)	
	CSTCW_X11	2.5	2.0	1.4 max.	3000 (-R0)	9000 (-R1)	500 (-B0)	
	CSTCE_XT	3.2	1.3	1.1 max.	3000 (-R0)	9000 (-R1)	500 (-B0)	
MHz Chip Type (Standard Frequency Tolerance)	CSTCC_G	7.2	3.0	1.8 max. /1.6 max.	2000 (-R0)	6000 (-R1)	500 (-B0)	
	CSTCR_G	4.5	2.0	1.2 max.	3000 (-R0)	9000 (-R1)	500 (-B0)	
	CSTCE_G	3.2	1.3	0.8 max.	3000 (-R0)	9000 (-R1)	500 (-B0)	
	CSTCE_V	3.2	1.3	1.0 max.	3000 (-R0)	9000 (-R1)	500 (-B0)	
	CSTCG_V	2.0	1.3	0.95 max.	3000 (-R0)	9000 (-R1)	500 (-B0)	
	CSTCW_X	2.5	2.0	1.4 max.	3000 (-R0)	9000 (-R1)	500 (-B0)	
	CSTCW_X_M	2.5	2.0	0.65 max.	3000 (-R0)	9000 (-R1)	500 (-B0)	
	CSACW_X	2.5	2.0	1.25 max.	3000 (-R0)	9000 (-R1)	500 (-B0)	
MHz Lead Type (Standard Frequency Tolerance)	CSTLS_G						500 (-B0)	2000 (-A0)
	CSTLS_X						500 (-B0)	2000 (-A0)
	CSALS_X						500 (-B0)	2000 (-A0)
kHz Chip Type (Standard Frequency Tolerance)	CSBFB_J (430-519kHz)	8.5	7.5	3.6 max.		1500 (-R1)	500 (-B0)	
	CSBFB_J (700-1250kHz)	6.0	5.0	2.5 max.		3000 (-R1)	1000 (-B0)	50 ¹⁾
kHz Lead Type (Standard Frequency Tolerance)	CSBLA_E (375-699kHz)						500 (-B0)	
	CSBLA_J (700-1250kHz)						1000 (-B0)	100 ¹⁾

1) Magazine

6 Filters for Audio Visual Equipment

Product Names	Part Number	Dimensions (mm)			Minimum Quantity (pcs.) (Packaging Code)				
		L	W	T	Ø180mm Reel	Ø330mm Reel	Bulk (Bag)	Ammo Pack	
● CERAFIL® kHz	Chip Type	SFPKA	8.4 max.	7.0	5.0 max.		1000 (-R1)		
	Lead Type	CFULA						200 (-B0)	
		CFWLA						150 (-B0)	
		SFPLA						200 (-B0)	
		SFULA						500 (-B0)	
		SFZLA						200 (-B0)	
● CERAFIL® MHz	Chip Type	SFSKB	5.2	3.6	1.5 max.		3000 (-R1)		
		SFSKA	8.5	3.8	2.0 max.		3000 (-R1)		
		SFECF	3.45	3.1	1.4 max.	2000 (-R0)			
		SFECV/SFECK	6.9	2.9	1.7 max.	2000 (-R0)			
	Lead Type	SFELF						500 (-B0)	1500 (-A0)
		SFELG						500 (-B0)	1500 (-A0)
		SFVLF						500 (-B0)	1000 (-A2)
	● Discriminators MHz	Chip Type	CDSCB	4.5	2.0	1.0 max.	2000 (-R0)		
Lead Type		CDALF						500 (-B0)	1500 (-A0)
● Traps MHz	Chip Type	TPSKA	8.5	3.8	2.0 max.		3000 (-R1)		
		TPWKA	8.5	5.0	1.7 max.		3000 (-R1)		
● SAW Traps for ISDB-T 1seg/DVB-H	Chip Type	SAEEA	1.35	1.05	0.5	4000 (R14)			
		SAEEB	1.35	1.05	0.6	4000 (R14)			
		SAEEN	1.8	1.35	0.5	4000 (R14)			

● All dimensions given are nominal without mention.

Note • This PDF catalog is downloaded from the website of Murata Manufacturing co., Ltd. Therefore, it's specifications are subject to change or our products in it may be discontinued without advance notice. Please check with our sales representatives or product engineers before ordering.
• This PDF catalog has only typical specifications because there is no space for detailed specifications. Therefore, please approve our product specifications or transact the approval sheet for product specifications before ordering.

7 Filters for Communication Equipment

Product Names	Part Number	Dimensions (mm)			Minimum Quantity (pcs.) (Packaging Code)		
		L	W	T	Ø180mm Reel	Ø330mm Reel	Bulk (Bag)
● Duplexers		Depends on each part number. Please contact us for details.					
Dielectric Duplexers (GIGAFIL®)	DFY						
SAW Duplexers	SAY						
● for RF/Local							
Dielectric Band Pass Filters (GIGAFIL®)	DFCH						
SAW Filters	SAFEA	1.35	1.05	0.5	4000 (R14)		
	SAFEB	1.35	1.05	0.6	4000 (R14)		
	SAWEN	1.8	1.35	0.5	4000 (R14)		
Chip Multilayer LC Filters (BPF)	LFB15	1.0	0.5	0.4 max.	10000		
	LFB18_SG	1.6	0.8	0.7 max.	4000		
	LFB2H_SG6	2.5	2.0	1.6 max.	2000		
	LFB2H_SG7	2.5	2.0	1.0 max.	3000		
	LFB21_SG8	2.0	1.25	1.05 max.	4000		
	LFB31_SG/SP	3.2	1.6	1.0-1.4 max.	3000		
Chip Multilayer LC Filters (LPF)	LFL15_TC	1.0	0.5	0.4 max.	10000		
	LFL18_TC	1.6	0.8	0.7 max.	4000		
	LFL21_TC	2.0	1.25	1.05 max.	4000		
Chip Multilayer LC Filters (Balance Filter)	LFB21_BA	2.0	1.25	1.0 max.	4000		
● for IF							
BGS Filters	MKFCC	3.0	3.0	1.15		5000 (R05)	
Ceramic Filters (CERAFIL®)	CFUKF	6.0	7.5 max.	4.0 max.	450 (-R0)		
	CFUKG	6.0	7.5 max.	4.0 max.	450 (-R0)		
	CFULA						200 (-B0)
	CFULB						250 (-B0)
	CFWKA	11.5	7.5 max.	3.0 max.	350 (-R0)		
	CFWLA						150 (-B0)
	CFWLB						150 (-B0)
	SFECF	3.45	3.1	1.4 max.	2000 (-R0)		
	SFPKA	7.0	8.4 max.	5.0 max.		1000 (-R1)	
	SFSCE	4.5	3.8	1.0 max.	1500 (-R0)		
Ceramic Discriminators	CDBKB	6.6	6.0	3.1 max.	500 (-R0)		
	CDBLA						500 (-B0)
	CDBLB						500 (-B0)
	CDSCB	4.5	2.0	1.0 max.	2000 (-R0)		

● All dimensions given are nominal without mention.

8 Microwave Components

Product Names	Part Number	Dimensions (mm)			Minimum Quantity (pcs.) (Packaging Code)			
		L	W	T	Ø180mm Reel	Ø330mm Reel	Bulk (Bag)	
● Isolators	CES20	3.2	2.5	1.2	1000 (RA1)	4000 (RB4)		
	CEG23	2.0	2.0	1.0	1000 (RA1)	5000 (RB5)		
	CES30	3.2	3.2	1.6	500 (RAB)	2000 (RB2)		
	CES32	3.2	3.2	1.5	500 (RAB)	3000 (RB3)		
	CES40	4.0	4.0	1.7	500 (RAB)	2000 (RB2)		
● Chip Multilayer Hybrid Couplers	Hybrid Dividers	LDD18	1.6	0.8	0.7 max.	4000		
		LDD21	2.0	1.25	1.05 max.	4000		
	Coupler	LDC15	1.0	0.5	0.4 max.	10000		
		LDC18	1.6	0.8	0.7 max.	4000		
		LDC21	2.0	1.25	1.05 max.	4000		
	3dB Hybrid	LDC32	3.2	2.5	1.00 max.	3000		
	Chip Multilayer Diplexers	LFD18_DP	1.6	0.8	0.7 max.	4000		
		LFD21_DP1, 2	2.0	1.25	1.05 max.	4000		
		LFD21_DP3, 4, F, G	2.0	1.25	1.0 max.	4000		
	● Chip Multilayer Hybrid Baluns	LDB18/LDM18	1.6	0.8	0.7 max.	4000		
LDB21		2.0	1.25	1.05 max.	4000			
● Chip Antennas	LDA21	2.0	1.25	1.0 max.	4000			
	LDA2H	2.3	1.8	4.0 max.		2000		
	LDA31	3.2	1.6	1.3 max.	3000			
	ANCG11G57SAA136	9.8	3.0	4.2 max.		1000		
	ANCG11G57SAA137	9.8	3.0	4.2 max.		1000		
	ANCG11G57SAA146	9.8	2.5	4.5 max.		1000		
	ANCG11G57SAA160	9.8	3.0	3.0 max.		2000		
	ANCG12G44SAA145	9.8	2.0	4.0 max.		1000		
	ANCG12G44SAA148	9.8	2.0	4.0 max.		1000		
	ANCV11G57SAA128	9.0	1.5	1.95 max.		3000		
	ANCV11G57SAA144	6.0	1.2	1.0 max.		5000		
● High Frequency Monolithic Ceramic Capacitors	High Frequency High-Q Type	GQM18	1.6	0.8	0.7/0.8	4000 (D)	10000 (J)	1000 (B)
		GQM21	2.0	1.25	0.85	4000 (D)	10000 (J)	1000 (B)
	High Frequency Type	ERB18	1.6	0.8	0.9 max.	4000 (D)	10000 (J)	1000 (B)
		ERB21	2.0	1.25	1.35 max.	3000 (L)	10000 (K)	1000 (B)
		ERB32	3.2	2.5	1.7 max.	2000 (L)	8000 (K)	1000 (B)
● Coaxial Connectors	MM4829-2702				4000 (RA4)	10000 (RB0)		
	MM9329-2700				1000 (RA1)	5000 (RB5)		
● Coaxial Connectors with Switches	MM8130-2600					8000 (RB8)		
	MM8430-2610				1000 (RA1)	3000 (RB3)		

Continued on the following page. 

● All dimensions given are nominal without mention.

 Note • This PDF catalog is downloaded from the website of Murata Manufacturing co., Ltd. Therefore, it's specifications are subject to change or our products in it may be discontinued without advance notice. Please check with our sales representatives or product engineers before ordering.
• This PDF catalog has only typical specifications because there is no space for detailed specifications. Therefore, please approve our product specifications or transact the approval sheet for product specifications before ordering.

Continued from the preceding page.

Product Names	Part Number	Dimensions (mm)			Minimum Quantity (pcs.) (Packaging Code)		
		L	W	T	Ø180mm Reel	Ø330mm Reel	Bulk (Bag)
● High Frequency Microchip Capacitors	CLB0A	0.25	0.25	0.35			100 ¹⁾ (TC1)
	CLB0B	0.30	0.25	0.35			100 ¹⁾ (TC1)
	CLB0C	0.35	0.25	0.35			100 ¹⁾ (TC1)
	CLB0D	0.38	0.38	0.35			100 ¹⁾ (TC1)
	CLB0E	0.55	0.38	0.35			100 ¹⁾ (TC1)
	CLB0H	0.71	0.38	0.35			100 ¹⁾ (TC1)
	CLB05	0.50	0.50	0.35			100 ¹⁾ (TC1)
	CLB0G	0.70	0.50	0.35			100 ¹⁾ (TC1)
	CLB0K	0.90	0.50	0.35			100 ¹⁾ (TC1)
	CLB0F	0.64	0.64	0.35			100 ¹⁾ (TC1)
	CLB1A	1.00	0.64	0.35			100 ¹⁾ (TC1)
	CLB0J	0.76	0.76	0.35			100 ¹⁾ (TC1)
	CLB1B	1.09	0.76	0.35			100 ¹⁾ (TC1)
	CLB09	0.90	0.90	0.35			100 ¹⁾ (TC1)
	CLB1E	1.49	0.90	0.35			100 ¹⁾ (TC1)
	CLB1C	1.27	1.27	0.35			50 ¹⁾ (TC1)
	CLB1G	1.73	1.27	0.35			50 ¹⁾ (TC1)
	CLB2C	2.19	1.27	0.45			50 ¹⁾ (TC1)
	CLB1H	1.78	1.78	0.45			50 ¹⁾ (TC1)
	CLB2L	2.95	1.78	0.45			50 ¹⁾ (TC1)
CLB2E	2.29	2.29	0.45			50 ¹⁾ (TC1)	
CLB3G	3.71	2.29	0.45			50 ¹⁾ (TC1)	

1) Tray

9 Sensors

Product Names	Part Number	Dimensions (mm)			Minimum Quantity (pcs.) (Packaging Code)				
		L	W	T	Ø180mm Reel	Ø330mm Reel	Bulk (Bag)	Ammo Pack	Tray
● POSISTOR® for Overheat Sensing Chip Type	PRF15	1.0	0.5	0.5	10000 (RC)				
	PRF18	1.6	0.8	0.8	4000 (RB)				
	PRF21	2.0	1.25	0.9	4000 (RA)				
Lead Type	PTFL						400 (B0)		
	PTFM						200 (B0)		
● Shock Sensors	PKGS-00LD	6.4	2.8	1.2	2000 (-R)				
	PKGS-90LD	6.4	2.8	2.1	1500 (-R)				
	PKGS-00MF/25MF	4.8	2.3	1.05	3000 (-R)				
	PKGS-25NB	3.8	2.0	1.05	3000 (-R)				
● Piezoelectric Gyroscopes (GYROSTAR®)	ENC-03R					2000 (-R)			
● MEMS Gyro	MEV-50A				200 (-R)				
● Rotary Position Sensors	SV01A	12.0	11.0	2.1		1000 (R00)	50 (B00)		
	SV01L	12.0	11.0	2.9					1000 (T00)
● Pyroelectric Infrared Sensors	IRS-*					1500 (-R1)			
● Magnetic Switch	AS-*				3000 (-R)				

● All dimensions given are nominal without mention.

10 Thermistors

Product Names	Part Number	Dimensions (mm)			Minimum Quantity (pcs.) (Packaging Code)					
		L	W	T	Ø180mm Reel	Ø330mm Reel	Bulk (Bag)	Ammo Pack	Magazine	Tray
● POSISTOR® for Motor Starters Plug-in Type	PTH7M/8M						50 ¹⁾			
● POSISTOR® for Circuit Protection Chip Type	PRG18	1.6	0.8	0.8	4000 (RB)					
	PRG21_RA	2.0	1.25	0.9	4000 (RA)					
	PRG21_RK	2.0	1.25	1.25	3000 (RK)					
Lead Type	PTGL*						refer to ²⁾ (B0)	refer to ³⁾ (A0)		
● POSISTOR® for Overheat Sensing Chip Type	PRF15	1.0	0.5	0.5	10000 (RC)					
	PRF18	1.6	0.8	0.8	4000 (RB)					
	PRF21	2.0	1.25	0.9	4000 (RA)					
Lead Type	PTFL						400			
	PTFM						200			
● NTC Thermistors for Temp. Sensor and Compensation	NCP03	0.6	0.3	0.3	15000 (RL)					
	NCP15	1.0	0.5	0.5	10000 (RC)					
	NCP18	1.6	0.8	0.8	4000 (RB)					
	NCP21	2.0	1.25	0.85	4000 (RA)					
● NTC Thermistors for Inrush Current Suppression	NTPA						refer to ⁴⁾ (B0)	refer to ⁵⁾ (A0)		

1) Box

2) 100 to 500pcs. are available. Please contact us for details.

3) 1,000 to 2,000pcs. are available. Please contact us for details.

4) 50 to 500pcs. are available. Please contact us for details.

5) 400 to 1,000pcs. are available. Please contact us for details.

12 Sound Components

Product Names	Part Number	Minimum Quantity (pcs.) (Packaging Code)				
		Ø330mm Reel	Bulk (Box)	Ammo Pack	Magazine	
● Piezoelectric Diaphragms* External Drive Types	7BB-12-9		5120			
	7BB-15-6		8000			
	7BB-20-3		3000			
	7BB-20-6		1800			
	7BB-20-6L0		600			
	7BB-27-4		1500			
	7BB-27-4L0		600			
	7BB-35-3		800			
	7BB-35-3L0		400			
	7BB-41-2		400			
	7BB-41-2L0		250			
	7NB-31R2-1		3000			
	Self Drive Types	7BB-20-6C		1800		
		7BB-20-6CL0		600		
7BB-27-4C			1500			
7BB-27-4CL0			600			
7BB-35-3C			800			
7BB-35-3CL0			400			
7BB-41-2C			600			
7BB-41-2CL0			250			
7SB-34R7-3C		800				

Continued on the following page. 

● All dimensions given are nominal without mention.

△Note • This PDF catalog is downloaded from the website of Murata Manufacturing co., Ltd. Therefore, it's specifications are subject to change or our products in it may be discontinued without advance notice. Please check with our sales representatives or product engineers before ordering.

• This PDF catalog has only typical specifications because there is no space for detailed specifications. Therefore, please approve our product specifications or transact the approval sheet for product specifications before ordering.

Continued from the preceding page.

Product Names	Part Number	Minimum Quantity (pcs.) (Packaging Code)			
		Ø330mm Reel	Bulk (Box)	Ammo Pack	Magazine
● Piezoelectric Sounders* External Drive Types	PKLCS1212E4001-R1	1000			
	PKLCS1212E40A1-R1	1000			
	PKLCS1212E2000-R1	1000			
	PKLCS1212E20A0-R1	1000			
	PKM13EPYH4000-A0			500	
	PKM13EPYH4002-B0		330		
	PKM17EPP-2002-B0		200		
	PKM17EPPH4001-B0		200		
	PKM17EWH2001		250		
	PKM17EWH4000		500		
	PKM22EPH2001		360		
	PKM22EPPH2001-B0		750		
	PKM22EPPH4001-B0		900		
	PKM22EPPH4005-B0		750		
	PKM22EPPH4007-B0		750		
	PKM22EPTH2001-B0		300		75 ¹⁾
Self Drive Types	PKM24SPH3805		360		
	PKM30SPTH2001-B0		70		
	PKM30SPTH2501-B0		70		
● Piezoelectric Buzzers*	PKB24SPCH3601-B0		650		
	PKB24SWH3301		200		
● Piezoelectric Ringers (PIEZORINGER®)*	PKM33EPH1201C		300		
	PKM34EWH1101C		25		
	PKM34EWH1201C		25		
	PKM44EWH1001C		25		

1) The last two digits are changed to M0.

● All dimensions given are nominal without mention.

1

Capacitors

Monolithic Ceramic Capacitors

Monolithic Ceramic Capacitors for Medium Voltage

Monolithic Ceramic Capacitors Safety Standard Certified

Monolithic Ceramic Capacitors (Lead Type)

High Voltage Ceramic Capacitors (250V-6.3kV)

Safety Standard Certified Ceramic Capacitors

High Voltage Ceramic Capacitors (10-40kV)

Ceramic Trimmer Capacitors

● Part Numbering

Chip Monolithic Ceramic Capacitors



① Product ID

② Series

Product ID	Code	Series
GR	M	Tin Plated Layer
	4	Only for Information Devices
	7	Only for Camera Flash Circuit
ER	B	High Frequency Type
GQ	M	High Frequency for Flow/Reflow Soldering
GM	A	Monolithic Microchip
	D	for Bonding
GN	M	Capacitor Array
LL	L	Low ESL Wide Width Type
	A	Eight-termination Low ESL Type
	M	Ten-termination Low ESL Type
GJ	M	High Frequency Low Loss Type
GA	2	for AC250V (r.m.s.)
	3	Safety Standard Certified Type
GC	M	Automotive Tin Plated Layer

③ Dimension (L×W)

Code	Dimension (L×W)	EIA
02	0.4×0.2mm	01005
03	0.6×0.3mm	0201
05	0.5×0.5mm	0202
08	0.8×0.8mm	0303
0D	0.38×0.38mm	015015
0M	0.9×0.6mm	0302
11	1.25×1.0mm	0504
15	1.0×0.5mm	0402
18	1.6×0.8mm	0603
1M	1.37×1.0mm	0504
21	2.0×1.25mm	0805
22	2.8×2.8mm	1111
31	3.2×1.6mm	1206
32	3.2×2.5mm	1210
42	4.5×2.0mm	1808
43	4.5×3.2mm	1812
52	5.7×2.8mm	2211
55	5.7×5.0mm	2220

④ Dimension (T)

Code	Dimension (T)
2	0.2mm
2	2-elements (Array Type)
3	0.3mm
4	4-elements (Array Type)
5	0.5mm
6	0.6mm
7	0.7mm
8	0.8mm
9	0.85mm
A	1.0mm
B	1.25mm
C	1.6mm
D	2.0mm
E	2.5mm
F	3.2mm
M	1.15mm
N	1.35mm
Q	1.5mm
R	1.8mm
S	2.8mm
X	Depends on individual standards.

With the array type GNM series, "Dimension(T)" indicates the number of elements.

Continued on the following page.

Continued from the preceding page.

⑤ Temperature Characteristics

Temperature Characteristic Codes			Temperature Characteristics			Operating Temperature Range
Code	Public STD Code		Reference Temperature	Temperature Range	Capacitance Change or Temperature Coefficient	
1X	SL *1	JIS	20°C	20 to 85°C	+350 to -1000ppm/°C	-55 to 125°C
2C	CH *1	JIS	20°C	20 to 125°C	0±60ppm/°C	-55 to 125°C
2P	PH *1	JIS	20°C	20 to 85°C	-150±60ppm/°C	-25 to 85°C
2R	RH *1	JIS	20°C	20 to 85°C	-220±60ppm/°C	-25 to 85°C
2S	SH *1	JIS	20°C	20 to 85°C	-330±60ppm/°C	-25 to 85°C
2T	TH *1	JIS	20°C	20 to 85°C	-470±60ppm/°C	-25 to 85°C
3C	CJ *1	JIS	20°C	20 to 125°C	0±120ppm/°C	-55 to 125°C
3P	PJ *1	JIS	20°C	20 to 85°C	-150±120ppm/°C	-25 to 85°C
3R	RJ *1	JIS	20°C	20 to 85°C	-220±120ppm/°C	-25 to 85°C
3S	SJ *1	JIS	20°C	20 to 85°C	-330±120ppm/°C	-25 to 85°C
3T	TJ *1	JIS	20°C	20 to 85°C	-470±120ppm/°C	-25 to 85°C
3U	UJ *1	JIS	20°C	20 to 85°C	-750±120ppm/°C	-25 to 85°C
4C	CK *1	JIS	20°C	20 to 125°C	0±250ppm/°C	-55 to 125°C
5C	COG *1	EIA	25°C	25 to 125°C	0±30ppm/°C	-55 to 125°C
5G	X8G *1	EIA	25°C	25 to 150°C	0±30ppm/°C	-55 to 150°C
6C	COH *1	EIA	25°C	25 to 125°C	0±60ppm/°C	-55 to 125°C
6P	P2H *1	EIA	25°C	25 to 85°C	-150±60ppm/°C	-55 to 125°C
6R	R2H *1	EIA	25°C	25 to 85°C	-220±60ppm/°C	-55 to 125°C
6S	S2H *1	EIA	25°C	25 to 85°C	-330±60ppm/°C	-55 to 125°C
6T	T2H *1	EIA	25°C	25 to 85°C	-470±60ppm/°C	-55 to 125°C
7U	U2J *1	EIA	25°C	25 to 125°C *6	-750±120ppm/°C	-55 to 125°C
B1	B *2	JIS	20°C	-25 to 85°C	±10%	-25 to 85°C
B3	B	JIS	20°C	-25 to 85°C	±10%	-25 to 85°C
C7	X7S	EIA	25°C	-55 to 125°C	±22%	-55 to 125°C
C8	X6S	EIA	25°C	-55 to 105°C	±22%	-55 to 105°C
D7	X7T	EIA	25°C	-55 to 125°C	+22, -33%	-55 to 125°C
D8	X6T	EIA	25°C	-55 to 105°C	+22, -33%	-55 to 105°C
E7	X7U	EIA	25°C	-55 to 125°C	+22, -56%	-55 to 125°C
F1	F *2	JIS	20°C	-25 to 85°C	+30, -80%	-25 to 85°C
F5	Y5V	EIA	25°C	-30 to 85°C	+22, -82%	-30 to 85°C
L8	X8L	*3	25°C	-55 to 150°C	+15, -40%	-55 to 150°C
R1	R *2	JIS	20°C	-55 to 125°C	±15%	-55 to 125°C
R3	R	JIS	20°C	-55 to 125°C	±15%	-55 to 125°C
R6	X5R	EIA	25°C	-55 to 85°C	±15%	-55 to 85°C
R7	X7R	EIA	25°C	-55 to 125°C	±15%	-55 to 125°C
R9	X8R	EIA	25°C	-55 to 150°C	±15%	-55 to 150°C
W0	-	-	25°C	-55 to 125°C	±10% *4	-55 to 125°C
					+22, -33% *5	

*1 Please refer to table for Capacitance Change under reference temperature.

*2 Capacitance change is specified with 50% rated voltage applied.

*3 Murata Temperature Characteristic Code.

*4 Apply DC350V bias.

*5 No DC bias.

*6 Rated Voltage 100Vdc max.: 25 to 85°C

Continued on the following page. 

Continued from the preceding page.

● Capacitance Change from each temperature

JIS Code

Murata Code	Capacitance Change from 20°C (%)					
	-55°C		-25°C		-10°C	
	Max.	Min.	Max.	Min.	Max.	Min.
1X	-	-	-	-	-	-
2C	0.82	-0.45	0.49	-0.27	0.33	-0.18
2P	-	-	1.32	0.41	0.88	0.27
2R	-	-	1.70	0.72	1.13	0.48
2S	-	-	2.30	1.22	1.54	0.81
2T	-	-	3.07	1.85	2.05	1.23
3C	1.37	-0.90	0.82	-0.54	0.55	-0.36
3P	-	-	1.65	0.14	1.10	0.09
3R	-	-	2.03	0.45	1.35	0.30
3S	-	-	2.63	0.95	1.76	0.63
3T	-	-	3.40	1.58	2.27	1.05
3U	-	-	4.94	2.84	3.29	1.89
4C	2.56	-1.88	1.54	-1.13	1.02	-0.75

EIA Code

Murata Code	Capacitance Change from 25°C (%)					
	-55°C		-30°C		-10°C	
	Max.	Min.	Max.	Min.	Max.	Min.
5C/5G	0.58	-0.24	0.40	-0.17	0.25	-0.11
6C	0.87	-0.48	0.59	-0.33	0.38	-0.21
6P	2.33	0.72	1.61	0.50	1.02	0.32
6R	3.02	1.28	2.08	0.88	1.32	0.56
6S	4.09	2.16	2.81	1.49	1.79	0.95
6T	5.46	3.28	3.75	2.26	2.39	1.44
7U	8.78	5.04	6.04	3.47	3.84	2.21

Continued on the following page.

 Continued from the preceding page.

⑥ Rated Voltage

Code	Rated Voltage
0E	DC2.5V
0G	DC4V
0J	DC6.3V
1A	DC10V
1C	DC16V
1E	DC25V
YA	DC35V
1H	DC50V
2A	DC100V
2D	DC200V
2E	DC250V
YD	DC300V
2H	DC500V
2J	DC630V
3A	DC1kV
3D	DC2kV
3F	DC3.15kV
BB	DC350V (for Camera Flash Circuit)
E2	AC250V
GB	X2; AC250V (Safety Standard Certified Type GB)
GC	X1/Y2; AC250V (Safety Standard Certified Type GC)
GD	Y3; AC250V (Safety Standard Certified Type GD)
GF	Y2, X1/Y2; AC250V (Safety Standard Certified Type GF)

⑦ Capacitance

Expressed by three-digit alphanumerics. The unit is pico-farad (pF). The first and second figures are significant digits, and the third figure expresses the number of zeros which follow the two numbers. If there is a decimal point, it is expressed by the capital letter "R". In this case, all figures are significant digits.

Ex.)

Code	Capacitance
R50	0.5pF
1R0	1.0pF
100	10pF
103	10000pF

Continued on the following page. 

Continued from the preceding page.

8 Capacitance Tolerance

Code	Capacitance Tolerance	TC	Series	Capacitance Step	
W	±0.05pF	CΔ	GRM/GJM	≤9.9pF	0.1pF
B	±0.1pF	CΔ	GRM/GJM	≤9.9pF	0.1pF
			GQM	≤1pF	0.1pF
			ERB	≤9.9pF	1pF step and E24 Series
C	±0.25pF	CΔ	GRM/GJM	≤9.9pF	0.1pF
		except CΔ	GRM	≤5pF	* 1pF
		CΔ	ERB	≤9.9pF	1pF step and E24 Series
			GQM	≤1pF	0.1pF
D	±0.5pF	CΔ	GRM/GJM	5.1 to 9.9pF	0.1pF
		except CΔ	GRM	5.1 to 9.9pF	* 1pF
		CΔ	ERB/GQM	5.1 to 9.9pF	1pF step and E24 Series
G	±2%	CΔ	GJM	≥10pF	E12 Series
		CΔ	GQM/ERB	≥10pF	E24 Series
J	±5%	CΔ-SL	GRM/GA3	≥10pF	E12 Series
		CΔ	ERB/GQM/GJM	≥10pF	E24 Series
		U2J	GCM		E6 Series
K	±10%	B, R, X7R, X5R, ZLM	GRM/GR7/GA3		E6 Series
		C0G	GNM		E6 Series
		B, R, X7R, X5R, ZLM	GR4, GMD		E12 Series
M	±20%	B, R, X7R, X7S	GRM/GMA		E6 Series
		X5R, X7R, X7S	GNM		E3 Series
		X7R	GA2		E3 Series
		X5R, X7R, X7S, X6S	LLL/LLA/LLM		E3 Series
Z	+80%, -20%	F, Y5V	GRM		E3 Series
R			Depends on individual standards.		

* E24 series is also available.

9 Individual Specification Code

Expressed by three figures.

10 Packaging

Code	Packaging
L	ø180mm Embossed Taping
D	ø180mm Paper Taping
E	ø180mm Paper Taping (LLL15)
K	ø330mm Embossed Taping
J	ø330mm Paper Taping
F	ø330mm Paper Taping (LLL15)
B	Bulk
C	Bulk Case
T	Bulk Tray

Radial Lead Type Monolithic Ceramic Capacitors

(Part Number) **RP** **E** **R7** **1H** **104** **K** **2** **M1** **A03** **A**
 ① ② ③ ④ ⑤ ⑥ ⑦ ⑧ ⑨ ⑩

① Product ID / ② Series/Terminal

Product ID	Series/Terminal	
RP	E	Radial Lead Type Monolithic Ceramic Capacitors (DC25V-DC100V)
RH	E/D	Radial Lead Type Monolithic Ceramic Capacitors 150°C max. (for Automotive) (DC50V-DC100V)
RD	E	Radial Lead Type Monolithic Ceramic Capacitors (Only for Commercial Use) (DC250V-DC630V)

③ Temperature Characteristics

Code	Temperature Characteristics	Temperature Range	Capacitance Change or Temperature Coefficient	Operating Temperature Range
5C	C0G	25 to 125°C	0±30ppm/°C	-55 to 125°C
F5	Y5V	-30 to 85°C	+22, -82%	-30 to 85°C
L8	X8L	-55 to 125°C	±15%	-55 to 150°C
		125 to 150°C	+15, -40%	
R7	X7R	-55 to 125°C	±15%	-55 to 125°C

④ Rated Voltage

Code	Rated Voltage
1E	DC25V
1H	DC50V
2A	DC100V
2E	DC250V
2J	DC630V

⑥ Capacitance Tolerance

Code	Capacitance Tolerance	Temperature Characteristics	Capacitance Step
C	±0.25pF	C0G	≤5pF : 1pF Step
D	±0.5pF		6 to 9pF : 1pF Step
J	±5%		≥10 : E12 Series
K	±10%	X7R	E6 Series
M	±20%	Z5U	E3 Series
Z	+80%, -20%	Y5V	E3 Series

⑦ Dimensions (LxW)

Code	Dimensions (LxW)
1	4.0×3.5mm
2	5.0×3.5mm or 5.5×4.0mm or 5.7×4.5mm (Depends on Part Number List)
3	5.0×4.5mm or 5.5×5.0mm (Depends on Part Number List)
4	7.5×5.0mm
5	7.5×7.5mm*
6	10.0×10.0mm
7	12.5×12.5mm
8	7.5×5.5mm
U	7.7×12.5mm*

* DC630V: W+0.5mm

⑤ Capacitance

Expressed by three figures. The unit is pico-farad (pF). The first and second figures are significant digits, and the third figure expresses the number of zeros which follow the two numbers. If there is a decimal point, it is expressed by the capital letter "R". In this case, all figures are significant digits.

⑧ Lead Style

Code	Lead Style	Lead Spacing
A2	Straight Long	2.5mm
B1	Straight Long	5.0mm
C1	Straight Long	10.0mm
DB	Straight Taping	2.5mm
E1/E2	Straight Taping	5.0mm
K1	Inside Crimp	5.0mm
M1/M2	Inside Crimp Taping	5.0mm
P1	Outside Crimp	2.5mm
S1/S2	Outside Crimp Taping	2.5mm

Lead distance between reference and bottom planes.

M1, S1 : H₀ = 16.0±0.5mm

M2, S2 : H₀ = 20.0±0.5mm

E1 : H = 17.5±0.5mm

E2 : H = 20.0±0.5mm

⑨ Individual Specification Code

Expressed by three figures.

⑩ Packaging

Code	Packaging
A	Ammo Pack
B	Bulk

△Note • This PDF catalog is downloaded from the website of Murata Manufacturing co., Ltd. Therefore, it's specifications are subject to change or our products in it may be discontinued without advance notice. Please check with our sales representatives or product engineers before ordering.
 • This PDF catalog has only typical specifications because there is no space for detailed specifications. Therefore, please approve our product specifications or transact the approval sheet for product specifications before ordering.

High Voltage Ceramic Capacitors (250V-6.3kV)

(Part Number) **DE** **B** **B3** **3A** **102** **K** **N2** **A**
 ① ② ③ ④ ⑤ ⑥ ⑦ ⑧ ⑨

① Product ID

Product ID	
DE	High Voltage Ceramic Capacitors (250V - 6.3kV) / Safety Standard Certified Ceramic Capacitors

② Series Category

Code	Outline	Contents
A	High Voltage	Class 1 (char. SL) DC1-3.15kV Rated
B		Class 2 DC1-3.15kV Rated
C		Class 1, 2 DC6.3kV Rated
H		High Temperature Guaranteed, Low-dissipation Factor (char. R, C)
S		High Temperature Guaranteed, Low-dissipation Factor (char. D)
F		LCD Backlight Inverter Circuit/6.3kVp-p

First three digits (①Product ID and ②Series Category) express "Series Name".

③ Temperature Characteristics

Code	Temperature Characteristics	Cap. Change or Temp. Coeff.	Temperature Range
B3	B	±10%	-25 to +85°C
E3	E	+20%, -55%	
F3	F	+30%, -80%	
C3	C	±20%	-25 to +85°C
		+15%, -30%	+85 to +125°C
R3	R	±15%	-25 to +85°C
		+15%, -30%	+85 to +125°C
D3	D	+20%, -30%	-25 to +125°C
1X	SL	+350 to -1000ppm/°C	+20 to +85°C
2C	CH	0±60ppm/°C	+20 to +85°C

④ Rated Voltage

Code	Rated Voltage
2E	DC250V
2H	DC500V
3A	DC1kV
3D	DC2kV
3F	DC3.15kV
3J	DC6.3kV
LH	6.3kVp-p

⑤ Capacitance

Expressed by three figures. The unit is pico-farad (pF). The first and second figures are significant digits, and the third figure expresses the number of zeros which follow the two numbers.

⑥ Capacitance Tolerance

Code	Capacitance Tolerance
C	±0.25pF
D	±0.5pF
J	±5%
K	±10%
Z	+80%, -20%

⑦ Lead Style

Code	Lead Style	Dimensions(mm)		
		Lead Spacing	Lead Diameter	Pitch of Components
A2	Vertical Crimp Long	5	ø0.6±0.05	-
A3		7.5		
A4		10		
B2/J2	Vertical Crimp Short	5	ø0.6±0.05	-
B3/J3		7.5		
B4		10		
C1	Straight Long	5	ø0.5±0.05	-
C3		7.5	ø0.6±0.05	
C4		10	ø0.5±0.05	
CD		7.5	ø0.5±0.05	
D1	Straight Short	5	ø0.5±0.05	-
D3		7.5	ø0.6±0.05	
DD		7.5	ø0.5±0.05	
N2	Vertical Crimp Taping	5	ø0.6±0.05	12.7
N3		7.5		15
N7		7.5		30
P2	Straight Taping	5	ø0.6±0.05	12.7
P3		7.5		15

⑧ Packaging

Code	Packaging
A	Ammo Pack
B	Bulk

⑨ Individual Specification Code

In case part number cannot be identified without "Individual Specification", it is added at the end of part number. Expressed by three-digit alphanumerics.

Safety Standard Certified Ceramic Capacitors

(Part Number) **DE** **2** **E3** **KH** **102** **M** **N3** **A**
 ① ② ③ ④ ⑤ ⑥ ⑦ ⑧ ⑨

① Product ID

Product ID	
DE	High Voltage Ceramic Capacitors (250V - 6.3kV) / Safety Standard Certified Ceramic Capacitors

② Series Category

Code	Outline	Contents
1	Safety Standard Certified	IEC60384-14 Class X1, Y1
2		IEC60384-14 Class X1, Y2
J	AC250V (r.m.s.)	"Products which are based on the Electrical Appliance and Material Safety Law of Japan"

In case of Electrical Appliance and Material Safety Law of Japan, first three digits (①Product ID and ②Series Category) express "Series Name".
 In case of Safety Certified Capacitors, first three digits express product code. The following fourth figure expresses certified type shown in ④Safety Standard Certified Type column.

③ Temperature Characteristics

Code	Temperature Characteristics	Cap.Change or Temp. Coeff.	Temperature Range
B3	B	±10%	-25 to +85°C
E3	E	+20%, -55%	
F3	F	+30%, -80%	
1X	SL	+350 to -1000ppm/°C	+20 to +85°C

④ Rated Voltage/Safety Standard Certified Type

Code	Rated Voltage
E2	AC250V
KH	X1, Y2; AC250V, (Safety Standard Certified Type KH)
KY	X1, Y2; AC250V, (Safety Standard Certified Type KY)
KX	X1, Y1; AC250V, (Safety Standard Certified Type KX)

⑤ Capacitance

Expressed by three figures. The unit is pico-farad (pF). The first and second figures are significant digits, and the third figure expresses the number of zeros which follow the two numbers.

⑥ Capacitance Tolerance

Code	Capacitance Tolerance
J	±5%
K	±10%
M	±20%
Z	+80%, -20%

⑦ Lead Style

Code	Lead Style	Dimensions (mm)			
		Lead Spacing	Lead Diameter	Pitch of Components	
A2	Vertical Crimp Long	5	ø0.6±0.05	-	
A3		7.5			
A4		10			
A5		10	ø0.6+0.1, -0.05		
B2	Vertical Crimp Short	5	ø0.6±0.05	-	
B3		7.5			
B4		10			
B5		10	ø0.6+0.1, -0.05		
C3	Straight Long	7.5	ø0.6±0.05	-	
D3	Straight Short	7.5	ø0.6±0.05	-	
N2	Vertical Crimp Taping	5	ø0.6±0.05	12.7	
N3		7.5		15	
N4		10		25.4	
N5		10		ø0.6+0.1, -0.05	25.4
N7		7.5		ø0.6±0.05	30
P3	Straight Taping	7.5	ø0.6±0.05	15	

⑧ Packaging

Code	Packaging
A	Ammo Pack
B	Bulk

⑨ Individual Specification

In case part number cannot be identified without "Individual Specification", it is added at the end of part number. Expressed by three figures.

△Note • This PDF catalog is downloaded from the website of Murata Manufacturing co., ltd. Therefore, it's specifications are subject to change or our products in it may be discontinued without advance notice. Please check with our sales representatives or product engineers before ordering.
 • This PDF catalog has only typical specifications because there is no space for detailed specifications. Therefore, please approve our product specifications or transact the approval sheet for product specifications before ordering.

High Voltage Ceramic Capacitors (over 10kV)

(Part Number) **DH** **S** **4E** **4D** **142** **K** **L2** **B**
 ① ② ③ ④ ⑤ ⑥ ⑦ ⑧

① Product ID

Product ID	
DH	High Voltage Ceramic Capacitors (over 10kV)

② Series Category

Code	Contents
S	Mold Type

First three digits of part number (①Product ID and ②Series Category) express "Series Name".

③ Temperature Characteristics

Code	Temp. Char.	Cap. Change or Temp. Coeff.	Temp. Range
F4	Z5V	+22%, -82%	+10 to +85°C
4E	N4700	-4700±1000ppm/°C	+20 to +85°C

④ Rated Voltage

Code	Rated Voltage
4A	DC10kV
4C	DC15kV
4D	DC20kV
4F	DC30kV
4G	DC40kV

⑤ Capacitance

Expressed by three figures. The unit is pico-farad (pF). The first and second figures are significant digits, and the third figure expresses the number of zeros which follow the two numbers.

⑥ Capacitance Tolerance

Code	Capacitance Tolerance
K	±10%
M	±20%
Z	+80%, -20%

⑦ Body Diameter and Terminal Type

Code	Body Diameter	Terminal Type
C2	20mm	ISO M4, P0.7 Tapped Holes (Metric Screw Thread)
D2	24mm	
H2	30mm	
L2	38mm	
N2	43mm	
R2	52mm	
T2	60mm	No.8-32, NC-2B Tapped Holes (Inch Screw Thread)
CX	20mm	
DX	24mm	
HX	30mm	
LX	38mm	
NX	43mm	
RX	52mm	
TX	60mm	

⑧ Packaging

Code	Packaging
B	Bulk

⚠️Note • This PDF catalog is downloaded from the website of Murata Manufacturing co., Ltd. Therefore, it's specifications are subject to change or our products in it may be discontinued without advance notice. Please check with our sales representatives or product engineers before ordering.
 • This PDF catalog has only typical specifications because there is no space for detailed specifications. Therefore, please approve our product specifications or transact the approval sheet for product specifications before ordering.

Ceramic Trimmer Capacitors

(Part Number)

TZ	Y2	R	200	A	001	R00
①	②	③	④	⑤	⑥	⑦

① Product ID

② Series/Terminal

Code	Series/Terminal
03	6mm Size Lead Type
B4	4mm Size SMD/Lead Type
W4	4mm Size SMD Type
C3	3mm Size SMD Type
S2	2mm Size SMD Type (Height 1.0mm)
Y2	2mm Size SMD Type (Height 1.25mm)
V2	2mm Size SMD Type (Height 1.45mm)
R1	1mm Size SMD Type (Height 0.90mm)

③ Temperature Characteristics

④ Maximum Capacitance

Expressed by three-digit alphanumerics. The unit is pico-farad (pF). The first and second figures are significant digits, and the third figure expresses the number of zeros which follow the two numbers. If there is a decimal point, it is expressed by the capital letter "R". In this case, all figures are significant digits.

⑤ Terminal Shape

⑥ Individual Specification

Code	Individual Specifications
001	TZR1, TZS2, TZY2, TZW4 Standard Type
110	TZV2, TZC3 (Minus Slot) Standard Type
169	TZ03 Standard Type
310	TZC3 (Plus Slot) Standard Type
A10	TZB4 No-cover Film Standard Type
B10	TZB4 with Cover Film Standard Type

⑦ Packaging

△Note • This PDF catalog is downloaded from the website of Murata Manufacturing co., ltd. Therefore, it's specifications are subject to change or our products in it may be discontinued without advance notice. Please check with our sales representatives or product engineers before ordering.
• This PDF catalog has only typical specifications because there is no space for detailed specifications. Therefore, please approve our product specifications or transact the approval sheet for product specifications before ordering.

Monolithic Ceramic Capacitors

	Series	Dimensions (mm)	Capacitance Range (F)												
			0.1p	1p	10p	100p	1000p	0.01μ	0.1μ	1μ	10μ	100μ			
For General Electronics Equipment	GRM02	0.4X0.2	0.2pF							0.01μF					
	GRM03	0.6X0.3	0.1pF							0.047μF					
	GRM15	1.0X0.5	0.1pF									4.7μF			
	GRM18	1.6X0.8			10pF								10μF		
	GRM21	2.0X1.25				100pF							22μF		
	GRM31	3.2X1.6					1800pF							100μF	
For Automotive	GCM03	0.6X0.3		1pF						0.01μF					
	GCM15	1.0X0.5		1pF						0.1μF					
	GCM18	1.6X0.8		1pF							2.2μF				
	GCM21	2.0X1.25				100pF							10μF		
	GCM31	3.2X1.6					1800pF						22μF		
	GCM32	3.2X2.5								1.0μF			47μF		
Array	GNM0M	0.9X0.6						0.01μF		1.0μF					
	GNM1M	1.37X1.0			10pF					2.2μF					
	GNM21	2.0X1.25			10pF					2.2μF					
	GNM31	3.2X1.6			10pF					1.0μF					
Low ESL	LLL15	0.5X1.0								0.1μF		0.47μF			
	LLL18	0.8X1.6					2200pF					2.2μF			
	LLL21	1.25X2.0								0.01μF		2.2μF			
	LLL31	1.6X3.2								0.01μF		10μF			
	LLA18	1.6X0.8								0.1μF		2.2μF			
	LLA21	2.0X1.25								0.01μF		4.7μF			
	LLA31	3.2X1.6								0.1μF		2.2μF			
	LLM21	2.0X1.25								0.01μF		2.2μF			
	LLM31	3.2X1.6								0.1μF		2.2μF			
High-Q	GJM03	0.6X0.3	0.2pF			33pF									
	GJM15	1.0X0.5	0.1pF			20pF									
High Frequency Series	GQM18	1.6X0.8	0.1pF			100pF									
	GQM21	2.0X1.25				100pF									
	ERB18	1.6X0.8		0.5pF		100pF									
	ERB21	2.0X1.25		0.5pF		100pF									
	ERB32	3.2X2.5		0.5pF		160pF									
Micro Chip	GMA0D	0.38X0.38								0.01μF					
	GMA05	0.5X0.5				100pF				0.1μF					
	GMA08	0.8X0.8					1500pF			0.47μF					
	GMD03	0.6X0.3				100pF				0.1μF					
	GMD15	1.0X0.5					220pF			1.0μF					
Medium Voltage	GRM (Low Dissipation)	2.0X1.25-4.5X2.0	Rated Voltage												
			DC250V			100pF				0.01μF					
			DC630V		10pF			2200pF							
	GRM (High Capacitance)	1.6X0.8-5.7X5.0	DC250V				220pF				1μF				
			DC630V					1000pF			0.22μF				
	GRM (for LCD Backlight Inverter Circuit)	4.5X2.0	DC3.15kV		5pF						47pF				
GR4 (for Information Devices)	4.5X2.0-5.7X5.0	DC2kV								100pF			0.01μF		
GR7 (for Camera Flash Circuit)	3.2X1.6	DC350V								0.01μF			0.047μF		
GCM (Automotive Low Dissipation)	2.0X1.25-3.2X2.5	DC250V					100pF			0.01μF					
			DC630V		10pF			2200pF							
AC250V	GA2	4.5X2.0-5.7X5.0	AC250V							470pF			0.1μF		
Safety Standard Certified	GA3 (Type GC)	5.7X5.0	Class / Rated Voltage	X1,Y2/AC250V						100pF			330pF		
				Y3/AC250V		10pF						4700pF			
				Y2/AC250V		10pF							4700pF		
				X1,Y2/AC250V						470pF			4700pF		
				X2/AC250V								0.01μF			0.056μF

26 Note • This PDF catalog is downloaded from the website of Murata Manufacturing co., Ltd. Therefore, it's specifications are subject to change or our products in it may be discontinued without advance notice. Please check with our sales representatives or product engineers before ordering. • This PDF catalog has only typical specifications because there is no space for detailed specifications. Therefore, please approve our product specifications or transact the approval sheet for product specifications before ordering.

Monolithic Ceramic Capacitors

for General Purpose GRM Series

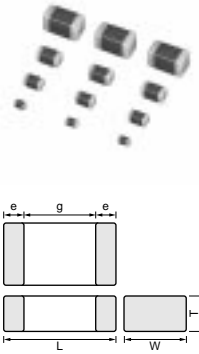

Part Number	Dimensions (mm)				
	L	W	T	e	g min.
GRM022	0.4 ±0.02	0.2 ±0.02	0.2 ±0.02	0.07 to 0.14	0.13
GRM033	0.6 ±0.03	0.3 ±0.03	0.3 ±0.03	0.1 to 0.2	0.2
GRM15X			0.25 ±0.05		
GRM153	1.0 ±0.05	0.5 ±0.05	0.3 ±0.03	0.1 to 0.3	0.4
GRM155			0.5 ±0.05	0.15 to 0.35	0.3
GRM185	1.6 ±0.1	0.8 ±0.1	0.5 ±0/-0.1	0.2 to 0.5	0.5
GRM188*			0.8 ±0.1		
GRM216			0.6 ±0.1		
GRM219	2.0 ±0.1	1.25 ±0.1	0.85 ±0.1	0.2 to 0.7	0.7
GRM21A			1.0 ±0/-0.2		
GRM21B			1.25 ±0.1		
GRM316			0.6 ±0.1		
GRM319	3.2 ±0.15	1.6 ±0.15	0.85 ±0.1	0.3 to 0.8	1.5
GRM31M			1.15 ±0.1		
GRM31C	3.2 ±0.2	1.6 ±0.2	1.6 ±0.2		

Part Number	Dimensions (mm)				
	L	W	T	e	g min.
GRM329			0.85 ±0.15/-0.05		
GRM32A			1.0 ±0/-0.2		
GRM32M			1.15 ±0.1		
GRM32N	3.2 ±0.3	2.5 ±0.2	1.35 ±0.15	0.3 min.	1.0
GRM32C			1.6 ±0.2		
GRM32R			1.8 ±0.2		
GRM32D			2.0 ±0.2		
GRM32E			2.5 ±0.2		

* Bulk Case: 1.6 ±0.07(L) × 0.8 ±0.07(W) × 0.8 ±0.07(T)
* The figure indicates typical Specification.

● Temperature Compensating Type C0G(5C) Characteristics

LxW [mm]		0.4x0.2(02)<01005>	0.6x0.3(03)<0201>	1.0x0.5(15)<0402>
Rated Volt. [Vdc]		16(1C)	50(1H)	50(1H)
Capacitance	Tolerance	Part Number		
0.1pF(R10)	±0.05pF(W)		GRM0335C1HR10WD01D	GRM1555C1HR10WA01D
	±0.1pF(B)		GRM0335C1HR10BD01D	GRM1555C1HR10BA01D
0.2pF(R20)	±0.05pF(W)	GRM0225C1CR20WD05L	GRM0335C1HR20WD01D	GRM1555C1HR20WA01D
	±0.1pF(B)	GRM0225C1CR20BD05L	GRM0335C1HR20BD01D	GRM1555C1HR20BA01D
0.3pF(R30)	±0.05pF(W)	GRM0225C1CR30WD05L	GRM0335C1HR30WD01D	GRM1555C1HR30WA01D
	±0.1pF(B)	GRM0225C1CR30BD05L	GRM0335C1HR30BD01D	GRM1555C1HR30BA01D
0.4pF(R40)	±0.05pF(W)	GRM0225C1CR40WD05L	GRM0335C1HR40WD01D	GRM1555C1HR40WA01D
	±0.1pF(B)	GRM0225C1CR40BD05L	GRM0335C1HR40BD01D	GRM1555C1HR40BA01D
0.5pF(R50)	±0.05pF(W)	GRM0225C1CR50WD05L	GRM0335C1HR50WD01D	GRM1555C1HR50WA01D
	±0.1pF(B)	GRM0225C1CR50BD05L	GRM0335C1HR50BD01D	GRM1555C1HR50BA01D
0.6pF(R60)	±0.05pF(W)	GRM0225C1CR60WD05L	GRM0335C1HR60WD01D	GRM1555C1HR60WA01D
	±0.1pF(B)	GRM0225C1CR60BD05L	GRM0335C1HR60BD01D	GRM1555C1HR60BA01D
0.7pF(R70)	±0.05pF(W)	GRM0225C1CR70WD05L	GRM0335C1HR70WD01D	GRM1555C1HR70WA01D
	±0.1pF(B)	GRM0225C1CR70BD05L	GRM0335C1HR70BD01D	GRM1555C1HR70BA01D
0.8pF(R80)	±0.05pF(W)	GRM0225C1CR80WD05L	GRM0335C1HR80WD01D	GRM1555C1HR80WA01D
	±0.1pF(B)	GRM0225C1CR80BD05L	GRM0335C1HR80BD01D	GRM1555C1HR80BA01D
0.9pF(R90)	±0.05pF(W)	GRM0225C1CR90WD05L	GRM0335C1HR90WD01D	GRM1555C1HR90WA01D
	±0.1pF(B)	GRM0225C1CR90BD05L	GRM0335C1HR90BD01D	GRM1555C1HR90BA01D
1.0pF(1R0)	±0.05pF(W)	GRM0225C1C1R0WD05L	GRM0335C1H1R0WD01D	GRM1555C1H1R0WA01D
	±0.1pF(B)	GRM0225C1C1R0BD05L	GRM0335C1H1R0BD01D	GRM1555C1H1R0BA01D
	±0.25pF(C)	GRM0225C1C1R0CD05L	GRM0335C1H1R0CD01D	GRM1555C1H1R0CA01D
1.1pF(1R1)	±0.05pF(W)	GRM0225C1C1R1WD05L	GRM0335C1H1R1WD01D	GRM1555C1H1R1WA01D
	±0.1pF(B)	GRM0225C1C1R1BD05L	GRM0335C1H1R1BD01D	GRM1555C1H1R1BA01D
	±0.25pF(C)	GRM0225C1C1R1CD05L	GRM0335C1H1R1CD01D	GRM1555C1H1R1CA01D
1.2pF(1R2)	±0.05pF(W)	GRM0225C1C1R2WD05L	GRM0335C1H1R2WD01D	GRM1555C1H1R2WA01D
	±0.1pF(B)	GRM0225C1C1R2BD05L	GRM0335C1H1R2BD01D	GRM1555C1H1R2BA01D
	±0.25pF(C)	GRM0225C1C1R2CD05L	GRM0335C1H1R2CD01D	GRM1555C1H1R2CA01D
1.3pF(1R3)	±0.05pF(W)	GRM0225C1C1R3WD05L	GRM0335C1H1R3WD01D	GRM1555C1H1R3WA01D
	±0.1pF(B)	GRM0225C1C1R3BD05L	GRM0335C1H1R3BD01D	GRM1555C1H1R3BA01D
	±0.25pF(C)	GRM0225C1C1R3CD05L	GRM0335C1H1R3CD01D	GRM1555C1H1R3CA01D
1.4pF(1R4)	±0.05pF(W)	GRM0225C1C1R4WD05L	GRM0335C1H1R4WD01D	GRM1555C1H1R4WA01D
	±0.1pF(B)	GRM0225C1C1R4BD05L	GRM0335C1H1R4BD01D	GRM1555C1H1R4BA01D
	±0.25pF(C)	GRM0225C1C1R4CD05L	GRM0335C1H1R4CD01D	GRM1555C1H1R4CA01D
1.5pF(1R5)	±0.05pF(W)	GRM0225C1C1R5WD05L	GRM0335C1H1R5WD01D	GRM1555C1H1R5WA01D
	±0.1pF(B)	GRM0225C1C1R5BD05L	GRM0335C1H1R5BD01D	GRM1555C1H1R5BA01D
	±0.25pF(C)	GRM0225C1C1R5CD05L	GRM0335C1H1R5CD01D	GRM1555C1H1R5CA01D

The part number code is shown in () and Unit is shown in []. < >: EIA [inch] Code

△Note • This PDF catalog is downloaded from the website of Murata Manufacturing co., Ltd. Therefore, it's specifications are subject to change or our products in it may be discontinued without advance notice. Please check with our sales representatives or product engineers before ordering.
• This PDF catalog has only typical specifications because there is no space for detailed specifications. Therefore, please approve our product specifications or transact the approval sheet for product specifications before ordering.

● Temperature Compensating Type C0G(5C) Characteristics

LxW [mm]		0.4x0.2(02)<01005>	0.6x0.3(03)<0201>	1.0x0.5(15)<0402>
Rated Volt. [Vdc]		16(1C)	50(1H)	50(1H)
Capacitance	Tolerance	Part Number		
1.6pF(1R6)	±0.05pF(W)	GRM0225C1C1R6WD05L	GRM0335C1H1R6WD01D	GRM1555C1H1R6WA01D
	±0.1pF(B)	GRM0225C1C1R6BD05L	GRM0335C1H1R6BD01D	GRM1555C1H1R6BA01D
	±0.25pF(C)	GRM0225C1C1R6CD05L	GRM0335C1H1R6CD01D	GRM1555C1H1R6CA01D
1.7pF(1R7)	±0.05pF(W)	GRM0225C1C1R7WD05L	GRM0335C1H1R7WD01D	GRM1555C1H1R7WA01D
	±0.1pF(B)	GRM0225C1C1R7BD05L	GRM0335C1H1R7BD01D	GRM1555C1H1R7BA01D
	±0.25pF(C)	GRM0225C1C1R7CD05L	GRM0335C1H1R7CD01D	GRM1555C1H1R7CA01D
1.8pF(1R8)	±0.05pF(W)	GRM0225C1C1R8WD05L	GRM0335C1H1R8WD01D	GRM1555C1H1R8WA01D
	±0.1pF(B)	GRM0225C1C1R8BD05L	GRM0335C1H1R8BD01D	GRM1555C1H1R8BA01D
	±0.25pF(C)	GRM0225C1C1R8CD05L	GRM0335C1H1R8CD01D	GRM1555C1H1R8CA01D
1.9pF(1R9)	±0.05pF(W)	GRM0225C1C1R9WD05L	GRM0335C1H1R9WD01D	GRM1555C1H1R9WA01D
	±0.1pF(B)	GRM0225C1C1R9BD05L	GRM0335C1H1R9BD01D	GRM1555C1H1R9BA01D
	±0.25pF(C)	GRM0225C1C1R9CD05L	GRM0335C1H1R9CD01D	GRM1555C1H1R9CA01D
2.0pF(2R0)	±0.05pF(W)	GRM0225C1C2R0WD05L	GRM0335C1H2R0WD01D	GRM1555C1H2R0WA01D
	±0.1pF(B)	GRM0225C1C2R0BD05L	GRM0335C1H2R0BD01D	GRM1555C1H2R0BA01D
	±0.25pF(C)	GRM0225C1C2R0CD05L	GRM0335C1H2R0CD01D	GRM1555C1H2R0CA01D
2.1pF(2R1)	±0.05pF(W)	GRM0225C1C2R1WD05L	GRM0335C1H2R1WD01D	GRM1555C1H2R1WA01D
	±0.1pF(B)	GRM0225C1C2R1BD05L	GRM0335C1H2R1BD01D	GRM1555C1H2R1BA01D
	±0.25pF(C)	GRM0225C1C2R1CD05L	GRM0335C1H2R1CD01D	GRM1555C1H2R1CA01D
2.2pF(2R2)	±0.05pF(W)	GRM0225C1C2R2WD05L	GRM0335C1H2R2WD01D	GRM1555C1H2R2WA01D
	±0.1pF(B)	GRM0225C1C2R2BD05L	GRM0335C1H2R2BD01D	GRM1555C1H2R2BA01D
	±0.25pF(C)	GRM0225C1C2R2CD05L	GRM0335C1H2R2CD01D	GRM1555C1H2R2CA01D
2.3pF(2R3)	±0.05pF(W)	GRM0225C1C2R3WD05L	GRM0335C1H2R3WD01D	GRM1555C1H2R3WA01D
	±0.1pF(B)	GRM0225C1C2R3BD05L	GRM0335C1H2R3BD01D	GRM1555C1H2R3BA01D
	±0.25pF(C)	GRM0225C1C2R3CD05L	GRM0335C1H2R3CD01D	GRM1555C1H2R3CA01D
2.4pF(2R4)	±0.05pF(W)	GRM0225C1C2R4WD05L	GRM0335C1H2R4WD01D	GRM1555C1H2R4WA01D
	±0.1pF(B)	GRM0225C1C2R4BD05L	GRM0335C1H2R4BD01D	GRM1555C1H2R4BA01D
	±0.25pF(C)	GRM0225C1C2R4CD05L	GRM0335C1H2R4CD01D	GRM1555C1H2R4CA01D
2.5pF(2R5)	±0.05pF(W)	GRM0225C1C2R5WD05L	GRM0335C1H2R5WD01D	GRM1555C1H2R5WA01D
	±0.1pF(B)	GRM0225C1C2R5BD05L	GRM0335C1H2R5BD01D	GRM1555C1H2R5BA01D
	±0.25pF(C)	GRM0225C1C2R5CD05L	GRM0335C1H2R5CD01D	GRM1555C1H2R5CA01D
2.6pF(2R6)	±0.05pF(W)	GRM0225C1C2R6WD05L	GRM0335C1H2R6WD01D	GRM1555C1H2R6WA01D
	±0.1pF(B)	GRM0225C1C2R6BD05L	GRM0335C1H2R6BD01D	GRM1555C1H2R6BA01D
	±0.25pF(C)	GRM0225C1C2R6CD05L	GRM0335C1H2R6CD01D	GRM1555C1H2R6CA01D
2.7pF(2R7)	±0.05pF(W)	GRM0225C1C2R7WD05L	GRM0335C1H2R7WD01D	GRM1555C1H2R7WA01D
	±0.1pF(B)	GRM0225C1C2R7BD05L	GRM0335C1H2R7BD01D	GRM1555C1H2R7BA01D
	±0.25pF(C)	GRM0225C1C2R7CD05L	GRM0335C1H2R7CD01D	GRM1555C1H2R7CA01D
2.8pF(2R8)	±0.05pF(W)	GRM0225C1C2R8WD05L	GRM0335C1H2R8WD01D	GRM1555C1H2R8WA01D
	±0.1pF(B)	GRM0225C1C2R8BD05L	GRM0335C1H2R8BD01D	GRM1555C1H2R8BA01D
	±0.25pF(C)	GRM0225C1C2R8CD05L	GRM0335C1H2R8CD01D	GRM1555C1H2R8CA01D
2.9pF(2R9)	±0.05pF(W)	GRM0225C1C2R9WD05L	GRM0335C1H2R9WD01D	GRM1555C1H2R9WA01D
	±0.1pF(B)	GRM0225C1C2R9BD05L	GRM0335C1H2R9BD01D	GRM1555C1H2R9BA01D
	±0.25pF(C)	GRM0225C1C2R9CD05L	GRM0335C1H2R9CD01D	GRM1555C1H2R9CA01D
3.0pF(3R0)	±0.05pF(W)	GRM0225C1C3R0WD05L	GRM0335C1H3R0WD01D	GRM1555C1H3R0WA01D
	±0.1pF(B)	GRM0225C1C3R0BD05L	GRM0335C1H3R0BD01D	GRM1555C1H3R0BA01D
	±0.25pF(C)	GRM0225C1C3R0CD05L	GRM0335C1H3R0CD01D	GRM1555C1H3R0CA01D
3.1pF(3R1)	±0.05pF(W)	GRM0225C1C3R1WD05L	GRM0335C1H3R1WD01D	GRM1555C1H3R1WA01D
	±0.1pF(B)	GRM0225C1C3R1BD05L	GRM0335C1H3R1BD01D	GRM1555C1H3R1BA01D
	±0.25pF(C)	GRM0225C1C3R1CD05L	GRM0335C1H3R1CD01D	GRM1555C1H3R1CA01D
3.2pF(3R2)	±0.05pF(W)	GRM0225C1C3R2WD05L	GRM0335C1H3R2WD01D	GRM1555C1H3R2WA01D
	±0.1pF(B)	GRM0225C1C3R2BD05L	GRM0335C1H3R2BD01D	GRM1555C1H3R2BA01D
	±0.25pF(C)	GRM0225C1C3R2CD05L	GRM0335C1H3R2CD01D	GRM1555C1H3R2CA01D

The part number code is shown in () and Unit is shown in []. < >: EIA [inch] Code

● Temperature Compensating Type C0G(5C) Characteristics

LxW [mm]		0.4x0.2(02)<01005>	0.6x0.3(03)<0201>	1.0x0.5(15)<0402>
Rated Volt. [Vdc]		16(1C)	50(1H)	50(1H)
Capacitance	Tolerance	Part Number		
3.3pF(3R3)	±0.05pF(W)	GRM0225C1C3R3WD05L	GRM0335C1H3R3WD01D	GRM1555C1H3R3WA01D
	±0.1pF(B)	GRM0225C1C3R3BD05L	GRM0335C1H3R3BD01D	GRM1555C1H3R3BA01D
	±0.25pF(C)	GRM0225C1C3R3CD05L	GRM0335C1H3R3CD01D	GRM1555C1H3R3CA01D
3.4pF(3R4)	±0.05pF(W)	GRM0225C1C3R4WD05L	GRM0335C1H3R4WD01D	GRM1555C1H3R4WA01D
	±0.1pF(B)	GRM0225C1C3R4BD05L	GRM0335C1H3R4BD01D	GRM1555C1H3R4BA01D
	±0.25pF(C)	GRM0225C1C3R4CD05L	GRM0335C1H3R4CD01D	GRM1555C1H3R4CA01D
3.5pF(3R5)	±0.05pF(W)	GRM0225C1C3R5WD05L	GRM0335C1H3R5WD01D	GRM1555C1H3R5WA01D
	±0.1pF(B)	GRM0225C1C3R5BD05L	GRM0335C1H3R5BD01D	GRM1555C1H3R5BA01D
	±0.25pF(C)	GRM0225C1C3R5CD05L	GRM0335C1H3R5CD01D	GRM1555C1H3R5CA01D
3.6pF(3R6)	±0.05pF(W)	GRM0225C1C3R6WD05L	GRM0335C1H3R6WD01D	GRM1555C1H3R6WA01D
	±0.1pF(B)	GRM0225C1C3R6BD05L	GRM0335C1H3R6BD01D	GRM1555C1H3R6BA01D
	±0.25pF(C)	GRM0225C1C3R6CD05L	GRM0335C1H3R6CD01D	GRM1555C1H3R6CA01D
3.7pF(3R7)	±0.05pF(W)	GRM0225C1C3R7WD05L	GRM0335C1H3R7WD01D	GRM1555C1H3R7WA01D
	±0.1pF(B)	GRM0225C1C3R7BD05L	GRM0335C1H3R7BD01D	GRM1555C1H3R7BA01D
	±0.25pF(C)	GRM0225C1C3R7CD05L	GRM0335C1H3R7CD01D	GRM1555C1H3R7CA01D
3.8pF(3R8)	±0.05pF(W)	GRM0225C1C3R8WD05L	GRM0335C1H3R8WD01D	GRM1555C1H3R8WA01D
	±0.1pF(B)	GRM0225C1C3R8BD05L	GRM0335C1H3R8BD01D	GRM1555C1H3R8BA01D
	±0.25pF(C)	GRM0225C1C3R8CD05L	GRM0335C1H3R8CD01D	GRM1555C1H3R8CA01D
3.9pF(3R9)	±0.05pF(W)	GRM0225C1C3R9WD05L	GRM0335C1H3R9WD01D	GRM1555C1H3R9WA01D
	±0.1pF(B)	GRM0225C1C3R9BD05L	GRM0335C1H3R9BD01D	GRM1555C1H3R9BA01D
	±0.25pF(C)	GRM0225C1C3R9CD05L	GRM0335C1H3R9CD01D	GRM1555C1H3R9CA01D
4.0pF(4R0)	±0.05pF(W)	GRM0225C1C4R0WD05L	GRM0335C1H4R0WD01D	GRM1555C1H4R0WA01D
	±0.1pF(B)	GRM0225C1C4R0BD05L	GRM0335C1H4R0BD01D	GRM1555C1H4R0BA01D
	±0.25pF(C)	GRM0225C1C4R0CD05L	GRM0335C1H4R0CD01D	GRM1555C1H4R0CA01D
4.1pF(4R1)	±0.05pF(W)	GRM0225C1C4R1WD05L	GRM0335C1H4R1WD01D	GRM1555C1H4R1WA01D
	±0.1pF(B)	GRM0225C1C4R1BD05L	GRM0335C1H4R1BD01D	GRM1555C1H4R1BA01D
	±0.25pF(C)	GRM0225C1C4R1CD05L	GRM0335C1H4R1CD01D	GRM1555C1H4R1CA01D
4.2pF(4R2)	±0.05pF(W)	GRM0225C1C4R2WD05L	GRM0335C1H4R2WD01D	GRM1555C1H4R2WA01D
	±0.1pF(B)	GRM0225C1C4R2BD05L	GRM0335C1H4R2BD01D	GRM1555C1H4R2BA01D
	±0.25pF(C)	GRM0225C1C4R2CD05L	GRM0335C1H4R2CD01D	GRM1555C1H4R2CA01D
4.3pF(4R3)	±0.05pF(W)	GRM0225C1C4R3WD05L	GRM0335C1H4R3WD01D	GRM1555C1H4R3WA01D
	±0.1pF(B)	GRM0225C1C4R3BD05L	GRM0335C1H4R3BD01D	GRM1555C1H4R3BA01D
	±0.25pF(C)	GRM0225C1C4R3CD05L	GRM0335C1H4R3CD01D	GRM1555C1H4R3CA01D
4.4pF(4R4)	±0.05pF(W)	GRM0225C1C4R4WD05L	GRM0335C1H4R4WD01D	GRM1555C1H4R4WA01D
	±0.1pF(B)	GRM0225C1C4R4BD05L	GRM0335C1H4R4BD01D	GRM1555C1H4R4BA01D
	±0.25pF(C)	GRM0225C1C4R4CD05L	GRM0335C1H4R4CD01D	GRM1555C1H4R4CA01D
4.5pF(4R5)	±0.05pF(W)	GRM0225C1C4R5WD05L	GRM0335C1H4R5WD01D	GRM1555C1H4R5WA01D
	±0.1pF(B)	GRM0225C1C4R5BD05L	GRM0335C1H4R5BD01D	GRM1555C1H4R5BA01D
	±0.25pF(C)	GRM0225C1C4R5CD05L	GRM0335C1H4R5CD01D	GRM1555C1H4R5CA01D
4.6pF(4R6)	±0.05pF(W)	GRM0225C1C4R6WD05L	GRM0335C1H4R6WD01D	GRM1555C1H4R6WA01D
	±0.1pF(B)	GRM0225C1C4R6BD05L	GRM0335C1H4R6BD01D	GRM1555C1H4R6BA01D
	±0.25pF(C)	GRM0225C1C4R6CD05L	GRM0335C1H4R6CD01D	GRM1555C1H4R6CA01D
4.7pF(4R7)	±0.05pF(W)	GRM0225C1C4R7WD05L	GRM0335C1H4R7WD01D	GRM1555C1H4R7WA01D
	±0.1pF(B)	GRM0225C1C4R7BD05L	GRM0335C1H4R7BD01D	GRM1555C1H4R7BA01D
	±0.25pF(C)	GRM0225C1C4R7CD05L	GRM0335C1H4R7CD01D	GRM1555C1H4R7CA01D
4.8pF(4R8)	±0.05pF(W)	GRM0225C1C4R8WD05L	GRM0335C1H4R8WD01D	GRM1555C1H4R8WA01D
	±0.1pF(B)	GRM0225C1C4R8BD05L	GRM0335C1H4R8BD01D	GRM1555C1H4R8BA01D
	±0.25pF(C)	GRM0225C1C4R8CD05L	GRM0335C1H4R8CD01D	GRM1555C1H4R8CA01D
4.9pF(4R9)	±0.05pF(W)	GRM0225C1C4R9WD05L	GRM0335C1H4R9WD01D	GRM1555C1H4R9WA01D
	±0.1pF(B)	GRM0225C1C4R9BD05L	GRM0335C1H4R9BD01D	GRM1555C1H4R9BA01D
	±0.25pF(C)	GRM0225C1C4R9CD05L	GRM0335C1H4R9CD01D	GRM1555C1H4R9CA01D

The part number code is shown in () and Unit is shown in []. < >: EIA [inch] Code

△Note • This PDF catalog is downloaded from the website of Murata Manufacturing co., Ltd. Therefore, it's specifications are subject to change or our products in it may be discontinued without advance notice. Please check with our sales representatives or product engineers before ordering.
• This PDF catalog has only typical specifications because there is no space for detailed specifications. Therefore, please approve our product specifications or transact the approval sheet for product specifications before ordering.

● Temperature Compensating Type C0G(5C) Characteristics

LxW [mm]		0.4x0.2(02)<01005>	0.6x0.3(03)<0201>	1.0x0.5(15)<0402>
Rated Volt. [Vdc]		16(1C)	50(1H)	50(1H)
Capacitance	Tolerance	Part Number		
5.0pF(5R0)	±0.05pF(W)	GRM0225C1C5R0WD05L	GRM0335C1H5R0WD01D	GRM1555C1H5R0WA01D
	±0.1pF(B)	GRM0225C1C5R0BD05L	GRM0335C1H5R0BD01D	GRM1555C1H5R0BA01D
	±0.25pF(C)	GRM0225C1C5R0CD05L	GRM0335C1H5R0CD01D	GRM1555C1H5R0CA01D
5.1pF(5R1)	±0.05pF(W)	GRM0225C1C5R1WD05L	GRM0335C1H5R1WD01D	GRM1555C1H5R1WA01D
	±0.1pF(B)	GRM0225C1C5R1BD05L	GRM0335C1H5R1BD01D	GRM1555C1H5R1BA01D
	±0.25pF(C)	GRM0225C1C5R1CD05L	GRM0335C1H5R1CD01D	GRM1555C1H5R1CA01D
	±0.5pF(D)	GRM0225C1C5R1DD05L	GRM0335C1H5R1DD01D	GRM1555C1H5R1DA01D
5.2pF(5R2)	±0.05pF(W)	GRM0225C1C5R2WD05L	GRM0335C1H5R2WD01D	GRM1555C1H5R2WA01D
	±0.1pF(B)	GRM0225C1C5R2BD05L	GRM0335C1H5R2BD01D	GRM1555C1H5R2BA01D
	±0.25pF(C)	GRM0225C1C5R2CD05L	GRM0335C1H5R2CD01D	GRM1555C1H5R2CA01D
	±0.5pF(D)	GRM0225C1C5R2DD05L	GRM0335C1H5R2DD01D	GRM1555C1H5R2DA01D
5.3pF(5R3)	±0.05pF(W)	GRM0225C1C5R3WD05L	GRM0335C1H5R3WD01D	GRM1555C1H5R3WA01D
	±0.1pF(B)	GRM0225C1C5R3BD05L	GRM0335C1H5R3BD01D	GRM1555C1H5R3BA01D
	±0.25pF(C)	GRM0225C1C5R3CD05L	GRM0335C1H5R3CD01D	GRM1555C1H5R3CA01D
	±0.5pF(D)	GRM0225C1C5R3DD05L	GRM0335C1H5R3DD01D	GRM1555C1H5R3DA01D
5.4pF(5R4)	±0.05pF(W)	GRM0225C1C5R4WD05L	GRM0335C1H5R4WD01D	GRM1555C1H5R4WA01D
	±0.1pF(B)	GRM0225C1C5R4BD05L	GRM0335C1H5R4BD01D	GRM1555C1H5R4BA01D
	±0.25pF(C)	GRM0225C1C5R4CD05L	GRM0335C1H5R4CD01D	GRM1555C1H5R4CA01D
	±0.5pF(D)	GRM0225C1C5R4DD05L	GRM0335C1H5R4DD01D	GRM1555C1H5R4DA01D
5.5pF(5R5)	±0.05pF(W)	GRM0225C1C5R5WD05L	GRM0335C1H5R5WD01D	GRM1555C1H5R5WA01D
	±0.1pF(B)	GRM0225C1C5R5BD05L	GRM0335C1H5R5BD01D	GRM1555C1H5R5BA01D
	±0.25pF(C)	GRM0225C1C5R5CD05L	GRM0335C1H5R5CD01D	GRM1555C1H5R5CA01D
	±0.5pF(D)	GRM0225C1C5R5DD05L	GRM0335C1H5R5DD01D	GRM1555C1H5R5DA01D
5.6pF(5R6)	±0.05pF(W)	GRM0225C1C5R6WD05L	GRM0335C1H5R6WD01D	GRM1555C1H5R6WA01D
	±0.1pF(B)	GRM0225C1C5R6BD05L	GRM0335C1H5R6BD01D	GRM1555C1H5R6BA01D
	±0.25pF(C)	GRM0225C1C5R6CD05L	GRM0335C1H5R6CD01D	GRM1555C1H5R6CA01D
	±0.5pF(D)	GRM0225C1C5R6DD05L	GRM0335C1H5R6DD01D	GRM1555C1H5R6DA01D
5.7pF(5R7)	±0.05pF(W)	GRM0225C1C5R7WD05L	GRM0335C1H5R7WD01D	GRM1555C1H5R7WA01D
	±0.1pF(B)	GRM0225C1C5R7BD05L	GRM0335C1H5R7BD01D	GRM1555C1H5R7BA01D
	±0.25pF(C)	GRM0225C1C5R7CD05L	GRM0335C1H5R7CD01D	GRM1555C1H5R7CA01D
	±0.5pF(D)	GRM0225C1C5R7DD05L	GRM0335C1H5R7DD01D	GRM1555C1H5R7DA01D
5.8pF(5R8)	±0.05pF(W)	GRM0225C1C5R8WD05L	GRM0335C1H5R8WD01D	GRM1555C1H5R8WA01D
	±0.1pF(B)	GRM0225C1C5R8BD05L	GRM0335C1H5R8BD01D	GRM1555C1H5R8BA01D
	±0.25pF(C)	GRM0225C1C5R8CD05L	GRM0335C1H5R8CD01D	GRM1555C1H5R8CA01D
	±0.5pF(D)	GRM0225C1C5R8DD05L	GRM0335C1H5R8DD01D	GRM1555C1H5R8DA01D
5.9pF(5R9)	±0.05pF(W)	GRM0225C1C5R9WD05L	GRM0335C1H5R9WD01D	GRM1555C1H5R9WA01D
	±0.1pF(B)	GRM0225C1C5R9BD05L	GRM0335C1H5R9BD01D	GRM1555C1H5R9BA01D
	±0.25pF(C)	GRM0225C1C5R9CD05L	GRM0335C1H5R9CD01D	GRM1555C1H5R9CA01D
	±0.5pF(D)	GRM0225C1C5R9DD05L	GRM0335C1H5R9DD01D	GRM1555C1H5R9DA01D
6.0pF(6R0)	±0.05pF(W)	GRM0225C1C6R0WD05L	GRM0335C1H6R0WD01D	GRM1555C1H6R0WA01D
	±0.1pF(B)	GRM0225C1C6R0BD05L	GRM0335C1H6R0BD01D	GRM1555C1H6R0BA01D
	±0.25pF(C)	GRM0225C1C6R0CD05L	GRM0335C1H6R0CD01D	GRM1555C1H6R0CA01D
	±0.5pF(D)	GRM0225C1C6R0DD05L	GRM0335C1H6R0DD01D	GRM1555C1H6R0DA01D
6.1pF(6R1)	±0.05pF(W)	GRM0225C1C6R1WD05L	GRM0335C1H6R1WD01D	GRM1555C1H6R1WA01D
	±0.1pF(B)	GRM0225C1C6R1BD05L	GRM0335C1H6R1BD01D	GRM1555C1H6R1BA01D
	±0.25pF(C)	GRM0225C1C6R1CD05L	GRM0335C1H6R1CD01D	GRM1555C1H6R1CA01D
	±0.5pF(D)	GRM0225C1C6R1DD05L	GRM0335C1H6R1DD01D	GRM1555C1H6R1DA01D
6.2pF(6R2)	±0.05pF(W)	GRM0225C1C6R2WD05L	GRM0335C1H6R2WD01D	GRM1555C1H6R2WA01D
	±0.1pF(B)	GRM0225C1C6R2BD05L	GRM0335C1H6R2BD01D	GRM1555C1H6R2BA01D
	±0.25pF(C)	GRM0225C1C6R2CD05L	GRM0335C1H6R2CD01D	GRM1555C1H6R2CA01D
	±0.5pF(D)	GRM0225C1C6R2DD05L	GRM0335C1H6R2DD01D	GRM1555C1H6R2DA01D

The part number code is shown in () and Unit is shown in []. < >: EIA [inch] Code

● Temperature Compensating Type C0G(5C) Characteristics

LxW [mm]		0.4x0.2(02)<01005>	0.6x0.3(03)<0201>	1.0x0.5(15)<0402>
Rated Volt. [Vdc]		16(1C)	50(1H)	50(1H)
Capacitance	Tolerance	Part Number		
6.3pF(6R3)	±0.05pF(W)	GRM0225C1C6R3WD05L	GRM0335C1H6R3WD01D	GRM1555C1H6R3WA01D
	±0.1pF(B)	GRM0225C1C6R3BD05L	GRM0335C1H6R3BD01D	GRM1555C1H6R3BA01D
	±0.25pF(C)	GRM0225C1C6R3CD05L	GRM0335C1H6R3CD01D	GRM1555C1H6R3CA01D
	±0.5pF(D)	GRM0225C1C6R3DD05L	GRM0335C1H6R3DD01D	GRM1555C1H6R3DA01D
6.4pF(6R4)	±0.05pF(W)	GRM0225C1C6R4WD05L	GRM0335C1H6R4WD01D	GRM1555C1H6R4WA01D
	±0.1pF(B)	GRM0225C1C6R4BD05L	GRM0335C1H6R4BD01D	GRM1555C1H6R4BA01D
	±0.25pF(C)	GRM0225C1C6R4CD05L	GRM0335C1H6R4CD01D	GRM1555C1H6R4CA01D
	±0.5pF(D)	GRM0225C1C6R4DD05L	GRM0335C1H6R4DD01D	GRM1555C1H6R4DA01D
6.5pF(6R5)	±0.05pF(W)	GRM0225C1C6R5WD05L	GRM0335C1H6R5WD01D	GRM1555C1H6R5WA01D
	±0.1pF(B)	GRM0225C1C6R5BD05L	GRM0335C1H6R5BD01D	GRM1555C1H6R5BA01D
	±0.25pF(C)	GRM0225C1C6R5CD05L	GRM0335C1H6R5CD01D	GRM1555C1H6R5CA01D
	±0.5pF(D)	GRM0225C1C6R5DD05L	GRM0335C1H6R5DD01D	GRM1555C1H6R5DA01D
6.6pF(6R6)	±0.05pF(W)	GRM0225C1C6R6WD05L	GRM0335C1H6R6WD01D	GRM1555C1H6R6WA01D
	±0.1pF(B)	GRM0225C1C6R6BD05L	GRM0335C1H6R6BD01D	GRM1555C1H6R6BA01D
	±0.25pF(C)	GRM0225C1C6R6CD05L	GRM0335C1H6R6CD01D	GRM1555C1H6R6CA01D
	±0.5pF(D)	GRM0225C1C6R6DD05L	GRM0335C1H6R6DD01D	GRM1555C1H6R6DA01D
6.7pF(6R7)	±0.05pF(W)	GRM0225C1C6R7WD05L	GRM0335C1H6R7WD01D	GRM1555C1H6R7WA01D
	±0.1pF(B)	GRM0225C1C6R7BD05L	GRM0335C1H6R7BD01D	GRM1555C1H6R7BA01D
	±0.25pF(C)	GRM0225C1C6R7CD05L	GRM0335C1H6R7CD01D	GRM1555C1H6R7CA01D
	±0.5pF(D)	GRM0225C1C6R7DD05L	GRM0335C1H6R7DD01D	GRM1555C1H6R7DA01D
6.8pF(6R8)	±0.05pF(W)	GRM0225C1C6R8WD05L	GRM0335C1H6R8WD01D	GRM1555C1H6R8WA01D
	±0.1pF(B)	GRM0225C1C6R8BD05L	GRM0335C1H6R8BD01D	GRM1555C1H6R8BA01D
	±0.25pF(C)	GRM0225C1C6R8CD05L	GRM0335C1H6R8CD01D	GRM1555C1H6R8CA01D
	±0.5pF(D)	GRM0225C1C6R8DD05L	GRM0335C1H6R8DD01D	GRM1555C1H6R8DA01D
6.9pF(6R9)	±0.05pF(W)	GRM0225C1C6R9WD05L	GRM0335C1H6R9WD01D	GRM1555C1H6R9WA01D
	±0.1pF(B)	GRM0225C1C6R9BD05L	GRM0335C1H6R9BD01D	GRM1555C1H6R9BA01D
	±0.25pF(C)	GRM0225C1C6R9CD05L	GRM0335C1H6R9CD01D	GRM1555C1H6R9CA01D
	±0.5pF(D)	GRM0225C1C6R9DD05L	GRM0335C1H6R9DD01D	GRM1555C1H6R9DA01D
7.0pF(7R0)	±0.05pF(W)	GRM0225C1C7R0WD05L	GRM0335C1H7R0WD01D	GRM1555C1H7R0WA01D
	±0.1pF(B)	GRM0225C1C7R0BD05L	GRM0335C1H7R0BD01D	GRM1555C1H7R0BA01D
	±0.25pF(C)	GRM0225C1C7R0CD05L	GRM0335C1H7R0CD01D	GRM1555C1H7R0CA01D
	±0.5pF(D)	GRM0225C1C7R0DD05L	GRM0335C1H7R0DD01D	GRM1555C1H7R0DA01D
7.1pF(7R1)	±0.05pF(W)	GRM0225C1C7R1WD05L	GRM0335C1H7R1WD01D	GRM1555C1H7R1WA01D
	±0.1pF(B)	GRM0225C1C7R1BD05L	GRM0335C1H7R1BD01D	GRM1555C1H7R1BA01D
	±0.25pF(C)	GRM0225C1C7R1CD05L	GRM0335C1H7R1CD01D	GRM1555C1H7R1CA01D
	±0.5pF(D)	GRM0225C1C7R1DD05L	GRM0335C1H7R1DD01D	GRM1555C1H7R1DA01D
7.2pF(7R2)	±0.05pF(W)	GRM0225C1C7R2WD05L	GRM0335C1H7R2WD01D	GRM1555C1H7R2WA01D
	±0.1pF(B)	GRM0225C1C7R2BD05L	GRM0335C1H7R2BD01D	GRM1555C1H7R2BA01D
	±0.25pF(C)	GRM0225C1C7R2CD05L	GRM0335C1H7R2CD01D	GRM1555C1H7R2CA01D
	±0.5pF(D)	GRM0225C1C7R2DD05L	GRM0335C1H7R2DD01D	GRM1555C1H7R2DA01D
7.3pF(7R3)	±0.05pF(W)	GRM0225C1C7R3WD05L	GRM0335C1H7R3WD01D	GRM1555C1H7R3WA01D
	±0.1pF(B)	GRM0225C1C7R3BD05L	GRM0335C1H7R3BD01D	GRM1555C1H7R3BA01D
	±0.25pF(C)	GRM0225C1C7R3CD05L	GRM0335C1H7R3CD01D	GRM1555C1H7R3CA01D
	±0.5pF(D)	GRM0225C1C7R3DD05L	GRM0335C1H7R3DD01D	GRM1555C1H7R3DA01D
7.4pF(7R4)	±0.05pF(W)	GRM0225C1C7R4WD05L	GRM0335C1H7R4WD01D	GRM1555C1H7R4WA01D
	±0.1pF(B)	GRM0225C1C7R4BD05L	GRM0335C1H7R4BD01D	GRM1555C1H7R4BA01D
	±0.25pF(C)	GRM0225C1C7R4CD05L	GRM0335C1H7R4CD01D	GRM1555C1H7R4CA01D
	±0.5pF(D)	GRM0225C1C7R4DD05L	GRM0335C1H7R4DD01D	GRM1555C1H7R4DA01D
7.5pF(7R5)	±0.05pF(W)	GRM0225C1C7R5WD05L	GRM0335C1H7R5WD01D	GRM1555C1H7R5WA01D
	±0.1pF(B)	GRM0225C1C7R5BD05L	GRM0335C1H7R5BD01D	GRM1555C1H7R5BA01D
	±0.25pF(C)	GRM0225C1C7R5CD05L	GRM0335C1H7R5CD01D	GRM1555C1H7R5CA01D
	±0.5pF(D)	GRM0225C1C7R5DD05L	GRM0335C1H7R5DD01D	GRM1555C1H7R5DA01D

The part number code is shown in () and Unit is shown in []. <>: EIA [inch] Code

△Note • This PDF catalog is downloaded from the website of Murata Manufacturing co., ltd. Therefore, it's specifications are subject to change or our products in it may be discontinued without advance notice. Please check with our sales representatives or product engineers before ordering.
• This PDF catalog has only typical specifications because there is no space for detailed specifications. Therefore, please approve our product specifications or transact the approval sheet for product specifications before ordering.

● Temperature Compensating Type C0G(5C) Characteristics

LxW [mm]		0.4x0.2(02)<01005>	0.6x0.3(03)<0201>	1.0x0.5(15)<0402>
Rated Volt. [Vdc]		16(1C)	50(1H)	50(1H)
Capacitance	Tolerance	Part Number		
7.6pF(7R6)	±0.05pF(W)	GRM0225C1C7R6WD05L	GRM0335C1H7R6WD01D	GRM1555C1H7R6WA01D
	±0.1pF(B)	GRM0225C1C7R6BD05L	GRM0335C1H7R6BD01D	GRM1555C1H7R6BA01D
	±0.25pF(C)	GRM0225C1C7R6CD05L	GRM0335C1H7R6CD01D	GRM1555C1H7R6CA01D
	±0.5pF(D)	GRM0225C1C7R6DD05L	GRM0335C1H7R6DD01D	GRM1555C1H7R6DA01D
7.7pF(7R7)	±0.05pF(W)	GRM0225C1C7R7WD05L	GRM0335C1H7R7WD01D	GRM1555C1H7R7WA01D
	±0.1pF(B)	GRM0225C1C7R7BD05L	GRM0335C1H7R7BD01D	GRM1555C1H7R7BA01D
	±0.25pF(C)	GRM0225C1C7R7CD05L	GRM0335C1H7R7CD01D	GRM1555C1H7R7CA01D
	±0.5pF(D)	GRM0225C1C7R7DD05L	GRM0335C1H7R7DD01D	GRM1555C1H7R7DA01D
7.8pF(7R8)	±0.05pF(W)	GRM0225C1C7R8WD05L	GRM0335C1H7R8WD01D	GRM1555C1H7R8WA01D
	±0.1pF(B)	GRM0225C1C7R8BD05L	GRM0335C1H7R8BD01D	GRM1555C1H7R8BA01D
	±0.25pF(C)	GRM0225C1C7R8CD05L	GRM0335C1H7R8CD01D	GRM1555C1H7R8CA01D
	±0.5pF(D)	GRM0225C1C7R8DD05L	GRM0335C1H7R8DD01D	GRM1555C1H7R8DA01D
7.9pF(7R9)	±0.05pF(W)	GRM0225C1C7R9WD05L	GRM0335C1H7R9WD01D	GRM1555C1H7R9WA01D
	±0.1pF(B)	GRM0225C1C7R9BD05L	GRM0335C1H7R9BD01D	GRM1555C1H7R9BA01D
	±0.25pF(C)	GRM0225C1C7R9CD05L	GRM0335C1H7R9CD01D	GRM1555C1H7R9CA01D
	±0.5pF(D)	GRM0225C1C7R9DD05L	GRM0335C1H7R9DD01D	GRM1555C1H7R9DA01D
8.0pF(8R0)	±0.05pF(W)	GRM0225C1C8R0WD05L	GRM0335C1H8R0WD01D	GRM1555C1H8R0WA01D
	±0.1pF(B)	GRM0225C1C8R0BD05L	GRM0335C1H8R0BD01D	GRM1555C1H8R0BA01D
	±0.25pF(C)	GRM0225C1C8R0CD05L	GRM0335C1H8R0CD01D	GRM1555C1H8R0CA01D
	±0.5pF(D)	GRM0225C1C8R0DD05L	GRM0335C1H8R0DD01D	GRM1555C1H8R0DA01D
8.1pF(8R1)	±0.05pF(W)	GRM0225C1C8R1WD05L	GRM0335C1H8R1WD01D	GRM1555C1H8R1WA01D
	±0.1pF(B)	GRM0225C1C8R1BD05L	GRM0335C1H8R1BD01D	GRM1555C1H8R1BA01D
	±0.25pF(C)	GRM0225C1C8R1CD05L	GRM0335C1H8R1CD01D	GRM1555C1H8R1CA01D
	±0.5pF(D)	GRM0225C1C8R1DD05L	GRM0335C1H8R1DD01D	GRM1555C1H8R1DA01D
8.2pF(8R2)	±0.05pF(W)	GRM0225C1C8R2WD05L	GRM0335C1H8R2WD01D	GRM1555C1H8R2WA01D
	±0.1pF(B)	GRM0225C1C8R2BD05L	GRM0335C1H8R2BD01D	GRM1555C1H8R2BA01D
	±0.25pF(C)	GRM0225C1C8R2CD05L	GRM0335C1H8R2CD01D	GRM1555C1H8R2CA01D
	±0.5pF(D)	GRM0225C1C8R2DD05L	GRM0335C1H8R2DD01D	GRM1555C1H8R2DA01D
8.3pF(8R3)	±0.05pF(W)	GRM0225C1C8R3WD05L	GRM0335C1H8R3WD01D	GRM1555C1H8R3WA01D
	±0.1pF(B)	GRM0225C1C8R3BD05L	GRM0335C1H8R3BD01D	GRM1555C1H8R3BA01D
	±0.25pF(C)	GRM0225C1C8R3CD05L	GRM0335C1H8R3CD01D	GRM1555C1H8R3CA01D
	±0.5pF(D)	GRM0225C1C8R3DD05L	GRM0335C1H8R3DD01D	GRM1555C1H8R3DA01D
8.4pF(8R4)	±0.05pF(W)	GRM0225C1C8R4WD05L	GRM0335C1H8R4WD01D	GRM1555C1H8R4WA01D
	±0.1pF(B)	GRM0225C1C8R4BD05L	GRM0335C1H8R4BD01D	GRM1555C1H8R4BA01D
	±0.25pF(C)	GRM0225C1C8R4CD05L	GRM0335C1H8R4CD01D	GRM1555C1H8R4CA01D
	±0.5pF(D)	GRM0225C1C8R4DD05L	GRM0335C1H8R4DD01D	GRM1555C1H8R4DA01D
8.5pF(8R5)	±0.05pF(W)	GRM0225C1C8R5WD05L	GRM0335C1H8R5WD01D	GRM1555C1H8R5WA01D
	±0.1pF(B)	GRM0225C1C8R5BD05L	GRM0335C1H8R5BD01D	GRM1555C1H8R5BA01D
	±0.25pF(C)	GRM0225C1C8R5CD05L	GRM0335C1H8R5CD01D	GRM1555C1H8R5CA01D
	±0.5pF(D)	GRM0225C1C8R5DD05L	GRM0335C1H8R5DD01D	GRM1555C1H8R5DA01D
8.6pF(8R6)	±0.05pF(W)	GRM0225C1C8R6WD05L	GRM0335C1H8R6WD01D	GRM1555C1H8R6WA01D
	±0.1pF(B)	GRM0225C1C8R6BD05L	GRM0335C1H8R6BD01D	GRM1555C1H8R6BA01D
	±0.25pF(C)	GRM0225C1C8R6CD05L	GRM0335C1H8R6CD01D	GRM1555C1H8R6CA01D
	±0.5pF(D)	GRM0225C1C8R6DD05L	GRM0335C1H8R6DD01D	GRM1555C1H8R6DA01D
8.7pF(8R7)	±0.05pF(W)	GRM0225C1C8R7WD05L	GRM0335C1H8R7WD01D	GRM1555C1H8R7WA01D
	±0.1pF(B)	GRM0225C1C8R7BD05L	GRM0335C1H8R7BD01D	GRM1555C1H8R7BA01D
	±0.25pF(C)	GRM0225C1C8R7CD05L	GRM0335C1H8R7CD01D	GRM1555C1H8R7CA01D
	±0.5pF(D)	GRM0225C1C8R7DD05L	GRM0335C1H8R7DD01D	GRM1555C1H8R7DA01D
8.8pF(8R8)	±0.05pF(W)	GRM0225C1C8R8WD05L	GRM0335C1H8R8WD01D	GRM1555C1H8R8WA01D
	±0.1pF(B)	GRM0225C1C8R8BD05L	GRM0335C1H8R8BD01D	GRM1555C1H8R8BA01D
	±0.25pF(C)	GRM0225C1C8R8CD05L	GRM0335C1H8R8CD01D	GRM1555C1H8R8CA01D
	±0.5pF(D)	GRM0225C1C8R8DD05L	GRM0335C1H8R8DD01D	GRM1555C1H8R8DA01D

The part number code is shown in () and Unit is shown in []. < >: EIA [inch] Code

● Temperature Compensating Type C0G(5C) Characteristics

LxW [mm]		0.4x0.2(02)<01005>	0.6x0.3(03)<0201>	1.0x0.5(15)<0402>
Rated Volt. [Vdc]		16(1C)	50(1H)	50(1H)
Capacitance	Tolerance	Part Number		
8.9pF(8R9)	±0.05pF(W)	GRM0225C1C8R9WD05L	GRM0335C1H8R9WD01D	GRM1555C1H8R9WA01D
	±0.1pF(B)	GRM0225C1C8R9BD05L	GRM0335C1H8R9BD01D	GRM1555C1H8R9BA01D
	±0.25pF(C)	GRM0225C1C8R9CD05L	GRM0335C1H8R9CD01D	GRM1555C1H8R9CA01D
	±0.5pF(D)	GRM0225C1C8R9DD05L	GRM0335C1H8R9DD01D	GRM1555C1H8R9DA01D
9.0pF(9R0)	±0.05pF(W)	GRM0225C1C9R0WD05L	GRM0335C1H9R0WD01D	GRM1555C1H9R0WA01D
	±0.1pF(B)	GRM0225C1C9R0BD05L	GRM0335C1H9R0BD01D	GRM1555C1H9R0BA01D
	±0.25pF(C)	GRM0225C1C9R0CD05L	GRM0335C1H9R0CD01D	GRM1555C1H9R0CA01D
	±0.5pF(D)	GRM0225C1C9R0DD05L	GRM0335C1H9R0DD01D	GRM1555C1H9R0DA01D
9.1pF(9R1)	±0.05pF(W)	GRM0225C1C9R1WD05L	GRM0335C1H9R1WD01D	GRM1555C1H9R1WA01D
	±0.1pF(B)	GRM0225C1C9R1BD05L	GRM0335C1H9R1BD01D	GRM1555C1H9R1BA01D
	±0.25pF(C)	GRM0225C1C9R1CD05L	GRM0335C1H9R1CD01D	GRM1555C1H9R1CA01D
	±0.5pF(D)	GRM0225C1C9R1DD05L	GRM0335C1H9R1DD01D	GRM1555C1H9R1DA01D
9.2pF(9R2)	±0.05pF(W)	GRM0225C1C9R2WD05L	GRM0335C1H9R2WD01D	GRM1555C1H9R2WA01D
	±0.1pF(B)	GRM0225C1C9R2BD05L	GRM0335C1H9R2BD01D	GRM1555C1H9R2BA01D
	±0.25pF(C)	GRM0225C1C9R2CD05L	GRM0335C1H9R2CD01D	GRM1555C1H9R2CA01D
	±0.5pF(D)	GRM0225C1C9R2DD05L	GRM0335C1H9R2DD01D	GRM1555C1H9R2DA01D
9.3pF(9R3)	±0.05pF(W)	GRM0225C1C9R3WD05L	GRM0335C1H9R3WD01D	GRM1555C1H9R3WA01D
	±0.1pF(B)	GRM0225C1C9R3BD05L	GRM0335C1H9R3BD01D	GRM1555C1H9R3BA01D
	±0.25pF(C)	GRM0225C1C9R3CD05L	GRM0335C1H9R3CD01D	GRM1555C1H9R3CA01D
	±0.5pF(D)	GRM0225C1C9R3DD05L	GRM0335C1H9R3DD01D	GRM1555C1H9R3DA01D
9.4pF(9R4)	±0.05pF(W)	GRM0225C1C9R4WD05L	GRM0335C1H9R4WD01D	GRM1555C1H9R4WA01D
	±0.1pF(B)	GRM0225C1C9R4BD05L	GRM0335C1H9R4BD01D	GRM1555C1H9R4BA01D
	±0.25pF(C)	GRM0225C1C9R4CD05L	GRM0335C1H9R4CD01D	GRM1555C1H9R4CA01D
	±0.5pF(D)	GRM0225C1C9R4DD05L	GRM0335C1H9R4DD01D	GRM1555C1H9R4DA01D
9.5pF(9R5)	±0.05pF(W)	GRM0225C1C9R5WD05L	GRM0335C1H9R5WD01D	GRM1555C1H9R5WA01D
	±0.1pF(B)	GRM0225C1C9R5BD05L	GRM0335C1H9R5BD01D	GRM1555C1H9R5BA01D
	±0.25pF(C)	GRM0225C1C9R5CD05L	GRM0335C1H9R5CD01D	GRM1555C1H9R5CA01D
	±0.5pF(D)	GRM0225C1C9R5DD05L	GRM0335C1H9R5DD01D	GRM1555C1H9R5DA01D
9.6pF(9R6)	±0.05pF(W)	GRM0225C1C9R6WD05L	GRM0335C1H9R6WD01D	GRM1555C1H9R6WA01D
	±0.1pF(B)	GRM0225C1C9R6BD05L	GRM0335C1H9R6BD01D	GRM1555C1H9R6BA01D
	±0.25pF(C)	GRM0225C1C9R6CD05L	GRM0335C1H9R6CD01D	GRM1555C1H9R6CA01D
	±0.5pF(D)	GRM0225C1C9R6DD05L	GRM0335C1H9R6DD01D	GRM1555C1H9R6DA01D
9.7pF(9R7)	±0.05pF(W)	GRM0225C1C9R7WD05L	GRM0335C1H9R7WD01D	GRM1555C1H9R7WA01D
	±0.1pF(B)	GRM0225C1C9R7BD05L	GRM0335C1H9R7BD01D	GRM1555C1H9R7BA01D
	±0.25pF(C)	GRM0225C1C9R7CD05L	GRM0335C1H9R7CD01D	GRM1555C1H9R7CA01D
	±0.5pF(D)	GRM0225C1C9R7DD05L	GRM0335C1H9R7DD01D	GRM1555C1H9R7DA01D
9.8pF(9R8)	±0.05pF(W)	GRM0225C1C9R8WD05L	GRM0335C1H9R8WD01D	GRM1555C1H9R8WA01D
	±0.1pF(B)	GRM0225C1C9R8BD05L	GRM0335C1H9R8BD01D	GRM1555C1H9R8BA01D
	±0.25pF(C)	GRM0225C1C9R8CD05L	GRM0335C1H9R8CD01D	GRM1555C1H9R8CA01D
	±0.5pF(D)	GRM0225C1C9R8DD05L	GRM0335C1H9R8DD01D	GRM1555C1H9R8DA01D
9.9pF(9R9)	±0.05pF(W)	GRM0225C1C9R9WD05L	GRM0335C1H9R9WD01D	GRM1555C1H9R9WA01D
	±0.1pF(B)	GRM0225C1C9R9BD05L	GRM0335C1H9R9BD01D	GRM1555C1H9R9BA01D
	±0.25pF(C)	GRM0225C1C9R9CD05L	GRM0335C1H9R9CD01D	GRM1555C1H9R9CA01D
	±0.5pF(D)	GRM0225C1C9R9DD05L	GRM0335C1H9R9DD01D	GRM1555C1H9R9DA01D

The part number code is shown in () and Unit is shown in []. < >: EIA [inch] Code

△Note • This PDF catalog is downloaded from the website of Murata Manufacturing co., Ltd. Therefore, it's specifications are subject to change or our products in it may be discontinued without advance notice. Please check with our sales representatives or product engineers before ordering.
• This PDF catalog has only typical specifications because there is no space for detailed specifications. Therefore, please approve our product specifications or transact the approval sheet for product specifications before ordering.

● Temperature Compensating Type C0G(5C) Characteristics

LxW [mm]		0.4x0.2(02)<01005>			0.6x0.3(03)<0201>
Rated Volt. [Vdc]		16(1C)	10(1A)	6.3(0J)	50(1H)
Capacitance	Tolerance	Part Number			
10pF(100)	±2%(G)	GRM0225C1C100GD05L			GRM0335C1H100GD01D
	±5%(J)	GRM0225C1C100JD05L			GRM0335C1H100JD01D
12pF(120)	±2%(G)	GRM0225C1C120GD05L			GRM0335C1H120GD01D
	±5%(J)	GRM0225C1C120JD05L			GRM0335C1H120JD01D
15pF(150)	±2%(G)	GRM0225C1C150GD05L			GRM0335C1H150GD01D
	±5%(J)	GRM0225C1C150JD05L			GRM0335C1H150JD01D
18pF(180)	±2%(G)	GRM0225C1C180GD05L			GRM0335C1H180GD01D
	±5%(J)	GRM0225C1C180JD05L			GRM0335C1H180JD01D
22pF(220)	±2%(G)	GRM0225C1C220GD05L			GRM0335C1H220GD01D
	±5%(J)	GRM0225C1C220JD05L			GRM0335C1H220JD01D
27pF(270)	±2%(G)	GRM0225C1C270GD05L			GRM0335C1H270GD01D
	±5%(J)	GRM0225C1C270JD05L			GRM0335C1H270JD01D
33pF(330)	±2%(G)	GRM0225C1C330GD05L			GRM0335C1H330GD01D
	±5%(J)	GRM0225C1C330JD05L			GRM0335C1H330JD01D
39pF(390)	±2%(G)	GRM0225C1C390GD05L			GRM0335C1H390GD01D
	±5%(J)	GRM0225C1C390JD05L			GRM0335C1H390JD01D
47pF(470)	±2%(G)	GRM0225C1C470GD05L			GRM0335C1H470GD01D
	±5%(J)	GRM0225C1C470JD05L			GRM0335C1H470JD01D
56pF(560)	±2%(G)		GRM0225C1A560GD05L	GRM0225C0J560GD05L	GRM0335C1H560GD01D
	±5%(J)		GRM0225C1A560JD05L	GRM0225C0J560JD05L	GRM0335C1H560JD01D
68pF(680)	±2%(G)		GRM0225C1A680GD05L	GRM0225C0J680GD05L	GRM0335C1H680GD01D
	±5%(J)		GRM0225C1A680JD05L	GRM0225C0J680JD05L	GRM0335C1H680JD01D
82pF(820)	±2%(G)		GRM0225C1A820GD05L	GRM0225C0J820GD05L	GRM0335C1H820GD01D
	±5%(J)		GRM0225C1A820JD05L	GRM0225C0J820JD05L	GRM0335C1H820JD01D
100pF(101)	±2%(G)		GRM0225C1A101GD05L	GRM0225C0J101GD05L	GRM0335C1H101GD01D
	±5%(J)		GRM0225C1A101JD05L	GRM0225C0J101JD05L	GRM0335C1H101JD01D

The part number code is shown in () and Unit is shown in []. < >: EIA [inch] Code

● Temperature Compensating Type C0G(5C) Characteristics

LxW [mm]		1.0x0.5(15)<0402>
Rated Volt. [Vdc]		50(1H)
TC		C0G(5C)
Capacitance	Tolerance	Part Number
10pF(100)	±2%(G)	GRM1555C1H100GA01D
	±5%(J)	GRM1555C1H100JA01D
12pF(120)	±2%(G)	GRM1555C1H120GA01D
	±5%(J)	GRM1555C1H120JA01D
15pF(150)	±2%(G)	GRM1555C1H150GA01D
	±5%(J)	GRM1555C1H150JA01D
18pF(180)	±2%(G)	GRM1555C1H180GA01D
	±5%(J)	GRM1555C1H180JA01D
22pF(220)	±2%(G)	GRM1555C1H220GA01D
	±5%(J)	GRM1555C1H220JA01D
27pF(270)	±2%(G)	GRM1555C1H270GA01D
	±5%(J)	GRM1555C1H270JA01D
33pF(330)	±2%(G)	GRM1555C1H330GA01D
	±5%(J)	GRM1555C1H330JA01D
39pF(390)	±2%(G)	GRM1555C1H390GA01D
	±5%(J)	GRM1555C1H390JA01D
47pF(470)	±2%(G)	GRM1555C1H470GA01D
	±5%(J)	GRM1555C1H470JA01D
56pF(560)	±2%(G)	GRM1555C1H560GA01D
	±5%(J)	GRM1555C1H560JA01D
68pF(680)	±2%(G)	GRM1555C1H680GA01D
	±5%(J)	GRM1555C1H680JA01D
82pF(820)	±2%(G)	GRM1555C1H820GA01D
	±5%(J)	GRM1555C1H820JA01D
100pF(101)	±2%(G)	GRM1555C1H101GA01D
	±5%(J)	GRM1555C1H101JA01D
120pF(121)	±2%(G)	GRM1555C1H121GA01D
	±5%(J)	GRM1555C1H121JA01D
150pF(151)	±2%(G)	GRM1555C1H151GA01D
	±5%(J)	GRM1555C1H151JA01D
180pF(181)	±2%(G)	GRM1555C1H181GA01D
	±5%(J)	GRM1555C1H181JA01D
220pF(221)	±2%(G)	GRM1555C1H221GA01D
	±5%(J)	GRM1555C1H221JA01D
270pF(271)	±2%(G)	GRM1555C1H271GA01D
	±5%(J)	GRM1555C1H271JA01D
330pF(331)	±2%(G)	GRM1555C1H331GA01D
	±5%(J)	GRM1555C1H331JA01D
390pF(391)	±2%(G)	GRM1555C1H391GA01D
	±5%(J)	GRM1555C1H391JA01D
470pF(471)	±2%(G)	GRM1555C1H471GA01D
	±5%(J)	GRM1555C1H471JA01D
560pF(561)	±2%(G)	GRM1555C1H561GA01D
	±5%(J)	GRM1555C1H561JA01D
680pF(681)	±2%(G)	GRM1555C1H681GA01D
	±5%(J)	GRM1555C1H681JA01D
820pF(821)	±2%(G)	GRM1555C1H821GA01D
	±5%(J)	GRM1555C1H821JA01D
1000pF(102)	±2%(G)	GRM1555C1H102GA01D
	±5%(J)	GRM1555C1H102JA01D

The part number code is shown in () and Unit is shown in []. < >: EIA [inch] Code

△Note • This PDF catalog is downloaded from the website of Murata Manufacturing co., Ltd. Therefore, it's specifications are subject to change or our products in it may be discontinued without advance notice. Please check with our sales representatives or product engineers before ordering.
• This PDF catalog has only typical specifications because there is no space for detailed specifications. Therefore, please approve our product specifications or transact the approval sheet for product specifications before ordering.

● Temperature Compensating Type C0G(5C) Characteristics

LxW [mm]		1.6x0.8(18)<0603>	
Rated Volt. [Vdc]		100(2A)	50(1H)
Capacitance	Tolerance	Part Number	
10pF(100)	±5%(J)	GRM1885C2A100JA01D	GRM1885C1H100JA01D
12pF(120)	±5%(J)	GRM1885C2A120JA01D	GRM1885C1H120JA01D
15pF(150)	±5%(J)	GRM1885C2A150JA01D	GRM1885C1H150JA01D
18pF(180)	±5%(J)	GRM1885C2A180JA01D	GRM1885C1H180JA01D
22pF(220)	±5%(J)	GRM1885C2A220JA01D	GRM1885C1H220JA01D
27pF(270)	±5%(J)	GRM1885C2A270JA01D	GRM1885C1H270JA01D
33pF(330)	±5%(J)	GRM1885C2A330JA01D	GRM1885C1H330JA01D
39pF(390)	±5%(J)	GRM1885C2A390JA01D	GRM1885C1H390JA01D
47pF(470)	±5%(J)	GRM1885C2A470JA01D	GRM1885C1H470JA01D
56pF(560)	±5%(J)	GRM1885C2A560JA01D	GRM1885C1H560JA01D
68pF(680)	±5%(J)	GRM1885C2A680JA01D	GRM1885C1H680JA01D
82pF(820)	±5%(J)	GRM1885C2A820JA01D	GRM1885C1H820JA01D
100pF(101)	±5%(J)	GRM1885C2A101JA01D	GRM1885C1H101JA01D
120pF(121)	±5%(J)	GRM1885C2A121JA01D	GRM1885C1H121JA01D
150pF(151)	±5%(J)	GRM1885C2A151JA01D	GRM1885C1H151JA01D
180pF(181)	±5%(J)	GRM1885C2A181JA01D	GRM1885C1H181JA01D
220pF(221)	±5%(J)	GRM1885C2A221JA01D	GRM1885C1H221JA01D
270pF(271)	±5%(J)	GRM1885C2A271JA01D	GRM1885C1H271JA01D
330pF(331)	±5%(J)	GRM1885C2A331JA01D	GRM1885C1H331JA01D
390pF(391)	±5%(J)	GRM1885C2A391JA01D	GRM1885C1H391JA01D
470pF(471)	±5%(J)	GRM1885C2A471JA01D	GRM1885C1H471JA01D
560pF(561)	±5%(J)	GRM1885C2A561JA01D	GRM1885C1H561JA01D
680pF(681)	±5%(J)	GRM1885C2A681JA01D	GRM1885C1H681JA01D
820pF(821)	±5%(J)	GRM1885C2A821JA01D	GRM1885C1H821JA01D
1000pF(102)	±5%(J)	GRM1885C2A102JA01D	GRM1885C1H102JA01D
1200pF(122)	±5%(J)	GRM1885C2A122JA01D	GRM1885C1H122JA01D
1500pF(152)	±5%(J)	GRM1885C2A152JA01D	GRM1885C1H152JA01D
1800pF(182)	±5%(J)		GRM1885C1H182JA01D
2200pF(222)	±5%(J)		GRM1885C1H222JA01D
2700pF(272)	±5%(J)		GRM1885C1H272JA01D
3300pF(332)	±5%(J)		GRM1885C1H332JA01D
3900pF(392)	±5%(J)		GRM1885C1H392JA01D

The part number code is shown in () and Unit is shown in []. < >: EIA [inch] Code

● Temperature Compensating Type C0G(5C) Characteristics

LxW [mm]		2.0x1.25(21)<0805>		3.2x1.6(31)<1206>	
Rated Volt. [Vdc]		100(2A)	50(1H)	100(2A)	50(1H)
Capacitance	Tolerance	Part Number			
100pF(101)	±5%(J)	GRM2165C2A101JA01D			
120pF(121)	±5%(J)	GRM2165C2A121JA01D			
150pF(151)	±5%(J)	GRM2165C2A151JA01D			
180pF(181)	±5%(J)	GRM2165C2A181JA01D			
220pF(221)	±5%(J)	GRM2165C2A221JA01D			
270pF(271)	±5%(J)	GRM2165C2A271JA01D			
330pF(331)	±5%(J)	GRM2165C2A331JA01D			
390pF(391)	±5%(J)	GRM2165C2A391JA01D			
470pF(471)	±5%(J)	GRM2165C2A471JA01D			
560pF(561)	±5%(J)	GRM2165C2A561JA01D			
680pF(681)	±5%(J)	GRM2165C2A681JA01D			
820pF(821)	±5%(J)	GRM2165C2A821JA01D			
1000pF(102)	±5%(J)	GRM2165C2A102JA01D			
1200pF(122)	±5%(J)	GRM2165C2A122JA01D	GRM2165C1H122JA01D		
1500pF(152)	±5%(J)	GRM2165C2A152JA01D	GRM2165C1H152JA01D		
1800pF(182)	±5%(J)	GRM2165C2A182JA01D	GRM2165C1H182JA01D	GRM3195C2A182JA01D	
2200pF(222)	±5%(J)	GRM2165C2A222JA01D	GRM2165C1H222JA01D	GRM3195C2A222JA01D	
2700pF(272)	±5%(J)	GRM2165C2A272JA01D	GRM2165C1H272JA01D	GRM3195C2A272JA01D	
3300pF(332)	±5%(J)	GRM2165C2A332JA01D	GRM2165C1H332JA01D	GRM3195C2A332JA01D	
3900pF(392)	±5%(J)		GRM2165C1H392JA01D	GRM3195C2A392JA01D	
4700pF(472)	±5%(J)		GRM2165C1H472JA01D	GRM3195C2A472JA01D	GRM3195C1H472JA01D
5600pF(562)	±5%(J)		GRM2195C1H562JA01D	GRM3195C2A562JA01D	GRM3195C1H562JA01D
6800pF(682)	±5%(J)		GRM2195C1H682JA01D	GRM3195C2A682JA01D	GRM3195C1H682JA01D
8200pF(822)	±5%(J)		GRM2195C1H822JA01D	GRM3195C2A822JA01D	GRM3195C1H822JA01D
10000pF(103)	±5%(J)		GRM2195C1H103JA01D	GRM3195C2A103JA01D	GRM3195C1H103JA01D
12000pF(123)	±5%(J)		GRM2195C1H123JA01D		GRM3195C1H123JA01D
15000pF(153)	±5%(J)		GRM2195C1H153JA01D		GRM3195C1H153JA01D
18000pF(183)	±5%(J)		GRM21B5C1H183JA01L		GRM3195C1H183JA01D
22000pF(223)	±5%(J)		GRM21B5C1H223JA01L		GRM3195C1H223JA01D
27000pF(273)	±5%(J)				GRM3195C1H273JA01D
33000pF(333)	±5%(J)				GRM3195C1H333JA01D
39000pF(393)	±5%(J)				GRM3195C1H393JA01D
47000pF(473)	±5%(J)				GRM31M5C1H473JA01L
56000pF(563)	±5%(J)				GRM31M5C1H563JA01L
68000pF(683)	±5%(J)				GRM31C5C1H683JA01L
82000pF(823)	±5%(J)				GRM31C5C1H823JA01L
100000pF(104)	±5%(J)				GRM31C5C1H104JA01L

The part number code is shown in () and Unit is shown in []. < >: EIA [inch] Code

△Note • This PDF catalog is downloaded from the website of Murata Manufacturing co., ltd. Therefore, it's specifications are subject to change or our products in it may be discontinued without advance notice. Please check with our sales representatives or product engineers before ordering.
• This PDF catalog has only typical specifications because there is no space for detailed specifications. Therefore, please approve our product specifications or transact the approval sheet for product specifications before ordering.

● Temperature Compensating Type C0G(5C) Characteristics Low Profile

1
Capacitors

LxW [mm]		1.0x0.5(15)<0402>
Rated Volt. [Vdc]		50(1H)
Capacitance	Tolerance	Part Number
0.1pF(R10)	±0.1pF(B)	GRM1535C1HR10BDD5D
0.2pF(R20)	±0.1pF(B)	GRM1535C1HR20BDD5D
0.3pF(R30)	±0.1pF(B)	GRM1535C1HR30BDD5D
0.4pF(R40)	±0.1pF(B)	GRM1535C1HR40BDD5D
0.5pF(R50)	±0.1pF(B)	GRM1535C1HR50BDD5D
0.6pF(R60)	±0.1pF(B)	GRM1535C1HR60BDD5D
0.7pF(R70)	±0.1pF(B)	GRM1535C1HR70BDD5D
0.8pF(R80)	±0.1pF(B)	GRM1535C1HR80BDD5D
0.9pF(R90)	±0.1pF(B)	GRM1535C1HR90BDD5D
1.0pF(1R0)	±0.25pF(C)	GRM1535C1H1R0CDD5D
1.1pF(1R1)	±0.25pF(C)	GRM1535C1H1R1CDD5D
1.2pF(1R2)	±0.25pF(C)	GRM1535C1H1R2CDD5D
1.3pF(1R3)	±0.25pF(C)	GRM1535C1H1R3CDD5D
1.4pF(1R4)	±0.25pF(C)	GRM1535C1H1R4CDD5D
1.5pF(1R5)	±0.25pF(C)	GRM1535C1H1R5CDD5D
1.6pF(1R6)	±0.25pF(C)	GRM1535C1H1R6CDD5D
1.7pF(1R7)	±0.25pF(C)	GRM1535C1H1R7CDD5D
1.8pF(1R8)	±0.25pF(C)	GRM1535C1H1R8CDD5D
1.9pF(1R9)	±0.25pF(C)	GRM1535C1H1R9CDD5D
2.0pF(2R0)	±0.25pF(C)	GRM1535C1H2R0CDD5D
2.1pF(2R1)	±0.25pF(C)	GRM1535C1H2R1CDD5D
2.2pF(2R2)	±0.25pF(C)	GRM1535C1H2R2CDD5D
2.3pF(2R3)	±0.25pF(C)	GRM1535C1H2R3CDD5D
2.4pF(2R4)	±0.25pF(C)	GRM1535C1H2R4CDD5D
2.5pF(2R5)	±0.25pF(C)	GRM1535C1H2R5CDD5D
2.6pF(2R6)	±0.25pF(C)	GRM1535C1H2R6CDD5D
2.7pF(2R7)	±0.25pF(C)	GRM1535C1H2R7CDD5D
2.8pF(2R8)	±0.25pF(C)	GRM1535C1H2R8CDD5D
2.9pF(2R9)	±0.25pF(C)	GRM1535C1H2R9CDD5D
3.0pF(3R0)	±0.25pF(C)	GRM1535C1H3R0CDD5D
3.1pF(3R1)	±0.25pF(C)	GRM1535C1H3R1CDD5D
3.2pF(3R2)	±0.25pF(C)	GRM1535C1H3R2CDD5D
3.3pF(3R3)	±0.25pF(C)	GRM1535C1H3R3CDD5D
3.4pF(3R4)	±0.25pF(C)	GRM1535C1H3R4CDD5D
3.5pF(3R5)	±0.25pF(C)	GRM1535C1H3R5CDD5D
3.6pF(3R6)	±0.25pF(C)	GRM1535C1H3R6CDD5D
3.7pF(3R7)	±0.25pF(C)	GRM1535C1H3R7CDD5D
3.8pF(3R8)	±0.25pF(C)	GRM1535C1H3R8CDD5D
3.9pF(3R9)	±0.25pF(C)	GRM1535C1H3R9CDD5D
4.0pF(4R0)	±0.25pF(C)	GRM1535C1H4R0CDD5D
4.1pF(4R1)	±0.25pF(C)	GRM1535C1H4R1CDD5D
4.2pF(4R2)	±0.25pF(C)	GRM1535C1H4R2CDD5D
4.3pF(4R3)	±0.25pF(C)	GRM1535C1H4R3CDD5D
4.4pF(4R4)	±0.25pF(C)	GRM1535C1H4R4CDD5D
4.5pF(4R5)	±0.25pF(C)	GRM1535C1H4R5CDD5D
4.6pF(4R6)	±0.25pF(C)	GRM1535C1H4R6CDD5D
4.7pF(4R7)	±0.25pF(C)	GRM1535C1H4R7CDD5D
4.8pF(4R8)	±0.25pF(C)	GRM1535C1H4R8CDD5D
4.9pF(4R9)	±0.25pF(C)	GRM1535C1H4R9CDD5D
5.0pF(5R0)	±0.25pF(C)	GRM1535C1H5R0CDD5D
5.1pF(5R1)	±0.5pF(D)	GRM1535C1H5R1DDD5D
5.2pF(5R2)	±0.5pF(D)	GRM1535C1H5R2DDD5D
5.3pF(5R3)	±0.5pF(D)	GRM1535C1H5R3DDD5D

LxW [mm]		1.0x0.5(15)<0402>
Rated Volt. [Vdc]		50(1H)
Capacitance	Tolerance	Part Number
5.4pF(5R4)	±0.5pF(D)	GRM1535C1H5R4DDD5D
5.5pF(5R5)	±0.5pF(D)	GRM1535C1H5R5DDD5D
5.6pF(5R6)	±0.5pF(D)	GRM1535C1H5R6DDD5D
5.7pF(5R7)	±0.5pF(D)	GRM1535C1H5R7DDD5D
5.8pF(5R8)	±0.5pF(D)	GRM1535C1H5R8DDD5D
5.9pF(5R9)	±0.5pF(D)	GRM1535C1H5R9DDD5D
6.0pF(6R0)	±0.5pF(D)	GRM1535C1H6R0DDD5D
6.1pF(6R1)	±0.5pF(D)	GRM1535C1H6R1DDD5D
6.2pF(6R2)	±0.5pF(D)	GRM1535C1H6R2DDD5D
6.3pF(6R3)	±0.5pF(D)	GRM1535C1H6R3DDD5D
6.4pF(6R4)	±0.5pF(D)	GRM1535C1H6R4DDD5D
6.5pF(6R5)	±0.5pF(D)	GRM1535C1H6R5DDD5D
6.6pF(6R6)	±0.5pF(D)	GRM1535C1H6R6DDD5D
6.7pF(6R7)	±0.5pF(D)	GRM1535C1H6R7DDD5D
6.8pF(6R8)	±0.5pF(D)	GRM1535C1H6R8DDD5D
6.9pF(6R9)	±0.5pF(D)	GRM1535C1H6R9DDD5D
7.0pF(7R0)	±0.5pF(D)	GRM1535C1H7R0DDD5D
7.1pF(7R1)	±0.5pF(D)	GRM1535C1H7R1DDD5D
7.2pF(7R2)	±0.5pF(D)	GRM1535C1H7R2DDD5D
7.3pF(7R3)	±0.5pF(D)	GRM1535C1H7R3DDD5D
7.4pF(7R4)	±0.5pF(D)	GRM1535C1H7R4DDD5D
7.5pF(7R5)	±0.5pF(D)	GRM1535C1H7R5DDD5D
7.6pF(7R6)	±0.5pF(D)	GRM1535C1H7R6DDD5D
7.7pF(7R7)	±0.5pF(D)	GRM1535C1H7R7DDD5D
7.8pF(7R8)	±0.5pF(D)	GRM1535C1H7R8DDD5D
7.9pF(7R9)	±0.5pF(D)	GRM1535C1H7R9DDD5D
8.0pF(8R0)	±0.5pF(D)	GRM1535C1H8R0DDD5D
8.1pF(8R1)	±0.5pF(D)	GRM1535C1H8R1DDD5D
8.2pF(8R2)	±0.5pF(D)	GRM1535C1H8R2DDD5D
8.3pF(8R3)	±0.5pF(D)	GRM1535C1H8R3DDD5D
8.4pF(8R4)	±0.5pF(D)	GRM1535C1H8R4DDD5D
8.5pF(8R5)	±0.5pF(D)	GRM1535C1H8R5DDD5D
8.6pF(8R6)	±0.5pF(D)	GRM1535C1H8R6DDD5D
8.7pF(8R7)	±0.5pF(D)	GRM1535C1H8R7DDD5D
8.8pF(8R8)	±0.5pF(D)	GRM1535C1H8R8DDD5D
8.9pF(8R9)	±0.5pF(D)	GRM1535C1H8R9DDD5D
9.0pF(9R0)	±0.5pF(D)	GRM1535C1H9R0DDD5D
9.1pF(9R1)	±0.5pF(D)	GRM1535C1H9R1DDD5D
9.2pF(9R2)	±0.5pF(D)	GRM1535C1H9R2DDD5D
9.3pF(9R3)	±0.5pF(D)	GRM1535C1H9R3DDD5D
9.4pF(9R4)	±0.5pF(D)	GRM1535C1H9R4DDD5D
9.5pF(9R5)	±0.5pF(D)	GRM1535C1H9R5DDD5D
9.6pF(9R6)	±0.5pF(D)	GRM1535C1H9R6DDD5D
9.7pF(9R7)	±0.5pF(D)	GRM1535C1H9R7DDD5D
9.8pF(9R8)	±0.5pF(D)	GRM1535C1H9R8DDD5D
9.9pF(9R9)	±0.5pF(D)	GRM1535C1H9R9DDD5D
10pF(100)	±5%(J)	GRM1535C1H100JDD5D
12pF(120)	±5%(J)	GRM1535C1H120JDD5D
15pF(150)	±5%(J)	GRM1535C1H150JDD5D
18pF(180)	±5%(J)	GRM1535C1H180JDD5D
22pF(220)	±5%(J)	GRM1535C1H220JDD5D
27pF(270)	±5%(J)	GRM1535C1H270JDD5D
33pF(330)	±5%(J)	GRM1535C1H330JDD5D

The part number code is shown in () and Unit is shown in []. < >: EIA [inch] Code

⚠ Note • This PDF catalog is downloaded from the website of Murata Manufacturing co., Ltd. Therefore, it's specifications are subject to change or our products in it may be discontinued without advance notice. Please check with our sales representatives or product engineers before ordering.
• This PDF catalog has only typical specifications because there is no space for detailed specifications. Therefore, please approve our product specifications or transact the approval sheet for product specifications before ordering.

● Temperature Compensating Type C0G(5C) Characteristics Low Profile

LxW [mm]		1.0x0.5(15)<0402>
Rated Volt. [Vdc]		50(1H)
Capacitance	Tolerance	Part Number
39pF(390)	±5%(J)	GRM1535C1H390JDD5D
47pF(470)	±5%(J)	GRM1535C1H470JDD5D
56pF(560)	±5%(J)	GRM1535C1H560JDD5D
68pF(680)	±5%(J)	GRM1535C1H680JDD5D
82pF(820)	±5%(J)	GRM1535C1H820JDD5D
100pF(101)	±5%(J)	GRM1535C1H101JDD5D
120pF(121)	±5%(J)	GRM1535C1H121JDD5D
150pF(151)	±5%(J)	GRM1535C1H151JDD5D
180pF(181)	±5%(J)	GRM1535C1H181JDD5D
220pF(221)	±5%(J)	GRM1535C1H221JDD5D
270pF(271)	±5%(J)	GRM1535C1H271JDD5D
330pF(331)	±5%(J)	GRM1535C1H331JDD5D
390pF(391)	±5%(J)	GRM1535C1H391JDD5D
470pF(471)	±5%(J)	GRM1535C1H471JDD5D
560pF(561)	±5%(J)	GRM1535C1H561JDD5D
680pF(681)	±5%(J)	GRM1535C1H681JDD5D

LxW [mm]		2.0x1.25(21)<0805>		3.2x1.6(31)<1206>	
Rated Volt. [Vdc]		100(2A)	50(1H)	100(2A)	50(1H)
Capacitance	Tolerance	Part Number			
100pF(101)	±5%(J)	GRM2165C2A101JA01D			
120pF(121)	±5%(J)	GRM2165C2A121JA01D			
150pF(151)	±5%(J)	GRM2165C2A151JA01D			
180pF(181)	±5%(J)	GRM2165C2A181JA01D			
220pF(221)	±5%(J)	GRM2165C2A221JA01D			
270pF(271)	±5%(J)	GRM2165C2A271JA01D			
330pF(331)	±5%(J)	GRM2165C2A331JA01D			
390pF(391)	±5%(J)	GRM2165C2A391JA01D			
470pF(471)	±5%(J)	GRM2165C2A471JA01D			
560pF(561)	±5%(J)	GRM2165C2A561JA01D			
680pF(681)	±5%(J)	GRM2165C2A681JA01D			
820pF(821)	±5%(J)	GRM2165C2A821JA01D			
1000pF(102)	±5%(J)	GRM2165C2A102JA01D			
1200pF(122)	±5%(J)	GRM2165C2A122JA01D	GRM2165C1H122JA01D		
1500pF(152)	±5%(J)	GRM2165C2A152JA01D	GRM2165C1H152JA01D		
1800pF(182)	±5%(J)	GRM2165C2A182JA01D	GRM2165C1H182JA01D	GRM3195C2A182JA01D	
2200pF(222)	±5%(J)	GRM2165C2A222JA01D	GRM2165C1H222JA01D	GRM3195C2A222JA01D	
2700pF(272)	±5%(J)	GRM2165C2A272JA01D	GRM2165C1H272JA01D	GRM3195C2A272JA01D	
3300pF(332)	±5%(J)	GRM2165C2A332JA01D	GRM2165C1H332JA01D	GRM3195C2A332JA01D	
3900pF(392)	±5%(J)		GRM2165C1H392JA01D	GRM3195C2A392JA01D	
4700pF(472)	±5%(J)		GRM2165C1H472JA01D	GRM3195C2A472JA01D	GRM3195C1H472JA01D
5600pF(562)	±5%(J)		GRM2195C1H562JA01D	GRM3195C2A562JA01D	GRM3195C1H562JA01D
6800pF(682)	±5%(J)		GRM2195C1H682JA01D	GRM3195C2A682JA01D	GRM3195C1H682JA01D
8200pF(822)	±5%(J)		GRM2195C1H822JA01D	GRM3195C2A822JA01D	GRM3195C1H822JA01D
10000pF(103)	±5%(J)		GRM2195C1H103JA01D	GRM3195C2A103JA01D	GRM3195C1H103JA01D
12000pF(123)	±5%(J)		GRM2195C1H123JA01D		GRM3195C1H123JA01D
15000pF(153)	±5%(J)		GRM2195C1H153JA01D		GRM3195C1H153JA01D
18000pF(183)	±5%(J)				GRM3195C1H183JA01D
22000pF(223)	±5%(J)				GRM3195C1H223JA01D
27000pF(273)	±5%(J)				GRM3195C1H273JA01D
33000pF(333)	±5%(J)				GRM3195C1H333JA01D
39000pF(393)	±5%(J)				GRM3195C1H393JA01D
47000pF(473)	±5%(J)				GRM31M5C1H473JA01L
56000pF(563)	±5%(J)				GRM31M5C1H563JA01L

The part number code is shown in () and Unit is shown in []. < >: EIA [inch] Code

△Note • This PDF catalog is downloaded from the website of Murata Manufacturing co., ltd. Therefore, it's specifications are subject to change or our products in it may be discontinued without advance notice. Please check with our sales representatives or product engineers before ordering.
 • This PDF catalog has only typical specifications because there is no space for detailed specifications. Therefore, please approve our product specifications or transact the approval sheet for product specifications before ordering.

● Temperature Compensating Type U2J(7U) Characteristics

LxW [mm]		0.6x0.3(03)<0201>		1.0x0.5(15)<0402>	
Rated Volt. [Vdc]		50(1H)	25(1E)	50(1H)	10(1A)
Capacitance	Tolerance	Part Number			
1.0pF(1R0)	±0.25pF(C)	GRM0337U1H1R0CD01D		GRM1557U1H1R0CZ01D	
2.0pF(2R0)	±0.25pF(C)	GRM0337U1H2R0CD01D		GRM1557U1H2R0CZ01D	
3.0pF(3R0)	±0.25pF(C)	GRM0337U1H3R0CD01D		GRM1557U1H3R0CZ01D	
4.0pF(4R0)	±0.25pF(C)	GRM0337U1H4R0CD01D		GRM1557U1H4R0CZ01D	
5.0pF(5R0)	±0.25pF(C)	GRM0337U1H5R0CD01D		GRM1557U1H5R0CZ01D	
6.0pF(6R0)	±0.5pF(D)	GRM0337U1H6R0DD01D		GRM1557U1H6R0DZ01D	
7.0pF(7R0)	±0.5pF(D)	GRM0337U1H7R0DD01D		GRM1557U1H7R0DZ01D	
8.0pF(8R0)	±0.5pF(D)	GRM0337U1H8R0DD01D		GRM1557U1H8R0DZ01D	
9.0pF(9R0)	±0.5pF(D)	GRM0337U1H9R0DD01D		GRM1557U1H9R0DZ01D	
10pF(100)	±5%(J)	GRM0337U1H100JD01D		GRM1557U1H100JZ01D	
12pF(120)	±5%(J)	GRM0337U1H120JD01D		GRM1557U1H120JZ01D	
15pF(150)	±5%(J)	GRM0337U1H150JD01D		GRM1557U1H150JZ01D	
18pF(180)	±5%(J)		GRM0337U1E180JD01D	GRM1557U1H180JZ01D	
22pF(220)	±5%(J)		GRM0337U1E220JD01D	GRM1557U1H220JZ01D	
27pF(270)	±5%(J)		GRM0337U1E270JD01D	GRM1557U1H270JZ01D	
33pF(330)	±5%(J)		GRM0337U1E330JD01D	GRM1557U1H330JZ01D	
39pF(390)	±5%(J)		GRM0337U1E390JD01D	GRM1557U1H390JZ01D	
47pF(470)	±5%(J)		GRM0337U1E470JD01D	GRM1557U1H470JZ01D	
56pF(560)	±5%(J)		GRM0337U1E560JD01D	GRM1557U1H560JZ01D	
68pF(680)	±5%(J)		GRM0337U1E680JD01D	GRM1557U1H680JZ01D	
82pF(820)	±5%(J)		GRM0337U1E820JD01D	GRM1557U1H820JZ01D	
100pF(101)	±5%(J)		GRM0337U1E101JD01D	GRM1557U1H101JZ01D	
120pF(121)	±5%(J)			GRM1557U1H121JZ01D	
150pF(151)	±5%(J)			GRM1557U1H151JZ01D	
180pF(181)	±5%(J)			GRM1557U1H181JZ01D	
1200pF(122)	±5%(J)				GRM1557U1A122JA01D
1500pF(152)	±5%(J)				GRM1557U1A152JA01D
1800pF(182)	±5%(J)				GRM1557U1A182JA01D
2200pF(222)	±5%(J)				GRM1557U1A222JA01D
2700pF(272)	±5%(J)				GRM1557U1A272JA01D
3300pF(332)	±5%(J)				GRM1557U1A332JA01D
3900pF(392)	±5%(J)				GRM1557U1A392JA01D
4700pF(472)	±5%(J)				GRM1557U1A472JA01D

The part number code is shown in () and Unit is shown in []. < >: EIA [inch] Code

● Temperature Compensating Type U2J(7U) Characteristics

LxW [mm]		1.6x0.8(18)<0603>	
Rated Volt. [Vdc]		50(1H)	10(1A)
Capacitance	Tolerance	Part Number	
1000pF(102)	±5%(J)	GRM1887U1H102JA01D	
1200pF(122)	±5%(J)	GRM1887U1H122JA01D	
1500pF(152)	±5%(J)	GRM1887U1H152JA01D	
1800pF(182)	±5%(J)	GRM1887U1H182JA01D	
2200pF(222)	±5%(J)	GRM1887U1H222JA01D	
2700pF(272)	±5%(J)	GRM1887U1H272JA01D	
3300pF(332)	±5%(J)	GRM1887U1H332JA01D	
3900pF(392)	±5%(J)	GRM1887U1H392JA01D	
4700pF(472)	±5%(J)	GRM1887U1H472JA01D	
5600pF(562)	±5%(J)	GRM1887U1H562JA01D	
6800pF(682)	±5%(J)	GRM1887U1H682JA01D	
8200pF(822)	±5%(J)	GRM1887U1H822JA01D	
10000pF(103)	±5%(J)	GRM1887U1H103JA01D	
12000pF(123)	±5%(J)		GRM1887U1A123JA01D
15000pF(153)	±5%(J)		GRM1887U1A153JA01D
18000pF(183)	±5%(J)		GRM1887U1A183JA01D
22000pF(223)	±5%(J)		GRM1887U1A223JA01D

LxW [mm]		2.0x1.25(21)<0805>		3.2x1.6(31)<1206>
Rated Volt. [Vdc]		50(1H)	10(1A)	50(1H)
Capacitance	Tolerance	Part Number		
10000pF(103)	±5%(J)	GRM2167U1H103JA01D		
12000pF(123)	±5%(J)	GRM2167U1H123JA01D		
15000pF(153)	±5%(J)	GRM2167U1H153JA01D		
18000pF(183)	±5%(J)	GRM2167U1H183JA01D		
22000pF(223)	±5%(J)	GRM2197U1H223JA01D		
27000pF(273)	±5%(J)	GRM2197U1H273JA01D		
33000pF(333)	±5%(J)	GRM21A7U1H333JA39L		
39000pF(393)	±5%(J)	GRM21B7U1H393JA01L		
47000pF(473)	±5%(J)	GRM21B7U1H473JA01L		
56000pF(563)	±5%(J)		GRM2197U1A563JA01D	GRM3197U1H563JA01D
68000pF(683)	±5%(J)		GRM21B7U1A683JA01L	GRM31M7U1H683JA01L
82000pF(823)	±5%(J)		GRM21B7U1A823JA01L	GRM31M7U1H823JA01L
100000pF(104)	±5%(J)		GRM21B7U1A104JA01L	GRM31M7U1H104JA01L

The part number code is shown in () and Unit is shown in []. < >: EIA [inch] Code

● Temperature Compensating Type U2J(7U) Characteristics Low Profile

LxW [mm]		1.6x0.8(18)<0603>	
Rated Volt. [Vdc]		50(1H)	10(1A)
Capacitance	Tolerance	Part Number	
2200pF(222)	±5%(J)	GRM1857U1H222JA44D	
2700pF(272)	±5%(J)	GRM1857U1H272JA44D	
3300pF(332)	±5%(J)	GRM1857U1H332JA44D	
3900pF(392)	±5%(J)	GRM1857U1H392JA44D	
4700pF(472)	±5%(J)	GRM1857U1H472JA44D	
5600pF(562)	±5%(J)		GRM1857U1A562JA44D
6800pF(682)	±5%(J)		GRM1857U1A682JA44D
8200pF(822)	±5%(J)		GRM1857U1A822JA44D
10000pF(103)	±5%(J)		GRM1857U1A103JA44D

LxW [mm]		2.0x1.25(21)<0805>		3.2x1.6(31)<1206>
Rated Volt. [Vdc]		50(1H)	10(1A)	50(1H)
Capacitance	Tolerance	Part Number		
10000pF(103)	±5%(J)	GRM2167U1H103JA01D		
12000pF(123)	±5%(J)	GRM2167U1H123JA01D		
15000pF(153)	±5%(J)	GRM2167U1H153JA01D		
18000pF(183)	±5%(J)	GRM2167U1H183JA01D		
22000pF(223)	±5%(J)	GRM2197U1H223JA01D		
27000pF(273)	±5%(J)	GRM2197U1H273JA01D		
33000pF(333)	±5%(J)	GRM21A7U1H333JA39L		
56000pF(563)	±5%(J)		GRM2197U1A563JA01D	GRM3197U1H563JA01D
68000pF(683)	±5%(J)			GRM31M7U1H683JA01L
82000pF(823)	±5%(J)			GRM31M7U1H823JA01L
100000pF(104)	±5%(J)			GRM31M7U1H104JA01L

The part number code is shown in () and Unit is shown in []. < >: EIA [inch] Code

● Temperature Compensating Type P2H(6P) Characteristics

LxW [mm]		1.0x0.5(15)<0402>	
Rated Volt. [Vdc]		50(1H)	
Capacitance	Tolerance	Part Number	
1.0pF(1R0)	±0.25pF(C)	GRM1556P1H1R0CZ01D	
2.0pF(2R0)	±0.25pF(C)	GRM1556P1H2R0CZ01D	
3.0pF(3R0)	±0.25pF(C)	GRM1556P1H3R0CZ01D	
4.0pF(4R0)	±0.25pF(C)	GRM1556P1H4R0CZ01D	
5.0pF(5R0)	±0.25pF(C)	GRM1556P1H5R0CZ01D	
6.0pF(6R0)	±0.5pF(D)	GRM1556P1H6R0DZ01D	
7.0pF(7R0)	±0.5pF(D)	GRM1556P1H7R0DZ01D	
8.0pF(8R0)	±0.5pF(D)	GRM1556P1H8R0DZ01D	
9.0pF(9R0)	±0.5pF(D)	GRM1556P1H9R0DZ01D	
10pF(100)	±5%(J)	GRM1556P1H100JZ01D	
12pF(120)	±5%(J)	GRM1556P1H120JZ01D	
15pF(150)	±5%(J)	GRM1556P1H150JZ01D	
18pF(180)	±5%(J)	GRM1556P1H180JZ01D	
22pF(220)	±5%(J)	GRM1556P1H220JZ01D	
27pF(270)	±5%(J)	GRM1556P1H270JZ01D	

The part number code is shown in () and Unit is shown in []. < >: EIA [inch] Code

● Temperature Compensating Type R2H(6R) Characteristics

LxW [mm]		0.6x0.3(03)<0201>	1.0x0.5(15)<0402>
Rated Volt. [Vdc]		25(1E)	50(1H)
Capacitance	Tolerance	Part Number	
1.0pF(1R0)	±0.25pF(C)	GRM0336R1E1R0CD01D	GRM1556R1H1R0CD01D
2.0pF(2R0)	±0.25pF(C)	GRM0336R1E2R0CD01D	GRM1556R1H2R0CZ01D
3.0pF(3R0)	±0.25pF(C)	GRM0336R1E3R0CD01D	GRM1556R1H3R0CZ01D
4.0pF(4R0)	±0.25pF(C)	GRM0336R1E4R0CD01D	GRM1556R1H4R0CZ01D
5.0pF(5R0)	±0.25pF(C)	GRM0336R1E5R0CD01D	GRM1556R1H5R0CZ01D
6.0pF(6R0)	±0.5pF(D)	GRM0336R1E6R0DD01D	GRM1556R1H6R0DZ01D
7.0pF(7R0)	±0.5pF(D)	GRM0336R1E7R0DD01D	GRM1556R1H7R0DZ01D
8.0pF(8R0)	±0.5pF(D)	GRM0336R1E8R0DD01D	GRM1556R1H8R0DZ01D
9.0pF(9R0)	±0.5pF(D)	GRM0336R1E9R0DD01D	GRM1556R1H9R0DZ01D
10pF(100)	±5%(J)	GRM0336R1E100JD01D	GRM1556R1H100JZ01D
12pF(120)	±5%(J)	GRM0336R1E120JD01D	GRM1556R1H120JZ01D
15pF(150)	±5%(J)	GRM0336R1E150JD01D	GRM1556R1H150JZ01D
18pF(180)	±5%(J)	GRM0336R1E180JD01D	GRM1556R1H180JZ01D
22pF(220)	±5%(J)	GRM0336R1E220JD01D	GRM1556R1H220JZ01D
27pF(270)	±5%(J)	GRM0336R1E270JD01D	GRM1556R1H270JZ01D
33pF(330)	±5%(J)	GRM0336R1E330JD01D	GRM1556R1H330JZ01D
39pF(390)	±5%(J)	GRM0336R1E390JD01D	
47pF(470)	±5%(J)	GRM0336R1E470JD01D	
56pF(560)	±5%(J)	GRM0336R1E560JD01D	
68pF(680)	±5%(J)	GRM0336R1E680JD01D	
82pF(820)	±5%(J)	GRM0336R1E820JD01D	
100pF(101)	±5%(J)	GRM0336R1E101JD01D	

The part number code is shown in () and Unit is shown in []. < >: EIA [inch] Code

● Temperature Compensating Type S2H(6S) Characteristics

LxW [mm]		0.6x0.3(03)<0201>	1.0x0.5(15)<0402>
Rated Volt. [Vdc]		25(1E)	50(1H)
Capacitance	Tolerance	Part Number	
1.0pF(1R0)	±0.25pF(C)	GRM0336S1E1R0CD01D	GRM1556S1H1R0CD01D
2.0pF(2R0)	±0.25pF(C)	GRM0336S1E2R0CD01D	GRM1556S1H2R0CZ01D
3.0pF(3R0)	±0.25pF(C)	GRM0336S1E3R0CD01D	GRM1556S1H3R0CZ01D
4.0pF(4R0)	±0.25pF(C)	GRM0336S1E4R0CD01D	GRM1556S1H4R0CZ01D
5.0pF(5R0)	±0.25pF(C)	GRM0336S1E5R0CD01D	GRM1556S1H5R0CZ01D
6.0pF(6R0)	±0.5pF(D)	GRM0336S1E6R0DD01D	GRM1556S1H6R0DZ01D
7.0pF(7R0)	±0.5pF(D)	GRM0336S1E7R0DD01D	GRM1556S1H7R0DZ01D
8.0pF(8R0)	±0.5pF(D)	GRM0336S1E8R0DD01D	GRM1556S1H8R0DZ01D
9.0pF(9R0)	±0.5pF(D)	GRM0336S1E9R0DD01D	GRM1556S1H9R0DZ01D
10pF(100)	±5%(J)	GRM0336S1E100JD01D	GRM1556S1H100JZ01D
12pF(120)	±5%(J)	GRM0336S1E120JD01D	GRM1556S1H120JZ01D
15pF(150)	±5%(J)	GRM0336S1E150JD01D	GRM1556S1H150JZ01D
18pF(180)	±5%(J)	GRM0336S1E180JD01D	GRM1556S1H180JZ01D
22pF(220)	±5%(J)	GRM0336S1E220JD01D	GRM1556S1H220JZ01D
27pF(270)	±5%(J)	GRM0336S1E270JD01D	GRM1556S1H270JZ01D
33pF(330)	±5%(J)	GRM0336S1E330JD01D	GRM1556S1H330JZ01D
39pF(390)	±5%(J)	GRM0336S1E390JD01D	GRM1556S1H390JZ01D
47pF(470)	±5%(J)	GRM0336S1E470JD01D	
56pF(560)	±5%(J)	GRM0336S1E560JD01D	
68pF(680)	±5%(J)	GRM0336S1E680JD01D	
82pF(820)	±5%(J)	GRM0336S1E820JD01D	
100pF(101)	±5%(J)	GRM0336S1E101JD01D	

The part number code is shown in () and Unit is shown in []. < >: EIA [inch] Code

△Note • This PDF catalog is downloaded from the website of Murata Manufacturing co., Ltd. Therefore, it's specifications are subject to change or our products in it may be discontinued without advance notice. Please check with our sales representatives or product engineers before ordering.
• This PDF catalog has only typical specifications because there is no space for detailed specifications. Therefore, please approve our product specifications or transact the approval sheet for product specifications before ordering.

● Temperature Compensating Type T2H(6T) Characteristics

LxW [mm]		0.6x0.3(03)<0201>	1.0x0.5(15)<0402>
Rated Volt. [Vdc]		25(1E)	50(1H)
Capacitance	Tolerance	Part Number	
1.0pF(1R0)	±0.25pF(C)	GRM0336T1E1R0CD01D	GRM1556T1H1R0CD01D
2.0pF(2R0)	±0.25pF(C)	GRM0336T1E2R0CD01D	GRM1556T1H2R0CD01D
3.0pF(3R0)	±0.25pF(C)	GRM0336T1E3R0CD01D	GRM1556T1H3R0CD01D
4.0pF(4R0)	±0.25pF(C)	GRM0336T1E4R0CD01D	GRM1556T1H4R0CD01D
5.0pF(5R0)	±0.25pF(C)	GRM0336T1E5R0CD01D	GRM1556T1H5R0CD01D
6.0pF(6R0)	±0.5pF(D)	GRM0336T1E6R0DD01D	GRM1556T1H6R0DD01D
7.0pF(7R0)	±0.5pF(D)	GRM0336T1E7R0DD01D	GRM1556T1H7R0DD01D
8.0pF(8R0)	±0.5pF(D)	GRM0336T1E8R0DD01D	GRM1556T1H8R0DD01D
9.0pF(9R0)	±0.5pF(D)	GRM0336T1E9R0DD01D	GRM1556T1H9R0DD01D
10pF(100)	±5%(J)	GRM0336T1E100JD01D	GRM1556T1H100JD01D
12pF(120)	±5%(J)	GRM0336T1E120JD01D	GRM1556T1H120JD01D
15pF(150)	±5%(J)	GRM0336T1E150JD01D	GRM1556T1H150JD01D
18pF(180)	±5%(J)	GRM0336T1E180JD01D	GRM1556T1H180JD01D
22pF(220)	±5%(J)	GRM0336T1E220JD01D	GRM1556T1H220JD01D
27pF(270)	±5%(J)	GRM0336T1E270JD01D	GRM1556T1H270JD01D
33pF(330)	±5%(J)	GRM0336T1E330JD01D	GRM1556T1H330JD01D
39pF(390)	±5%(J)	GRM0336T1E390JD01D	GRM1556T1H390JD01D
47pF(470)	±5%(J)	GRM0336T1E470JD01D	GRM1556T1H470JD01D
56pF(560)	±5%(J)	GRM0336T1E560JD01D	GRM1556T1H560JD01D
68pF(680)	±5%(J)	GRM0336T1E680JD01D	GRM1556T1H680JD01D
82pF(820)	±5%(J)	GRM0336T1E820JD01D	GRM1556T1H820JD01D
100pF(101)	±5%(J)	GRM0336T1E101JD01D	GRM1556T1H101JD01D

The part number code is shown in () and Unit is shown in []. < >: EIA [inch] Code

● High Dielectric Constant Type X7R(R7) Characteristics

LxW [mm]		0.4x0.2(02)<01005>
Rated Volt. [Vdc]		10(1A)
Capacitance	Tolerance	Part Number
68pF(680)	±10%(K)	GRM022R71A680KA01L
100pF(101)	±10%(K)	GRM022R71A101KA01L
150pF(151)	±10%(K)	GRM022R71A151KA01L
220pF(221)	±10%(K)	GRM022R71A221KA01L
330pF(331)	±10%(K)	GRM022R71A331KA01L
470pF(471)	±10%(K)	GRM022R71A471KA01L

LxW [mm]		0.6x0.3(03)<0201>		
Rated Volt. [Vdc]		25(1E)	16(1C)	10(1A)
Capacitance	Tolerance	Part Number		
100pF(101)	±10%(K)	GRM033R71E101KA01D		
150pF(151)	±10%(K)	GRM033R71E151KA01D		
220pF(221)	±10%(K)	GRM033R71E221KA01D		
330pF(331)	±10%(K)	GRM033R71E331KA01D		
470pF(471)	±10%(K)	GRM033R71E471KA01D		
680pF(681)	±10%(K)	GRM033R71E681KA01D		
1000pF(102)	±10%(K)	GRM033R71E102KA01D		
1500pF(152)	±10%(K)	GRM033R71E152KA01D		
2200pF(222)	±10%(K)		GRM033R71C222KA88D	
3300pF(332)	±10%(K)		GRM033R71C332KA88D	
4700pF(472)	±10%(K)			GRM033R71A472KA01D
6800pF(682)	±10%(K)			GRM033R71A682KA01D
10000pF(103)	±10%(K)			GRM033R71A103KA01D

LxW [mm]		1.0x0.5(15)<0402>			
Rated Volt. [Vdc]		100(2A)	50(1H)	25(1E)	16(1C)
Capacitance	Tolerance	Part Number			
220pF(221)	±10%(K)	GRM155R72A221KA01D	GRM155R71H221KA01D		
330pF(331)	±10%(K)	GRM155R72A331KA01D	GRM155R71H331KA01D		
470pF(471)	±10%(K)	GRM155R72A471KA01D	GRM155R71H471KA01D		
680pF(681)	±10%(K)	GRM155R72A681KA01D	GRM155R71H681KA01D		
1000pF(102)	±10%(K)	GRM155R72A102KA01D	GRM155R71H102KA01D		
1500pF(152)	±10%(K)	GRM155R72A152KA01D	GRM155R71H152KA01D		
2200pF(222)	±10%(K)	GRM155R72A222KA01D	GRM155R71H222KA01D		
3300pF(332)	±10%(K)	GRM155R72A332KA01D	GRM155R71H332KA01D		
4700pF(472)	±10%(K)	GRM155R72A472KA01D	GRM155R71H472KA01D	GRM155R71E472KA01D	
6800pF(682)	±10%(K)		GRM155R71H682KA88D	GRM155R71E682KA01D	
10000pF(103)	±10%(K)		GRM155R71H103KA88D	GRM155R71E103KA01D	
15000pF(153)	±10%(K)		GRM155R71H153KA12D	GRM155R71E153KA61D	GRM155R71C153KA01D
22000pF(223)	±10%(K)		GRM155R71H223KA12D	GRM155R71E223KA61D	GRM155R71C223KA01D
33000pF(333)	±10%(K)			GRM155R71E333KA88D	GRM155R71C333KA01D
47000pF(473)	±10%(K)			GRM155R71E473KA88D	GRM155R71C473KA01D
68000pF(683)	±10%(K)				GRM155R71C683KA88D
0.10μF(104)	±10%(K)				GRM155R71C104KA88D

LxW [mm]		1.0x0.5(15)<0402>
Rated Volt. [Vdc]		10(1A)
Capacitance	Tolerance	Part Number
68000pF(683)	±10%(K)	GRM155R71A683KA01D
0.10μF(104)	±10%(K)	GRM155R71A104KA01D

The part number code is shown in () and Unit is shown in []. < >: EIA [inch] Code

△Note • This PDF catalog is downloaded from the website of Murata Manufacturing co., Ltd. Therefore, it's specifications are subject to change or our products in it may be discontinued without advance notice. Please check with our sales representatives or product engineers before ordering.
 • This PDF catalog has only typical specifications because there is no space for detailed specifications. Therefore, please approve our product specifications or transact the approval sheet for product specifications before ordering.

● High Dielectric Constant Type X7R(R7)/X7S(C7) Characteristics

LxW [mm]		1.6x0.8(18)<0603>			
Rated Volt. [Vdc]		100(2A)	50(1H)	25(1E)	16(1C)
Capacitance	Tolerance	Part Number			
220pF(221)	±10%(K)	GRM188R72A221KA01D	GRM188R71H221KA01D		
330pF(331)	±10%(K)	GRM188R72A331KA01D	GRM188R71H331KA01D		
470pF(471)	±10%(K)	GRM188R72A471KA01D	GRM188R71H471KA01D		
680pF(681)	±10%(K)	GRM188R72A681KA01D	GRM188R71H681KA01D		
1000pF(102)	±10%(K)	GRM188R72A102KA01D	GRM188R71H102KA01D		
1500pF(152)	±10%(K)	GRM188R72A152KA01D	GRM188R71H152KA01D		
2200pF(222)	±10%(K)	GRM188R72A222KA01D	GRM188R71H222KA01D		
3300pF(332)	±10%(K)	GRM188R72A332KA01D	GRM188R71H332KA01D		
4700pF(472)	±10%(K)	GRM188R72A472KA01D	GRM188R71H472KA01D		
6800pF(682)	±10%(K)	GRM188R72A682KA01D	GRM188R71H682KA01D		
10000pF(103)	±10%(K)	GRM188R72A103KA01D	GRM188R71H103KA01D	GRM188R71E103KA01D	
15000pF(153)	±10%(K)		GRM188R71H153KA01D	GRM188R71E153KA01D	
22000pF(223)	±10%(K)		GRM188R71H223KA01D	GRM188R71E223KA01D	
33000pF(333)	±10%(K)		GRM188R71H333KA61D	GRM188R71E333KA01D	
47000pF(473)	±10%(K)		GRM188R71H473KA61D	GRM188R71E473KA01D	
68000pF(683)	±10%(K)		GRM188R71H683KA93D	GRM188R71E683KA01D	
0.10μF(104)	±10%(K)	GRM188R72A104KA35D	GRM188R71H104KA93D	GRM188R71E104KA01D	
0.15μF(154)	±10%(K)			GRM188R71E154KA01D	GRM188R71C154KA01D
0.22μF(224)	±10%(K)			GRM188R71E224KA88D	GRM188R71C224KA01D
0.33μF(334)	±10%(K)				GRM188R71C334KA01D
0.47μF(474)	±10%(K)			GRM188R71E474KA12D	GRM188R71C474KA88D
1.0μF(105)	±10%(K)			GRM188R71E105KA12D	GRM188R71C105KA12D

LxW [mm]		1.6x0.8(18)<0603>		
Rated Volt. [Vdc]		10(1A)	6.3(0J)	4(0G)
Capacitance	Tolerance	Part Number		
0.33μF(334)	±10%(K)	GRM188R71A334KA61D		
0.47μF(474)	±10%(K)	GRM188R71A474KA61D		
0.68μF(684)	±10%(K)	GRM188R71A684KA61D		
1.0μF(105)	±10%(K)	GRM188R71A105KA61D		
2.2μF(225)	±10%(K)	GRM188R71A225KE15D	GRM188C70J225KE20D	GRM188C70G225KE20D

The part number code is shown in () and Unit is shown in []. < >: EIA [inch] Code

● High Dielectric Constant Type X7R(R7)/X7U(E7) Characteristics

LxW [mm]		2.0x1.25(21)<0805>			
Rated Volt. [Vdc]		100(2A)	50(1H)	25(1E)	16(1C)
Capacitance	Tolerance	Part Number			
6800pF(682)	±10%(K)	GRM219R72A682KA01D			
10000pF(103)	±10%(K)	GRM21BR72A103KA01L			
15000pF(153)	±10%(K)	GRM21BR72A153KA01L			
22000pF(223)	±10%(K)	GRM21BR72A223KA01L			
33000pF(333)	±10%(K)	GRM21BR72A333KA01L	GRM219R71H333KA01D		
47000pF(473)	±10%(K)	GRM21BR72A473KA01L	GRM21BR71H473KA01L		
68000pF(683)	±10%(K)		GRM21BR71H683KA01L	GRM219R71E683KA01D	
0.10μF(104)	±10%(K)		GRM21BR71H104KA01L	GRM21BR71E104KA01L	
0.15μF(154)	±10%(K)		GRM21BR71H154KA01L	GRM21BR71E154KA01L	
0.22μF(224)	±10%(K)	GRM21AR72A224KAC5L	GRM21BR71H224KA01L	GRM21BR71E224KA01L	
0.33μF(334)	±10%(K)	GRM21AR72A334KAC5L	GRM219R71H334KA88D	GRM21BR71E334KA01L	
0.47μF(474)	±10%(K)	GRM21BR72A474KA73L	GRM21BR71H474KA88L	GRM219R71E474KA88D	
0.68μF(684)	±10%(K)			GRM219R71E684KA88D	GRM219R71C684KA01D
1.0μF(105)	±10%(K)		GRM21BR71H105KA12L	GRM21BR71E105KA99L GRM219R71E105KA88D	GRM21BR71C105KA01L
2.2μF(225)	±10%(K)			GRM21BR71E225KA73L	GRM21BR71C225KA12L
4.7μF(475)	±10%(K)				GRM21BR71C475KA73L

LxW [mm]		2.0x1.25(21)<0805>		
Rated Volt. [Vdc]		10(1A)	6.3(0J)	4(0G)
Capacitance	Tolerance	Part Number		
2.2μF(225)	±10%(K)	GRM21BR71A225KA01L		
4.7μF(475)	±10%(K)	GRM21BR71A475KA73L		
10μF(106)	±10%(K)	GRM21BR71A106KE51L	GRM21BR70J106KE76L	
22μF(226)	±20%(M)			GRM21BE70G226ME51L

The part number code is shown in () and Unit is shown in []. < >: EIA [inch] Code

△Note • This PDF catalog is downloaded from the website of Murata Manufacturing co., ltd. Therefore, it's specifications are subject to change or our products in it may be discontinued without advance notice. Please check with our sales representatives or product engineers before ordering.
• This PDF catalog has only typical specifications because there is no space for detailed specifications. Therefore, please approve our product specifications or transact the approval sheet for product specifications before ordering.

● High Dielectric Constant Type X7R(R7)/X7U(E7) Characteristics

LxW [mm]		3.2x1.6(31)<1206>			
Rated Volt. [Vdc]		100(2A)	50(1H)	25(1E)	16(1C)
Capacitance	Tolerance	Part Number			
15000pF(153)	±10%(K)	GRM319R72A153KA01L			
22000pF(223)	±10%(K)	GRM31MR72A223KA01L			
33000pF(333)	±10%(K)	GRM31MR72A333KA01L			
47000pF(473)	±10%(K)	GRM31MR72A473KA01L			
68000pF(683)	±10%(K)	GRM31MR72A683KA01L			
0.10μF(104)	±10%(K)	GRM319R72A104KA01D			
0.15μF(154)	±10%(K)	GRM31MR72A154KA01L	GRM31MR71H154KA01L		
0.22μF(224)	±10%(K)	GRM31MR72A224KA01L	GRM31MR71H224KA01L		
0.33μF(334)	±10%(K)		GRM319R71H334KA01D		
0.47μF(474)	±10%(K)	GRM31MR72A474KA35L	GRM31MR71H474KA01L		
0.68μF(684)	±10%(K)	GRM31MR72A684KA35L	GRM31MR71H684KA88L		
1.0μF(105)	±10%(K)	GRM31CR72A105KA01L	GRM31MR71H105KA88L		
2.2μF(225)	±10%(K)		GRM31CR71H225KA88L	GRM31MR71E225KA93L	GRM31MR71C225KA35L
4.7μF(475)	±10%(K)		GRM31CR71H475KA12L	GRM31CR71E475KA88L	GRM31CR71C475KA01L
10μF(106)	±10%(K)			GRM31CR71E106KA12L	GRM31CR71C106KAC7L

LxW [mm]		3.2x1.6(31)<1206>		
Rated Volt. [Vdc]		10(1A)	6.3(0J)	4(0G)
Capacitance	Tolerance	Part Number		
10μF(106)	±10%(K)	GRM31CR71A106KA01L		
22μF(226)	±20%(M)	GRM31CR71A226ME15L	GRM31CR70J226ME19L	
47μF(476)	±20%(M)			GRM31CE70G476ME15L

LxW [mm]		3.2x2.5(32)<1210>			
Rated Volt. [Vdc]		100(2A)	50(1H)	35(YA)	25(1E)
Capacitance	Tolerance	Part Number			
0.68μF(684)	±10%(K)	GRM32CR72A684KA01L	GRM32NR71H684KA01L		
1.0μF(105)	±10%(K)	GRM32CR72A105KA35L			
2.2μF(225)	±10%(K)	GRM32ER72A225KA35L			
4.7μF(475)	±10%(K)		GRM32ER71H475KA88L		
10μF(106)	±10%(K)			GRM32ER7YA106KA12L	GRM32DR71E106KA12L
22μF(226)	±20%(M)				GRM32ER71E226ME15L

LxW [mm]		3.2x2.5(32)<1210>		
Rated Volt. [Vdc]		16(1C)	10(1A)	6.3(0J)
Capacitance	Tolerance	Part Number		
22μF(226)	±20%(M)	GRM32ER71C226ME18L		
47μF(476)	±20%(M)		GRM32ER71A476ME15L	GRM32ER70J476ME20L

The part number code is shown in () and Unit is shown in []. < >: EIA [inch] Code

● High Dielectric Constant Type X7R(R7)/X7T(D7) Characteristics Low Profile

LxW [mm]		1.0x0.5(15)<0402>		
Rated Volt. [Vdc]		50(1H)	25(1E)	16(1C)
Capacitance	Tolerance	Part Number		
220pF(221)	±10%(K)	GRM15XR71H221KA86D		
330pF(331)	±10%(K)	GRM15XR71H331KA86D		
470pF(471)	±10%(K)	GRM15XR71H471KA86D		
680pF(681)	±10%(K)	GRM15XR71H681KA86D		
1000pF(102)	±10%(K)	GRM15XR71H102KA86D		
1500pF(152)	±10%(K)	GRM15XR71H152KA86D		
2200pF(222)	±10%(K)		GRM15XR71E222KA86D	
3300pF(332)	±10%(K)			GRM15XR71C332KA86D
4700pF(472)	±10%(K)			GRM15XR71C472KA86D
6800pF(682)	±10%(K)			GRM15XR71C682KA86D
10000pF(103)	±10%(K)			GRM15XR71C103KA86D

LxW [mm]		1.6x0.8(18)<0603>
Rated Volt. [Vdc]		10(1A)
Capacitance	Tolerance	Part Number
1.0μF(105)	±10%(K)	GRM185D71A105KE36D

LxW [mm]		2.0x1.25(21)<0805>			
Rated Volt. [Vdc]		100(2A)	50(1H)	25(1E)	16(1C)
Capacitance	Tolerance	Part Number			
6800pF(682)	±10%(K)	GRM219R72A682KA01D			
33000pF(333)	±10%(K)		GRM219R71H333KA01D		
68000pF(683)	±10%(K)			GRM219R71E683KA01D	
0.22μF(224)	±10%(K)	GRM21AR72A224KAC5L			
0.33μF(334)	±10%(K)	GRM21AR72A334KAC5L	GRM219R71H334KA88D		
0.47μF(474)	±10%(K)			GRM219R71E474KA88D	
0.68μF(684)	±10%(K)			GRM219R71E684KA88D	GRM219R71C684KA01D
1.0μF(105)	±10%(K)			GRM219R71E105KA88D	

LxW [mm]		3.2x1.6(31)<1206>			
Rated Volt. [Vdc]		100(2A)	50(1H)	25(1E)	16(1C)
Capacitance	Tolerance	Part Number			
15000pF(153)	±10%(K)	GRM319R72A153KA01L			
22000pF(223)	±10%(K)	GRM31MR72A223KA01L			
33000pF(333)	±10%(K)	GRM31MR72A333KA01L			
47000pF(473)	±10%(K)	GRM31MR72A473KA01L			
68000pF(683)	±10%(K)	GRM31MR72A683KA01L			
0.10μF(104)	±10%(K)	GRM319R72A104KA01D			
0.15μF(154)	±10%(K)	GRM31MR72A154KA01L	GRM31MR71H154KA01L		
0.22μF(224)	±10%(K)	GRM31MR72A224KA01L	GRM31MR71H224KA01L		
0.33μF(334)	±10%(K)		GRM319R71H334KA01D		
0.47μF(474)	±10%(K)	GRM31MR72A474KA35L	GRM31MR71H474KA01L		
0.68μF(684)	±10%(K)	GRM31MR72A684KA35L	GRM31MR71H684KA88L		
1.0μF(105)	±10%(K)		GRM31MR71H105KA88L		
2.2μF(225)	±10%(K)			GRM31MR71E225KA93L	GRM31MR71C225KA35L

LxW [mm]		3.2x2.5(32)<1210>	
Rated Volt. [Vdc]		100(2A)	50(1H)
Capacitance	Tolerance	Part Number	
0.68μF(684)	±10%(K)	GRM32CR72A684KA01L	GRM32NR71H684KA01L
1.0μF(105)	±10%(K)	GRM32CR72A105KA35L	

The part number code is shown in () and Unit is shown in []. < >: EIA [inch] Code

△Note • This PDF catalog is downloaded from the website of Murata Manufacturing co., ltd. Therefore, it's specifications are subject to change or our products in it may be discontinued without advance notice. Please check with our sales representatives or product engineers before ordering.
• This PDF catalog has only typical specifications because there is no space for detailed specifications. Therefore, please approve our product specifications or transact the approval sheet for product specifications before ordering.

● High Dielectric Constant Type X6S(C8) Characteristics

LxW [mm]		0.6x0.3(03)<0201>	
Rated Volt. [Vdc]		6.3(0J)	2.5(0E)
Capacitance	Tolerance	Part Number	
15000pF(153)	±10%(K)	GRM033C80J153KE01D	
22000pF(223)	±10%(K)	GRM033C80J223KE01D	
33000pF(333)	±10%(K)	GRM033C80J333KE01D	
47000pF(473)	±10%(K)	GRM033C80J473KE19D	
0.10μF(104)	±10%(K)	GRM033C80J104KE84D	
0.22μF(224)	±10%(K)	GRM033C80E224ME15D	

LxW [mm]		1.0x0.5(15)<0402>		
Rated Volt. [Vdc]		25(1E)	6.3(0J)	4(0G)
Capacitance	Tolerance	Part Number		
68000pF(683)	±10%(K)	GRM155C81E683KA12D		
0.10μF(104)	±10%(K)	GRM155C81E104KA12D		
0.15μF(154)	±10%(K)		GRM155C80J154KE01D	GRM155C80G154KE01D
0.22μF(224)	±10%(K)		GRM155C80J224KE01D	GRM155C80G224KE01D
0.33μF(334)	±10%(K)		GRM155C80J334KE01D	GRM155C80G334KE01D
0.47μF(474)	±10%(K)		GRM155C80J474KE19D	GRM155C80G474KE01D
0.68μF(684)	±10%(K)			GRM155C80G684KE19D

LxW [mm]		1.6x0.8(18)<0603>			
Rated Volt. [Vdc]		10(1A)	6.3(0J)	4(0G)	2.5(0E)
Capacitance	Tolerance	Part Number			
1.0μF(105)	±10%(K)			GRM188C80G105MA01D	
2.2μF(225)	±10%(K)	GRM188C81A225KE34D	GRM188C80J225KE19D		
4.7μF(475)	±10%(K)			GRM188C80G475KE19D	
10μF(106)	±20%(M)				GRM188C80E106ME47D

LxW [mm]		2.0x1.25(21)<0805>			
Rated Volt. [Vdc]		25(1E)	16(1C)	10(1A)	6.3(0J)
Capacitance	Tolerance	Part Number			
1.0μF(105)	±10%(K)		GRM216C81C105KA12D		
2.2μF(225)	±10%(K)		GRM219C81C225KA12D		
4.7μF(475)	±10%(K)	GRM21BC81E475KA12L	GRM21BC81C475KA88L	GRM219C81A475KE34D	GRM219C80J475KE19D
10μF(106)	±10%(K)			GRM21BC81A106KE18L	GRM21BC80J106KE19L
					GRM219C80J106KE39D

LxW [mm]		2.0x1.25(21)<0805>	
Rated Volt. [Vdc]		4(0G)	
Capacitance	Tolerance	Part Number	
10μF(106)	±10%(K)	GRM219C80G106KE19D	
22μF(226)	±20%(M)	GRM21BC80G226ME39L	

The part number code is shown in () and Unit is shown in []. < >: EIA [inch] Code

● High Dielectric Constant Type X6S(C8)/X6T(D8) Characteristics

LxW [mm]		3.2x1.6(31)<1206>			
Rated Volt. [Vdc]		25(1E)	16(1C)	10(1A)	6.3(0J)
Capacitance	Tolerance	Part Number			
2.2μF(225)	±10%(K)		GRM316C81C225KA12D		
4.7μF(475)	±10%(K)		GRM319C81C475KA12D		
10μF(106)	±10%(K)	GRM31CC81E106KE15L			
22μF(226)	±20%(M)			GRM31CC81A226ME19L	GRM31CC80J226ME19L
47μF(476)	±20%(M)				GRM31CC80J476ME18L

LxW [mm]		3.2x1.6(31)<1206>	
Rated Volt. [Vdc]		4(0G)	
Capacitance	Tolerance	Part Number	
47μF(476)	±20%(M)	GRM31CC80G476ME19L	
100μF(107)	±20%(M)	GRM31CD80G107ME39L	

LxW [mm]		3.2x2.5(32)<1210>		
Rated Volt. [Vdc]		25(1E)	10(1A)	6.3(0J)
Capacitance	Tolerance	Part Number		
10μF(106)	±10%(K)	GRM32DC81E106KA12L		
22μF(226)	±20%(M)	GRM32EC81E226ME15L		
47μF(476)	±20%(M)		GRM32EC81A476ME19L	GRM32EC80J476ME64L

The part number code is shown in () and Unit is shown in []. < >: EIA [inch] Code

● High Dielectric Constant Type X6S(C8) Characteristics Low Profile

LxW [mm]		1.6x0.8(18)<0603>	
Rated Volt. [Vdc]		10(1A)	6.3(0J)
Capacitance	Tolerance	Part Number	
1.0μF(105)	±10%(K)	GRM185C81A105KE36D	GRM185C80J105KE26D

LxW [mm]		2.0x1.25(21)<0805>			
Rated Volt. [Vdc]		16(1C)	10(1A)	6.3(0J)	4(0G)
Capacitance	Tolerance	Part Number			
1.0μF(105)	±10%(K)	GRM216C81C105KA12D			
2.2μF(225)	±10%(K)	GRM219C81C225KA12D			
4.7μF(475)	±10%(K)		GRM219C81A475KE34D	GRM219C80J475KE19D	
10μF(106)	±10%(K)			GRM219C80J106KE39D	GRM219C80G106KE19D

LxW [mm]		3.2x1.6(31)<1206>	
Rated Volt. [Vdc]		16(1C)	
Capacitance	Tolerance	Part Number	
2.2μF(225)	±10%(K)	GRM316C81C225KA12D	
4.7μF(475)	±10%(K)	GRM319C81C475KA12D	

LxW [mm]		3.2x2.5(32)<1210>	
Rated Volt. [Vdc]		25(1E)	
Capacitance	Tolerance	Part Number	
10μF(106)	±10%(K)	GRM32DC81E106KA12L	

The part number code is shown in () and Unit is shown in []. < >: EIA [inch] Code

● High Dielectric Constant Type X5R(R6) Characteristics

LxW [mm]		0.4x0.2(02)<01005>	
Rated Volt. [Vdc]		10(1A)	6.3(0J)
Capacitance	Tolerance	Part Number	
68pF(680)	±10%(K)	GRM022R61A680KA01L	
100pF(101)	±10%(K)	GRM022R61A101KA01L	
150pF(151)	±10%(K)	GRM022R61A151KA01L	
220pF(221)	±10%(K)	GRM022R61A221KA01L	
330pF(331)	±10%(K)	GRM022R61A331KA01L	
470pF(471)	±10%(K)	GRM022R61A471KA01L	
680pF(681)	±10%(K)		GRM022R60J681KE19L
1000pF(102)	±10%(K)		GRM022R60J102KE19L
1500pF(152)	±10%(K)		GRM022R60J152KE19L
2200pF(222)	±10%(K)		GRM022R60J222KE19L
3300pF(332)	±10%(K)		GRM022R60J332KE19L
4700pF(472)	±10%(K)		GRM022R60J472KE19L
6800pF(682)	±10%(K)		GRM022R60J682KE19L
10000pF(103)	±10%(K)		GRM022R60J103KE19L

LxW [mm]		0.6x0.3(03)<0201>			
Rated Volt. [Vdc]		25(1E)	16(1C)	10(1A)	6.3(0J)
Capacitance	Tolerance	Part Number			
100pF(101)	±10%(K)				
150pF(151)	±10%(K)				
220pF(221)	±10%(K)				
330pF(331)	±10%(K)				
470pF(471)	±10%(K)				
680pF(681)	±10%(K)				
1000pF(102)	±10%(K)				
1500pF(152)	±10%(K)			GRM033R61A152KA01D	
2200pF(222)	±10%(K)			GRM033R61A222KA01D	
3300pF(332)	±10%(K)			GRM033R61A332KA01D	
4700pF(472)	±10%(K)			GRM033R61A472KA01D	
6800pF(682)	±10%(K)			GRM033R61A682KA01D	
10000pF(103)	±10%(K)			GRM033R61A103KA01D	
15000pF(153)	±10%(K)				GRM033R60J153KE01D
22000pF(223)	±10%(K)				GRM033R60J223KE01D
33000pF(333)	±10%(K)				GRM033R60J333KE01D
47000pF(473)	±10%(K)				GRM033R60J473KE19D
0.10μF(104)	±10%(K)			GRM033R61A104KE84D	

The part number code is shown in () and Unit is shown in []. < >: EIA [inch] Code

 : Please refer to X7R(R7) etc Characteristics.

● High Dielectric Constant Type X5R(R6) Characteristics

LxW [mm]		1.0x0.5(15)<0402>			
Rated Volt. [Vdc]		100(2A)	50(1H)	25(1E)	16(1C)
Capacitance	Tolerance	Part Number			
220pF(221)	±10%(K)				
330pF(331)	±10%(K)				
470pF(471)	±10%(K)				
680pF(681)	±10%(K)				
1000pF(102)	±10%(K)		GRM155R61H102KA01D		
1500pF(152)	±10%(K)				
2200pF(222)	±10%(K)		GRM155R61H222KA01D		
3300pF(332)	±10%(K)				
4700pF(472)	±10%(K)		GRM155R61H472KA01D		
6800pF(682)	±10%(K)				
10000pF(103)	±10%(K)				
15000pF(153)	±10%(K)				
22000pF(223)	±10%(K)				GRM155R61C223KA01D
33000pF(333)	±10%(K)				GRM155R61C333KA01D
47000pF(473)	±10%(K)				GRM155R61C473KA01D
68000pF(683)	±10%(K)			GRM155R61E683KA87D	GRM155R61C683KA88D
0.10μF(104)	±10%(K)			GRM155R61E104KA87D	GRM155R61C104KA88D

LxW [mm]		1.0x0.5(15)<0402>		
Rated Volt. [Vdc]		10(1A)	6.3(0J)	4(0G)
Capacitance	Tolerance	Part Number		
33000pF(333)	±10%(K)	GRM155R61A333KA01D		
47000pF(473)	±10%(K)	GRM155R61A473KA01D		
68000pF(683)	±10%(K)	GRM155R61A683KA01D		
0.10μF(104)	±10%(K)	GRM155R61A104KA01D		
0.15μF(154)	±10%(K)	GRM155R61A154KE19D	GRM155R60J154KE01D	
0.22μF(224)	±10%(K)	GRM155R61A224KE19D	GRM155R60J224KE01D	
0.33μF(334)	±10%(K)	GRM155R61A334KE15D	GRM155R60J334KE01D	
0.47μF(474)	±10%(K)	GRM155R61A474KE15D	GRM155R60J474KE19D	
0.68μF(684)	±10%(K)	GRM155R61A684KE15D	GRM155R60J684KE19D	
1.0μF(105)	±10%(K)	GRM155R61A105KE15D		
4.7μF(475)	±20%(M)			GRM155R60G475ME87D

The part number code is shown in () and Unit is shown in []. < >: EIA [inch] Code

□ : Please refer to X7R(R7) etc Characteristics.

△Note • This PDF catalog is downloaded from the website of Murata Manufacturing co., Ltd. Therefore, it's specifications are subject to change or our products in it may be discontinued without advance notice. Please check with our sales representatives or product engineers before ordering.
• This PDF catalog has only typical specifications because there is no space for detailed specifications. Therefore, please approve our product specifications or transact the approval sheet for product specifications before ordering.

● High Dielectric Constant Type X5R(R6) Characteristics

LxW [mm]		1.6x0.8(18)<0603>			
Rated Volt. [Vdc]		100(2A)	50(1H)	25(1E)	16(1C)
Capacitance	Tolerance	Part Number			
220pF(221)	±10%(K)				
330pF(331)	±10%(K)				
470pF(471)	±10%(K)				
680pF(681)	±10%(K)				
1000pF(102)	±10%(K)		GRM188R61H102KA01D		
1500pF(152)	±10%(K)				
2200pF(222)	±10%(K)		GRM188R61H222KA01D		
3300pF(332)	±10%(K)				
4700pF(472)	±10%(K)		GRM188R61H472KA01D		
6800pF(682)	±10%(K)				
10000pF(103)	±10%(K)		GRM188R61H103KA01D		
15000pF(153)	±10%(K)				
22000pF(223)	±10%(K)		GRM188R61H223KA01D		
33000pF(333)	±10%(K)				
47000pF(473)	±10%(K)				
68000pF(683)	±10%(K)				
0.10μF(104)	±10%(K)			GRM188R61E104KA01D	GRM188R61C104KA01D
0.15μF(154)	±10%(K)				
0.22μF(224)	±10%(K)			GRM188R61E224KA88D	GRM188R61C224KA88D
0.33μF(334)	±10%(K)				
0.47μF(474)	±10%(K)			GRM188R61E474KA12D	GRM188R61C474KA93D
1.0μF(105)	±10%(K)			GRM188R61E105KA12D	GRM188R61C105KA93D
2.2μF(225)	±10%(K)				GRM188R61C225KE15D

LxW [mm]		1.6x0.8(18)<0603>		
Rated Volt. [Vdc]		10(1A)	6.3(0J)	4(0G)
Capacitance	Tolerance	Part Number		
0.15μF(154)	±10%(K)	GRM188R61A154KA01D		
0.22μF(224)	±10%(K)	GRM188R61A224KA01D		
0.33μF(334)	±10%(K)			
0.47μF(474)	±10%(K)	GRM188R61A474KA61D		
0.68μF(684)	±10%(K)			
2.2μF(225)	±10%(K)	GRM188R61A225KE34D		
4.7μF(475)	±10%(K)		GRM188R60J475KE19D	
10μF(106)	±20%(M)		GRM188R60J106ME47D	GRM188R60G106ME47D

The part number code is shown in () and Unit is shown in []. < >: EIA [inch] Code

: Please refer to X7R(R7) etc Characteristics.

● High Dielectric Constant Type X5R(R6) Characteristics

LxW [mm]		2.0x1.25(21)<0805>			
Rated Volt. [Vdc]		100(2A)	50(1H)	25(1E)	16(1C)
Capacitance	Tolerance	Part Number			
6800pF(682)	±10%(K)				
10000pF(103)	±10%(K)				
15000pF(153)	±10%(K)				
22000pF(223)	±10%(K)				
33000pF(333)	±10%(K)				
47000pF(473)	±10%(K)				
68000pF(683)	±10%(K)				
0.10μF(104)	±10%(K)				
0.15μF(154)	±10%(K)				
0.22μF(224)	±10%(K)				
0.33μF(334)	±10%(K)				GRM21BR61C334KA01L
0.47μF(474)	±10%(K)				GRM21BR61C474KA01L
0.68μF(684)	±10%(K)				
1.0μF(105)	±10%(K)			GRM216R61E105KA12D	GRM21BR61C105KA01L
2.2μF(225)	±10%(K)			GRM21BR61E225KA12L	GRM21BR61C225KA88L
				GRM219R61E225KA12D	GRM219R61C225KA88D
4.7μF(475)	±10%(K)			GRM21BR61E475KA12L	GRM21BR61C475KA88L
					GRM219R61C475KE15D
10μF(106)	±10%(K)				GRM21BR61C106KE15L

LxW [mm]		2.0x1.25(21)<0805>		
Rated Volt. [Vdc]		10(1A)	6.3(0J)	4(0G)
Capacitance	Tolerance	Part Number		
2.2μF(225)	±10%(K)	GRM21BR61A225KA01L		
4.7μF(475)	±10%(K)	GRM219R61A475KE34D		
10μF(106)	±10%(K)	GRM21BR61A106KE19L	GRM219R60J106KE19D	
		GRM219R61A106KE44D		
22μF(226)	±20%(M)		GRM21BR60J226ME39L	GRM219R60G226ME66D

The part number code is shown in () and Unit is shown in []. < >: EIA [inch] Code

□ : Please refer to X7R(R7) etc Characteristics.

△Note • This PDF catalog is downloaded from the website of Murata Manufacturing co., ltd. Therefore, it's specifications are subject to change or our products in it may be discontinued without advance notice. Please check with our sales representatives or product engineers before ordering.
• This PDF catalog has only typical specifications because there is no space for detailed specifications. Therefore, please approve our product specifications or transact the approval sheet for product specifications before ordering.

● High Dielectric Constant Type X5R(R6) Characteristics

LxW [mm]		3.2x1.6(31)<1206>			
Rated Volt. [Vdc]		100(2A)	50(1H)	25(1E)	16(1C)
Capacitance	Tolerance	Part Number			
15000pF(153)	±10%(K)				
22000pF(223)	±10%(K)				
33000pF(333)	±10%(K)				
47000pF(473)	±10%(K)				
68000pF(683)	±10%(K)				
0.10μF(104)	±10%(K)				
0.15μF(154)	±10%(K)				
0.22μF(224)	±10%(K)				
0.33μF(334)	±10%(K)				
0.47μF(474)	±10%(K)				
0.68μF(684)	±10%(K)				
1.0μF(105)	±10%(K)				
2.2μF(225)	±10%(K)		GRM31CR61H225KA88L	GRM316R61E225KA12D	
4.7μF(475)	±10%(K)			GRM31CR61E475KA88L	GRM31CR61C475KA01L
				GRM319R61E475KA12D	GRM319R61C475KA88D
10μF(106)	±10%(K)			GRM31CR61E106KA12L	GRM31CR61C106KA88L
					GRM319R61C106KE15D
22μF(226)	±20%(M)				GRM31CR61C226ME15L

LxW [mm]		3.2x1.6(31)<1206>		
Rated Volt. [Vdc]		10(1A)	6.3(0J)	4(0G)
Capacitance	Tolerance	Part Number		
10μF(106)	±10%(K)	GRM319R61A106KE19L		
22μF(226)	±20%(M)	GRM31CR61A226ME19L	GRM31CR60J226ME19L	
47μF(476)	±20%(M)		GRM31CR60J476ME19L	
100μF(107)	±20%(M)		GRM31CR60J107ME39L	GRM31CR60G107ME39L

LxW [mm]		3.2x2.5(32)<1210>			
Rated Volt. [Vdc]		100(2A)	50(1H)	35(YA)	25(1E)
Capacitance	Tolerance	Part Number			
0.68μF(684)	±10%(K)				
1.0μF(105)	±10%(K)				
2.2μF(225)	±10%(K)				
4.7μF(475)	±10%(K)				
10μF(106)	±10%(K)			GRM32ER6YA106KA12L	GRM32DR61E106KA12L
22μF(226)	±20%(M)				GRM32ER61E226ME15L

LxW [mm]		3.2x2.5(32)<1210>		
Rated Volt. [Vdc]		16(1C)	10(1A)	6.3(0J)
Capacitance	Tolerance	Part Number		
22μF(226)	±20%(M)			
47μF(476)	±20%(M)	GRM32ER61C476ME15L	GRM32ER61A476ME20L	

The part number code is shown in () and Unit is shown in []. < >: EIA [inch] Code

[] : Please refer to X7R(R7) etc Characteristics.

● High Dielectric Constant Type X5R(R6) Characteristics Low Profile

LxW [mm]		1.0x0.5(15)<0402>		
Rated Volt. [Vdc]		16(1C)	25(1E)	16(1C)
Capacitance	Tolerance	Part Number		
220pF(221)	±10%(K)			
330pF(331)	±10%(K)			
470pF(471)	±10%(K)			
680pF(681)	±10%(K)			
1000pF(102)	±10%(K)			
1500pF(152)	±10%(K)			
2200pF(222)	±10%(K)			
3300pF(332)	±10%(K)			
4700pF(472)	±10%(K)			
6800pF(682)	±10%(K)			
10000pF(103)	±10%(K)			

LxW [mm]		1.6x0.8(18)<0603>	
Rated Volt. [Vdc]		16(1C)	10(1A)
Capacitance	Tolerance	Part Number	
1.0μF(105)	±10%(K)	GRM185R61C105KE44D	GRM185R61A105KE36D

LxW [mm]		2.0x1.25(21)<0805>			
Rated Volt. [Vdc]		100(2A)	50(1H)	25(1E)	16(1C)
Capacitance	Tolerance	Part Number			
6800pF(682)	±10%(K)				
33000pF(333)	±10%(K)				
68000pF(683)	±10%(K)				
0.22μF(224)	±10%(K)				
0.33μF(334)	±10%(K)				
0.47μF(474)	±10%(K)				
0.68μF(684)	±10%(K)				
1.0μF(105)	±10%(K)			GRM216R61E105KA12D	
2.2μF(225)	±10%(K)			GRM219R61E225KA12D	GRM219R61C225KA88D
4.7μF(475)	±10%(K)				GRM219R61C475KE15D

LxW [mm]		2.0x1.25(21)<0805>		
Rated Volt. [Vdc]		10(1A)	6.3(0J)	4(0G)
Capacitance	Tolerance	Part Number		
4.7μF(475)	±10%(K)	GRM219R61A475KE34D		
10μF(106)	±10%(K)	GRM219R61A106KE44D	GRM219R60J106KE19D	
22μF(226)	±20%(M)			GRM219R60G226ME66D

The part number code is shown in () and Unit is shown in []. < >: EIA [inch] Code

□: Please refer to X7R(R7) etc Characteristics.

● High Dielectric Constant Type X5R(R6) Characteristics Low Profile

LxW [mm]		3.2x1.6(31)<1206>			
Rated Volt. [Vdc]		100(2A)	50(1H)	25(1E)	16(1C)
Capacitance	Tolerance	Part Number			
15000pF(153)	±10%(K)				
22000pF(223)	±10%(K)				
33000pF(333)	±10%(K)				
47000pF(473)	±10%(K)				
68000pF(683)	±10%(K)				
0.10μF(104)	±10%(K)				
0.15μF(154)	±10%(K)				
0.22μF(224)	±10%(K)				
0.33μF(334)	±10%(K)				
0.47μF(474)	±10%(K)				
0.68μF(684)	±10%(K)				
1.0μF(105)	±10%(K)				
2.2μF(225)	±10%(K)			GRM316R61E225KA12D	
4.7μF(475)	±10%(K)			GRM319R61E475KA12D	GRM319R61C475KA88D
10μF(106)	±10%(K)				GRM319R61C106KE15D

LxW [mm]		3.2x1.6(31)<1206>
Rated Volt. [Vdc]		10(1A)
Capacitance	Tolerance	Part Number
10μF(106)	±10%(K)	GRM319R61A106KE19D

LxW [mm]		3.2x2.5(32)<1210>		
Rated Volt. [Vdc]		100(2A)	50(1H)	25(1E)
Capacitance	Tolerance	Part Number		
0.68μF(684)	±10%(K)			
1.0μF(105)	±10%(K)			
10μF(106)	±10%(K)			GRM32DR61E106KA12L

The part number code is shown in () and Unit is shown in []. < >: EIA [inch] Code

□ : Please refer to X7R(R7) etc Characteristics.

Monolithic Ceramic Capacitors

Capacitor Array GNM Series

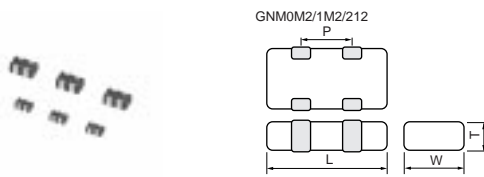

Part Number	Dimensions (mm)			
	L	W	T	P
GNM0M2	0.9 ±0.05	0.6 ±0.05	0.45 ±0.05	0.45 ±0.05
			0.5 +0.05/-0.10	
GNM1M2	1.37 ±0.15	1.0 ±0.15	0.6 ±0.1	0.64 ±0.05
			0.8 +0/-0.15	
GNM212	2.0 ±0.15	1.25 ±0.15	0.6 ±0.1	1.0 ±0.1
			0.85 ±0.1	

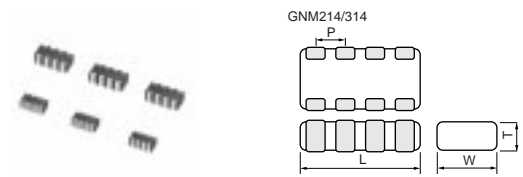

Part Number	Dimensions (mm)			
	L	W	T	P
GNM214	2.0 ±0.15	1.25 ±0.15	0.5 +0.05/-0.1	0.5 ±0.05
			0.6 ±0.1	
			0.85 ±0.1	
GNM314	3.2 ±0.15	1.6 ±0.15	0.8 ±0.1	0.8 ±0.1
			0.85 ±0.1	
			1.0 ±0.1	
			1.15 ±0.1	

● Temperature Compensating Type C0G(5C) Characteristics

LxW [mm]		1.37x1.0(1M)<0504>		2.0x1.25(21)<0805>		3.2x1.6(31)<1206>	
Rated Volt. [Vdc]		50(1H)		50(1H)		100(2A)	
Capacitance	Tolerance	Part Number					
10pF(100)	±10%(K)	GNM1M25C1H100KD01D	GNM2145C1H100KD01D	GNM3145C2A100KD01D	GNM3145C1H100KD01D		
15pF(150)	±10%(K)	GNM1M25C1H150KD01D	GNM2145C1H150KD01D	GNM3145C2A150KD01D	GNM3145C1H150KD01D		
22pF(220)	±10%(K)	GNM1M25C1H220KD01D	GNM2145C1H220KD01D	GNM3145C2A220KD01D	GNM3145C1H220KD01D		
33pF(330)	±10%(K)	GNM1M25C1H330KD01D	GNM2145C1H330KD01D	GNM3145C2A330KD01D	GNM3145C1H330KD01D		
47pF(470)	±10%(K)	GNM1M25C1H470KD01D	GNM2145C1H470KD01D	GNM3145C2A470KD01D	GNM3145C1H470KD01D		
68pF(680)	±10%(K)	GNM1M25C1H680KD01D	GNM2145C1H680KD01D	GNM3145C2A680KD01D	GNM3145C1H680KD01D		
100pF(101)	±10%(K)	GNM1M25C1H101KD01D	GNM2145C1H101KD01D	GNM3145C2A101KD01D	GNM3145C1H101KD01D		
150pF(151)	±10%(K)	GNM1M25C1H151KD01D	GNM2145C1H151KD01D	GNM3145C2A151KD01D	GNM3145C1H151KD01D		
220pF(221)	±10%(K)	GNM1M25C1H221KD01D	GNM2145C1H221KD01D		GNM3145C1H221KD01D		
330pF(331)	±10%(K)				GNM3145C1H331KD01D		

The part number code is shown in () and Unit is shown in []. < >: EIA [inch] Code

● High Dielectric Constant Type X7R(R7)/X7S(C7) Characteristics

LxW [mm]		1.37x1.0(1M)<0504>			
Number of Elements		2(2)			
Rated Volt. [Vdc]		50(1H)		10(1A)	
Capacitance	Tolerance	Part Number			
1000pF(102)	±20%(M)	GNM1M2R71H102MA01D			
2200pF(222)	±20%(M)		GNM1M2R71E222MA01D		
4700pF(472)	±20%(M)		GNM1M2R71E472MA01D		
10000pF(103)	±20%(M)		GNM1M2R71E103MA01D		
22000pF(223)	±20%(M)			GNM1M2R71C223MA01D	GNM1M2R71A223MA01D
47000pF(473)	±20%(M)			GNM1M2R71C473MA01D	GNM1M2R71A473MA01D
0.10μF(104)	±20%(M)			GNM1M2R71C104MA01D	GNM1M2C71A104MA01D

LxW [mm]		2.0x1.25(21)<0805>		
Number of Elements		4(4)		
Rated Volt. [Vdc]		50(1H)		16(1C)
Capacitance	Tolerance	Part Number		
470pF(471)	±20%(M)	GNM214R71H471MA01D		
1000pF(102)	±20%(M)	GNM214R71H102MA01D		
2200pF(222)	±20%(M)		GNM214R71E222MA01D	
4700pF(472)	±20%(M)		GNM214R71E472MA01D	
10000pF(103)	±20%(M)		GNM214R71E103MA01D	
22000pF(223)	±20%(M)			GNM214R71C223MA01D
47000pF(473)	±20%(M)			GNM214R71C473MA01D
0.10μF(104)	±20%(M)			GNM214R71C104MA01D

LxW [mm]		3.2x1.6(31)<1206>			
Number of Elements		4(4)			
Rated Volt. [Vdc]		50(1H)		6.3(0J)	
Capacitance	Tolerance	Part Number			
47000pF(473)	±20%(M)	GNM314R71H473MA11D		GNM314R71C473MA01L	
0.10μF(104)	±20%(M)	GNM314R71H104MA11D	GNM314R71E104MA11D	GNM314R71C104MA01L	
1.0μF(105)	±20%(M)				GNM314R70J105MA01L

The part number code is shown in () and Unit is shown in []. < >: EIA [inch] Code

● High Dielectric Constant Type X5R(R6) Characteristics

LxW [mm]		0.9x0.6(0M)<0302>			
Number of Elements		2(2)			
Rated Volt. [Vdc]		16(1C)	10(1A)	6.3(0J)	4(0G)
Capacitance	Tolerance	Part Number			
10000pF(103)	±20%(M)	GNM0M2R61C103ME18D	GNM0M2R61A103ME17D	GNM0M2R60J103ME17D	
22000pF(223)	±20%(M)	GNM0M2R61C223ME18D	GNM0M2R61A223ME17D	GNM0M2R60J223ME17D	
47000pF(473)	±20%(M)	GNM0M2R61C473ME18D	GNM0M2R61A473ME17D	GNM0M2R60J473ME17D	
0.10μF(104)	±20%(M)	GNM0M2R61C104ME18D	GNM0M2R61A104ME17D	GNM0M2R60J104ME17D	
1.0μF(105)	±20%(M)				GNM0M2R60G105ME17D

LxW [mm]		1.37x1.0(1M)<0504>		
Number of Elements		2(2)		
Rated Volt. [Vdc]		50(1H)	25(1E)	16(1C)
Capacitance	Tolerance	Part Number		
1000pF(102)	±20%(M)	GNM1M2R61H102MA01D		
2200pF(222)	±20%(M)		GNM1M2R61E222MA01D	
4700pF(472)	±20%(M)		GNM1M2R61E472MA01D	
10000pF(103)	±20%(M)		GNM1M2R61E103MA01D	
22000pF(223)	±20%(M)			GNM1M2R61C223MA01D
47000pF(473)	±20%(M)			GNM1M2R61C473MA01D
0.22μF(224)	±20%(M)			GNM1M2R61C224ME18D
1.0μF(105)	±20%(M)			GNM1M2R61C105ME18D

LxW [mm]		1.37x1.0(1M)<0504>	
Number of Elements		2(2)	
Rated Volt. [Vdc]		10(1A)	6.3(0J)
Capacitance	Tolerance	Part Number	
22000pF(223)	±20%(M)	GNM1M2R61A223MA01D	
47000pF(473)	±20%(M)	GNM1M2R61A473MA01D	
0.10μF(104)	±20%(M)	GNM1M2R61A104MA01D	
1.0μF(105)	±20%(M)	GNM1M2R61A105ME17D	GNM1M2R60J105ME12D
2.2μF(225)	±20%(M)	GNM1M2R61A225ME18D	GNM1M2R60J225ME18D

LxW [mm]		2.0x1.25(21)<0805>		
Number of Elements		2(2)		
Rated Volt. [Vdc]		16(1C)	10(1A)	6.3(0J)
Capacitance	Tolerance	Part Number		
0.47μF(474)	±20%(M)	GNM212R61C474MA16D		
1.0μF(105)	±20%(M)	GNM212R61C105MA16D	GNM212R61A105MA13D	
2.2μF(225)	±20%(M)		GNM212R61A225ME16D	GNM212R60J225ME16D

The part number code is shown in () and Unit is shown in []. < >: EIA [inch] Code

● High Dielectric Constant Type X5R(R6) Characteristics

LxW [mm]		2.0x1.25(21)<0805>	
Number of Elements		4(4)	
Rated Volt. [Vdc]		10(1A)	6.3(0J)
Capacitance	Tolerance	Part Number	
1.0μF(105)	±20%(M)	GNM214R61A105ME17D	GNM214R60J105ME17D
2.2μF(225)	±20%(M)		GNM214R60J225ME18D

LxW [mm]		3.2x1.6(31)<1206>	
Number of Elements		4(4)	
Rated Volt. [Vdc]		16(1C)	10(1A)
Capacitance	Tolerance	Part Number	
1.0μF(105)	±20%(M)	GNM314R61C105MA15D	GNM314R61A105MA13D

The part number code is shown in () and Unit is shown in []. < >: EIA [inch] Code

● High Dielectric Constant Type X7R(R7) Characteristics Low Profile

LxW [mm]		1.37x1.0(1M)<0504>	2.0x1.25(21)<0805>
Number of Elements		2(2)	4(4)
Rated Volt. [Vdc]		16(1C)	16(1C)
Capacitance	Tolerance	Part Number	
0.10μF(104)	±20%(M)	GNM1M2R71C104MAA1D	GNM214R71C104MAA1D

The part number code is shown in () and Unit is shown in []. < >: EIA [inch] Code

● High Dielectric Constant Type X5R(R6) Characteristics Low Profile

LxW [mm]		1.37x1.0(1M)<0504>	
Number of Elements		2(2)	
Rated Volt. [Vdc]		16(1C)	10(1A)
Capacitance	Tolerance	Part Number	
1.0μF(105)	±20%(M)	GNM1M2R61C105MEA2D	GNM1M2R61A105MEA4D

The part number code is shown in () and Unit is shown in []. < >: EIA [inch] Code

Monolithic Ceramic Capacitors

Low ESL LLL Series

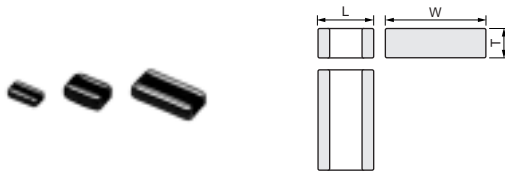

Part Number	Dimensions (mm)		
	L	W	T
LLL153	0.5 ±0.05	1.0 ±0.05	0.3 ±0.05
LLL185	0.8 ±0.1	1.6 ±0.1	0.6 max.
LLL215	1.25 ±0.1	2.0 ±0.1	0.5 +0/-0.15
LLL216			0.6 ±0.1
LLL219			0.85 ±0.1
LLL315			0.5 +0/-0.15
LLL317	1.6 ±0.15	3.2 ±0.15	0.7 ±0.1
LLL31M			1.15 ±0.1

△Note • This PDF catalog is downloaded from the website of Murata Manufacturing co., ltd. Therefore, it's specifications are subject to change or our products in it may be discontinued without advance notice. Please check with our sales representatives or product engineers before ordering.
• This PDF catalog has only typical specifications because there is no space for detailed specifications. Therefore, please approve our product specifications or transact the approval sheet for product specifications before ordering.

● Reversed Geometry Low ESL Type X7R(R7)/X7S(C7)/X6S(C8) Characteristics

LxW [mm]		0.5x1.0(15)<0204>	
Rated Volt. [Vdc]		6.3(0J)	4(0G)
Capacitance	Tolerance	Part Number	
0.10μF(104)	±20%(M)	LLL153C80J104ME01E	
0.22μF(224)	±20%(M)	LLL153C80J224ME14E	
0.47μF(474)	±20%(M)	LLL153C70G474ME17E	

LLL153 Series 4V/0.47μF(L: 0.5+0.07/-0.03mm)

LxW [mm]		0.8x1.6(18)<0306>			
Rated Volt. [Vdc]		50(1H)	25(1E)	16(1C)	10(1A)
Capacitance	Tolerance	Part Number			
2200pF(222)	±20%(M)	LLL185R71H222MA01L			
4700pF(472)	±20%(M)	LLL185R71H472MA01L			
10000pF(103)	±20%(M)		LLL185R71E103MA01L		
22000pF(223)	±20%(M)		LLL185R71E223MA01L		
47000pF(473)	±20%(M)		LLL185R71C473MA01L		
0.10μF(104)	±20%(M)				LLL185R71A104MA01L
0.22μF(224)	±20%(M)				LLL185R71A224MA01L

LxW [mm]		0.8x1.6(18)<0306>	
Rated Volt. [Vdc]		4(0G)	
Capacitance	Tolerance	Part Number	
0.47μF(474)	±20%(M)	LLL185C70G474MA01L	
1.0μF(105)	±20%(M)	LLL185C70G105ME02L	
2.2μF(225)	±20%(M)	LLL185C70G225ME01L	

LxW [mm]		1.25x2.0(21)<0508>			
Rated Volt. [Vdc]		50(1H)	25(1E)	16(1C)	10(1A)
Capacitance	Tolerance	Part Number			
10000pF(103)	±20%(M)	LLL216R71H103MA01L			
22000pF(223)	±20%(M)	LLL216R71H223MA01L			
47000pF(473)	±20%(M)		LLL216R71E473MA01L		
0.10μF(104)	±20%(M)		LLL216R71E104MA01L		
0.22μF(224)	±20%(M)			LLL219R71C224MA01L	LLL216R71A224MA01L
0.47μF(474)	±20%(M)				LLL219R71A474MA01L
1.0μF(105)	±20%(M)				LLL219R71A105MA01L

LxW [mm]		1.25x2.0(21)<0508>	
Rated Volt. [Vdc]		4(0G)	
Capacitance	Tolerance	Part Number	
2.2μF(225)	±20%(M)	LLL219C70G225MA01L	

The part number code is shown in () and Unit is shown in []. < >: EIA [inch] Code

● Reversed Geometry Low ESL Type X7R(R7)/X5R(R6) Characteristics

LxW [mm]		1.6x3.2(31)<0612>			
Rated Volt. [Vdc]		50(1H)	25(1E)	16(1C)	10(1A)
Capacitance	Tolerance	Part Number			
10000pF(103)	±20%(M)	LLL317R71H103MA01L			
22000pF(223)	±20%(M)	LLL317R71H223MA01L			
47000pF(473)	±20%(M)	LLL317R71H473MA01L			
0.10μF(104)	±20%(M)	LLL31MR71H104MA01L	LLL317R71E104MA01L		
0.22μF(224)	±20%(M)		LLL31MR71E224MA01L	LLL317R71C224MA01L	
0.47μF(474)	±20%(M)		LLL31MR71E474MA01L	LLL317R71C474MA01L	
1.0μF(105)	±20%(M)			LLL31MR71C105MA01L	LLL317R71A105MA01L
2.2μF(225)	±20%(M)				LLL31MR71A225MA01L

LxW [mm]		1.6x3.2(31)<0612>
Rated Volt. [Vdc]		6.3(0J)
Capacitance	Tolerance	Part Number
2.2μF(225)	±20%(M)	LLL317R70J225MA01L
4.7μF(475)	±20%(M)	LLL31MR70J475MA01L
10μF(106)	±20%(M)	LLL31MR60J106ME01L

The part number code is shown in () and Unit is shown in []. < >: EIA [inch] Code

● Reversed Geometry Low ESL Type X7R(R7)/X7S(C7) Characteristics Low Profile

LxW [mm]		0.8x1.6(18)<0306>			
Rated Volt. [Vdc]		25(1E)	16(1C)	10(1A)	4(0G)
Capacitance	Tolerance	Part Number			
10000pF(103)	±20%(M)	LLL185R71E103MA11L			
22000pF(223)	±20%(M)		LLL185R71C223MA11L		
47000pF(473)	±20%(M)		LLL185R71C473MA11L		
0.10μF(104)	±20%(M)			LLL185R71A104MA11L	
0.22μF(224)	±20%(M)				LLL185C70G224MA11L

LxW [mm]		1.25x2.0(21)<0508>			
Rated Volt. [Vdc]		50(1H)	25(1E)	16(1C)	10(1A)
Capacitance	Tolerance	Part Number			
10000pF(103)	±20%(M)	LLL215R71H103MA11L			
22000pF(223)	±20%(M)		LLL215R71E223MA11L		
47000pF(473)	±20%(M)			LLL215R71C473MA11L	
0.10μF(104)	±20%(M)			LLL215R71C104MA11L	
0.22μF(224)	±20%(M)				LLL215R71A224MA11L

LxW [mm]		1.25x2.0(21)<0508>	
Rated Volt. [Vdc]		6.3(0J)	4(0G)
Capacitance	Tolerance	Part Number	
0.47μF(474)	±20%(M)	LLL215R70J474MA11L	
1.0μF(105)	±20%(M)		LLL215C70G105MA11L

LxW [mm]		1.6x3.2(31)<0612>			
Rated Volt. [Vdc]		50(1H)	25(1E)	16(1C)	10(1A)
Capacitance	Tolerance	Part Number			
10000pF(103)	±20%(M)	LLL315R71H103MA11L			
22000pF(223)	±20%(M)	LLL315R71H223MA11L			
47000pF(473)	±20%(M)		LLL315R71E473MA11L		
0.10μF(104)	±20%(M)		LLL315R71E104MA11L		
0.22μF(224)	±20%(M)			LLL315R71C224MA11L	
0.47μF(474)	±20%(M)				LLL315R71A474MA11L

The part number code is shown in () and Unit is shown in []. < >: EIA [inch] Code

△Note • This PDF catalog is downloaded from the website of Murata Manufacturing co., ltd. Therefore, it's specifications are subject to change or our products in it may be discontinued without advance notice. Please check with our sales representatives or product engineers before ordering.
• This PDF catalog has only typical specifications because there is no space for detailed specifications. Therefore, please approve our product specifications or transact the approval sheet for product specifications before ordering.

Monolithic Ceramic Capacitors

Low ESL LLA Series

1
Capacitors

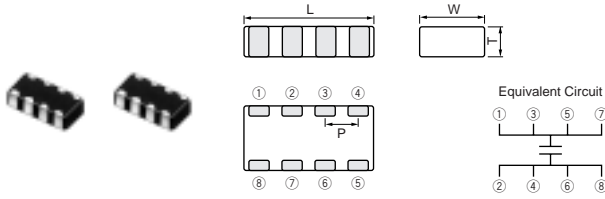

Part Number	Dimensions (mm)			
	L	W	T	P
LLA185	1.6 ±0.1	0.8 ±0.1	0.5 +0.05/-0.1	0.4 ±0.1
LLA215	2.0 ±0.1	1.25 ±0.1	0.5 +0.05/-0.1	0.5 ±0.05
LLA219	2.0 ±0.1	1.25 ±0.1	0.85 ±0.1	0.5 ±0.05
LLA315	3.2 ±0.15	1.6 ±0.15	0.5 +0.05/-0.1	0.8 ±0.1
LLA319	3.2 ±0.15	1.6 ±0.15	0.85 ±0.1	0.8 ±0.1
LLA31M	3.2 ±0.15	1.6 ±0.15	1.15 ±0.1	0.8 ±0.1

● Eight Terminals Low ESL Type X7R(R7)/X7S(C7) Characteristics

LxW [mm]		1.6x0.8(18)<0603>
Rated Volt. [Vdc]		4(0G)
Capacitance	Tolerance	Part Number
0.10μF(104)	±20%(M)	LLA185C70G104MA01L
0.22μF(224)	±20%(M)	LLA185C70G224MA01L
0.47μF(474)	±20%(M)	LLA185C70G474MA01L
1.0μF(105)	±20%(M)	LLA185C70G105ME01L
2.2μF(225)	±20%(M)	LLA185C70G225ME16L

LxW [mm]		2.0x1.25(21)<0805>			
Rated Volt. [Vdc]		25(1E)	16(1C)	10(1A)	6.3(0J)
Capacitance	Tolerance	Part Number			
10000pF(103)	±20%(M)	LLA219R71E103MA01L			
22000pF(223)	±20%(M)	LLA219R71E223MA01L			
47000pF(473)	±20%(M)	LLA219R71E473MA01L			
0.10μF(104)	±20%(M)		LLA219R71C104MA01L		
0.22μF(224)	±20%(M)		LLA219R71C224MA01L		
0.47μF(474)	±20%(M)			LLA219R71A474MA01L	
1.0μF(105)	±20%(M)				LLA219R70J105MA01L

LxW [mm]		2.0x1.25(21)<0805>
Rated Volt. [Vdc]		4(0G)
Capacitance	Tolerance	Part Number
2.2μF(225)	±20%(M)	LLA219C70G225MA01L
4.7μF(475)	±20%(M)	LLA219C70G475ME01L

LxW [mm]		3.2x1.6(31)<1206>		
Rated Volt. [Vdc]		16(1C)	10(1A)	4(0G)
Capacitance	Tolerance	Part Number		
0.10μF(104)	±20%(M)	LLA319R71C104MA01L		
0.22μF(224)	±20%(M)	LLA319R71C224MA01L		
0.47μF(474)	±20%(M)	LLA319R71C474MA01L		
1.0μF(105)	±20%(M)	LLA31MR71C105MA01L	LLA319R71A105MA01L	
2.2μF(225)	±20%(M)		LLA31MR71A225MA01L	LLA319R70G225MA01L

The part number code is shown in () and Unit is shown in []. < >: EIA [inch] Code

⚠Note • This PDF catalog is downloaded from the website of Murata Manufacturing co., Ltd. Therefore, it's specifications are subject to change or our products in it may be discontinued without advance notice. Please check with our sales representatives or product engineers before ordering.
• This PDF catalog has only typical specifications because there is no space for detailed specifications. Therefore, please approve our product specifications or transact the approval sheet for product specifications before ordering.

● Eight Terminals Low ESL Type X7R(R7)/X7S(C7) Characteristics Low Profile

LxW [mm]		2.0x1.25(21)<0805>			
Rated Volt. [Vdc]		25(1E)	16(1C)	10(1A)	6.3(0J)
Capacitance	Tolerance	Part Number			
10000pF(103)	±20%(M)	LLA215R71E103MA14L			
22000pF(223)	±20%(M)	LLA215R71E223MA14L			
47000pF(473)	±20%(M)		LLA215R71C473MA14L		
0.10μF(104)	±20%(M)		LLA215R71C104MA14L		
0.22μF(224)	±20%(M)			LLA215R71A224MA14L	
0.47μF(474)	±20%(M)				LLA215R70J474MA14L

LxW [mm]		2.0x1.25(21)<0805>	
Rated Volt. [Vdc]		4(0G)	
Capacitance	Tolerance	Part Number	
1.0μF(105)	±20%(M)	LLA215C70G105MA14L	
2.2μF(225)	±20%(M)	LLA215C70G225ME11L	
4.7μF(475)	±20%(M)	LLA215C70G475ME19L	

LxW [mm]		3.2x1.6(31)<1206>		
Rated Volt. [Vdc]		16(1C)	10(1A)	6.3(0J)
Capacitance	Tolerance	Part Number		
0.22μF(224)	±20%(M)	LLA315R71C224MA14L		
0.47μF(474)	±20%(M)		LLA315R71A474MA14L	
1.0μF(105)	±20%(M)			LLA315R70J105MA14L
2.2μF(225)	±20%(M)			LLA315R70J225MA14L

The part number code is shown in () and Unit is shown in []. < >: EIA [inch] Code

Monolithic Ceramic Capacitors

Low ESL LLM Series

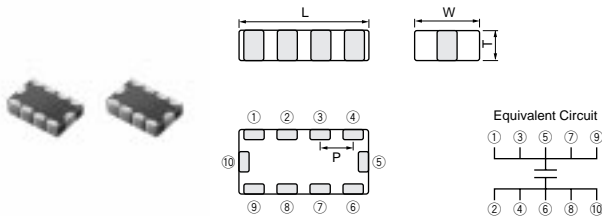

Part Number	Dimensions (mm)			
	L	W	T	P
LLM215	2.0 ±0.1	1.25 ±0.1	0.5 +0.05/-0.1	0.5 ±0.05
LLM315	3.2 ±0.15	1.6 ±0.15	0.5 +0.05/-0.1	0.8 ±0.1

△Note • This PDF catalog is downloaded from the website of Murata Manufacturing co., ltd. Therefore, it's specifications are subject to change or our products in it may be discontinued without advance notice. Please check with our sales representatives or product engineers before ordering.
• This PDF catalog has only typical specifications because there is no space for detailed specifications. Therefore, please approve our product specifications or transact the approval sheet for product specifications before ordering.

● Ten Terminals Low ESL Type X7R(R7)/X7S(C7) Characteristics Low Profile

LxW [mm]		2.0x1.25(21)<0805>			
Rated Volt. [Vdc]		25(1E)	16(1C)	6.3(0J)	4(0G)
Capacitance	Tolerance	Part Number			
10000pF(103)	±20%(M)	LLM215R71E103MA11L			
22000pF(223)	±20%(M)	LLM215R71E223MA11L			
47000pF(473)	±20%(M)		LLM215R71C473MA11L		
0.10μF(104)	±20%(M)		LLM215R71C104MA11L		
0.22μF(224)	±20%(M)			LLM215R70J224MA11L	
0.47μF(474)	±20%(M)			LLM215R70J474MA11L	
1.0μF(105)	±20%(M)				LLM215C70G105MA11L
2.2μF(225)	±20%(M)				LLM215C70G225ME11L

LxW [mm]		3.2x1.6(31)<1206>		
Rated Volt. [Vdc]		16(1C)	10(1A)	6.3(0J)
Capacitance	Tolerance	Part Number		
0.10μF(104)	±20%(M)	LLM315R71C104MA11L		
0.22μF(224)	±20%(M)	LLM315R71C224MA11L		
0.47μF(474)	±20%(M)		LLM315R71A474MA11L	
2.2μF(225)	±20%(M)			LLM315R70J225MA11L

The part number code is shown in () and Unit is shown in []. < >: EIA [inch] Code

Monolithic Ceramic Capacitors

Low Dissipation Type GJM Series

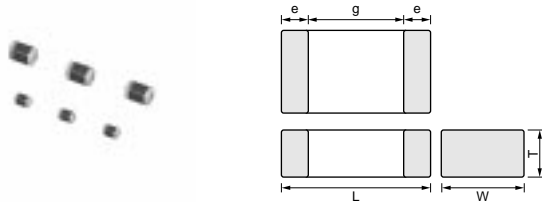

Part Number	Dimensions (mm)				
	L	W	T	e	g min.
GJM03	0.6 ±0.03	0.3 ±0.03	0.3 ±0.03	0.1 to 0.2	0.2
GJM15	1.0 ±0.05	0.5 ±0.05	0.5 ±0.05	0.15 to 0.3	0.4

● Temperature Compensating Type C0G(5C)/C0H(6C) Characteristics

LxW [mm]		0.6x0.3(03)<0201>	1.0x0.5(15)<0402>
Rated Volt. [Vdc]		25(1E)	50(1H)
Capacitance	Tolerance	Part Number	
0.1pF(R10)	±0.05pF(W)		GJM1555C1HR10WB01D
	±0.1pF(B)		GJM1555C1HR10BB01D
0.2pF(R20)	±0.05pF(W)	GJM0335C1ER20WB01D	GJM1555C1HR20WB01D
	±0.1pF(B)	GJM0335C1ER20BB01D	GJM1555C1HR20BB01D
0.3pF(R30)	±0.05pF(W)	GJM0335C1ER30WB01D	GJM1555C1HR30WB01D
	±0.1pF(B)	GJM0335C1ER30BB01D	GJM1555C1HR30BB01D
0.4pF(R40)	±0.05pF(W)	GJM0335C1ER40WB01D	GJM1555C1HR40WB01D
	±0.1pF(B)	GJM0335C1ER40BB01D	GJM1555C1HR40BB01D
0.5pF(R50)	±0.05pF(W)	GJM0335C1ER50WB01D	GJM1555C1HR50WB01D
	±0.1pF(B)	GJM0335C1ER50BB01D	GJM1555C1HR50BB01D
0.6pF(R60)	±0.05pF(W)	GJM0335C1ER60WB01D	GJM1555C1HR60WB01D
	±0.1pF(B)	GJM0335C1ER60BB01D	GJM1555C1HR60BB01D

The part number code is shown in () and Unit is shown in []. < >: EIA [inch] Code

⚠Note • This PDF catalog is downloaded from the website of Murata Manufacturing co., Ltd. Therefore, it's specifications are subject to change or our products in it may be discontinued without advance notice. Please check with our sales representatives or product engineers before ordering.
• This PDF catalog has only typical specifications because there is no space for detailed specifications. Therefore, please approve our product specifications or transact the approval sheet for product specifications before ordering.

● Temperature Compensating Type C0G(5C) Characteristics

LxW [mm]		0.6x0.3(03)<0201>	1.0x0.5(15)<0402>
Rated Volt. [Vdc]		25(1E)	50(1H)
Capacitance	Tolerance	Part Number	
0.7pF(R70)	±0.05pF(W)	GJM0335C1ER70WB01D	GJM1555C1HR70WB01D
	±0.1pF(B)	GJM0335C1ER70BB01D	GJM1555C1HR70BB01D
0.8pF(R80)	±0.05pF(W)	GJM0335C1ER80WB01D	GJM1555C1HR80WB01D
	±0.1pF(B)	GJM0335C1ER80BB01D	GJM1555C1HR80BB01D
0.9pF(R90)	±0.05pF(W)	GJM0335C1ER90WB01D	GJM1555C1HR90WB01D
	±0.1pF(B)	GJM0335C1ER90BB01D	GJM1555C1HR90BB01D
1.0pF(1R0)	±0.05pF(W)	GJM0335C1E1R0WB01D	GJM1555C1H1R0WB01D
	±0.1pF(B)	GJM0335C1E1R0BB01D	GJM1555C1H1R0BB01D
	±0.25pF(C)	GJM0335C1E1R0CB01D	GJM1555C1H1R0CB01D
1.1pF(1R1)	±0.05pF(W)	GJM0335C1E1R1WB01D	GJM1555C1H1R1WB01D
	±0.1pF(B)	GJM0335C1E1R1BB01D	GJM1555C1H1R1BB01D
	±0.25pF(C)	GJM0335C1E1R1CB01D	GJM1555C1H1R1CB01D
1.2pF(1R2)	±0.05pF(W)	GJM0335C1E1R2WB01D	GJM1555C1H1R2WB01D
	±0.1pF(B)	GJM0335C1E1R2BB01D	GJM1555C1H1R2BB01D
	±0.25pF(C)	GJM0335C1E1R2CB01D	GJM1555C1H1R2CB01D
1.3pF(1R3)	±0.05pF(W)	GJM0335C1E1R3WB01D	GJM1555C1H1R3WB01D
	±0.1pF(B)	GJM0335C1E1R3BB01D	GJM1555C1H1R3BB01D
	±0.25pF(C)	GJM0335C1E1R3CB01D	GJM1555C1H1R3CB01D
1.4pF(1R4)	±0.05pF(W)	GJM0335C1E1R4WB01D	GJM1555C1H1R4WB01D
	±0.1pF(B)	GJM0335C1E1R4BB01D	GJM1555C1H1R4BB01D
	±0.25pF(C)	GJM0335C1E1R4CB01D	GJM1555C1H1R4CB01D
1.5pF(1R5)	±0.05pF(W)	GJM0335C1E1R5WB01D	GJM1555C1H1R5WB01D
	±0.1pF(B)	GJM0335C1E1R5BB01D	GJM1555C1H1R5BB01D
	±0.25pF(C)	GJM0335C1E1R5CB01D	GJM1555C1H1R5CB01D
1.6pF(1R6)	±0.05pF(W)	GJM0335C1E1R6WB01D	GJM1555C1H1R6WB01D
	±0.1pF(B)	GJM0335C1E1R6BB01D	GJM1555C1H1R6BB01D
	±0.25pF(C)	GJM0335C1E1R6CB01D	GJM1555C1H1R6CB01D
1.7pF(1R7)	±0.05pF(W)	GJM0335C1E1R7WB01D	GJM1555C1H1R7WB01D
	±0.1pF(B)	GJM0335C1E1R7BB01D	GJM1555C1H1R7BB01D
	±0.25pF(C)	GJM0335C1E1R7CB01D	GJM1555C1H1R7CB01D
1.8pF(1R8)	±0.05pF(W)	GJM0335C1E1R8WB01D	GJM1555C1H1R8WB01D
	±0.1pF(B)	GJM0335C1E1R8BB01D	GJM1555C1H1R8BB01D
	±0.25pF(C)	GJM0335C1E1R8CB01D	GJM1555C1H1R8CB01D
1.9pF(1R9)	±0.05pF(W)	GJM0335C1E1R9WB01D	GJM1555C1H1R9WB01D
	±0.1pF(B)	GJM0335C1E1R9BB01D	GJM1555C1H1R9BB01D
	±0.25pF(C)	GJM0335C1E1R9CB01D	GJM1555C1H1R9CB01D
2.0pF(2R0)	±0.05pF(W)	GJM0335C1E2R0WB01D	GJM1555C1H2R0WB01D
	±0.1pF(B)	GJM0335C1E2R0BB01D	GJM1555C1H2R0BB01D
	±0.25pF(C)	GJM0335C1E2R0CB01D	GJM1555C1H2R0CB01D
2.1pF(2R1)	±0.05pF(W)	GJM0335C1E2R1WB01D	GJM1555C1H2R1WB01D
	±0.1pF(B)	GJM0335C1E2R1BB01D	GJM1555C1H2R1BB01D
	±0.25pF(C)	GJM0335C1E2R1CB01D	GJM1555C1H2R1CB01D
2.2pF(2R2)	±0.05pF(W)	GJM0335C1E2R2WB01D	GJM1555C1H2R2WB01D
	±0.1pF(B)	GJM0335C1E2R2BB01D	GJM1555C1H2R2BB01D
	±0.25pF(C)	GJM0335C1E2R2CB01D	GJM1555C1H2R2CB01D
2.3pF(2R3)	±0.05pF(W)	GJM0335C1E2R3WB01D	GJM1555C1H2R3WB01D
	±0.1pF(B)	GJM0335C1E2R3BB01D	GJM1555C1H2R3BB01D
	±0.25pF(C)	GJM0335C1E2R3CB01D	GJM1555C1H2R3CB01D
2.4pF(2R4)	±0.05pF(W)	GJM0335C1E2R4WB01D	GJM1555C1H2R4WB01D
	±0.1pF(B)	GJM0335C1E2R4BB01D	GJM1555C1H2R4BB01D
	±0.25pF(C)	GJM0335C1E2R4CB01D	GJM1555C1H2R4CB01D

The part number code is shown in () and Unit is shown in []. < >: EIA [inch] Code

△Note • This PDF catalog is downloaded from the website of Murata Manufacturing co., Ltd. Therefore, it's specifications are subject to change or our products in it may be discontinued without advance notice. Please check with our sales representatives or product engineers before ordering.
• This PDF catalog has only typical specifications because there is no space for detailed specifications. Therefore, please approve our product specifications or transact the approval sheet for product specifications before ordering.

● Temperature Compensating Type C0G(5C) Characteristics

LxW [mm]		0.6x0.3(03)<0201>	1.0x0.5(15)<0402>
Rated Volt. [Vdc]		25(1E)	50(1H)
Capacitance	Tolerance	Part Number	
2.5pF(2R5)	±0.05pF(W)	GJM0335C1E2R5WB01D	GJM1555C1H2R5WB01D
	±0.1pF(B)	GJM0335C1E2R5BB01D	GJM1555C1H2R5BB01D
	±0.25pF(C)	GJM0335C1E2R5CB01D	GJM1555C1H2R5CB01D
2.6pF(2R6)	±0.05pF(W)	GJM0335C1E2R6WB01D	GJM1555C1H2R6WB01D
	±0.1pF(B)	GJM0335C1E2R6BB01D	GJM1555C1H2R6BB01D
	±0.25pF(C)	GJM0335C1E2R6CB01D	GJM1555C1H2R6CB01D
2.7pF(2R7)	±0.05pF(W)	GJM0335C1E2R7WB01D	GJM1555C1H2R7WB01D
	±0.1pF(B)	GJM0335C1E2R7BB01D	GJM1555C1H2R7BB01D
	±0.25pF(C)	GJM0335C1E2R7CB01D	GJM1555C1H2R7CB01D
2.8pF(2R8)	±0.05pF(W)	GJM0335C1E2R8WB01D	GJM1555C1H2R8WB01D
	±0.1pF(B)	GJM0335C1E2R8BB01D	GJM1555C1H2R8BB01D
	±0.25pF(C)	GJM0335C1E2R8CB01D	GJM1555C1H2R8CB01D
2.9pF(2R9)	±0.05pF(W)	GJM0335C1E2R9WB01D	GJM1555C1H2R9WB01D
	±0.1pF(B)	GJM0335C1E2R9BB01D	GJM1555C1H2R9BB01D
	±0.25pF(C)	GJM0335C1E2R9CB01D	GJM1555C1H2R9CB01D
3.0pF(3R0)	±0.05pF(W)	GJM0335C1E3R0WB01D	GJM1555C1H3R0WB01D
	±0.1pF(B)	GJM0335C1E3R0BB01D	GJM1555C1H3R0BB01D
	±0.25pF(C)	GJM0335C1E3R0CB01D	GJM1555C1H3R0CB01D
3.1pF(3R1)	±0.05pF(W)	GJM0335C1E3R1WB01D	GJM1555C1H3R1WB01D
	±0.1pF(B)	GJM0335C1E3R1BB01D	GJM1555C1H3R1BB01D
	±0.25pF(C)	GJM0335C1E3R1CB01D	GJM1555C1H3R1CB01D
3.2pF(3R2)	±0.05pF(W)	GJM0335C1E3R2WB01D	GJM1555C1H3R2WB01D
	±0.1pF(B)	GJM0335C1E3R2BB01D	GJM1555C1H3R2BB01D
	±0.25pF(C)	GJM0335C1E3R2CB01D	GJM1555C1H3R2CB01D
3.3pF(3R3)	±0.05pF(W)	GJM0335C1E3R3WB01D	GJM1555C1H3R3WB01D
	±0.1pF(B)	GJM0335C1E3R3BB01D	GJM1555C1H3R3BB01D
	±0.25pF(C)	GJM0335C1E3R3CB01D	GJM1555C1H3R3CB01D
3.4pF(3R4)	±0.05pF(W)	GJM0335C1E3R4WB01D	GJM1555C1H3R4WB01D
	±0.1pF(B)	GJM0335C1E3R4BB01D	GJM1555C1H3R4BB01D
	±0.25pF(C)	GJM0335C1E3R4CB01D	GJM1555C1H3R4CB01D
3.5pF(3R5)	±0.05pF(W)	GJM0335C1E3R5WB01D	GJM1555C1H3R5WB01D
	±0.1pF(B)	GJM0335C1E3R5BB01D	GJM1555C1H3R5BB01D
	±0.25pF(C)	GJM0335C1E3R5CB01D	GJM1555C1H3R5CB01D
3.6pF(3R6)	±0.05pF(W)	GJM0335C1E3R6WB01D	GJM1555C1H3R6WB01D
	±0.1pF(B)	GJM0335C1E3R6BB01D	GJM1555C1H3R6BB01D
	±0.25pF(C)	GJM0335C1E3R6CB01D	GJM1555C1H3R6CB01D
3.7pF(3R7)	±0.05pF(W)	GJM0335C1E3R7WB01D	GJM1555C1H3R7WB01D
	±0.1pF(B)	GJM0335C1E3R7BB01D	GJM1555C1H3R7BB01D
	±0.25pF(C)	GJM0335C1E3R7CB01D	GJM1555C1H3R7CB01D
3.8pF(3R8)	±0.05pF(W)	GJM0335C1E3R8WB01D	GJM1555C1H3R8WB01D
	±0.1pF(B)	GJM0335C1E3R8BB01D	GJM1555C1H3R8BB01D
	±0.25pF(C)	GJM0335C1E3R8CB01D	GJM1555C1H3R8CB01D
3.9pF(3R9)	±0.05pF(W)	GJM0335C1E3R9WB01D	GJM1555C1H3R9WB01D
	±0.1pF(B)	GJM0335C1E3R9BB01D	GJM1555C1H3R9BB01D
	±0.25pF(C)	GJM0335C1E3R9CB01D	GJM1555C1H3R9CB01D
4.0pF(4R0)	±0.05pF(W)	GJM0335C1E4R0WB01D	GJM1555C1H4R0WB01D
	±0.1pF(B)	GJM0335C1E4R0BB01D	GJM1555C1H4R0BB01D
	±0.25pF(C)	GJM0335C1E4R0CB01D	GJM1555C1H4R0CB01D
4.1pF(4R1)	±0.05pF(W)	GJM0335C1E4R1WB01D	GJM1555C1H4R1WB01D
	±0.1pF(B)	GJM0335C1E4R1BB01D	GJM1555C1H4R1BB01D
	±0.25pF(C)	GJM0335C1E4R1CB01D	GJM1555C1H4R1CB01D

The part number code is shown in () and Unit is shown in []. < >: EIA [inch] Code

● Temperature Compensating Type C0G(5C) Characteristics

LxW [mm]		0.6x0.3(03)<0201>	1.0x0.5(15)<0402>
Rated Volt. [Vdc]		25(1E)	50(1H)
Capacitance	Tolerance	Part Number	
4.2pF(4R2)	±0.05pF(W)	GJM0335C1E4R2WB01D	GJM1555C1H4R2WB01D
	±0.1pF(B)	GJM0335C1E4R2BB01D	GJM1555C1H4R2BB01D
	±0.25pF(C)	GJM0335C1E4R2CB01D	GJM1555C1H4R2CB01D
4.3pF(4R3)	±0.05pF(W)	GJM0335C1E4R3WB01D	GJM1555C1H4R3WB01D
	±0.1pF(B)	GJM0335C1E4R3BB01D	GJM1555C1H4R3BB01D
	±0.25pF(C)	GJM0335C1E4R3CB01D	GJM1555C1H4R3CB01D
4.4pF(4R4)	±0.05pF(W)	GJM0335C1E4R4WB01D	GJM1555C1H4R4WB01D
	±0.1pF(B)	GJM0335C1E4R4BB01D	GJM1555C1H4R4BB01D
	±0.25pF(C)	GJM0335C1E4R4CB01D	GJM1555C1H4R4CB01D
4.5pF(4R5)	±0.05pF(W)	GJM0335C1E4R5WB01D	GJM1555C1H4R5WB01D
	±0.1pF(B)	GJM0335C1E4R5BB01D	GJM1555C1H4R5BB01D
	±0.25pF(C)	GJM0335C1E4R5CB01D	GJM1555C1H4R5CB01D
4.6pF(4R6)	±0.05pF(W)	GJM0335C1E4R6WB01D	GJM1555C1H4R6WB01D
	±0.1pF(B)	GJM0335C1E4R6BB01D	GJM1555C1H4R6BB01D
	±0.25pF(C)	GJM0335C1E4R6CB01D	GJM1555C1H4R6CB01D
4.7pF(4R7)	±0.05pF(W)	GJM0335C1E4R7WB01D	GJM1555C1H4R7WB01D
	±0.1pF(B)	GJM0335C1E4R7BB01D	GJM1555C1H4R7BB01D
	±0.25pF(C)	GJM0335C1E4R7CB01D	GJM1555C1H4R7CB01D
4.8pF(4R8)	±0.05pF(W)	GJM0335C1E4R8WB01D	GJM1555C1H4R8WB01D
	±0.1pF(B)	GJM0335C1E4R8BB01D	GJM1555C1H4R8BB01D
	±0.25pF(C)	GJM0335C1E4R8CB01D	GJM1555C1H4R8CB01D
4.9pF(4R9)	±0.05pF(W)	GJM0335C1E4R9WB01D	GJM1555C1H4R9WB01D
	±0.1pF(B)	GJM0335C1E4R9BB01D	GJM1555C1H4R9BB01D
	±0.25pF(C)	GJM0335C1E4R9CB01D	GJM1555C1H4R9CB01D
5.0pF(5R0)	±0.05pF(W)	GJM0335C1E5R0WB01D	GJM1555C1H5R0WB01D
	±0.1pF(B)	GJM0335C1E5R0BB01D	GJM1555C1H5R0BB01D
	±0.25pF(C)	GJM0335C1E5R0CB01D	GJM1555C1H5R0CB01D
5.1pF(5R1)	±0.05pF(W)	GJM0335C1E5R1WB01D	GJM1555C1H5R1WB01D
	±0.1pF(B)	GJM0335C1E5R1BB01D	GJM1555C1H5R1BB01D
	±0.25pF(C)	GJM0335C1E5R1CB01D	GJM1555C1H5R1CB01D
	±0.5pF(D)	GJM0335C1E5R1DB01D	GJM1555C1H5R1DB01D
5.2pF(5R2)	±0.05pF(W)	GJM0335C1E5R2WB01D	GJM1555C1H5R2WB01D
	±0.1pF(B)	GJM0335C1E5R2BB01D	GJM1555C1H5R2BB01D
	±0.25pF(C)	GJM0335C1E5R2CB01D	GJM1555C1H5R2CB01D
	±0.5pF(D)	GJM0335C1E5R2DB01D	GJM1555C1H5R2DB01D
5.3pF(5R3)	±0.05pF(W)	GJM0335C1E5R3WB01D	GJM1555C1H5R3WB01D
	±0.1pF(B)	GJM0335C1E5R3BB01D	GJM1555C1H5R3BB01D
	±0.25pF(C)	GJM0335C1E5R3CB01D	GJM1555C1H5R3CB01D
	±0.5pF(D)	GJM0335C1E5R3DB01D	GJM1555C1H5R3DB01D
5.4pF(5R4)	±0.05pF(W)	GJM0335C1E5R4WB01D	GJM1555C1H5R4WB01D
	±0.1pF(B)	GJM0335C1E5R4BB01D	GJM1555C1H5R4BB01D
	±0.25pF(C)	GJM0335C1E5R4CB01D	GJM1555C1H5R4CB01D
	±0.5pF(D)	GJM0335C1E5R4DB01D	GJM1555C1H5R4DB01D
5.5pF(5R5)	±0.05pF(W)	GJM0335C1E5R5WB01D	GJM1555C1H5R5WB01D
	±0.1pF(B)	GJM0335C1E5R5BB01D	GJM1555C1H5R5BB01D
	±0.25pF(C)	GJM0335C1E5R5CB01D	GJM1555C1H5R5CB01D
	±0.5pF(D)	GJM0335C1E5R5DB01D	GJM1555C1H5R5DB01D
5.6pF(5R6)	±0.05pF(W)	GJM0335C1E5R6WB01D	GJM1555C1H5R6WB01D
	±0.1pF(B)	GJM0335C1E5R6BB01D	GJM1555C1H5R6BB01D
	±0.25pF(C)	GJM0335C1E5R6CB01D	GJM1555C1H5R6CB01D
	±0.5pF(D)	GJM0335C1E5R6DB01D	GJM1555C1H5R6DB01D

The part number code is shown in () and Unit is shown in []. < >: EIA [inch] Code

△Note • This PDF catalog is downloaded from the website of Murata Manufacturing co., Ltd. Therefore, it's specifications are subject to change or our products in it may be discontinued without advance notice. Please check with our sales representatives or product engineers before ordering.
 • This PDF catalog has only typical specifications because there is no space for detailed specifications. Therefore, please approve our product specifications or transact the approval sheet for product specifications before ordering.

● Temperature Compensating Type C0G(5C)/C0H(6C) Characteristics

LxW [mm]		0.6x0.3(03)<0201>	1.0x0.5(15)<0402>
Rated Volt. [Vdc]		25(1E)	50(1H)
Capacitance	Tolerance	Part Number	
5.7pF(5R7)	±0.05pF(W)	GJM0335C1E5R7WB01D	GJM1555C1H5R7WB01D
	±0.1pF(B)	GJM0335C1E5R7BB01D	GJM1555C1H5R7BB01D
	±0.25pF(C)	GJM0335C1E5R7CB01D	GJM1555C1H5R7CB01D
	±0.5pF(D)	GJM0335C1E5R7DB01D	GJM1555C1H5R7DB01D
5.8pF(5R8)	±0.05pF(W)	GJM0335C1E5R8WB01D	GJM1555C1H5R8WB01D
	±0.1pF(B)	GJM0335C1E5R8BB01D	GJM1555C1H5R8BB01D
	±0.25pF(C)	GJM0335C1E5R8CB01D	GJM1555C1H5R8CB01D
	±0.5pF(D)	GJM0335C1E5R8DB01D	GJM1555C1H5R8DB01D
5.9pF(5R9)	±0.05pF(W)	GJM0335C1E5R9WB01D	GJM1555C1H5R9WB01D
	±0.1pF(B)	GJM0335C1E5R9BB01D	GJM1555C1H5R9BB01D
	±0.25pF(C)	GJM0335C1E5R9CB01D	GJM1555C1H5R9CB01D
	±0.5pF(D)	GJM0335C1E5R9DB01D	GJM1555C1H5R9DB01D
6.0pF(6R0)	±0.05pF(W)	GJM0335C1E6R0WB01D	GJM1555C1H6R0WB01D
	±0.1pF(B)	GJM0335C1E6R0BB01D	GJM1555C1H6R0BB01D
	±0.25pF(C)	GJM0335C1E6R0CB01D	GJM1555C1H6R0CB01D
	±0.5pF(D)	GJM0335C1E6R0DB01D	GJM1555C1H6R0DB01D
6.1pF(6R1)	±0.05pF(W)	GJM0335C1E6R1WB01D	GJM1555C1H6R1WB01D
	±0.1pF(B)	GJM0335C1E6R1BB01D	GJM1555C1H6R1BB01D
	±0.25pF(C)	GJM0335C1E6R1CB01D	GJM1555C1H6R1CB01D
	±0.5pF(D)	GJM0335C1E6R1DB01D	GJM1555C1H6R1DB01D
6.2pF(6R2)	±0.05pF(W)	GJM0335C1E6R2WB01D	GJM1555C1H6R2WB01D
	±0.1pF(B)	GJM0335C1E6R2BB01D	GJM1555C1H6R2BB01D
	±0.25pF(C)	GJM0335C1E6R2CB01D	GJM1555C1H6R2CB01D
	±0.5pF(D)	GJM0335C1E6R2DB01D	GJM1555C1H6R2DB01D
6.3pF(6R3)	±0.05pF(W)	GJM0335C1E6R3WB01D	GJM1555C1H6R3WB01D
	±0.1pF(B)	GJM0335C1E6R3BB01D	GJM1555C1H6R3BB01D
	±0.25pF(C)	GJM0335C1E6R3CB01D	GJM1555C1H6R3CB01D
	±0.5pF(D)	GJM0335C1E6R3DB01D	GJM1555C1H6R3DB01D
6.4pF(6R4)	±0.05pF(W)	GJM0335C1E6R4WB01D	GJM1555C1H6R4WB01D
	±0.1pF(B)	GJM0335C1E6R4BB01D	GJM1555C1H6R4BB01D
	±0.25pF(C)	GJM0335C1E6R4CB01D	GJM1555C1H6R4CB01D
	±0.5pF(D)	GJM0335C1E6R4DB01D	GJM1555C1H6R4DB01D
6.5pF(6R5)	±0.05pF(W)	GJM0335C1E6R5WB01D	GJM1555C1H6R5WB01D
	±0.1pF(B)	GJM0335C1E6R5BB01D	GJM1555C1H6R5BB01D
	±0.25pF(C)	GJM0335C1E6R5CB01D	GJM1555C1H6R5CB01D
	±0.5pF(D)	GJM0335C1E6R5DB01D	GJM1555C1H6R5DB01D
6.6pF(6R6)	±0.05pF(W)	GJM0335C1E6R6WB01D	GJM1555C1H6R6WB01D
	±0.1pF(B)	GJM0335C1E6R6BB01D	GJM1555C1H6R6BB01D
	±0.25pF(C)	GJM0335C1E6R6CB01D	GJM1555C1H6R6CB01D
	±0.5pF(D)	GJM0335C1E6R6DB01D	GJM1555C1H6R6DB01D
6.7pF(6R7)	±0.05pF(W)	GJM0335C1E6R7WB01D	GJM1555C1H6R7WB01D
	±0.1pF(B)	GJM0335C1E6R7BB01D	GJM1555C1H6R7BB01D
	±0.25pF(C)	GJM0335C1E6R7CB01D	GJM1555C1H6R7CB01D
	±0.5pF(D)	GJM0335C1E6R7DB01D	GJM1555C1H6R7DB01D
6.8pF(6R8)	±0.05pF(W)	GJM0335C1E6R8WB01D	GJM1555C1H6R8WB01D
	±0.1pF(B)	GJM0335C1E6R8BB01D	GJM1555C1H6R8BB01D
	±0.25pF(C)	GJM0335C1E6R8CB01D	GJM1555C1H6R8CB01D
	±0.5pF(D)	GJM0335C1E6R8DB01D	GJM1555C1H6R8DB01D
6.9pF(6R9)	±0.05pF(W)	GJM0336C1E6R9WB01D	GJM1555C1H6R9WB01D
	±0.1pF(B)	GJM0336C1E6R9BB01D	GJM1555C1H6R9BB01D
	±0.25pF(C)	GJM0336C1E6R9CB01D	GJM1555C1H6R9CB01D
	±0.5pF(D)	GJM0336C1E6R9DB01D	GJM1555C1H6R9DB01D

The part number code is shown in () and Unit is shown in []. < >: EIA [inch] Code

⚠Note • This PDF catalog is downloaded from the website of Murata Manufacturing co., Ltd. Therefore, it's specifications are subject to change or our products in it may be discontinued without advance notice. Please check with our sales representatives or product engineers before ordering.
• This PDF catalog has only typical specifications because there is no space for detailed specifications. Therefore, please approve our product specifications or transact the approval sheet for product specifications before ordering.

● Temperature Compensating Type C0G(5C)/C0H(6C) Characteristics

LxW [mm]		0.6x0.3(03)<0201>	1.0x0.5(15)<0402>
Rated Volt. [Vdc]		25(1E)	50(1H)
Capacitance	Tolerance	Part Number	
7.0pF(7R0)	±0.05pF(W)	GJM0336C1E7R0WB01D	GJM1555C1H7R0WB01D
	±0.1pF(B)	GJM0336C1E7R0BB01D	GJM1555C1H7R0BB01D
	±0.25pF(C)	GJM0336C1E7R0CB01D	GJM1555C1H7R0CB01D
	±0.5pF(D)	GJM0336C1E7R0DB01D	GJM1555C1H7R0DB01D
7.1pF(7R1)	±0.05pF(W)	GJM0336C1E7R1WB01D	GJM1555C1H7R1WB01D
	±0.1pF(B)	GJM0336C1E7R1BB01D	GJM1555C1H7R1BB01D
	±0.25pF(C)	GJM0336C1E7R1CB01D	GJM1555C1H7R1CB01D
	±0.5pF(D)	GJM0336C1E7R1DB01D	GJM1555C1H7R1DB01D
7.2pF(7R2)	±0.05pF(W)	GJM0336C1E7R2WB01D	GJM1555C1H7R2WB01D
	±0.1pF(B)	GJM0336C1E7R2BB01D	GJM1555C1H7R2BB01D
	±0.25pF(C)	GJM0336C1E7R2CB01D	GJM1555C1H7R2CB01D
	±0.5pF(D)	GJM0336C1E7R2DB01D	GJM1555C1H7R2DB01D
7.3pF(7R3)	±0.05pF(W)	GJM0336C1E7R3WB01D	GJM1555C1H7R3WB01D
	±0.1pF(B)	GJM0336C1E7R3BB01D	GJM1555C1H7R3BB01D
	±0.25pF(C)	GJM0336C1E7R3CB01D	GJM1555C1H7R3CB01D
	±0.5pF(D)	GJM0336C1E7R3DB01D	GJM1555C1H7R3DB01D
7.4pF(7R4)	±0.05pF(W)	GJM0336C1E7R4WB01D	GJM1555C1H7R4WB01D
	±0.1pF(B)	GJM0336C1E7R4BB01D	GJM1555C1H7R4BB01D
	±0.25pF(C)	GJM0336C1E7R4CB01D	GJM1555C1H7R4CB01D
	±0.5pF(D)	GJM0336C1E7R4DB01D	GJM1555C1H7R4DB01D
7.5pF(7R5)	±0.05pF(W)	GJM0336C1E7R5WB01D	GJM1555C1H7R5WB01D
	±0.1pF(B)	GJM0336C1E7R5BB01D	GJM1555C1H7R5BB01D
	±0.25pF(C)	GJM0336C1E7R5CB01D	GJM1555C1H7R5CB01D
	±0.5pF(D)	GJM0336C1E7R5DB01D	GJM1555C1H7R5DB01D
7.6pF(7R6)	±0.05pF(W)	GJM0336C1E7R6WB01D	GJM1555C1H7R6WB01D
	±0.1pF(B)	GJM0336C1E7R6BB01D	GJM1555C1H7R6BB01D
	±0.25pF(C)	GJM0336C1E7R6CB01D	GJM1555C1H7R6CB01D
	±0.5pF(D)	GJM0336C1E7R6DB01D	GJM1555C1H7R6DB01D
7.7pF(7R7)	±0.05pF(W)	GJM0336C1E7R7WB01D	GJM1555C1H7R7WB01D
	±0.1pF(B)	GJM0336C1E7R7BB01D	GJM1555C1H7R7BB01D
	±0.25pF(C)	GJM0336C1E7R7CB01D	GJM1555C1H7R7CB01D
	±0.5pF(D)	GJM0336C1E7R7DB01D	GJM1555C1H7R7DB01D
7.8pF(7R8)	±0.05pF(W)	GJM0336C1E7R8WB01D	GJM1555C1H7R8WB01D
	±0.1pF(B)	GJM0336C1E7R8BB01D	GJM1555C1H7R8BB01D
	±0.25pF(C)	GJM0336C1E7R8CB01D	GJM1555C1H7R8CB01D
	±0.5pF(D)	GJM0336C1E7R8DB01D	GJM1555C1H7R8DB01D
7.9pF(7R9)	±0.05pF(W)	GJM0336C1E7R9WB01D	GJM1555C1H7R9WB01D
	±0.1pF(B)	GJM0336C1E7R9BB01D	GJM1555C1H7R9BB01D
	±0.25pF(C)	GJM0336C1E7R9CB01D	GJM1555C1H7R9CB01D
	±0.5pF(D)	GJM0336C1E7R9DB01D	GJM1555C1H7R9DB01D
8.0pF(8R0)	±0.05pF(W)	GJM0336C1E8R0WB01D	GJM1555C1H8R0WB01D
	±0.1pF(B)	GJM0336C1E8R0BB01D	GJM1555C1H8R0BB01D
	±0.25pF(C)	GJM0336C1E8R0CB01D	GJM1555C1H8R0CB01D
	±0.5pF(D)	GJM0336C1E8R0DB01D	GJM1555C1H8R0DB01D
8.1pF(8R1)	±0.05pF(W)	GJM0336C1E8R1WB01D	GJM1555C1H8R1WB01D
	±0.1pF(B)	GJM0336C1E8R1BB01D	GJM1555C1H8R1BB01D
	±0.25pF(C)	GJM0336C1E8R1CB01D	GJM1555C1H8R1CB01D
	±0.5pF(D)	GJM0336C1E8R1DB01D	GJM1555C1H8R1DB01D
8.2pF(8R2)	±0.05pF(W)	GJM0336C1E8R2WB01D	GJM1555C1H8R2WB01D
	±0.1pF(B)	GJM0336C1E8R2BB01D	GJM1555C1H8R2BB01D
	±0.25pF(C)	GJM0336C1E8R2CB01D	GJM1555C1H8R2CB01D
	±0.5pF(D)	GJM0336C1E8R2DB01D	GJM1555C1H8R2DB01D

The part number code is shown in () and Unit is shown in []. <>: EIA [inch] Code

△Note • This PDF catalog is downloaded from the website of Murata Manufacturing co., Ltd. Therefore, it's specifications are subject to change or our products in it may be discontinued without advance notice. Please check with our sales representatives or product engineers before ordering.
• This PDF catalog has only typical specifications because there is no space for detailed specifications. Therefore, please approve our product specifications or transact the approval sheet for product specifications before ordering.

● Temperature Compensating Type C0G(5C)/C0H(6C) Characteristics

LxW [mm]		0.6x0.3(03)<0201>	1.0x0.5(15)<0402>
Rated Volt. [Vdc]		25(1E)	50(1H)
Capacitance	Tolerance	Part Number	
8.3pF(8R3)	±0.05pF(W)	GJM0336C1E8R3WB01D	GJM1555C1H8R3WB01D
	±0.1pF(B)	GJM0336C1E8R3BB01D	GJM1555C1H8R3BB01D
	±0.25pF(C)	GJM0336C1E8R3CB01D	GJM1555C1H8R3CB01D
	±0.5pF(D)	GJM0336C1E8R3DB01D	GJM1555C1H8R3DB01D
8.4pF(8R4)	±0.05pF(W)	GJM0336C1E8R4WB01D	GJM1555C1H8R4WB01D
	±0.1pF(B)	GJM0336C1E8R4BB01D	GJM1555C1H8R4BB01D
	±0.25pF(C)	GJM0336C1E8R4CB01D	GJM1555C1H8R4CB01D
	±0.5pF(D)	GJM0336C1E8R4DB01D	GJM1555C1H8R4DB01D
8.5pF(8R5)	±0.05pF(W)	GJM0336C1E8R5WB01D	GJM1555C1H8R5WB01D
	±0.1pF(B)	GJM0336C1E8R5BB01D	GJM1555C1H8R5BB01D
	±0.25pF(C)	GJM0336C1E8R5CB01D	GJM1555C1H8R5CB01D
	±0.5pF(D)	GJM0336C1E8R5DB01D	GJM1555C1H8R5DB01D
8.6pF(8R6)	±0.05pF(W)	GJM0336C1E8R6WB01D	GJM1555C1H8R6WB01D
	±0.1pF(B)	GJM0336C1E8R6BB01D	GJM1555C1H8R6BB01D
	±0.25pF(C)	GJM0336C1E8R6CB01D	GJM1555C1H8R6CB01D
	±0.5pF(D)	GJM0336C1E8R6DB01D	GJM1555C1H8R6DB01D
8.7pF(8R7)	±0.05pF(W)	GJM0336C1E8R7WB01D	GJM1555C1H8R7WB01D
	±0.1pF(B)	GJM0336C1E8R7BB01D	GJM1555C1H8R7BB01D
	±0.25pF(C)	GJM0336C1E8R7CB01D	GJM1555C1H8R7CB01D
	±0.5pF(D)	GJM0336C1E8R7DB01D	GJM1555C1H8R7DB01D
8.8pF(8R8)	±0.05pF(W)	GJM0336C1E8R8WB01D	GJM1555C1H8R8WB01D
	±0.1pF(B)	GJM0336C1E8R8BB01D	GJM1555C1H8R8BB01D
	±0.25pF(C)	GJM0336C1E8R8CB01D	GJM1555C1H8R8CB01D
	±0.5pF(D)	GJM0336C1E8R8DB01D	GJM1555C1H8R8DB01D
8.9pF(8R9)	±0.05pF(W)	GJM0336C1E8R9WB01D	GJM1555C1H8R9WB01D
	±0.1pF(B)	GJM0336C1E8R9BB01D	GJM1555C1H8R9BB01D
	±0.25pF(C)	GJM0336C1E8R9CB01D	GJM1555C1H8R9CB01D
	±0.5pF(D)	GJM0336C1E8R9DB01D	GJM1555C1H8R9DB01D
9.0pF(9R0)	±0.05pF(W)	GJM0336C1E9R0WB01D	GJM1555C1H9R0WB01D
	±0.1pF(B)	GJM0336C1E9R0BB01D	GJM1555C1H9R0BB01D
	±0.25pF(C)	GJM0336C1E9R0CB01D	GJM1555C1H9R0CB01D
	±0.5pF(D)	GJM0336C1E9R0DB01D	GJM1555C1H9R0DB01D
9.1pF(9R1)	±0.05pF(W)	GJM0336C1E9R1WB01D	GJM1555C1H9R1WB01D
	±0.1pF(B)	GJM0336C1E9R1BB01D	GJM1555C1H9R1BB01D
	±0.25pF(C)	GJM0336C1E9R1CB01D	GJM1555C1H9R1CB01D
	±0.5pF(D)	GJM0336C1E9R1DB01D	GJM1555C1H9R1DB01D
9.2pF(9R2)	±0.05pF(W)	GJM0336C1E9R2WB01D	GJM1555C1H9R2WB01D
	±0.1pF(B)	GJM0336C1E9R2BB01D	GJM1555C1H9R2BB01D
	±0.25pF(C)	GJM0336C1E9R2CB01D	GJM1555C1H9R2CB01D
	±0.5pF(D)	GJM0336C1E9R2DB01D	GJM1555C1H9R2DB01D
9.3pF(9R3)	±0.05pF(W)	GJM0336C1E9R3WB01D	GJM1555C1H9R3WB01D
	±0.1pF(B)	GJM0336C1E9R3BB01D	GJM1555C1H9R3BB01D
	±0.25pF(C)	GJM0336C1E9R3CB01D	GJM1555C1H9R3CB01D
	±0.5pF(D)	GJM0336C1E9R3DB01D	GJM1555C1H9R3DB01D
9.4pF(9R4)	±0.05pF(W)	GJM0336C1E9R4WB01D	GJM1555C1H9R4WB01D
	±0.1pF(B)	GJM0336C1E9R4BB01D	GJM1555C1H9R4BB01D
	±0.25pF(C)	GJM0336C1E9R4CB01D	GJM1555C1H9R4CB01D
	±0.5pF(D)	GJM0336C1E9R4DB01D	GJM1555C1H9R4DB01D
9.5pF(9R5)	±0.05pF(W)	GJM0336C1E9R5WB01D	GJM1555C1H9R5WB01D
	±0.1pF(B)	GJM0336C1E9R5BB01D	GJM1555C1H9R5BB01D
	±0.25pF(C)	GJM0336C1E9R5CB01D	GJM1555C1H9R5CB01D
	±0.5pF(D)	GJM0336C1E9R5DB01D	GJM1555C1H9R5DB01D

The part number code is shown in () and Unit is shown in []. < >: EIA [inch] Code

● Temperature Compensating Type C0G(5C)/C0H(6C) Characteristics

LxW [mm]		0.6x0.3(03)<0201>		1.0x0.5(15)<0402>	
Rated Volt. [Vdc]		25(1E)		50(1H)	
Capacitance	Tolerance	Part Number			
9.6pF(9R6)	±0.05pF(W)	GJM0336C1E9R6WB01D	GJM1555C1H9R6WB01D		
	±0.1pF(B)	GJM0336C1E9R6BB01D	GJM1555C1H9R6BB01D		
	±0.25pF(C)	GJM0336C1E9R6CB01D	GJM1555C1H9R6CB01D		
	±0.5pF(D)	GJM0336C1E9R6DB01D	GJM1555C1H9R6DB01D		
9.7pF(9R7)	±0.05pF(W)	GJM0336C1E9R7WB01D	GJM1555C1H9R7WB01D		
	±0.1pF(B)	GJM0336C1E9R7BB01D	GJM1555C1H9R7BB01D		
	±0.25pF(C)	GJM0336C1E9R7CB01D	GJM1555C1H9R7CB01D		
	±0.5pF(D)	GJM0336C1E9R7DB01D	GJM1555C1H9R7DB01D		
9.8pF(9R8)	±0.05pF(W)	GJM0336C1E9R8WB01D	GJM1555C1H9R8WB01D		
	±0.1pF(B)	GJM0336C1E9R8BB01D	GJM1555C1H9R8BB01D		
	±0.25pF(C)	GJM0336C1E9R8CB01D	GJM1555C1H9R8CB01D		
	±0.5pF(D)	GJM0336C1E9R8DB01D	GJM1555C1H9R8DB01D		
9.9pF(9R9)	±0.05pF(W)	GJM0336C1E9R9WB01D	GJM1555C1H9R9WB01D		
	±0.1pF(B)	GJM0336C1E9R9BB01D	GJM1555C1H9R9BB01D		
	±0.25pF(C)	GJM0336C1E9R9CB01D	GJM1555C1H9R9CB01D		
	±0.5pF(D)	GJM0336C1E9R9DB01D	GJM1555C1H9R9DB01D		

LxW [mm]		0.6x0.3(03)<0201>		1.0x0.5(15)<0402>	
Rated Volt. [Vdc]		25(1E)		6.3(0J) 50(1H)	
Capacitance	Tolerance	Part Number			
10pF(100)	±2%(G)	GJM0336C1E100GB01D	GJM1555C1H100GB01D		
	±5%(J)	GJM0336C1E100JB01D	GJM1555C1H100JB01D		
11pF(110)	±2%(G)	GJM0336C1E110GB01D	GJM1555C1H110GB01D		
	±5%(J)	GJM0336C1E110JB01D	GJM1555C1H110JB01D		
12pF(120)	±2%(G)	GJM0336C1E120GB01D	GJM1555C1H120GB01D		
	±5%(J)	GJM0336C1E120JB01D	GJM1555C1H120JB01D		
13pF(130)	±2%(G)	GJM0336C1E130GB01D	GJM1555C1H130GB01D		
	±5%(J)	GJM0336C1E130JB01D	GJM1555C1H130JB01D		
15pF(150)	±2%(G)	GJM0336C1E150GB01D	GJM1555C1H150GB01D		
	±5%(J)	GJM0336C1E150JB01D	GJM1555C1H150JB01D		
16pF(160)	±2%(G)	GJM0336C1E160GB01D	GJM1555C1H160GB01D		
	±5%(J)	GJM0336C1E160JB01D	GJM1555C1H160JB01D		
18pF(180)	±2%(G)	GJM0336C1E180GB01D	GJM1555C1H180GB01D		
	±5%(J)	GJM0336C1E180JB01D	GJM1555C1H180JB01D		
20pF(200)	±2%(G)	GJM0336C1E200GB01D	GJM1555C1H200GB01D		
	±5%(J)	GJM0336C1E200JB01D	GJM1555C1H200JB01D		
22pF(220)	±2%(G)		GJM0335C0J220GB01D		
	±5%(J)		GJM0335C0J220JB01D		
24pF(240)	±2%(G)		GJM0335C0J240GB01D		
	±5%(J)		GJM0335C0J240JB01D		
27pF(270)	±2%(G)		GJM0335C0J270GB01D		
	±5%(J)		GJM0335C0J270JB01D		
30pF(300)	±2%(G)		GJM0335C0J300GB01D		
	±5%(J)		GJM0335C0J300JB01D		
33pF(330)	±2%(G)		GJM0335C0J330GB01D		
	±5%(J)		GJM0335C0J330JB01D		

The part number code is shown in () and Unit is shown in []. < >: EIA [inch] Code

△Note • This PDF catalog is downloaded from the website of Murata Manufacturing co., Ltd. Therefore, it's specifications are subject to change or our products in it may be discontinued without advance notice. Please check with our sales representatives or product engineers before ordering.
• This PDF catalog has only typical specifications because there is no space for detailed specifications. Therefore, please approve our product specifications or transact the approval sheet for product specifications before ordering.

Monolithic Ceramic Capacitors

Monolithic Microchip GMA Series

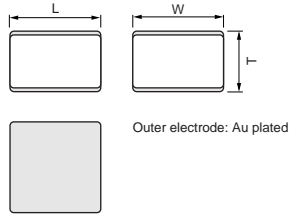

Part Number	Dimensions (mm)		
	L	W	T
GMA0D3	0.38 ±0.05	0.38 ±0.05	0.3 ±0.05
GMA05X	0.5 ±0.05	0.5 ±0.05	0.35 ±0.05
GMA085	0.8 ±0.05	0.8 ±0.05	0.5 ±0.1

● High Dielectric Constant Type X7R(R7)/X5R(R6) Characteristics

LxW [mm]	0.38x0.38(0D)<015015>	
Rated Volt. [Vdc]	10(1A)	
Capacitance	Tolerance	Part Number
10000pF(103)	±20%(M)	GMA0D3R71A103MA01T

LxW [mm]	0.5x0.5(05)<0202>			
Rated Volt. [Vdc]	100(2A)	25(1E)	10(1A)	6.3(0J)
Capacitance	Tolerance	Part Number		
100pF(101)	±20%(M)	GMA05XR72A101MA01T		
150pF(151)	±20%(M)	GMA05XR72A151MA01T		
220pF(221)	±20%(M)	GMA05XR72A221MA01T		
330pF(331)	±20%(M)	GMA05XR72A331MA01T		
470pF(471)	±20%(M)	GMA05XR72A471MA01T		
680pF(681)	±20%(M)	GMA05XR72A681MA01T		
1000pF(102)	±20%(M)	GMA05XR72A102MA01T		
1500pF(152)	±20%(M)		GMA05XR71E152MA11T	
2200pF(222)	±20%(M)		GMA05XR71E222MA11T	
3300pF(332)	±20%(M)		GMA05XR71E332MA11T	
4700pF(472)	±20%(M)		GMA05XR71E472MA11T	
6800pF(682)	±20%(M)			GMA05XR71A682MA01T
10000pF(103)	±20%(M)			GMA05XR71A103MA01T
15000pF(153)	±20%(M)			GMA05XR71A153MA01T
22000pF(223)	±20%(M)			GMA05XR71A223MA01T
33000pF(333)	±20%(M)			
47000pF(473)	±20%(M)			
68000pF(683)	±20%(M)			
0.10μF(104)	±20%(M)			GMA05XR60J104ME12T

LxW [mm]	0.8x0.8(08)<0303>			
Rated Volt. [Vdc]	100(2A)	25(1E)	10(1A)	6.3(0J)
Capacitance	Tolerance	Part Number		
1500pF(152)	±20%(M)	GMA085R72A152MA01T		
2200pF(222)	±20%(M)	GMA085R72A222MA01T		
3300pF(332)	±20%(M)	GMA085R72A332MA01T		
4700pF(472)	±20%(M)	GMA085R72A472MA01T		
6800pF(682)	±20%(M)	GMA085R72A682MA01T		
10000pF(103)	±20%(M)		GMA085R71E103MA11T	
15000pF(153)	±20%(M)		GMA085R71E153MA11T	
22000pF(223)	±20%(M)		GMA085R71E223MA11T	
33000pF(333)	±20%(M)			GMA085R71A333MA01T
47000pF(473)	±20%(M)			GMA085R71A473MA01T
68000pF(683)	±20%(M)			GMA085R71A683MA01T
0.10μF(104)	±20%(M)			GMA085R71A104MA01T
0.47μF(474)	±20%(M)			GMA085R60J474ME12T

The part number code is shown in () and Unit is shown in []. < >: EIA [inch] Code

⚠Note • This PDF catalog is downloaded from the website of Murata Manufacturing co., Ltd. Therefore, it's specifications are subject to change or our products in it may be discontinued without advance notice. Please check with our sales representatives or product engineers before ordering.
• This PDF catalog has only typical specifications because there is no space for detailed specifications. Therefore, please approve our product specifications or transact the approval sheet for product specifications before ordering.

Monolithic Ceramic Capacitors

for Bonding GMD Series

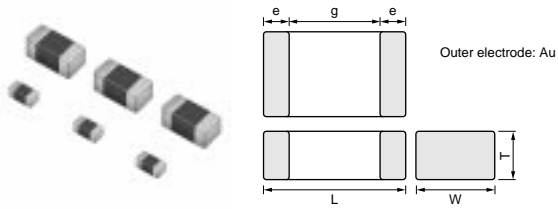

Part Number	Dimensions (mm)				
	L	W	T	e	g min.
GMD033	0.6±0.03	0.3±0.03	0.3±0.03	0.12 to 0.22	0.16
GMD155	1.0±0.05	0.5±0.05	0.5±0.05	0.15 to 0.35	0.3

● High Dielectric Constant Type X7R(R7) Characteristics

LxW [mm]		0.6x0.3(03)<0201>		
Rated Volt. [Vdc]		25(1E)	16(1C)	10(1A)
Capacitance	Tolerance	Part Number		
100pF(101)	±10%(K)	GMD033R71E101KA01D		
120pF(121)	±10%(K)	GMD033R71E121KA01D		
150pF(151)	±10%(K)	GMD033R71E151KA01D		
180pF(181)	±10%(K)	GMD033R71E181KA01D		
220pF(221)	±10%(K)	GMD033R71E221KA01D		
270pF(271)	±10%(K)	GMD033R71E271KA01D		
330pF(331)	±10%(K)	GMD033R71E331KA01D		
390pF(391)	±10%(K)	GMD033R71E391KA01D		
470pF(471)	±10%(K)	GMD033R71E471KA01D		
560pF(561)	±10%(K)	GMD033R71E561KA01D		
680pF(681)	±10%(K)	GMD033R71E681KA01D		
820pF(821)	±10%(K)	GMD033R71E821KA01D		
1000pF(102)	±10%(K)	GMD033R71E102KA01D		
1200pF(122)	±10%(K)	GMD033R71E122KA01D		
1500pF(152)	±10%(K)	GMD033R71E152KA01D		
1800pF(182)	±10%(K)		GMD033R71C182KA11D	
2200pF(222)	±10%(K)		GMD033R71C222KA11D	
2700pF(272)	±10%(K)		GMD033R71C272KA11D	
3300pF(332)	±10%(K)		GMD033R71C332KA11D	
3900pF(392)	±10%(K)			GMD033R71A392KA01D
4700pF(472)	±10%(K)			GMD033R71A472KA01D
5600pF(562)	±10%(K)			GMD033R71A562KA01D
6800pF(682)	±10%(K)			GMD033R71A682KA01D
8200pF(822)	±10%(K)			GMD033R71A822KA01D
10000pF(103)	±10%(K)			GMD033R71A103KA01D

The part number code is shown in () and Unit is shown in []. < >: EIA [inch] Code

△Note • This PDF catalog is downloaded from the website of Murata Manufacturing co., ltd. Therefore, it's specifications are subject to change or our products in it may be discontinued without advance notice. Please check with our sales representatives or product engineers before ordering.
• This PDF catalog has only typical specifications because there is no space for detailed specifications. Therefore, please approve our product specifications or transact the approval sheet for product specifications before ordering.

● High Dielectric Constant Type X7R(R7) Characteristics

LxW [mm]		1.0x0.5(15)<0402>		
Rated Volt. [Vdc]		50(1H)	25(1E)	16(1C)
Capacitance	Tolerance	Part Number		
220pF(221)	±10%(K)	GMD155R71H221KA01D		
270pF(271)	±10%(K)	GMD155R71H271KA01D		
330pF(331)	±10%(K)	GMD155R71H331KA01D		
390pF(391)	±10%(K)	GMD155R71H391KA01D		
470pF(471)	±10%(K)	GMD155R71H471KA01D		
560pF(561)	±10%(K)	GMD155R71H561KA01D		
680pF(681)	±10%(K)	GMD155R71H681KA01D		
820pF(821)	±10%(K)	GMD155R71H821KA01D		
1000pF(102)	±10%(K)	GMD155R71H102KA01D		
1200pF(122)	±10%(K)	GMD155R71H122KA01D		
1500pF(152)	±10%(K)	GMD155R71H152KA01D		
1800pF(182)	±10%(K)	GMD155R71H182KA01D		
2200pF(222)	±10%(K)	GMD155R71H222KA01D		
2700pF(272)	±10%(K)	GMD155R71H272KA01D		
3300pF(332)	±10%(K)	GMD155R71H332KA01D		
3900pF(392)	±10%(K)	GMD155R71H392KA01D		
4700pF(472)	±10%(K)	GMD155R71H472KA01D		
5600pF(562)	±10%(K)		GMD155R71E562KA01D	
6800pF(682)	±10%(K)		GMD155R71E682KA01D	
8200pF(822)	±10%(K)		GMD155R71E822KA01D	
10000pF(103)	±10%(K)		GMD155R71E103KA01D	
12000pF(123)	±10%(K)		GMD155R71E123KA01D	
15000pF(153)	±10%(K)		GMD155R71E153KA01D	
18000pF(183)	±10%(K)		GMD155R71E183KA01D	
22000pF(223)	±10%(K)		GMD155R71E223KA01D	
27000pF(273)	±10%(K)		GMD155R71E273KA11D	
33000pF(333)	±10%(K)		GMD155R71E333KA11D	
39000pF(393)	±10%(K)		GMD155R71E393KA11D	
47000pF(473)	±10%(K)		GMD155R71E473KA11D	
56000pF(563)	±10%(K)			GMD155R71C563KA11D
68000pF(683)	±10%(K)			GMD155R71C683KA11D
82000pF(823)	±10%(K)			GMD155R71C823KA11D
0.10μF(104)	±10%(K)			GMD155R71C104KA11D

The part number code is shown in () and Unit is shown in []. < >: EIA [inch] Code

● High Dielectric Constant Type X5R(R6) Characteristics

LxW [mm]		0.6x0.3(03)<0201>	1.0x0.5(15)<0402>	
Rated Volt. [Vdc]		6.3(0J)	10(1A)	6.3(0J)
Capacitance	Tolerance	Part Number		
56000pF(563)	±10%(K)	GMD033R60J563KE11D		
68000pF(683)	±10%(K)	GMD033R60J683KE11D		
82000pF(823)	±10%(K)	GMD033R60J823KE11D		
0.10μF(104)	±10%(K)	GMD033R60J104KE11D		
0.12μF(124)	±10%(K)		GMD155R61A124KE12D	
0.15μF(154)	±10%(K)		GMD155R61A154KE12D	
0.18μF(184)	±10%(K)		GMD155R61A184KE12D	
0.22μF(224)	±10%(K)		GMD155R61A224KE12D	
0.27μF(274)	±10%(K)		GMD155R61A274KE11D	
0.33μF(334)	±10%(K)		GMD155R61A334KE11D	
0.39μF(394)	±10%(K)		GMD155R61A394KE11D	
0.47μF(474)	±10%(K)		GMD155R61A474KE11D	
1.0μF(105)	±10%(K)			GMD155R60J105KE11D

The part number code is shown in () and Unit is shown in []. < >: EIA [inch] Code

⚠ Note • This PDF catalog is downloaded from the website of Murata Manufacturing co., Ltd. Therefore, it's specifications are subject to change or our products in it may be discontinued without advance notice. Please check with our sales representatives or product engineers before ordering.
• This PDF catalog has only typical specifications because there is no space for detailed specifications. Therefore, please approve our product specifications or transact the approval sheet for product specifications before ordering.

Monolithic Ceramic Capacitors

for Automotive GCM Series (Power Train, Safety Equipment)

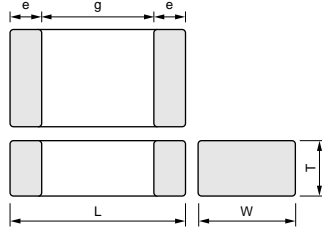

Part Number	Dimensions (mm)				
	L	W	T	e	g min.
GCM033	0.6 ±0.03	0.3 ±0.03	0.3 ±0.03	0.1 to 0.2	0.2
GCM155	1.0 ±0.05	0.5 ±0.05	0.5 ±0.05	0.15 to 0.35	0.3
GCM188*	1.6 ±0.1	0.8 ±0.1	0.8 ±0.1	0.2 to 0.5	0.5
GCM216	2.0 ±0.15	1.25 ±0.15	0.6 ±0.1	0.2 to 0.7	0.7
GCM219			0.85 ±0.1		
GCM21B			1.25 ±0.15		
GCM319	3.2 ±0.15	1.6 ±0.15	0.85 ±0.1	0.3 to 0.8	1.5
GCM31M			1.15 ±0.1		
GCM31C	3.2 ±0.2	1.6 ±0.2	1.6 ±0.2	0.3 min.	1.0
GCM32N			1.35 ±0.15		
GCM32R			1.8 ±0.2		
GCM32D	3.2 ±0.3	2.5 ±0.2	2.0 ±0.2	0.3 min.	1.0
GCM32E			2.5 ±0.2		

* Bulk Case: 1.6 ±0.07(L) × 0.8 ±0.07(W) × 0.8 ±0.07(T)

● Temperature Compensating Type

L x W [mm]		0.6x0.3(03)<0201>	1.0x0.5(15)<0402>	1.6x0.8(18)<0603>	
Rated Volt. [Vdc]		25(1E)	50(1H)	100(2A)	50(1H)
TC		COG(5C)			
Capacitance	Tolerance	Part Number			
1.0pF(1R0)	±0.25pF(C)	GCM0335C1E1R0CD03D	GCM1555C1H1R0CZ13D	GCM1885C2A1R0CZ13D	GCM1885C1H1R0CZ13D
2.0pF(2R0)	±0.25pF(C)	GCM0335C1E2R0CD03D	GCM1555C1H2R0CZ13D	GCM1885C2A2R0CZ13D	GCM1885C1H2R0CZ13D
3.0pF(3R0)	±0.25pF(C)	GCM0335C1E3R0CD03D	GCM1555C1H3R0CZ13D	GCM1885C2A3R0CZ13D	GCM1885C1H3R0CZ13D
4.0pF(4R0)	±0.25pF(C)	GCM0335C1E4R0CD03D	GCM1555C1H4R0CZ13D	GCM1885C2A4R0CZ13D	GCM1885C1H4R0CZ13D
5.0pF(5R0)	±0.25pF(C)	GCM0335C1E5R0CD03D	GCM1555C1H5R0CZ13D	GCM1885C2A5R0CZ13D	GCM1885C1H5R0CZ13D
6.0pF(6R0)	±0.5pF(D)	GCM0335C1E6R0DD03D	GCM1555C1H6R0DZ13D	GCM1885C2A6R0DZ13D	GCM1885C1H6R0DZ13D
7.0pF(7R0)	±0.5pF(D)	GCM0335C1E7R0DD03D	GCM1555C1H7R0DZ13D	GCM1885C2A7R0DZ13D	GCM1885C1H7R0DZ13D
8.0pF(8R0)	±0.5pF(D)	GCM0335C1E8R0DD03D	GCM1555C1H8R0DZ13D	GCM1885C2A8R0DZ13D	GCM1885C1H8R0DZ13D
9.0pF(9R0)	±0.5pF(D)	GCM0335C1E9R0DD03D	GCM1555C1H9R0DZ13D	GCM1885C2A9R0DZ13D	GCM1885C1H9R0DZ13D
10pF(100)	±5%(J)	GCM0335C1E100JD03D	GCM1555C1H100JZ13D	GCM1885C2A100JA16D	GCM1885C1H100JA16D
12pF(120)	±5%(J)	GCM0335C1E120JD03D	GCM1555C1H120JZ13D	GCM1885C2A120JA16D	GCM1885C1H120JA16D
15pF(150)	±5%(J)	GCM0335C1E150JD03D	GCM1555C1H150JZ13D	GCM1885C2A150JA16D	GCM1885C1H150JA16D
18pF(180)	±5%(J)	GCM0335C1E180JD03D	GCM1555C1H180JZ13D	GCM1885C2A180JA16D	GCM1885C1H180JA16D
22pF(220)	±5%(J)	GCM0335C1E220JD03D	GCM1555C1H220JZ13D	GCM1885C2A220JA16D	GCM1885C1H220JA16D
27pF(270)	±5%(J)	GCM0335C1E270JD03D	GCM1555C1H270JZ13D	GCM1885C2A270JA16D	GCM1885C1H270JA16D
33pF(330)	±5%(J)	GCM0335C1E330JD03D	GCM1555C1H330JZ13D	GCM1885C2A330JA16D	GCM1885C1H330JA16D
39pF(390)	±5%(J)	GCM0335C1E390JD03D	GCM1555C1H390JZ13D	GCM1885C2A390JA16D	GCM1885C1H390JA16D
47pF(470)	±5%(J)	GCM0335C1E470JD03D	GCM1555C1H470JZ13D	GCM1885C2A470JA16D	GCM1885C1H470JA16D
56pF(560)	±5%(J)	GCM0335C1E560JD03D	GCM1555C1H560JZ13D	GCM1885C2A560JA16D	GCM1885C1H560JA16D
68pF(680)	±5%(J)	GCM0335C1E680JD03D	GCM1555C1H680JZ13D	GCM1885C2A680JA16D	GCM1885C1H680JA16D
82pF(820)	±5%(J)	GCM0335C1E820JD03D	GCM1555C1H820JZ13D	GCM1885C2A820JA16D	GCM1885C1H820JA16D
100pF(101)	±5%(J)	GCM0335C1E101JD03D	GCM1555C1H101JZ13D	GCM1885C2A101JA16D	GCM1885C1H101JA16D
120pF(121)	±5%(J)		GCM1555C1H121JA16D	GCM1885C2A121JA16D	GCM1885C1H121JA16D
150pF(151)	±5%(J)		GCM1555C1H151JA16D	GCM1885C2A151JA16D	GCM1885C1H151JA16D
180pF(181)	±5%(J)		GCM1555C1H181JA16D	GCM1885C2A181JA16D	GCM1885C1H181JA16D
220pF(221)	±5%(J)		GCM1555C1H221JA16D	GCM1885C2A221JA16D	GCM1885C1H221JA16D
270pF(271)	±5%(J)		GCM1555C1H271JA16D	GCM1885C2A271JA16D	GCM1885C1H271JA16D
330pF(331)	±5%(J)		GCM1555C1H331JA16D	GCM1885C2A331JA16D	GCM1885C1H331JA16D
390pF(391)	±5%(J)		GCM1555C1H391JA16D	GCM1885C2A391JA16D	GCM1885C1H391JA16D
470pF(471)	±5%(J)		GCM1555C1H471JA16D	GCM1885C2A471JA16D	GCM1885C1H471JA16D
560pF(561)	±5%(J)			GCM1885C2A561JA16D	GCM1885C1H561JA16D
680pF(681)	±5%(J)			GCM1885C2A681JA16D	GCM1885C1H681JA16D
820pF(821)	±5%(J)			GCM1885C2A821JA16D	GCM1885C1H821JA16D
1000pF(102)	±5%(J)			GCM1885C2A102JA16D	GCM1885C1H102JA16D
1200pF(122)	±5%(J)			GCM1885C2A122JA16D	GCM1885C1H122JA16D
1500pF(152)	±5%(J)			GCM1885C2A152JA16D	GCM1885C1H152JA16D
1800pF(182)	±5%(J)				GCM1885C1H182JA16D
2200pF(222)	±5%(J)				GCM1885C1H222JA16D
2700pF(272)	±5%(J)				GCM1885C1H272JA16D
3300pF(332)	±5%(J)				GCM1885C1H332JA16D
3900pF(392)	±5%(J)				GCM1885C1H392JA16D

The part numbering code is shown in () and Unit is shown in []. < >: EIA [inch] Code

△Note • This PDF catalog is downloaded from the website of Murata Manufacturing Co., Ltd. Therefore, its specifications are subject to change or our products in it may be discontinued without advance notice. Please check with our sales representatives or product engineers before ordering.
• This PDF catalog has only typical specifications because there is no space for detailed specifications. Therefore, please approve our product specifications or transact the approval sheet for product specifications before ordering.

● Temperature Compensating Type

L x W [mm]		2.0x1.25(21)<0805>		3.2x1.6(31)<1206>	
Rated Volt. [Vdc]		100(2A)	50(1H)	100(2A)	50(1H)
TC		COG(5C)			
Capacitance	Tolerance	Part Number			
100pF(101)	±5%(J)	GCM2165C2A101JA16D			
120pF(121)	±5%(J)	GCM2165C2A121JA16D			
150pF(151)	±5%(J)	GCM2165C2A151JA16D			
180pF(181)	±5%(J)	GCM2165C2A181JA16D			
220pF(221)	±5%(J)	GCM2165C2A221JA16D			
270pF(271)	±5%(J)	GCM2165C2A271JA16D			
330pF(331)	±5%(J)	GCM2165C2A331JA16D			
390pF(391)	±5%(J)	GCM2165C2A391JA16D			
470pF(471)	±5%(J)	GCM2165C2A471JA16D			
560pF(561)	±5%(J)	GCM2165C2A561JA16D	GCM2165C1H561JA16D		
680pF(681)	±5%(J)	GCM2165C2A681JA16D	GCM2165C1H681JA16D		
820pF(821)	±5%(J)	GCM2165C2A821JA16D	GCM2165C1H821JA16D		
1000pF(102)	±5%(J)	GCM2165C2A102JA16D	GCM2165C1H102JA16D		
1200pF(122)	±5%(J)	GCM2165C2A122JA16D	GCM2165C1H122JA16D		
1500pF(152)	±5%(J)	GCM2165C2A152JA16D	GCM2165C1H152JA16D		
1800pF(182)	±5%(J)	GCM2165C2A182JA16D	GCM2165C1H182JA16D	GCM3195C2A182JA16D	
2200pF(222)	±5%(J)	GCM2165C2A222JA16D	GCM2165C1H222JA16D	GCM3195C2A222JA16D	
2700pF(272)	±5%(J)	GCM2165C2A272JA16D	GCM2165C1H272JA16D	GCM3195C2A272JA16D	
3300pF(332)	±5%(J)	GCM2165C2A332JA16D	GCM2165C1H332JA16D	GCM3195C2A332JA16D	
3900pF(392)	±5%(J)		GCM2165C1H392JA16D	GCM3195C2A392JA16D	
4700pF(472)	±5%(J)		GCM2165C1H472JA16D	GCM3195C2A472JA16D	GCM3195C1H472JA16D
5600pF(562)	±5%(J)		GCM2195C1H562JA16D	GCM3195C2A562JA16D	GCM3195C1H562JA16D
6800pF(682)	±5%(J)		GCM2195C1H682JA16D	GCM3195C2A682JA16D	GCM3195C1H682JA16D
8200pF(822)	±5%(J)		GCM2195C1H822JA16D	GCM3195C2A822JA16D	GCM3195C1H822JA16D
10000pF(103)	±5%(J)		GCM2195C1H103JA16D	GCM3195C2A103JA16D	GCM3195C1H103JA16D
12000pF(123)	±5%(J)		GCM2195C1H123JA16D		GCM3195C1H123JA16D
15000pF(153)	±5%(J)		GCM2195C1H153JA16D		GCM3195C1H153JA16D
18000pF(183)	±5%(J)		GCM21B5C1H183JA16L		GCM3195C1H183JA16D
22000pF(223)	±5%(J)		GCM21B5C1H223JA16L		GCM3195C1H223JA16D
27000pF(273)	±5%(J)				GCM3195C1H273JA16D
33000pF(333)	±5%(J)				GCM3195C1H333JA16D
39000pF(393)	±5%(J)				GCM3195C1H393JA16D
47000pF(473)	±5%(J)				GCM31M5C1H473JA16L
56000pF(563)	±5%(J)				GCM31M5C1H563JA16L

The part numbering code is shown in () and Unit is shown in []. < >: EIA [inch] Code

● High Dielectric Constant Type

L x W [mm]		0.6x0.3(03)<0201>		
Rated Volt. [Vdc]		25(1E)	16(1C)	10(1A)
TC		X7R(R7)		
Capacitance	Tolerance	Part Number		
100pF(101)	±10%(K)	GCM033R71E101KA03D		
150pF(151)	±10%(K)	GCM033R71E151KA03D		
220pF(221)	±10%(K)	GCM033R71E221KA03D		
330pF(331)	±10%(K)	GCM033R71E331KA03D		
470pF(471)	±10%(K)	GCM033R71E471KA03D		
680pF(681)	±10%(K)	GCM033R71E681KA03D		
1000pF(102)	±10%(K)	GCM033R71E102KA03D		
1500pF(152)	±10%(K)	GCM033R71E152KA03D		
2200pF(222)	±10%(K)		GCM033R71C222KA55D	
3300pF(332)	±10%(K)		GCM033R71C332KA55D	
4700pF(472)	±10%(K)			GCM033R71A472KA03D
6800pF(682)	±10%(K)			GCM033R71A682KA03D
10000pF(103)	±10%(K)			GCM033R71A103KA03D

L x W [mm]		1.0x0.5(15)<0402>			
Rated Volt. [Vdc]		100(2A)	50(1H)	25(1E)	16(1C)
TC		X7R(R7)			
Capacitance	Tolerance	Part Number			
220pF(221)	±10%(K)	GCM155R72A221KA37D	GCM155R71H221KA37D		
330pF(331)	±10%(K)	GCM155R72A331KA37D	GCM155R71H331KA37D		
470pF(471)	±10%(K)	GCM155R72A471KA37D	GCM155R71H471KA37D		
680pF(681)	±10%(K)	GCM155R72A681KA37D	GCM155R71H681KA37D		
1000pF(102)	±10%(K)	GCM155R72A102KA37D	GCM155R71H102KA37D		
1500pF(152)	±10%(K)	GCM155R72A152KA37D	GCM155R71H152KA37D		
2200pF(222)	±10%(K)	GCM155R72A222KA37D	GCM155R71H222KA37D		
3300pF(332)	±10%(K)	GCM155R72A332KA37D	GCM155R71H332KA37D		
4700pF(472)	±10%(K)	GCM155R72A472KA37D	GCM155R71H472KA37D		
6800pF(682)	±10%(K)		GCM155R71H682KA55D		
10000pF(103)	±10%(K)		GCM155R71H103KA55D	GCM155R71E103KA37D	
15000pF(153)	±10%(K)		GCM155R71H153KA55D	GCM155R71E153KA55D	
22000pF(223)	±10%(K)		GCM155R71H223KA55D	GCM155R71E223KA55D	
33000pF(333)	±10%(K)			GCM155R71E333KA55D	GCM155R71C333KA37D
47000pF(473)	±10%(K)			GCM155R71E473KA55D	GCM155R71C473KA37D
68000pF(683)	±10%(K)				GCM155R71C683KA55D
0.10μF(104)	±10%(K)				GCM155R71C104KA55D

The part numbering code is shown in () and Unit is shown in []. < >: EIA [inch] Code

△Note • This PDF catalog is downloaded from the website of Murata Manufacturing co., ltd. Therefore, it's specifications are subject to change or our products in it may be discontinued without advance notice. Please check with our sales representatives or product engineers before ordering.
• This PDF catalog has only typical specifications because there is no space for detailed specifications. Therefore, please approve our product specifications or transact the approval sheet for product specifications before ordering.

● High Dielectric Constant Type

L x W [mm]		1.6x0.8(18)<0603>			
Rated Volt. [Vdc]		100(2A)	50(1H)	25(1E)	16(1C)
TC		X7R(R7)/X7S(C7)			
Capacitance	Tolerance	Part Number			
1000pF(102)	±10%(K)	GCM188R72A102KA37D	GCM188R71H102KA37D		
1500pF(152)	±10%(K)	GCM188R72A152KA37D	GCM188R71H152KA37D		
2200pF(222)	±10%(K)	GCM188R72A222KA37D	GCM188R71H222KA37D		
3300pF(332)	±10%(K)	GCM188R72A332KA37D	GCM188R71H332KA37D		
4700pF(472)	±10%(K)	GCM188R72A472KA37D	GCM188R71H472KA37D		
6800pF(682)	±10%(K)	GCM188R72A682KA37D	GCM188R71H682KA37D		
10000pF(103)	±10%(K)	GCM188R72A103KA37D	GCM188R71H103KA37D		
15000pF(153)	±10%(K)	GCM188R72A153KA37D	GCM188R71H153KA37D		
22000pF(223)	±10%(K)	GCM188R72A223KA37D	GCM188R71H223KA37D		
33000pF(333)	±10%(K)		GCM188R71H333KA55D	GCM188R71E333KA37D	
47000pF(473)	±10%(K)		GCM188R71H473KA55D	GCM188R71E473KA37D	
68000pF(683)	±10%(K)		GCM188R71H683KA57D	GCM188R71E683KA57D	
0.10μF(104)	±10%(K)	GCM188R72A104KA64D	GCM188R71H104KA57D	GCM188R71E104KA57D	GCM188R71C104KA37D
0.15μF(154)	±10%(K)		GCM188R71H154KA64D	GCM188R71E154KA37D	
0.22μF(224)	±10%(K)		GCM188R71H224KA64D	GCM188R71E224KA55D	
0.33μF(334)	±10%(K)				GCM188R71C334KA37D
0.47μF(474)	±10%(K)			GCM188R71E474KA64D	GCM188R71C474KA55D
0.68μF(684)	±10%(K)				GCM188C71C684KA64D
1.0μF(105)	±10%(K)			GCM188R71E105KA64D	GCM188R71C105KA64D

L x W [mm]		1.6x0.8(18)<0603>	
Rated Volt. [Vdc]		6.3(0J)	
TC		X7R(R7)	
Capacitance	Tolerance	Part Number	
2.2μF(225)	±10%(K)	GCM188R70J225KE22D	

L x W [mm]		2.0x1.25(21)<0805>			
Rated Volt. [Vdc]		100(2A)	50(1H)	35(YA)	25(1E)
TC		X7R(R7)			
Capacitance	Tolerance	Part Number			
6800pF(682)	±10%(K)	GCM216R72A682KA37D			
10000pF(103)	±10%(K)	GCM216R72A103KA37D			
15000pF(153)	±10%(K)	GCM216R72A153KA37D			
22000pF(223)	±10%(K)	GCM216R72A223KA37D			
33000pF(333)	±10%(K)	GCM219R72A333KA37D	GCM219R71H333KA37D		
47000pF(473)	±10%(K)	GCM21BR72A473KA37L	GCM21BR71H473KA37L		
68000pF(683)	±10%(K)	GCM21BR72A683KA37L	GCM21BR71H683KA37L		
0.10μF(104)	±10%(K)	GCM21BR72A104KA37L	GCM21BR71H104KA37L		
0.15μF(154)	±10%(K)		GCM21BR71H154KA37L		GCM21BR71E154KA37L
0.22μF(224)	±10%(K)		GCM21BR71H224KA37L		GCM21BR71E224KA37L
0.33μF(334)	±10%(K)		GCM219R71H334KA55D		GCM21BR71E334KA37L
0.47μF(474)	±10%(K)		GCM21BR71H474KA55L		GCM219R71E474KA55D
0.68μF(684)	±10%(K)			GCM21BR7YA684KA55L	GCM21BR71E684KA55L
1.0μF(105)	±10%(K)			GCM21BR7YA105KA55L	GCM21BR71E105KA56L
2.2μF(225)	±10%(K)				GCM21BR71E225KA73L

The part numbering code is shown in () and Unit is shown in []. < >: EIA [inch] Code

● High Dielectric Constant Type

L x W [mm]		2.0x1.25(21)<0805>		
Rated Volt. [Vdc]		16(1C)	10(1A)	6.3(0J)
TC		X7R(R7)/X7S(C7)		
Capacitance	Tolerance	Part Number		
0.68μF(684)	±10%(K)	GCM219R71C684KA37D		
1.0μF(105)	±10%(K)	GCM219R71C105KA37D		
2.2μF(225)	±10%(K)	GCM21BR71C225KA64L	GCM21BR71A225KA37L	
4.7μF(475)	±10%(K)	GCM21BR71C475KA73L	GCM21BC71A475KA73L	
10μF(106)	±10%(K)			GCM21BR70J106KE22L

L x W [mm]		3.2x1.6(31)<1206>			
Rated Volt. [Vdc]		100(2A)	50(1H)	25(1E)	16(1C)
TC		X7R(R7)			
Capacitance	Tolerance	Part Number			
0.10μF(104)	±10%(K)	GCM319R72A104KA37D			
0.15μF(154)	±10%(K)	GCM31MR72A154KA37L			
0.22μF(224)	±10%(K)	GCM31MR72A224KA37L			
0.33μF(334)	±10%(K)		GCM31MR71H334KA37L		
0.47μF(474)	±10%(K)		GCM31MR71H474KA37L		
0.68μF(684)	±10%(K)		GCM31MR71H684KA55L		
1.0μF(105)	±10%(K)		GCM31MR71H105KA55L		
2.2μF(225)	±10%(K)		GCM31CR71H225KA55L	GCM31MR71E225KA57L	
4.7μF(475)	±10%(K)			GCM31CR71E475KA55L	GCM31CR71C475KA37L
10μF(106)	±10%(K)				GCM31CR71C106KA64L

L x W [mm]		3.2x1.6(31)<1206>	
Rated Volt. [Vdc]		10(1A)	6.3(0J)
TC		X7R(R7)	
Capacitance	Tolerance	Part Number	
10μF(106)	±10%(K)	GCM31CR71A106KA64L	
22μF(226)	±20%(M)		GCM31CR70J226ME23L

L x W [mm]		3.2x2.5(32)<1210>			
Rated Volt. [Vdc]		100(2A)	50(1H)	25(1E)	16(1C)
TC		X7R(R7)			
Capacitance	Tolerance	Part Number			
1.0μF(105)	±10%(K)		GCM32ER71H105KA37L		
2.2μF(225)	±10%(K)	GCM32DR72A225KA64L			
4.7μF(475)	±10%(K)		GCM32ER71H475KA55L	GCM32DR71E475KA55L	
10μF(106)	±10%(K)			GCM32ER71E106KA57L	GCM32DR71C106KA37L
22μF(226)	±20%(M)				GCM32ER71C226ME19L

L x W [mm]		3.2x2.5(32)<1210>	
Rated Volt. [Vdc]		10(1A)	6.3(0J)
TC		X7R(R7)	
Capacitance	Tolerance	Part Number	
22μF(226)	±20%(M)	GCM32ER71A226ME12L	
47μF(476)	±20%(M)		GCM32ER70J476ME19L

The part numbering code is shown in () and Unit is shown in []. < >: EIA [inch] Code

△Note • This PDF catalog is downloaded from the website of Murata Manufacturing co., ltd. Therefore, it's specifications are subject to change or our products in it may be discontinued without advance notice. Please check with our sales representatives or product engineers before ordering.
• This PDF catalog has only typical specifications because there is no space for detailed specifications. Therefore, please approve our product specifications or transact the approval sheet for product specifications before ordering.

Monolithic Ceramic Capacitors for Medium Voltage

Low Dissipation Factor

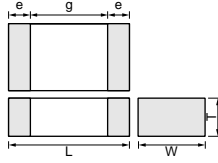

Part Number	Dimensions (mm)				
	L	W	T	e min.	g min.
GRM21A	2.0 ±0.2	1.25 ±0.2	1.0 +0,-0.3	0.3	0.7
GRM31A	3.2 ±0.2	1.6 ±0.2	1.25 +0,-0.3		1.5*
GRM31B			1.0 +0,-0.3		
GRM32A	3.2 ±0.2	2.5 ±0.2	1.25 +0,-0.3		
GRM32B			1.0 +0,-0.3		
GRM42A	4.5 ±0.3	2.0 ±0.2	1.0 +0,-0.3		2.9

* GRM31A7U3D, GRM32A7U3D, GRM32B7U3D : 1.8mm min.

COG Characteristics

Part Number	Rated Voltage (V)	TC Code (Standard)	Capacitance (pF)	Length L (mm)	Width W (mm)	Thickness T (mm)	Electrode g (min.) (mm)	Electrode e (mm)
GRM31A5C2J101JW01D	DC630	COG (EIA)	100 ±5%	3.2	1.6	1.0	1.5	0.3 min.
GRM31A5C2J121JW01D	DC630	COG (EIA)	120 ±5%	3.2	1.6	1.0	1.5	0.3 min.
GRM31A5C2J151JW01D	DC630	COG (EIA)	150 ±5%	3.2	1.6	1.0	1.5	0.3 min.
GRM31A5C2J181JW01D	DC630	COG (EIA)	180 ±5%	3.2	1.6	1.0	1.5	0.3 min.
GRM31A5C2J221JW01D	DC630	COG (EIA)	220 ±5%	3.2	1.6	1.0	1.5	0.3 min.
GRM31A5C2J271JW01D	DC630	COG (EIA)	270 ±5%	3.2	1.6	1.0	1.5	0.3 min.
GRM31A5C2J331JW01D	DC630	COG (EIA)	330 ±5%	3.2	1.6	1.0	1.5	0.3 min.
GRM31A5C2J391JW01D	DC630	COG (EIA)	390 ±5%	3.2	1.6	1.0	1.5	0.3 min.
GRM31A5C2J471JW01D	DC630	COG (EIA)	470 ±5%	3.2	1.6	1.0	1.5	0.3 min.
GRM31A5C2J561JW01D	DC630	COG (EIA)	560 ±5%	3.2	1.6	1.0	1.5	0.3 min.
GRM31B5C2J681JW01L	DC630	COG (EIA)	680 ±5%	3.2	1.6	1.25	1.5	0.3 min.
GRM31B5C2J821JW01L	DC630	COG (EIA)	820 ±5%	3.2	1.6	1.25	1.5	0.3 min.
GRM31B5C2J102JW01L	DC630	COG (EIA)	1000 ±5%	3.2	1.6	1.25	1.5	0.3 min.

Operating Temperature Range: -55 to +125deg.
Only tape packaging is available.

U2J Characteristics

Part Number	Rated Voltage (V)	TC Code (Standard)	Capacitance (pF)	Length L (mm)	Width W (mm)	Thickness T (mm)	Electrode g (min.) (mm)	Electrode e (mm)
GRM21A7U2E101JW31D	DC250	U2J (EIA)	100 ±5%	2.0	1.25	1.0	0.7	0.3 min.
GRM21A7U2E121JW31D	DC250	U2J (EIA)	120 ±5%	2.0	1.25	1.0	0.7	0.3 min.
GRM21A7U2E151JW31D	DC250	U2J (EIA)	150 ±5%	2.0	1.25	1.0	0.7	0.3 min.
GRM21A7U2E181JW31D	DC250	U2J (EIA)	180 ±5%	2.0	1.25	1.0	0.7	0.3 min.
GRM21A7U2E221JW31D	DC250	U2J (EIA)	220 ±5%	2.0	1.25	1.0	0.7	0.3 min.
GRM21A7U2E271JW31D	DC250	U2J (EIA)	270 ±5%	2.0	1.25	1.0	0.7	0.3 min.
GRM21A7U2E331JW31D	DC250	U2J (EIA)	330 ±5%	2.0	1.25	1.0	0.7	0.3 min.
GRM21A7U2E391JW31D	DC250	U2J (EIA)	390 ±5%	2.0	1.25	1.0	0.7	0.3 min.
GRM21A7U2E471JW31D	DC250	U2J (EIA)	470 ±5%	2.0	1.25	1.0	0.7	0.3 min.
GRM21A7U2E561JW31D	DC250	U2J (EIA)	560 ±5%	2.0	1.25	1.0	0.7	0.3 min.
GRM21A7U2E681JW31D	DC250	U2J (EIA)	680 ±5%	2.0	1.25	1.0	0.7	0.3 min.
GRM21A7U2E821JW31D	DC250	U2J (EIA)	820 ±5%	2.0	1.25	1.0	0.7	0.3 min.
GRM21A7U2E102JW31D	DC250	U2J (EIA)	1000 ±5%	2.0	1.25	1.0	0.7	0.3 min.
GRM21A7U2E122JW31D	DC250	U2J (EIA)	1200 ±5%	2.0	1.25	1.0	0.7	0.3 min.
GRM21A7U2E152JW31D	DC250	U2J (EIA)	1500 ±5%	2.0	1.25	1.0	0.7	0.3 min.
GRM21A7U2E182JW31D	DC250	U2J (EIA)	1800 ±5%	2.0	1.25	1.0	0.7	0.3 min.
GRM21A7U2E222JW31D	DC250	U2J (EIA)	2200 ±5%	2.0	1.25	1.0	0.7	0.3 min.
GRM31A7U2E272JW31D	DC250	U2J (EIA)	2700 ±5%	3.2	1.6	1.0	1.5	0.3 min.

Continued on the following page.

Continued from the preceding page.

Part Number	Rated Voltage (V)	TC Code (Standard)	Capacitance (pF)	Length L (mm)	Width W (mm)	Thickness T (mm)	Electrode g (min.) (mm)	Electrode e (mm)
GRM31A7U2E332JW31D	DC250	U2J (EIA)	3300 ±5%	3.2	1.6	1.0	1.5	0.3 min.
GRM31A7U2E392JW31D	DC250	U2J (EIA)	3900 ±5%	3.2	1.6	1.0	1.5	0.3 min.
GRM31A7U2E472JW31D	DC250	U2J (EIA)	4700 ±5%	3.2	1.6	1.0	1.5	0.3 min.
GRM31A7U2E562JW31D	DC250	U2J (EIA)	5600 ±5%	3.2	1.6	1.0	1.5	0.3 min.
GRM31B7U2E682JW31L	DC250	U2J (EIA)	6800 ±5%	3.2	1.6	1.25	1.5	0.3 min.
GRM31B7U2E822JW31L	DC250	U2J (EIA)	8200 ±5%	3.2	1.6	1.25	1.5	0.3 min.
GRM31B7U2E103JW31L	DC250	U2J (EIA)	10000 ±5%	3.2	1.6	1.25	1.5	0.3 min.
GRM31A7U2J100JW31D	DC630	U2J (EIA)	10 ±5%	3.2	1.6	1.0	1.5	0.3 min.
GRM31A7U2J120JW31D	DC630	U2J (EIA)	12 ±5%	3.2	1.6	1.0	1.5	0.3 min.
GRM31A7U2J150JW31D	DC630	U2J (EIA)	15 ±5%	3.2	1.6	1.0	1.5	0.3 min.
GRM31A7U2J180JW31D	DC630	U2J (EIA)	18 ±5%	3.2	1.6	1.0	1.5	0.3 min.
GRM31A7U2J220JW31D	DC630	U2J (EIA)	22 ±5%	3.2	1.6	1.0	1.5	0.3 min.
GRM31A7U2J270JW31D	DC630	U2J (EIA)	27 ±5%	3.2	1.6	1.0	1.5	0.3 min.
GRM31A7U2J330JW31D	DC630	U2J (EIA)	33 ±5%	3.2	1.6	1.0	1.5	0.3 min.
GRM31A7U2J390JW31D	DC630	U2J (EIA)	39 ±5%	3.2	1.6	1.0	1.5	0.3 min.
GRM31A7U2J470JW31D	DC630	U2J (EIA)	47 ±5%	3.2	1.6	1.0	1.5	0.3 min.
GRM31A7U2J560JW31D	DC630	U2J (EIA)	56 ±5%	3.2	1.6	1.0	1.5	0.3 min.
GRM31A7U2J680JW31D	DC630	U2J (EIA)	68 ±5%	3.2	1.6	1.0	1.5	0.3 min.
GRM31A7U2J820JW31D	DC630	U2J (EIA)	82 ±5%	3.2	1.6	1.0	1.5	0.3 min.
GRM31A7U2J101JW31D	DC630	U2J (EIA)	100 ±5%	3.2	1.6	1.0	1.5	0.3 min.
GRM31A7U2J121JW31D	DC630	U2J (EIA)	120 ±5%	3.2	1.6	1.0	1.5	0.3 min.
GRM31A7U2J151JW31D	DC630	U2J (EIA)	150 ±5%	3.2	1.6	1.0	1.5	0.3 min.
GRM31A7U2J181JW31D	DC630	U2J (EIA)	180 ±5%	3.2	1.6	1.0	1.5	0.3 min.
GRM31A7U2J221JW31D	DC630	U2J (EIA)	220 ±5%	3.2	1.6	1.0	1.5	0.3 min.
GRM31A7U2J271JW31D	DC630	U2J (EIA)	270 ±5%	3.2	1.6	1.0	1.5	0.3 min.
GRM31A7U2J331JW31D	DC630	U2J (EIA)	330 ±5%	3.2	1.6	1.0	1.5	0.3 min.
GRM31A7U2J391JW31D	DC630	U2J (EIA)	390 ±5%	3.2	1.6	1.0	1.5	0.3 min.
GRM31A7U2J471JW31D	DC630	U2J (EIA)	470 ±5%	3.2	1.6	1.0	1.5	0.3 min.
GRM31A7U2J561JW31D	DC630	U2J (EIA)	560 ±5%	3.2	1.6	1.0	1.5	0.3 min.
GRM31A7U2J681JW31D	DC630	U2J (EIA)	680 ±5%	3.2	1.6	1.0	1.5	0.3 min.
GRM31A7U2J821JW31D	DC630	U2J (EIA)	820 ±5%	3.2	1.6	1.0	1.5	0.3 min.
GRM31A7U2J102JW31D	DC630	U2J (EIA)	1000 ±5%	3.2	1.6	1.0	1.5	0.3 min.
GRM32A7U2J122JW31D	DC630	U2J (EIA)	1200 ±5%	3.2	2.5	1.0	1.5	0.3 min.
GRM32A7U2J152JW31D	DC630	U2J (EIA)	1500 ±5%	3.2	2.5	1.0	1.5	0.3 min.
GRM32A7U2J182JW31D	DC630	U2J (EIA)	1800 ±5%	3.2	2.5	1.0	1.5	0.3 min.
GRM32A7U2J222JW31D	DC630	U2J (EIA)	2200 ±5%	3.2	2.5	1.0	1.5	0.3 min.
GRM31A7U3A100JW31D	DC1000	U2J (EIA)	10 ±5%	3.2	1.6	1.0	1.5	0.3 min.
GRM31A7U3A120JW31D	DC1000	U2J (EIA)	12 ±5%	3.2	1.6	1.0	1.5	0.3 min.
GRM31A7U3A150JW31D	DC1000	U2J (EIA)	15 ±5%	3.2	1.6	1.0	1.5	0.3 min.
GRM31A7U3A180JW31D	DC1000	U2J (EIA)	18 ±5%	3.2	1.6	1.0	1.5	0.3 min.
GRM31A7U3A220JW31D	DC1000	U2J (EIA)	22 ±5%	3.2	1.6	1.0	1.5	0.3 min.
GRM31A7U3A270JW31D	DC1000	U2J (EIA)	27 ±5%	3.2	1.6	1.0	1.5	0.3 min.
GRM31A7U3A330JW31D	DC1000	U2J (EIA)	33 ±5%	3.2	1.6	1.0	1.5	0.3 min.
GRM31A7U3A390JW31D	DC1000	U2J (EIA)	39 ±5%	3.2	1.6	1.0	1.5	0.3 min.
GRM31A7U3A470JW31D	DC1000	U2J (EIA)	47 ±5%	3.2	1.6	1.0	1.5	0.3 min.
GRM31A7U3A560JW31D	DC1000	U2J (EIA)	56 ±5%	3.2	1.6	1.0	1.5	0.3 min.
GRM31A7U3A680JW31D	DC1000	U2J (EIA)	68 ±5%	3.2	1.6	1.0	1.5	0.3 min.
GRM31A7U3A820JW31D	DC1000	U2J (EIA)	82 ±5%	3.2	1.6	1.0	1.5	0.3 min.
GRM31A7U3A101JW31D	DC1000	U2J (EIA)	100 ±5%	3.2	1.6	1.0	1.5	0.3 min.
GRM31A7U3A121JW31D	DC1000	U2J (EIA)	120 ±5%	3.2	1.6	1.0	1.5	0.3 min.
GRM31A7U3A151JW31D	DC1000	U2J (EIA)	150 ±5%	3.2	1.6	1.0	1.5	0.3 min.
GRM31A7U3A181JW31D	DC1000	U2J (EIA)	180 ±5%	3.2	1.6	1.0	1.5	0.3 min.
GRM31A7U3A221JW31D	DC1000	U2J (EIA)	220 ±5%	3.2	1.6	1.0	1.5	0.3 min.
GRM31A7U3A271JW31D	DC1000	U2J (EIA)	270 ±5%	3.2	1.6	1.0	1.5	0.3 min.
GRM31A7U3A331JW31D	DC1000	U2J (EIA)	330 ±5%	3.2	1.6	1.0	1.5	0.3 min.

Continued on the following page.

Note • This PDF catalog is downloaded from the website of Murata Manufacturing co., ltd. Therefore, it's specifications are subject to change or our products in it may be discontinued without advance notice. Please check with our sales representatives or product engineers before ordering.
 • This PDF catalog has only typical specifications because there is no space for detailed specifications. Therefore, please approve our product specifications or transact the approval sheet for product specifications before ordering.

Continued from the preceding page.

Part Number	Rated Voltage (V)	TC Code (Standard)	Capacitance (pF)	Length L (mm)	Width W (mm)	Thickness T (mm)	Electrode g (min.) (mm)	Electrode e (mm)
GRM31B7U3A391JW31L	DC1000	U2J (EIA)	390 ±5%	3.2	1.6	1.25	1.5	0.3 min.
GRM31B7U3A471JW31L	DC1000	U2J (EIA)	470 ±5%	3.2	1.6	1.25	1.5	0.3 min.
GRM31A7U3D100JW31D	DC2000	U2J (EIA)	10 ±5%	3.2	1.6	1.0	1.8	0.3 min.
GRM31A7U3D120JW31D	DC2000	U2J (EIA)	12 ±5%	3.2	1.6	1.0	1.8	0.3 min.
GRM31A7U3D150JW31D	DC2000	U2J (EIA)	15 ±5%	3.2	1.6	1.0	1.8	0.3 min.
GRM31A7U3D180JW31D	DC2000	U2J (EIA)	18 ±5%	3.2	1.6	1.0	1.8	0.3 min.
GRM31A7U3D220JW31D	DC2000	U2J (EIA)	22 ±5%	3.2	1.6	1.0	1.8	0.3 min.
GRM31A7U3D270JW31D	DC2000	U2J (EIA)	27 ±5%	3.2	1.6	1.0	1.8	0.3 min.
GRM31A7U3D330JW31D	DC2000	U2J (EIA)	33 ±5%	3.2	1.6	1.0	1.8	0.3 min.
GRM31A7U3D390JW31D	DC2000	U2J (EIA)	39 ±5%	3.2	1.6	1.0	1.8	0.3 min.
GRM31A7U3D470JW31D	DC2000	U2J (EIA)	47 ±5%	3.2	1.6	1.0	1.8	0.3 min.
GRM31A7U3D560JW31D	DC2000	U2J (EIA)	56 ±5%	3.2	1.6	1.0	1.8	0.3 min.
GRM31A7U3D680JW31D	DC2000	U2J (EIA)	68 ±5%	3.2	1.6	1.0	1.8	0.3 min.
GRM32A7U3D820JW31D	DC2000	U2J (EIA)	82 ±5%	3.2	2.5	1.0	1.8	0.3 min.
GRM32A7U3D101JW31D	DC2000	U2J (EIA)	100 ±5%	3.2	2.5	1.0	1.8	0.3 min.
GRM32A7U3D121JW31D	DC2000	U2J (EIA)	120 ±5%	3.2	2.5	1.0	1.8	0.3 min.
GRM32A7U3D151JW31D	DC2000	U2J (EIA)	150 ±5%	3.2	2.5	1.0	1.8	0.3 min.
GRM32B7U3D181JW31L	DC2000	U2J (EIA)	180 ±5%	3.2	2.5	1.25	1.8	0.3 min.
GRM32B7U3D221JW31L	DC2000	U2J (EIA)	220 ±5%	3.2	2.5	1.25	1.8	0.3 min.
GRM42A7U3F270JW31L	DC3150	U2J (EIA)	27 ±5%	4.5	2.0	1.0	2.9	0.3 min.
GRM42A7U3F330JW31L	DC3150	U2J (EIA)	33 ±5%	4.5	2.0	1.0	2.9	0.3 min.
GRM42A7U3F390JW31L	DC3150	U2J (EIA)	39 ±5%	4.5	2.0	1.0	2.9	0.3 min.
GRM42A7U3F470JW31L	DC3150	U2J (EIA)	47 ±5%	4.5	2.0	1.0	2.9	0.3 min.
GRM42A7U3F560JW31L	DC3150	U2J (EIA)	56 ±5%	4.5	2.0	1.0	2.9	0.3 min.
GRM42A7U3F680JW31L	DC3150	U2J (EIA)	68 ±5%	4.5	2.0	1.0	2.9	0.3 min.
GRM42A7U3F820JW31L	DC3150	U2J (EIA)	82 ±5%	4.5	2.0	1.0	2.9	0.3 min.
GRM42A7U3F101JW31L	DC3150	U2J (EIA)	100 ±5%	4.5	2.0	1.0	2.9	0.3 min.

Operating Temperature Range: -55 to +125deg.

Only tape packaging is available.

Monolithic Ceramic Capacitors for Medium Voltage

High Capacitance for General Use

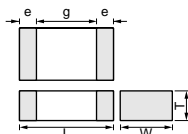

Part Number	Dimensions (mm)				
	L	W	T	e	g min.
GRM188	1.6 ±0.1	0.8 ±0.1	0.8 ±0.1	0.2 to 0.5	0.4
GRM21A	2.0 ±0.2	1.25 ±0.2	1.0 +0, -0.3		0.3 min.
GRM21B			1.25 ±0.2		
GRM31B	3.2 ±0.2	1.6 ±0.2	1.25 +0, -0.3	1.2	
GRM31C			1.6 ±0.2		
GRM32Q			3.2 ±0.3	2.5 ±0.2	
GRM32D	2.0 +0, -0.3				
GRM43Q	4.5 ±0.4	3.2 ±0.3	1.5 +0, -0.3	2.2	
GRM43D			2.0 +0, -0.3		
GRM55D	5.7 ±0.4	5.0 ±0.4	2.0 +0, -0.3	3.2	

Part Number	Rated Voltage (V)	TC Code (Standard)	Capacitance	Length L (mm)	Width W (mm)	Thickness T (mm)	Electrode g (min.) (mm)	Electrode e (mm)
GRM188R72E221KW07D	DC250	X7R (EIA)	220pF ±10%	1.6	0.8	0.8	0.4	0.2 to 0.5
GRM188R72E331KW07D	DC250	X7R (EIA)	330pF ±10%	1.6	0.8	0.8	0.4	0.2 to 0.5
GRM188R72E471KW07D	DC250	X7R (EIA)	470pF ±10%	1.6	0.8	0.8	0.4	0.2 to 0.5
GRM188R72E681KW07D	DC250	X7R (EIA)	680pF ±10%	1.6	0.8	0.8	0.4	0.2 to 0.5
GRM188R72E102KW07D	DC250	X7R (EIA)	1000pF ±10%	1.6	0.8	0.8	0.4	0.2 to 0.5

Continued on the following page.

Continued from the preceding page.

Part Number	Rated Voltage (V)	TC Code (Standard)	Capacitance	Length L (mm)	Width W (mm)	Thickness T (mm)	Electrode g (min.) (mm)	Electrode e (mm)
GRM21AR72E102KW01D	DC250	X7R (EIA)	1000pF ±10%	2.0	1.25	1.0	0.7	0.3 min.
GRM188R72E152KW07D	DC250	X7R (EIA)	1500pF ±10%	1.6	0.8	0.8	0.4	0.2 to 0.5
GRM21AR72E152KW01D	DC250	X7R (EIA)	1500pF ±10%	2.0	1.25	1.0	0.7	0.3 min.
GRM188R72E222KW07D	DC250	X7R (EIA)	2200pF ±10%	1.6	0.8	0.8	0.4	0.2 to 0.5
GRM21AR72E222KW01D	DC250	X7R (EIA)	2200pF ±10%	2.0	1.25	1.0	0.7	0.3 min.
GRM21AR72E332KW01D	DC250	X7R (EIA)	3300pF ±10%	2.0	1.25	1.0	0.7	0.3 min.
GRM21AR72E472KW01D	DC250	X7R (EIA)	4700pF ±10%	2.0	1.25	1.0	0.7	0.3 min.
GRM21AR72E682KW01D	DC250	X7R (EIA)	6800pF ±10%	2.0	1.25	1.0	0.7	0.3 min.
GRM21BR72E103KW03L	DC250	X7R (EIA)	10000pF ±10%	2.0	1.25	1.25	0.7	0.3 min.
GRM31BR72E153KW01L	DC250	X7R (EIA)	15000pF ±10%	3.2	1.6	1.25	1.2	0.3 min.
GRM31BR72E223KW01L	DC250	X7R (EIA)	22000pF ±10%	3.2	1.6	1.25	1.2	0.3 min.
GRM31CR72E333KW03L	DC250	X7R (EIA)	33000pF ±10%	3.2	1.6	1.6	1.2	0.3 min.
GRM31CR72E473KW03L	DC250	X7R (EIA)	47000pF ±10%	3.2	1.6	1.6	1.2	0.3 min.
GRM31BR72E683KW01L	DC250	X7R (EIA)	68000pF ±10%	3.2	1.6	1.25	1.2	0.3 min.
GRM32QR72E683KW01L	DC250	X7R (EIA)	68000pF ±10%	3.2	2.5	1.5	1.2	0.3 min.
GRM31CR72E104KW03L	DC250	X7R (EIA)	0.10μF ±10%	3.2	1.6	1.6	1.2	0.3 min.
GRM32DR72E104KW01L	DC250	X7R (EIA)	0.10μF ±10%	3.2	2.5	2.0	1.2	0.3 min.
GRM32QR72E154KW01L	DC250	X7R (EIA)	0.15μF ±10%	3.2	2.5	1.5	1.2	0.3 min.
GRM43QR72E154KW01L	DC250	X7R (EIA)	0.15μF ±10%	4.5	3.2	1.5	2.2	0.3 min.
GRM32DR72E224KW01L	DC250	X7R (EIA)	0.22μF ±10%	3.2	2.5	2.0	1.2	0.3 min.
GRM43DR72E224KW01L	DC250	X7R (EIA)	0.22μF ±10%	4.5	3.2	2.0	2.2	0.3 min.
GRM43DR72E334KW01L	DC250	X7R (EIA)	0.33μF ±10%	4.5	3.2	2.0	2.2	0.3 min.
GRM55DR72E334KW01L	DC250	X7R (EIA)	0.33μF ±10%	5.7	5.0	2.0	3.2	0.3 min.
GRM43DR72E474KW01L	DC250	X7R (EIA)	0.47μF ±10%	4.5	3.2	2.0	2.2	0.3 min.
GRM55DR72E474KW01L	DC250	X7R (EIA)	0.47μF ±10%	5.7	5.0	2.0	3.2	0.3 min.
GRM55DR72E105KW01L	DC250	X7R (EIA)	1.0μF ±10%	5.7	5.0	2.0	3.2	0.3 min.
GRM31BR72J102KW01L	DC630	X7R (EIA)	1000pF ±10%	3.2	1.6	1.25	1.2	0.3 min.
GRM31BR72J152KW01L	DC630	X7R (EIA)	1500pF ±10%	3.2	1.6	1.25	1.2	0.3 min.
GRM31BR72J222KW01L	DC630	X7R (EIA)	2200pF ±10%	3.2	1.6	1.25	1.2	0.3 min.
GRM31BR72J332KW01L	DC630	X7R (EIA)	3300pF ±10%	3.2	1.6	1.25	1.2	0.3 min.
GRM31BR72J472KW01L	DC630	X7R (EIA)	4700pF ±10%	3.2	1.6	1.25	1.2	0.3 min.
GRM31BR72J682KW01L	DC630	X7R (EIA)	6800pF ±10%	3.2	1.6	1.25	1.2	0.3 min.
GRM31BR72J103KW01L	DC630	X7R (EIA)	10000pF ±10%	3.2	1.6	1.25	1.2	0.3 min.
GRM31CR72J153KW03L	DC630	X7R (EIA)	15000pF ±10%	3.2	1.6	1.6	1.2	0.3 min.
GRM32QR72J223KW01L	DC630	X7R (EIA)	22000pF ±10%	3.2	2.5	1.5	1.2	0.3 min.
GRM32DR72J333KW01L	DC630	X7R (EIA)	33000pF ±10%	3.2	2.5	2.0	1.2	0.3 min.
GRM32DR72J473KW01L	DC630	X7R (EIA)	47000pF ±10%	3.2	2.5	2.0	1.2	0.3 min.
GRM43QR72J683KW01L	DC630	X7R (EIA)	68000pF ±10%	4.5	3.2	1.5	2.2	0.3 min.
GRM43DR72J104KW01L	DC630	X7R (EIA)	0.10μF ±10%	4.5	3.2	2.0	2.2	0.3 min.
GRM55DR72J154KW01L	DC630	X7R (EIA)	0.15μF ±10%	5.7	5.0	2.0	3.2	0.3 min.
GRM55DR72J224KW01L	DC630	X7R (EIA)	0.22μF ±10%	5.7	5.0	2.0	3.2	0.3 min.
GRM31BR73A471KW01L	DC1000	X7R (EIA)	470pF ±10%	3.2	1.6	1.25	1.2	0.3 min.
GRM31BR73A102KW01L	DC1000	X7R (EIA)	1000pF ±10%	3.2	1.6	1.25	1.2	0.3 min.
GRM31BR73A152KW01L	DC1000	X7R (EIA)	1500pF ±10%	3.2	1.6	1.25	1.2	0.3 min.
GRM31BR73A222KW01L	DC1000	X7R (EIA)	2200pF ±10%	3.2	1.6	1.25	1.2	0.3 min.
GRM31BR73A332KW01L	DC1000	X7R (EIA)	3300pF ±10%	3.2	1.6	1.25	1.2	0.3 min.
GRM31BR73A472KW01L	DC1000	X7R (EIA)	4700pF ±10%	3.2	1.6	1.25	1.2	0.3 min.
GRM32QR73A682KW01L	DC1000	X7R (EIA)	6800pF ±10%	3.2	2.5	1.5	1.2	0.3 min.
GRM32QR73A103KW01L	DC1000	X7R (EIA)	10000pF ±10%	3.2	2.5	1.5	1.2	0.3 min.
GRM32DR73A153KW01L	DC1000	X7R (EIA)	15000pF ±10%	3.2	2.5	2.0	1.2	0.3 min.
GRM32DR73A223KW01L	DC1000	X7R (EIA)	22000pF ±10%	3.2	2.5	2.0	1.2	0.3 min.
GRM43DR73A333KW01L	DC1000	X7R (EIA)	33000pF ±10%	4.5	3.2	2.0	2.2	0.3 min.
GRM43DR73A473KW01L	DC1000	X7R (EIA)	47000pF ±10%	4.5	3.2	2.0	2.2	0.3 min.
GRM55DR73A104KW01L	DC1000	X7R (EIA)	0.10μF ±10%	5.7	5.0	2.0	3.2	0.3 min.

Operating Temperature Range: -55 to +125deg.
Only tape packaging is available.

△Note • This PDF catalog is downloaded from the website of Murata Manufacturing co., ltd. Therefore, it's specifications are subject to change or our products in it may be discontinued without advance notice. Please check with our sales representatives or product engineers before ordering.
• This PDF catalog has only typical specifications because there is no space for detailed specifications. Therefore, please approve our product specifications or transact the approval sheet for product specifications before ordering.

Monolithic Ceramic Capacitors for Medium Voltage

Only for LCD Backlight Inverter Circuit

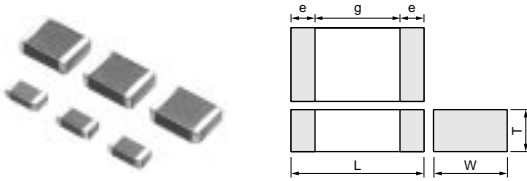

Part Number	Dimensions (mm)				
	L	W	T	e min.	g min.
GRM42A	4.5 ±0.3	2.0 ±0.2	1.0 +0, -0.3	0.3	2.9

Part Number	Rated Voltage (V)	TC Code (Standard)	Capacitance (pF)	Length L (mm)	Width W (mm)	Thickness T (mm)	Electrode g (min.) (mm)	Electrode e (mm)
GRM42A5C3F050DW01L	DC3150	C0G (EIA)	5.0 ±0.5pF	4.5	2.0	1.0	2.9	0.3 min.
GRM42A5C3F100JW01L	DC3150	C0G (EIA)	10 ±5%	4.5	2.0	1.0	2.9	0.3 min.
GRM42A5C3F120JW01L	DC3150	C0G (EIA)	12 ±5%	4.5	2.0	1.0	2.9	0.3 min.
GRM42A5C3F150JW01L	DC3150	C0G (EIA)	15 ±5%	4.5	2.0	1.0	2.9	0.3 min.
GRM42A5C3F180JW01L	DC3150	C0G (EIA)	18 ±5%	4.5	2.0	1.0	2.9	0.3 min.
GRM42A5C3F220JW01L	DC3150	C0G (EIA)	22 ±5%	4.5	2.0	1.0	2.9	0.3 min.
GRM42A5C3F270JW01L	DC3150	C0G (EIA)	27 ±5%	4.5	2.0	1.0	2.9	0.3 min.
GRM42A5C3F330JW01L	DC3150	C0G (EIA)	33 ±5%	4.5	2.0	1.0	2.9	0.3 min.
GRM42A5C3F390JW01L	DC3150	C0G (EIA)	39 ±5%	4.5	2.0	1.0	2.9	0.3 min.
GRM42A5C3F470JW01L	DC3150	C0G (EIA)	47 ±5%	4.5	2.0	1.0	2.9	0.3 min.

Operating Temperature Range: -55 to +125deg.
 These items are designed specifically for LCD backlight inverter circuit.
 Only tape packaging is available.

Monolithic Ceramic Capacitors for Medium Voltage

Only for Information Devices

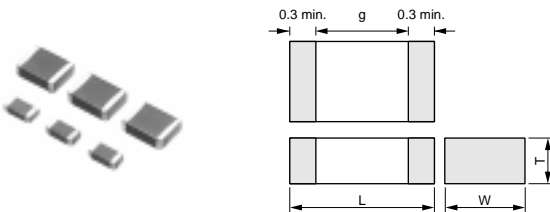

Part Number	Dimensions (mm)			
	L	W	T	g min.
GR442Q	4.5 ±0.3	2.0 ±0.2	1.5 +0, -0.3	2.5
GR443D	4.5 ±0.4	3.2 ±0.3	2.0 +0, -0.3	
GR443Q			1.5 +0, -0.3	
GR455D	5.7 ±0.4	5.0 ±0.4	2.0 +0, -0.3	3.2

Part Number	Rated Voltage (V)	TC Code (Standard)	Capacitance (pF)	Length L (mm)	Width W (mm)	Thickness T (mm)	Electrode g (min.) (mm)	Electrode e (mm)
GR442QR73D101KW01L	DC2000	X7R (EIA)	100 ±10%	4.5	2.0	1.5	2.5	0.3 min.
GR442QR73D121KW01L	DC2000	X7R (EIA)	120 ±10%	4.5	2.0	1.5	2.5	0.3 min.
GR442QR73D151KW01L	DC2000	X7R (EIA)	150 ±10%	4.5	2.0	1.5	2.5	0.3 min.
GR442QR73D181KW01L	DC2000	X7R (EIA)	180 ±10%	4.5	2.0	1.5	2.5	0.3 min.
GR442QR73D221KW01L	DC2000	X7R (EIA)	220 ±10%	4.5	2.0	1.5	2.5	0.3 min.
GR442QR73D271KW01L	DC2000	X7R (EIA)	270 ±10%	4.5	2.0	1.5	2.5	0.3 min.

Continued on the following page.

Note • This PDF catalog is downloaded from the website of Murata Manufacturing co., Ltd. Therefore, it's specifications are subject to change or our products in it may be discontinued without advance notice. Please check with our sales representatives or product engineers before ordering.
 • This PDF catalog has only typical specifications because there is no space for detailed specifications. Therefore, please approve our product specifications or transact the approval sheet for product specifications before ordering.

 Continued from the preceding page.

Part Number	Rated Voltage (V)	TC Code (Standard)	Capacitance (pF)	Length L (mm)	Width W (mm)	Thickness T (mm)	Electrode g (min.) (mm)	Electrode e (mm)
GR442QR73D331KW01L	DC2000	X7R (EIA)	330 ±10%	4.5	2.0	1.5	2.5	0.3 min.
GR442QR73D391KW01L	DC2000	X7R (EIA)	390 ±10%	4.5	2.0	1.5	2.5	0.3 min.
GR442QR73D471KW01L	DC2000	X7R (EIA)	470 ±10%	4.5	2.0	1.5	2.5	0.3 min.
GR442QR73D561KW01L	DC2000	X7R (EIA)	560 ±10%	4.5	2.0	1.5	2.5	0.3 min.
GR442QR73D681KW01L	DC2000	X7R (EIA)	680 ±10%	4.5	2.0	1.5	2.5	0.3 min.
GR442QR73D821KW01L	DC2000	X7R (EIA)	820 ±10%	4.5	2.0	1.5	2.5	0.3 min.
GR442QR73D102KW01L	DC2000	X7R (EIA)	1000 ±10%	4.5	2.0	1.5	2.5	0.3 min.
GR442QR73D122KW01L	DC2000	X7R (EIA)	1200 ±10%	4.5	2.0	1.5	2.5	0.3 min.
GR442QR73D152KW01L	DC2000	X7R (EIA)	1500 ±10%	4.5	2.0	1.5	2.5	0.3 min.
GR443QR73D182KW01L	DC2000	X7R (EIA)	1800 ±10%	4.5	3.2	1.5	2.5	0.3 min.
GR443QR73D222KW01L	DC2000	X7R (EIA)	2200 ±10%	4.5	3.2	1.5	2.5	0.3 min.
GR443QR73D272KW01L	DC2000	X7R (EIA)	2700 ±10%	4.5	3.2	1.5	2.5	0.3 min.
GR443QR73D332KW01L	DC2000	X7R (EIA)	3300 ±10%	4.5	3.2	1.5	2.5	0.3 min.
GR443QR73D392KW01L	DC2000	X7R (EIA)	3900 ±10%	4.5	3.2	1.5	2.5	0.3 min.
GR443DR73D472KW01L	DC2000	X7R (EIA)	4700 ±10%	4.5	3.2	2.0	2.5	0.3 min.
GR455DR73D103KW01L	DC2000	X7R (EIA)	10000 ±10%	5.7	5.0	2.0	3.2	0.3 min.

Operating Temperature Range: -55 to +125deg.

These items are designed specifically for telecommunication devices (IEEE802.3) in Ethernet LAN and primary-secondary coupling for DC-DC converter.

Only tape packaging is available.

Monolithic Ceramic Capacitors for Medium Voltage

Only for Camera Flash Circuit

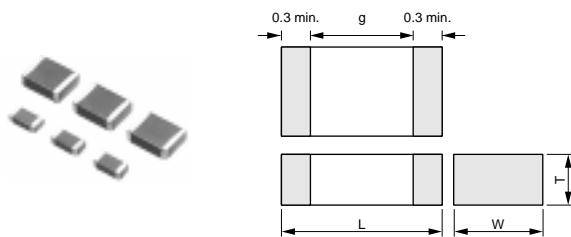

Part Number	Dimensions (mm)			
	L	W	T	g min.
GR731A	3.2 ±0.2	1.6 ±0.2	1.0 +0, -0.3	1.2
GR731B			1.25 +0, -0.3	
GR731C			1.6 ±0.2	

Part Number	Rated Voltage (V)	Capacitance (pF)	Length L (mm)	Width W (mm)	Thickness T (mm)	Electrode g (min.) (mm)	Electrode e (mm)
GR731AW0BB103KW01D	DC350	10000 ±10%	3.2	1.6	1.0	1.2	0.3 min.
GR731AW0BB153KW01D	DC350	15000 ±10%	3.2	1.6	1.0	1.2	0.3 min.
GR731BW0BB223KW01L	DC350	22000 ±10%	3.2	1.6	1.25	1.2	0.3 min.
GR731BW0BB333KW01L	DC350	33000 ±10%	3.2	1.6	1.25	1.2	0.3 min.
GR731CW0BB473KW03L	DC350	47000 ±10%	3.2	1.6	1.6	1.2	0.3 min.

Operating Temperature Range: -55 to +125deg.

These items are designed specifically for camera flash circuit.

Only tape packaging is available.

 Note • This PDF catalog is downloaded from the website of Murata Manufacturing co., ltd. Therefore, it's specifications are subject to change or our products in it may be discontinued without advance notice. Please check with our sales representatives or product engineers before ordering.
• This PDF catalog has only typical specifications because there is no space for detailed specifications. Therefore, please approve our product specifications or transact the approval sheet for product specifications before ordering.

Monolithic Ceramic Capacitors for Medium Voltage

for Automotive Low Dissipation Factor GCM Series (Power Train, Safety Equipment)

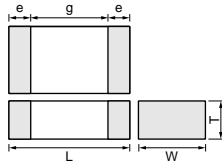

Part Number	Dimensions (mm)				
	L	W	T	e min.	g min.
GCM21A	2.0 ±0.2	1.25 ±0.2	1.0 +0, -0.3	0.3	0.7
GCM31A	3.2 ±0.2	1.6 ±0.2			1.5
GCM31B			1.25 +0, -0.3		
GCM32A	3.2 ±0.2	2.5 ±0.2	1.0 +0, -0.3		

Part Number	Rated Voltage (V)	TC Code (Standard)	Capacitance (pF)	Length L (mm)	Width W (mm)	Thickness T (mm)	Electrode g (min.) (mm)	Electrode e (mm)
GCM21A7U2E101JX01D	DC250	U2J (EIA)	100 ±5%	2.0	1.25	1.0	0.7	0.3 min.
GCM21A7U2E151JX01D	DC250	U2J (EIA)	150 ±5%	2.0	1.25	1.0	0.7	0.3 min.
GCM21A7U2E221JX01D	DC250	U2J (EIA)	220 ±5%	2.0	1.25	1.0	0.7	0.3 min.
GCM21A7U2E331JX01D	DC250	U2J (EIA)	330 ±5%	2.0	1.25	1.0	0.7	0.3 min.
GCM21A7U2E471JX01D	DC250	U2J (EIA)	470 ±5%	2.0	1.25	1.0	0.7	0.3 min.
GCM21A7U2E681JX01D	DC250	U2J (EIA)	680 ±5%	2.0	1.25	1.0	0.7	0.3 min.
GCM21A7U2E102JX01D	DC250	U2J (EIA)	1000 ±5%	2.0	1.25	1.0	0.7	0.3 min.
GCM21A7U2E152JX01D	DC250	U2J (EIA)	1500 ±5%	2.0	1.25	1.0	0.7	0.3 min.
GCM21A7U2E222JX01D	DC250	U2J (EIA)	2200 ±5%	2.0	1.25	1.0	0.7	0.3 min.
GCM31A7U2E332JX01D	DC250	U2J (EIA)	3300 ±5%	3.2	1.6	1.0	1.5	0.3 min.
GCM31A7U2E472JX01D	DC250	U2J (EIA)	4700 ±5%	3.2	1.6	1.0	1.5	0.3 min.
GCM31B7U2E682JX01L	DC250	U2J (EIA)	6800 ±5%	3.2	1.6	1.25	1.5	0.3 min.
GCM31B7U2E103JX01L	DC250	U2J (EIA)	10000 ±5%	3.2	1.6	1.25	1.5	0.3 min.
GCM31A7U2J100JX01D	DC630	U2J (EIA)	10 ±5%	3.2	1.6	1.0	1.5	0.3 min.
GCM31A7U2J150JX01D	DC630	U2J (EIA)	15 ±5%	3.2	1.6	1.0	1.5	0.3 min.
GCM31A7U2J220JX01D	DC630	U2J (EIA)	22 ±5%	3.2	1.6	1.0	1.5	0.3 min.
GCM31A7U2J330JX01D	DC630	U2J (EIA)	33 ±5%	3.2	1.6	1.0	1.5	0.3 min.
GCM31A7U2J470JX01D	DC630	U2J (EIA)	47 ±5%	3.2	1.6	1.0	1.5	0.3 min.
GCM31A7U2J680JX01D	DC630	U2J (EIA)	68 ±5%	3.2	1.6	1.0	1.5	0.3 min.
GCM31A7U2J101JX01D	DC630	U2J (EIA)	100 ±5%	3.2	1.6	1.0	1.5	0.3 min.
GCM31A7U2J151JX01D	DC630	U2J (EIA)	150 ±5%	3.2	1.6	1.0	1.5	0.3 min.
GCM31A7U2J221JX01D	DC630	U2J (EIA)	220 ±5%	3.2	1.6	1.0	1.5	0.3 min.
GCM31A7U2J331JX01D	DC630	U2J (EIA)	330 ±5%	3.2	1.6	1.0	1.5	0.3 min.
GCM31A7U2J471JX01D	DC630	U2J (EIA)	470 ±5%	3.2	1.6	1.0	1.5	0.3 min.
GCM31A7U2J681JX01D	DC630	U2J (EIA)	680 ±5%	3.2	1.6	1.0	1.5	0.3 min.
GCM31A7U2J102JX01D	DC630	U2J (EIA)	1000 ±5%	3.2	1.6	1.0	1.5	0.3 min.
GCM32A7U2J152JX01D	DC630	U2J (EIA)	1500 ±5%	3.2	2.5	1.0	1.5	0.3 min.
GCM32A7U2J222JX01D	DC630	U2J (EIA)	2200 ±5%	3.2	2.5	1.0	1.5	0.3 min.

Operating Temperature Range: -55 to +125deg.

Only tape packaging is available.

Monolithic Ceramic Capacitors Safety Standard Certified

AC250V Type (Which Meet Japanese Law)

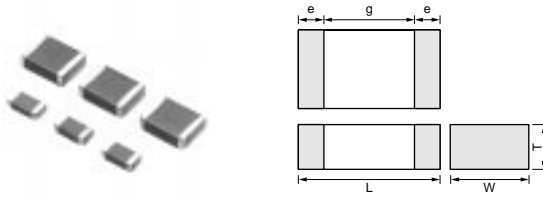

Part Number	Dimensions (mm)				
	L	W	T	e min.	g min.
GA242Q	4.5 ±0.3	2.0 ±0.2	1.5 +0, -0.3	0.3	2.5
GA243D	4.5 ±0.4	3.2 ±0.3	2.0 +0, -0.3		
GA243Q			1.5 +0, -0.3		
GA255D	5.7 ±0.4	5.0 ±0.4	2.0 +0, -0.3		

Part Number	Rated Voltage (V)	TC Code (Standard)	Capacitance	Length L (mm)	Width W (mm)	Thickness T (mm)	Electrode g (min.) (mm)	Electrode e (mm)
GA242QR7E2471MW01L	AC250 (r.m.s.)	X7R (EIA)	470pF ±20%	4.5	2.0	1.5	2.5	0.3 min.
GA242QR7E2102MW01L	AC250 (r.m.s.)	X7R (EIA)	1000pF ±20%	4.5	2.0	1.5	2.5	0.3 min.
GA243QR7E2222MW01L	AC250 (r.m.s.)	X7R (EIA)	2200pF ±20%	4.5	3.2	1.5	2.5	0.3 min.
GA243QR7E2332MW01L	AC250 (r.m.s.)	X7R (EIA)	3300pF ±20%	4.5	3.2	1.5	2.5	0.3 min.
GA243DR7E2472MW01L	AC250 (r.m.s.)	X7R (EIA)	4700pF ±20%	4.5	3.2	2.0	2.5	0.3 min.
GA243QR7E2103MW01L	AC250 (r.m.s.)	X7R (EIA)	10000pF ±20%	4.5	3.2	1.5	2.5	0.3 min.
GA243QR7E2223MW01L	AC250 (r.m.s.)	X7R (EIA)	22000pF ±20%	4.5	3.2	1.5	2.5	0.3 min.
GA243DR7E2473MW01L	AC250 (r.m.s.)	X7R (EIA)	47000pF ±20%	4.5	3.2	2.0	2.5	0.3 min.
GA255DR7E2104MW01L	AC250 (r.m.s.)	X7R (EIA)	0.10μF ±20%	5.7	5.0	2.0	3.2	0.3 min.

Operating Temperature Range: -55 to +125deg.

Dielectric Strength: Nominal Capacitance C>=10000pF AC575V (r.m.s), 60±1s. Nominal Capacitance C<10000pF AC1500V (r.m.s.) 60±1s.

Only tape packaging is available.

Monolithic Ceramic Capacitors Safety Standard Certified

Type GC (UL, IEC60384-14 Class X1/Y2)

Standard Certification

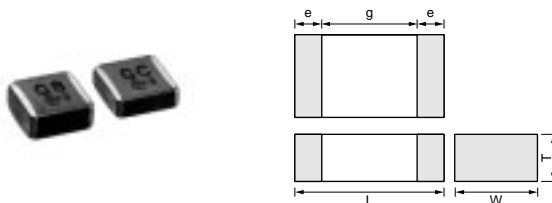

Part Number	Dimensions (mm)				
	L	W	T	e min.	g min.
GA355D	5.7 ±0.4	5.0 ±0.4	2.0 ±0.3	0.3	4.0

	Standard No.	Class	Rated Voltage
UL	UL1414	Line By-pass	AC250V (r.m.s.)
VDE	IEC 60384-14 EN 60384-14	X1, Y2	
BSI	EN 60065 (14.2) IEC 60384-14 EN 60384-14		
SEMKO	IEC 60384-14 EN 60384-14		
ESTI	EN 60065 IEC 60384-14		

Part Number	Rated Voltage (V)	TC Code (Standard)	Capacitance (pF)	Length L (mm)	Width W (mm)	Thickness T (mm)	Electrode g (min.) (mm)	Electrode e (mm)
GA355DR7GC101KY02L	AC250 (r.m.s.)	X7R (EIA)	100 ±10%	5.7	5.0	2.0	4.0	0.3 min.
GA355DR7GC151KY02L	AC250 (r.m.s.)	X7R (EIA)	150 ±10%	5.7	5.0	2.0	4.0	0.3 min.
GA355DR7GC221KY02L	AC250 (r.m.s.)	X7R (EIA)	220 ±10%	5.7	5.0	2.0	4.0	0.3 min.
GA355DR7GC331KY02L	AC250 (r.m.s.)	X7R (EIA)	330 ±10%	5.7	5.0	2.0	4.0	0.3 min.

Operating Temperature Range: -55 to +125deg. (UL std.: -55 to +85deg.)

Dielectric Strength: AC1500V(r.m.s.), 60±1s.

Only tape packaging is available.

△Note • This PDF catalog is downloaded from the website of Murata Manufacturing co., ltd. Therefore, it's specifications are subject to change or our products in it may be discontinued without advance notice. Please check with our sales representatives or product engineers before ordering.
• This PDF catalog has only typical specifications because there is no space for detailed specifications. Therefore, please approve our product specifications or transact the approval sheet for product specifications before ordering.

Monolithic Ceramic Capacitors Safety Standard Certified

Type GD (IEC60384-14 Class Y3)

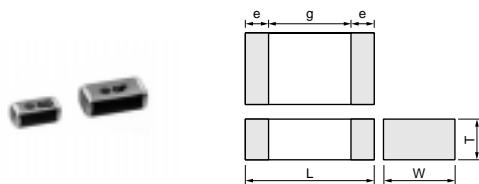

Standard Certification

	Standard No.	Class	Rated Voltage
UL	UL 60950-1	Y3	AC250V(r.m.s.)
SEMKO	IEC 60384-14 EN 60384-14		

Applications

Size	Switching power supplies	Communication network devices such as a modem
4.5×3.2mm and under	—	◎

Part Number	Dimensions (mm)				
	L	W	T	e min.	g min.
GA342A	4.5 ±0.3	2.0 ±0.2	1.0 +0, -0.3	0.3	2.5
GA342D			2.0 ±0.3		
GA342Q			1.5 +0, -0.3		
GA343D	4.5 ±0.4	3.2 ±0.3	2.0 +0, -0.3		
GA343Q			1.5 +0, -0.3		

Part Number	Rated Voltage (V)	TC Code (Standard)	Capacitance (pF)	Length L (mm)	Width W (mm)	Thickness T (mm)	Electrode g (min.) (mm)	Electrode e (mm)
GA342D1XGD100JY02L	AC250 (r.m.s.)	SL (JIS)	10 ±5%	4.5	2.0	2.0	2.5	0.3 min.
GA342D1XGD120JY02L	AC250 (r.m.s.)	SL (JIS)	12 ±5%	4.5	2.0	2.0	2.5	0.3 min.
GA342D1XGD150JY02L	AC250 (r.m.s.)	SL (JIS)	15 ±5%	4.5	2.0	2.0	2.5	0.3 min.
GA342D1XGD180JY02L	AC250 (r.m.s.)	SL (JIS)	18 ±5%	4.5	2.0	2.0	2.5	0.3 min.
GA342D1XGD220JY02L	AC250 (r.m.s.)	SL (JIS)	22 ±5%	4.5	2.0	2.0	2.5	0.3 min.
GA342A1XGD270JW31L	AC250 (r.m.s.)	SL (JIS)	27 ±5%	4.5	2.0	1.0	2.5	0.3 min.
GA342A1XGD330JW31L	AC250 (r.m.s.)	SL (JIS)	33 ±5%	4.5	2.0	1.0	2.5	0.3 min.
GA342A1XGD390JW31L	AC250 (r.m.s.)	SL (JIS)	39 ±5%	4.5	2.0	1.0	2.5	0.3 min.
GA342A1XGD470JW31L	AC250 (r.m.s.)	SL (JIS)	47 ±5%	4.5	2.0	1.0	2.5	0.3 min.
GA342A1XGD560JW31L	AC250 (r.m.s.)	SL (JIS)	56 ±5%	4.5	2.0	1.0	2.5	0.3 min.
GA342A1XGD680JW31L	AC250 (r.m.s.)	SL (JIS)	68 ±5%	4.5	2.0	1.0	2.5	0.3 min.
GA342A1XGD820JW31L	AC250 (r.m.s.)	SL (JIS)	82 ±5%	4.5	2.0	1.0	2.5	0.3 min.
GA342QR7GD101KW01L	AC250 (r.m.s.)	X7R (EIA)	100 ±10%	4.5	2.0	1.5	2.5	0.3 min.
GA342QR7GD151KW01L	AC250 (r.m.s.)	X7R (EIA)	150 ±10%	4.5	2.0	1.5	2.5	0.3 min.
GA342QR7GD221KW01L	AC250 (r.m.s.)	X7R (EIA)	220 ±10%	4.5	2.0	1.5	2.5	0.3 min.
GA342QR7GD331KW01L	AC250 (r.m.s.)	X7R (EIA)	330 ±10%	4.5	2.0	1.5	2.5	0.3 min.
GA342QR7GD471KW01L	AC250 (r.m.s.)	X7R (EIA)	470 ±10%	4.5	2.0	1.5	2.5	0.3 min.
GA342QR7GD681KW01L	AC250 (r.m.s.)	X7R (EIA)	680 ±10%	4.5	2.0	1.5	2.5	0.3 min.
GA342QR7GD102KW01L	AC250 (r.m.s.)	X7R (EIA)	1000 ±10%	4.5	2.0	1.5	2.5	0.3 min.
GA342QR7GD152KW01L	AC250 (r.m.s.)	X7R (EIA)	1500 ±10%	4.5	2.0	1.5	2.5	0.3 min.
GA343QR7GD182KW01L	AC250 (r.m.s.)	X7R (EIA)	1800 ±10%	4.5	3.2	1.5	2.5	0.3 min.
GA343QR7GD222KW01L	AC250 (r.m.s.)	X7R (EIA)	2200 ±10%	4.5	3.2	1.5	2.5	0.3 min.
GA343DR7GD472KW01L	AC250 (r.m.s.)	X7R (EIA)	4700 ±10%	4.5	3.2	2.0	2.5	0.3 min.

Operating Temperature Range: -55 to +125deg.

Dielectric Strength: AC1500V(r.m.s.), 60±1s.

Only tape packaging is available.

Monolithic Ceramic Capacitors Safety Standard Certified

Type GF (IEC60384-14 Class Y2, X1/Y2)

Standard Certification

	Standard No.	Class	Status of Recognition		Rated Voltage
			Size : 4.5x2.0mm	Size : 5.7x2.8mm and over	
UL	UL1414	X1, Y2	—	⊙	AC250V (r.m.s.)
	UL 60950-1	—	⊙	—	
VDE	IEC 60384-14	X1, Y2	—	⊙	(r.m.s.)
SEMKO	EN 60384-14	Y2	⊙	⊙	

Applications

Size	Switching power supplies	Communication network devices such as a modem
4.5x2.0mm	—	⊙
5.7x2.8mm and over	⊙	⊙

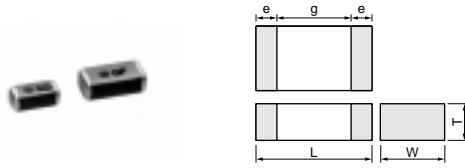

Part Number	Dimensions (mm)				
	L	W	T	e min.	g min.
GA342A	4.5 ±0.3	2.0 ±0.2	1.0 +0, -0.3	0.3	2.5
GA342D			2.0 ±0.2*		
GA342Q			1.5 +0, -0.3		
GA352Q	5.7 ±0.4	2.8 ±0.3	1.5 +0, -0.3	0.3	4.0
GA355D		5.0 ±0.4	2.0 +0, -0.3		
GA355Q		5.0 ±0.4	1.5 +0, -0.3		

* GA342D1X : 2.0±0.3

Part Number	Rated Voltage (V)	TC Code (Standard)	Capacitance (pF)	Length L (mm)	Width W (mm)	Thickness T (mm)	Electrode g (min.) (mm)	Electrode e (mm)
GA342D1XGF100JY02L	AC250 (r.m.s.)	SL (JIS)	10 ±5%	4.5	2.0	2.0	2.5	0.3 min.
GA342D1XGF120JY02L	AC250 (r.m.s.)	SL (JIS)	12 ±5%	4.5	2.0	2.0	2.5	0.3 min.
GA342D1XGF150JY02L	AC250 (r.m.s.)	SL (JIS)	15 ±5%	4.5	2.0	2.0	2.5	0.3 min.
GA342D1XGF180JY02L	AC250 (r.m.s.)	SL (JIS)	18 ±5%	4.5	2.0	2.0	2.5	0.3 min.
GA342D1XGF220JY02L	AC250 (r.m.s.)	SL (JIS)	22 ±5%	4.5	2.0	2.0	2.5	0.3 min.
GA342A1XGF270JW31L	AC250 (r.m.s.)	SL (JIS)	27 ±5%	4.5	2.0	1.0	2.5	0.3 min.
GA342A1XGF330JW31L	AC250 (r.m.s.)	SL (JIS)	33 ±5%	4.5	2.0	1.0	2.5	0.3 min.
GA342A1XGF390JW31L	AC250 (r.m.s.)	SL (JIS)	39 ±5%	4.5	2.0	1.0	2.5	0.3 min.
GA342A1XGF470JW31L	AC250 (r.m.s.)	SL (JIS)	47 ±5%	4.5	2.0	1.0	2.5	0.3 min.
GA342A1XGF560JW31L	AC250 (r.m.s.)	SL (JIS)	56 ±5%	4.5	2.0	1.0	2.5	0.3 min.
GA342A1XGF680JW31L	AC250 (r.m.s.)	SL (JIS)	68 ±5%	4.5	2.0	1.0	2.5	0.3 min.
GA342A1XGF820JW31L	AC250 (r.m.s.)	SL (JIS)	82 ±5%	4.5	2.0	1.0	2.5	0.3 min.
GA342QR7GF101KW01L	AC250 (r.m.s.)	X7R (EIA)	100 ±10%	4.5	2.0	1.5	2.5	0.3 min.
GA342QR7GF151KW01L	AC250 (r.m.s.)	X7R (EIA)	150 ±10%	4.5	2.0	1.5	2.5	0.3 min.
GA342DR7GF221KW02L	AC250 (r.m.s.)	X7R (EIA)	220 ±10%	4.5	2.0	2.0	2.5	0.3 min.
GA342DR7GF331KW02L	AC250 (r.m.s.)	X7R (EIA)	330 ±10%	4.5	2.0	2.0	2.5	0.3 min.
GA342QR7GF471KW01L	AC250 (r.m.s.)	X7R (EIA)	470 ±10%	4.5	2.0	1.5	2.5	0.3 min.
GA352QR7GF471KW01L	AC250 (r.m.s.)	X7R (EIA)	470 ±10%	5.7	2.8	1.5	4.0	0.3 min.
GA342QR7GF681KW01L	AC250 (r.m.s.)	X7R (EIA)	680 ±10%	4.5	2.0	1.5	2.5	0.3 min.
GA352QR7GF681KW01L	AC250 (r.m.s.)	X7R (EIA)	680 ±10%	5.7	2.8	1.5	4.0	0.3 min.
GA342DR7GF102KW02L	AC250 (r.m.s.)	X7R (EIA)	1000 ±10%	4.5	2.0	2.0	2.5	0.3 min.
GA352QR7GF102KW01L	AC250 (r.m.s.)	X7R (EIA)	1000 ±10%	5.7	2.8	1.5	4.0	0.3 min.
GA352QR7GF152KW01L	AC250 (r.m.s.)	X7R (EIA)	1500 ±10%	5.7	2.8	1.5	4.0	0.3 min.
GA355QR7GF182KW01L	AC250 (r.m.s.)	X7R (EIA)	1800 ±10%	5.7	5.0	1.5	4.0	0.3 min.
GA355QR7GF222KW01L	AC250 (r.m.s.)	X7R (EIA)	2200 ±10%	5.7	5.0	1.5	4.0	0.3 min.
GA355QR7GF332KW01L	AC250 (r.m.s.)	X7R (EIA)	3300 ±10%	5.7	5.0	1.5	4.0	0.3 min.
GA355DR7GF472KW01L	AC250 (r.m.s.)	X7R (EIA)	4700 ±10%	5.7	5.0	2.0	4.0	0.3 min.

Operating Temperature Range: -55 to +125deg.

Dielectric Strength: AC1500V(r.m.s.), 60±1s.

Only tape packaging is available.

△Note • This PDF catalog is downloaded from the website of Murata Manufacturing co., ltd. Therefore, it's specifications are subject to change or our products in it may be discontinued without advance notice. Please check with our sales representatives or product engineers before ordering.
 • This PDF catalog has only typical specifications because there is no space for detailed specifications. Therefore, please approve our product specifications or transact the approval sheet for product specifications before ordering.

Monolithic Ceramic Capacitors Safety Standard Certified

Type GB (IEC60384-14 Class X2)

 1
Capacitors

Standard Certification

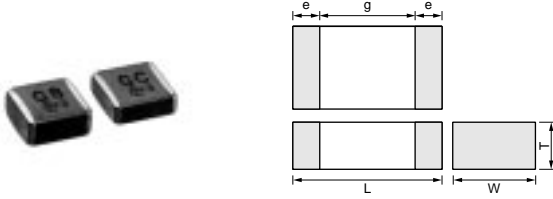

Part Number	Dimensions (mm)				
	L	W	T	e min.	g min.
GA355Q	5.7 ±0.4	5.0 ±0.4	1.5 +0,-0.3	0.3	3.0
GA355D			2.0 +0,-0.3		
GA355E			2.5 +0,-0.3		
GA355X			2.9 +0,-0.4		

	Standard No.	Class	Rated Voltage
VDE	IEC 60384-14 EN 60384-14	X2	AC250V (r.m.s.)
SEMKO			
ESTI			

Part Number	Rated Voltage (V)	TC Code (Standard)	Capacitance (pF)	Length L (mm)	Width W (mm)	Thickness T (mm)	Electrode g (min.) (mm)	Electrode e (mm)
GA355QR7GB103KW01L	AC250 (r.m.s.)	X7R (EIA)	10000 ±10%	5.7	5.0	1.5	3.0	0.3 min.
GA355QR7GB153KW01L	AC250 (r.m.s.)	X7R (EIA)	15000 ±10%	5.7	5.0	1.5	3.0	0.3 min.
GA355DR7GB223KW01L	AC250 (r.m.s.)	X7R (EIA)	22000 ±10%	5.7	5.0	2.0	3.0	0.3 min.
GA355ER7GB333KW01L	AC250 (r.m.s.)	X7R (EIA)	33000 ±10%	5.7	5.0	2.5	3.0	0.3 min.
GA355ER7GB473KW01L	AC250 (r.m.s.)	X7R (EIA)	47000 ±10%	5.7	5.0	2.5	3.0	0.3 min.
GA355XR7GB563KW06L	AC250 (r.m.s.)	X7R (EIA)	56000 ±10%	5.7	5.0	2.9	3.0	0.3 min.

Operating Temperature Range: -55 to +125deg.

Dielectric Strength: DC1075V, 60±1s.

Only tape packaging is available.

Monolithic Ceramic Capacitors (Lead Type)

RPE Series (DC25V-DC100V)

● Part number configuration (Please see page 22 for details)

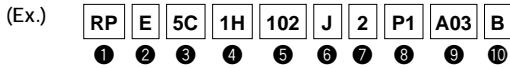

● Dimensions

Dimensions and Lead Style Code	Dimensions (mm)					
	L	W	W1	T	F	d
2P1/2S1/2S2	5.0	3.5	5.0	See the individual product specifications	2.5	0.5
2K1/2M1/2M2	5.0	3.5	5.0		5.0	0.5
3P1/3S1/3S2	5.0	4.5	6.3		2.5	0.5
3K1/3M1/3M2	5.0	4.5	6.3		5.0	0.5
4K1/4M1/4M2	7.5	5.0	7.0		5.0	0.5
5B1/5E1/5E2	7.5	7.5	-		5.0	0.5
6B1/6E1/6E2	10.0	10.0	-		5.0	0.5
7C1	12.5	12.5	-		10.0	0.5
8K1/8M1/8M2	7.5	5.5	8.0		5.0	0.5
TB1/TE1/TE2	10.0	8.5	-		5.0	0.5

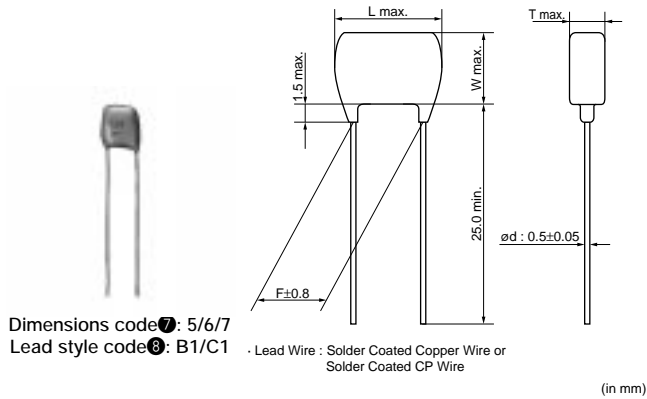
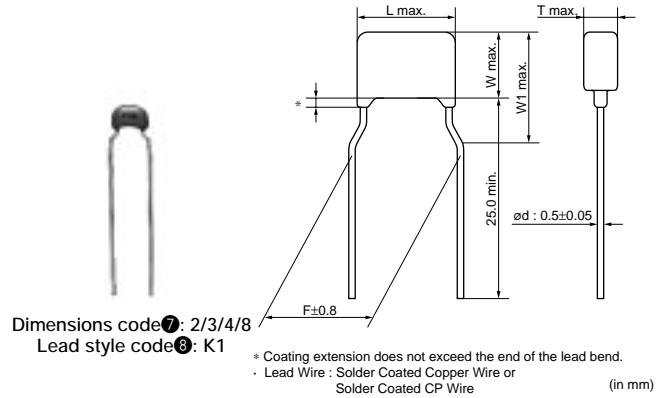
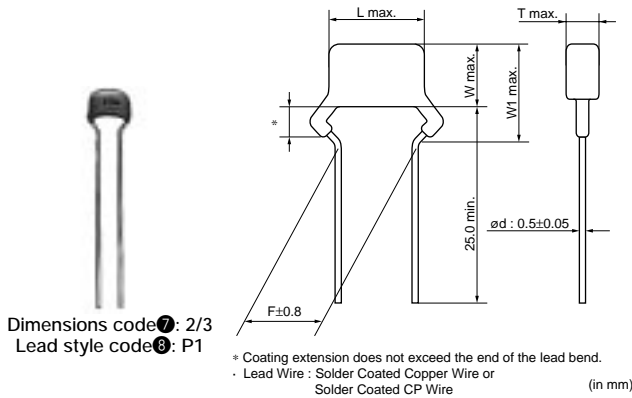

● Temperature Compensating Type

Part Number	TC	Rated Voltage (Vdc)	Capacitance (pF)	Dimensions LxW (mm)	Dimension T (mm)	Lead Space F (mm)	Lead Style Code Bulk	Lead Style Code Taping (1)	Lead Style Code Taping (2)
RPE5C1H1R0C2□□B03□	C0G	50	1.0 ±0.25pF	5.0 x 3.5	2.5	2.5	P1	S1	S2
RPE5C1H1R0C2□□B03□	C0G	50	1.0 ±0.25pF	5.0 x 3.5	2.5	5.0	K1	M1	M2
RPE5C1H2R0C2□□B03□	C0G	50	2.0 ±0.25pF	5.0 x 3.5	2.5	2.5	P1	S1	S2
RPE5C1H2R0C2□□B03□	C0G	50	2.0 ±0.25pF	5.0 x 3.5	2.5	5.0	K1	M1	M2
RPE5C1H3R0C2□□B03□	C0G	50	3.0 ±0.25pF	5.0 x 3.5	2.5	2.5	P1	S1	S2
RPE5C1H3R0C2□□B03□	C0G	50	3.0 ±0.25pF	5.0 x 3.5	2.5	5.0	K1	M1	M2
RPE5C1H4R0C2□□B03□	C0G	50	4.0 ±0.25pF	5.0 x 3.5	2.5	2.5	P1	S1	S2
RPE5C1H4R0C2□□B03□	C0G	50	4.0 ±0.25pF	5.0 x 3.5	2.5	5.0	K1	M1	M2
RPE5C1H5R0C2□□B03□	C0G	50	5.0 ±0.25pF	5.0 x 3.5	2.5	2.5	P1	S1	S2
RPE5C1H5R0C2□□B03□	C0G	50	5.0 ±0.25pF	5.0 x 3.5	2.5	5.0	K1	M1	M2
RPE5C1H6R0D2□□B03□	C0G	50	6.0 ±0.5pF	5.0 x 3.5	2.5	2.5	P1	S1	S2
RPE5C1H6R0D2□□B03□	C0G	50	6.0 ±0.5pF	5.0 x 3.5	2.5	5.0	K1	M1	M2

Continued on the following page. ↗

△Note • This PDF catalog is downloaded from the website of Murata Manufacturing co., ltd. Therefore, it's specifications are subject to change or our products in it may be discontinued without advance notice. Please check with our sales representatives or product engineers before ordering.
• This PDF catalog has only typical specifications because there is no space for detailed specifications. Therefore, please approve our product specifications or transact the approval sheet for product specifications before ordering.

Continued from the preceding page.

Part Number	TC	Rated Voltage (Vdc)	Capacitance (pF)	Dimensions LxW (mm)	Dimension T (mm)	Lead Space F (mm)	Lead Style Code Bulk	Lead Style Code Taping (1)	Lead Style Code Taping (2)
RPE5C1H7R0D2□□Z03□	C0G	50	7.0 ±0.5pF	5.0 x 3.5	2.5	2.5	P1	S1	S2
RPE5C1H7R0D2□□Z03□	C0G	50	7.0 ±0.5pF	5.0 x 3.5	2.5	5.0	K1	M1	M2
RPE5C1H8R0D2□□Z03□	C0G	50	8.0 ±0.5pF	5.0 x 3.5	2.5	2.5	P1	S1	S2
RPE5C1H8R0D2□□Z03□	C0G	50	8.0 ±0.5pF	5.0 x 3.5	2.5	5.0	K1	M1	M2
RPE5C1H9R0D2□□Z03□	C0G	50	9.0 ±0.5pF	5.0 x 3.5	2.5	2.5	P1	S1	S2
RPE5C1H9R0D2□□Z03□	C0G	50	9.0 ±0.5pF	5.0 x 3.5	2.5	5.0	K1	M1	M2
RPE5C1H100J2□□Z03□	C0G	50	10 ±5%	5.0 x 3.5	2.5	2.5	P1	S1	S2
RPE5C1H100J2□□Z03□	C0G	50	10 ±5%	5.0 x 3.5	2.5	5.0	K1	M1	M2
RPE5C1H120J2□□Z03□	C0G	50	12 ±5%	5.0 x 3.5	2.5	2.5	P1	S1	S2
RPE5C1H120J2□□Z03□	C0G	50	12 ±5%	5.0 x 3.5	2.5	5.0	K1	M1	M2
RPE5C1H150J2□□Z03□	C0G	50	15 ±5%	5.0 x 3.5	2.5	2.5	P1	S1	S2
RPE5C1H150J2□□Z03□	C0G	50	15 ±5%	5.0 x 3.5	2.5	5.0	K1	M1	M2
RPE5C1H180J2□□Z03□	C0G	50	18 ±5%	5.0 x 3.5	2.5	2.5	P1	S1	S2
RPE5C1H180J2□□Z03□	C0G	50	18 ±5%	5.0 x 3.5	2.5	5.0	K1	M1	M2
RPE5C1H220J2□□Z03□	C0G	50	22 ±5%	5.0 x 3.5	2.5	2.5	P1	S1	S2
RPE5C1H220J2□□Z03□	C0G	50	22 ±5%	5.0 x 3.5	2.5	5.0	K1	M1	M2
RPE5C1H270J2□□Z03□	C0G	50	27 ±5%	5.0 x 3.5	2.5	2.5	P1	S1	S2
RPE5C1H270J2□□Z03□	C0G	50	27 ±5%	5.0 x 3.5	2.5	5.0	K1	M1	M2
RPE5C1H330J2□□Z03□	C0G	50	33 ±5%	5.0 x 3.5	2.5	2.5	P1	S1	S2
RPE5C1H330J2□□Z03□	C0G	50	33 ±5%	5.0 x 3.5	2.5	5.0	K1	M1	M2
RPE5C1H390J2□□Z03□	C0G	50	39 ±5%	5.0 x 3.5	2.5	2.5	P1	S1	S2
RPE5C1H390J2□□Z03□	C0G	50	39 ±5%	5.0 x 3.5	2.5	5.0	K1	M1	M2
RPE5C1H470J2□□Z03□	C0G	50	47 ±5%	5.0 x 3.5	2.5	2.5	P1	S1	S2
RPE5C1H470J2□□Z03□	C0G	50	47 ±5%	5.0 x 3.5	2.5	5.0	K1	M1	M2
RPE5C1H560J2□□Z03□	C0G	50	56 ±5%	5.0 x 3.5	2.5	2.5	P1	S1	S2
RPE5C1H560J2□□Z03□	C0G	50	56 ±5%	5.0 x 3.5	2.5	5.0	K1	M1	M2
RPE5C1H680J2□□Z03□	C0G	50	68 ±5%	5.0 x 3.5	2.5	2.5	P1	S1	S2
RPE5C1H680J2□□Z03□	C0G	50	68 ±5%	5.0 x 3.5	2.5	5.0	K1	M1	M2
RPE5C1H820J2□□Z03□	C0G	50	82 ±5%	5.0 x 3.5	2.5	2.5	P1	S1	S2
RPE5C1H820J2□□Z03□	C0G	50	82 ±5%	5.0 x 3.5	2.5	5.0	K1	M1	M2
RPE5C1H101J2□□A03□	C0G	50	100 ±5%	5.0 x 3.5	2.5	2.5	P1	S1	S2
RPE5C1H101J2□□A03□	C0G	50	100 ±5%	5.0 x 3.5	2.5	5.0	K1	M1	M2
RPE5C1H121J2□□A03□	C0G	50	120 ±5%	5.0 x 3.5	2.5	2.5	P1	S1	S2
RPE5C1H121J2□□A03□	C0G	50	120 ±5%	5.0 x 3.5	2.5	5.0	K1	M1	M2
RPE5C1H151J2□□A03□	C0G	50	150 ±5%	5.0 x 3.5	2.5	2.5	P1	S1	S2
RPE5C1H151J2□□A03□	C0G	50	150 ±5%	5.0 x 3.5	2.5	5.0	K1	M1	M2
RPE5C1H181J2□□A03□	C0G	50	180 ±5%	5.0 x 3.5	2.5	2.5	P1	S1	S2
RPE5C1H181J2□□A03□	C0G	50	180 ±5%	5.0 x 3.5	2.5	5.0	K1	M1	M2
RPE5C1H221J2□□A03□	C0G	50	220 ±5%	5.0 x 3.5	2.5	2.5	P1	S1	S2
RPE5C1H221J2□□A03□	C0G	50	220 ±5%	5.0 x 3.5	2.5	5.0	K1	M1	M2
RPE5C1H271J2□□A03□	C0G	50	270 ±5%	5.0 x 3.5	2.5	2.5	P1	S1	S2
RPE5C1H271J2□□A03□	C0G	50	270 ±5%	5.0 x 3.5	2.5	5.0	K1	M1	M2
RPE5C1H331J2□□A03□	C0G	50	330 ±5%	5.0 x 3.5	2.5	2.5	P1	S1	S2
RPE5C1H331J2□□A03□	C0G	50	330 ±5%	5.0 x 3.5	2.5	5.0	K1	M1	M2
RPE5C1H391J2□□A03□	C0G	50	390 ±5%	5.0 x 3.5	2.5	2.5	P1	S1	S2
RPE5C1H391J2□□A03□	C0G	50	390 ±5%	5.0 x 3.5	2.5	5.0	K1	M1	M2
RPE5C1H471J2□□A03□	C0G	50	470 ±5%	5.0 x 3.5	2.5	2.5	P1	S1	S2
RPE5C1H471J2□□A03□	C0G	50	470 ±5%	5.0 x 3.5	2.5	5.0	K1	M1	M2
RPE5C1H561J2□□A03□	C0G	50	560 ±5%	5.0 x 3.5	2.5	2.5	P1	S1	S2
RPE5C1H561J2□□A03□	C0G	50	560 ±5%	5.0 x 3.5	2.5	5.0	K1	M1	M2
RPE5C1H681J2□□A03□	C0G	50	680 ±5%	5.0 x 3.5	2.5	2.5	P1	S1	S2
RPE5C1H681J2□□A03□	C0G	50	680 ±5%	5.0 x 3.5	2.5	5.0	K1	M1	M2
RPE5C1H821J2□□A03□	C0G	50	820 ±5%	5.0 x 3.5	2.5	2.5	P1	S1	S2
RPE5C1H821J2□□A03□	C0G	50	820 ±5%	5.0 x 3.5	2.5	5.0	K1	M1	M2
RPE5C1H102J2□□A03□	C0G	50	1000 ±5%	5.0 x 3.5	2.5	2.5	P1	S1	S2

Continued on the following page.

Continued from the preceding page.

Part Number	TC	Rated Voltage (Vdc)	Capacitance (pF)	Dimensions LxW (mm)	Dimension T (mm)	Lead Space F (mm)	Lead Style Code Bulk	Lead Style Code Taping (1)	Lead Style Code Taping (2)
RPE5C1H102J2□□A03□	C0G	50	1000 ±5%	5.0 x 3.5	2.5	5.0	K1	M1	M2
RPE5C1H122J2□□A03□	C0G	50	1200 ±5%	5.0 x 3.5	3.15	2.5	P1	S1	S2
RPE5C1H122J2□□A03□	C0G	50	1200 ±5%	5.0 x 3.5	3.15	5.0	K1	M1	M2
RPE5C1H152J2□□A03□	C0G	50	1500 ±5%	5.0 x 3.5	3.15	2.5	P1	S1	S2
RPE5C1H152J2□□A03□	C0G	50	1500 ±5%	5.0 x 3.5	3.15	5.0	K1	M1	M2
RPE5C1H182J2□□C03□	C0G	50	1800 ±5%	5.0 x 3.5	3.15	2.5	P1	S1	S2
RPE5C1H182J2□□A03□	C0G	50	1800 ±5%	5.0 x 3.5	3.15	5.0	K1	M1	M2
RPE5C1H222J2□□C03□	C0G	50	2200 ±5%	5.0 x 3.5	3.15	2.5	P1	S1	S2
RPE5C1H222J2□□A03□	C0G	50	2200 ±5%	5.0 x 3.5	3.15	5.0	K1	M1	M2
RPE5C1H272J2□□C03□	C0G	50	2700 ±5%	5.0 x 3.5	3.15	2.5	P1	S1	S2
RPE5C1H272J2□□A03□	C0G	50	2700 ±5%	5.0 x 3.5	3.15	5.0	K1	M1	M2
RPE5C1H332J2□□C03□	C0G	50	3300 ±5%	5.0 x 3.5	3.15	2.5	P1	S1	S2
RPE5C1H332J2□□A03□	C0G	50	3300 ±5%	5.0 x 3.5	3.15	5.0	K1	M1	M2
RPE5C1H392J2□□C03□	C0G	50	3900 ±5%	5.0 x 3.5	3.15	2.5	P1	S1	S2
RPE5C1H392J2□□A03□	C0G	50	3900 ±5%	5.0 x 3.5	3.15	5.0	K1	M1	M2
RPE5C1H472J2□□C03□	C0G	50	4700 ±5%	5.0 x 3.5	3.15	2.5	P1	S1	S2
RPE5C1H472J2□□A03□	C0G	50	4700 ±5%	5.0 x 3.5	3.15	5.0	K1	M1	M2
RPE5C1H562J2□□C03□	C0G	50	5600 ±5%	5.0 x 3.5	3.15	2.5	P1	S1	S2
RPE5C1H562J2□□A03□	C0G	50	5600 ±5%	5.0 x 3.5	3.15	5.0	K1	M1	M2
RPE5C1H682J2□□C03□	C0G	50	6800 ±5%	5.0 x 3.5	3.15	5.0	K1	M1	M2
RPE5C1H822J2□□C03□	C0G	50	8200 ±5%	5.0 x 3.5	3.15	5.0	K1	M1	M2
RPE5C1H103J2□□C03□	C0G	50	10000 ±5%	5.0 x 3.5	3.15	5.0	K1	M1	M2
RPE5C1H123J4□□F03□	C0G	50	12000 ±5%	7.5 x 5.0	3.15	5.0	K1	M1	M2
RPE5C1H153J4□□F03□	C0G	50	15000 ±5%	7.5 x 5.0	3.15	5.0	K1	M1	M2
RPE5C1H183J5□□X03□	C0G	50	18000 ±5%	7.5 x 7.5	4.0	5.0	B1	E1	E2
RPE5C1H223J6□□F12□	C0G	50	22000 ±5%	10.0 x 10.0	4.0	5.0	B1	E1	E2
RPE5C1H273J6□□F12□	C0G	50	27000 ±5%	10.0 x 10.0	4.0	5.0	B1	E1	E2
RPE5C1H333J6□□F03□	C0G	50	33000 ±5%	10.0 x 10.0	4.0	5.0	B1	E1	E2
RPE5C1H393J6□□F03□	C0G	50	39000 ±5%	10.0 x 10.0	4.0	5.0	B1	E1	E2
RPE5C1H473J7□□F03□	C0G	50	47000 ±5%	12.5 x 12.5	5.0	10.0	C1	-	-
RPE5C1H563J7□□F03□	C0G	50	56000 ±5%	12.5 x 12.5	5.0	10.0	C1	-	-
RPE5C1H683J7□□F03□	C0G	50	68000 ±5%	12.5 x 12.5	5.0	10.0	C1	-	-
RPE5C2A1R0C2□□B03□	C0G	100	1.0 ±0.25pF	5.0 x 3.5	2.5	2.5	P1	S1	S2
RPE5C2A1R0C2□□B03□	C0G	100	1.0 ±0.25pF	5.0 x 3.5	2.5	5.0	K1	M1	M2
RPE5C2A2R0C2□□B03□	C0G	100	2.0 ±0.25pF	5.0 x 3.5	2.5	2.5	P1	S1	S2
RPE5C2A2R0C2□□B03□	C0G	100	2.0 ±0.25pF	5.0 x 3.5	2.5	5.0	K1	M1	M2
RPE5C2A3R0C2□□B03□	C0G	100	3.0 ±0.25pF	5.0 x 3.5	2.5	2.5	P1	S1	S2
RPE5C2A3R0C2□□B03□	C0G	100	3.0 ±0.25pF	5.0 x 3.5	2.5	5.0	K1	M1	M2
RPE5C2A4R0C2□□B03□	C0G	100	4.0 ±0.25pF	5.0 x 3.5	2.5	2.5	P1	S1	S2
RPE5C2A4R0C2□□B03□	C0G	100	4.0 ±0.25pF	5.0 x 3.5	2.5	5.0	K1	M1	M2
RPE5C2A5R0C2□□B03□	C0G	100	5.0 ±0.25pF	5.0 x 3.5	2.5	2.5	P1	S1	S2
RPE5C2A5R0C2□□B03□	C0G	100	5.0 ±0.25pF	5.0 x 3.5	2.5	5.0	K1	M1	M2
RPE5C2A6R0D2□□B03□	C0G	100	6.0 ±0.5pF	5.0 x 3.5	2.5	2.5	P1	S1	S2
RPE5C2A6R0D2□□B03□	C0G	100	6.0 ±0.5pF	5.0 x 3.5	2.5	5.0	K1	M1	M2
RPE5C2A7R0D2□□Z03□	C0G	100	7.0 ±0.5pF	5.0 x 3.5	2.5	2.5	P1	S1	S2
RPE5C2A7R0D2□□Z03□	C0G	100	7.0 ±0.5pF	5.0 x 3.5	2.5	5.0	K1	M1	M2
RPE5C2A8R0D2□□Z03□	C0G	100	8.0 ±0.5pF	5.0 x 3.5	2.5	2.5	P1	S1	S2
RPE5C2A8R0D2□□Z03□	C0G	100	8.0 ±0.5pF	5.0 x 3.5	2.5	5.0	K1	M1	M2
RPE5C2A9R0D2□□Z03□	C0G	100	9.0 ±0.5pF	5.0 x 3.5	2.5	2.5	P1	S1	S2
RPE5C2A9R0D2□□Z03□	C0G	100	9.0 ±0.5pF	5.0 x 3.5	2.5	5.0	K1	M1	M2
RPE5C2A100J2□□Z03□	C0G	100	10 ±5%	5.0 x 3.5	2.5	2.5	P1	S1	S2
RPE5C2A100J2□□Z03□	C0G	100	10 ±5%	5.0 x 3.5	2.5	5.0	K1	M1	M2
RPE5C2A120J2□□Z03□	C0G	100	12 ±5%	5.0 x 3.5	2.5	2.5	P1	S1	S2
RPE5C2A120J2□□Z03□	C0G	100	12 ±5%	5.0 x 3.5	2.5	5.0	K1	M1	M2
RPE5C2A150J2□□Z03□	C0G	100	15 ±5%	5.0 x 3.5	2.5	2.5	P1	S1	S2

Continued on the following page. ↗

△Note • This PDF catalog is downloaded from the website of Murata Manufacturing co., ltd. Therefore, it's specifications are subject to change or our products in it may be discontinued without advance notice. Please check with our sales representatives or product engineers before ordering.
 • This PDF catalog has only typical specifications because there is no space for detailed specifications. Therefore, please approve our product specifications or transact the approval sheet for product specifications before ordering.

Continued from the preceding page.

Part Number	TC	Rated Voltage (Vdc)	Capacitance (pF)	Dimensions LxW (mm)	Dimension T (mm)	Lead Space F (mm)	Lead Style Code Bulk	Lead Style Code Taping (1)	Lead Style Code Taping (2)
RPE5C2A150J2□□Z03□	C0G	100	15 ±5%	5.0 x 3.5	2.5	5.0	K1	M1	M2
RPE5C2A180J2□□Z03□	C0G	100	18 ±5%	5.0 x 3.5	2.5	2.5	P1	S1	S2
RPE5C2A180J2□□Z03□	C0G	100	18 ±5%	5.0 x 3.5	2.5	5.0	K1	M1	M2
RPE5C2A220J2□□Z03□	C0G	100	22 ±5%	5.0 x 3.5	2.5	2.5	P1	S1	S2
RPE5C2A220J2□□Z03□	C0G	100	22 ±5%	5.0 x 3.5	2.5	5.0	K1	M1	M2
RPE5C2A270J2□□Z03□	C0G	100	27 ±5%	5.0 x 3.5	2.5	2.5	P1	S1	S2
RPE5C2A270J2□□Z03□	C0G	100	27 ±5%	5.0 x 3.5	2.5	5.0	K1	M1	M2
RPE5C2A330J2□□Z03□	C0G	100	33 ±5%	5.0 x 3.5	2.5	2.5	P1	S1	S2
RPE5C2A330J2□□Z03□	C0G	100	33 ±5%	5.0 x 3.5	2.5	5.0	K1	M1	M2
RPE5C2A390J2□□Z03□	C0G	100	39 ±5%	5.0 x 3.5	2.5	2.5	P1	S1	S2
RPE5C2A390J2□□Z03□	C0G	100	39 ±5%	5.0 x 3.5	2.5	5.0	K1	M1	M2
RPE5C2A470J2□□Z03□	C0G	100	47 ±5%	5.0 x 3.5	2.5	2.5	P1	S1	S2
RPE5C2A470J2□□Z03□	C0G	100	47 ±5%	5.0 x 3.5	2.5	5.0	K1	M1	M2
RPE5C2A560J2□□Z03□	C0G	100	56 ±5%	5.0 x 3.5	2.5	2.5	P1	S1	S2
RPE5C2A560J2□□Z03□	C0G	100	56 ±5%	5.0 x 3.5	2.5	5.0	K1	M1	M2
RPE5C2A680J2□□Z03□	C0G	100	68 ±5%	5.0 x 3.5	2.5	2.5	P1	S1	S2
RPE5C2A680J2□□Z03□	C0G	100	68 ±5%	5.0 x 3.5	2.5	5.0	K1	M1	M2
RPE5C2A820J2□□Z03□	C0G	100	82 ±5%	5.0 x 3.5	2.5	2.5	P1	S1	S2
RPE5C2A820J2□□Z03□	C0G	100	82 ±5%	5.0 x 3.5	2.5	5.0	K1	M1	M2
RPE5C2A101J2□□A03□	C0G	100	100 ±5%	5.0 x 3.5	2.5	2.5	P1	S1	S2
RPE5C2A101J2□□A03□	C0G	100	100 ±5%	5.0 x 3.5	2.5	5.0	K1	M1	M2
RPE5C2A121J2□□A03□	C0G	100	120 ±5%	5.0 x 3.5	2.5	2.5	P1	S1	S2
RPE5C2A121J2□□A03□	C0G	100	120 ±5%	5.0 x 3.5	2.5	5.0	K1	M1	M2
RPE5C2A151J2□□A03□	C0G	100	150 ±5%	5.0 x 3.5	2.5	2.5	P1	S1	S2
RPE5C2A151J2□□A03□	C0G	100	150 ±5%	5.0 x 3.5	2.5	5.0	K1	M1	M2
RPE5C2A181J2□□A03□	C0G	100	180 ±5%	5.0 x 3.5	2.5	2.5	P1	S1	S2
RPE5C2A181J2□□A03□	C0G	100	180 ±5%	5.0 x 3.5	2.5	5.0	K1	M1	M2
RPE5C2A221J2□□A03□	C0G	100	220 ±5%	5.0 x 3.5	2.5	2.5	P1	S1	S2
RPE5C2A221J2□□A03□	C0G	100	220 ±5%	5.0 x 3.5	2.5	5.0	K1	M1	M2
RPE5C2A271J2□□A03□	C0G	100	270 ±5%	5.0 x 3.5	2.5	2.5	P1	S1	S2
RPE5C2A271J2□□A03□	C0G	100	270 ±5%	5.0 x 3.5	2.5	5.0	K1	M1	M2
RPE5C2A331J2□□A03□	C0G	100	330 ±5%	5.0 x 3.5	2.5	2.5	P1	S1	S2
RPE5C2A331J2□□A03□	C0G	100	330 ±5%	5.0 x 3.5	2.5	5.0	K1	M1	M2
RPE5C2A391J2□□A03□	C0G	100	390 ±5%	5.0 x 3.5	2.5	2.5	P1	S1	S2
RPE5C2A391J2□□A03□	C0G	100	390 ±5%	5.0 x 3.5	2.5	5.0	K1	M1	M2
RPE5C2A471J2□□A03□	C0G	100	470 ±5%	5.0 x 3.5	2.5	2.5	P1	S1	S2
RPE5C2A471J2□□A03□	C0G	100	470 ±5%	5.0 x 3.5	2.5	5.0	K1	M1	M2
RPE5C2A561J2□□A03□	C0G	100	560 ±5%	5.0 x 3.5	2.5	2.5	P1	S1	S2
RPE5C2A561J2□□A03□	C0G	100	560 ±5%	5.0 x 3.5	2.5	5.0	K1	M1	M2
RPE5C2A681J2□□A03□	C0G	100	680 ±5%	5.0 x 3.5	2.5	2.5	P1	S1	S2
RPE5C2A681J2□□A03□	C0G	100	680 ±5%	5.0 x 3.5	2.5	5.0	K1	M1	M2
RPE5C2A821J2□□A03□	C0G	100	820 ±5%	5.0 x 3.5	3.15	2.5	P1	S1	S2
RPE5C2A821J2□□A03□	C0G	100	820 ±5%	5.0 x 3.5	3.15	5.0	K1	M1	M2
RPE5C2A102J2□□A03□	C0G	100	1000 ±5%	5.0 x 3.5	3.15	2.5	P1	S1	S2
RPE5C2A102J2□□A03□	C0G	100	1000 ±5%	5.0 x 3.5	3.15	5.0	K1	M1	M2
RPE5C2A122J2□□A03□	C0G	100	1200 ±5%	5.0 x 3.5	3.15	2.5	P1	S1	S2
RPE5C2A122J2□□A03□	C0G	100	1200 ±5%	5.0 x 3.5	3.15	5.0	K1	M1	M2
RPE5C2A152J2□□A03□	C0G	100	1500 ±5%	5.0 x 3.5	3.15	2.5	P1	S1	S2
RPE5C2A152J2□□A03□	C0G	100	1500 ±5%	5.0 x 3.5	3.15	5.0	K1	M1	M2
RPE5C2A182J2□□D03□	C0G	100	1800 ±5%	5.0 x 3.5	3.15	2.5	P1	S1	S2
RPE5C2A182J2□□D03□	C0G	100	1800 ±5%	5.0 x 3.5	3.15	5.0	K1	M1	M2
RPE5C2A222J2□□D03□	C0G	100	2200 ±5%	5.0 x 3.5	3.15	2.5	P1	S1	S2
RPE5C2A222J2□□D03□	C0G	100	2200 ±5%	5.0 x 3.5	3.15	5.0	K1	M1	M2
RPE5C2A272J3□□D03□	C0G	100	2700 ±5%	5.0 x 4.5	3.15	2.5	P1	S1	S2
RPE5C2A272J3□□D03□	C0G	100	2700 ±5%	5.0 x 4.5	3.15	5.0	K1	M1	M2

Continued on the following page.

Note • This PDF catalog is downloaded from the website of Murata Manufacturing co., Ltd. Therefore, it's specifications are subject to change or our products in it may be discontinued without advance notice. Please check with our sales representatives or product engineers before ordering.
 • This PDF catalog has only typical specifications because there is no space for detailed specifications. Therefore, please approve our product specifications or transact the approval sheet for product specifications before ordering.

Continued from the preceding page.

Part Number	TC	Rated Voltage (Vdc)	Capacitance (pF)	Dimensions LxW (mm)	Dimension T (mm)	Lead Space F (mm)	Lead Style Code Bulk	Lead Style Code Taping (1)	Lead Style Code Taping (2)
RPE5C2A332J3□□D03□	C0G	100	3300 ±5%	5.0 x 4.5	3.15	2.5	P1	S1	S2
RPE5C2A332J3□□D03□	C0G	100	3300 ±5%	5.0 x 4.5	3.15	5.0	K1	M1	M2
RPE5C2A392J3□□D03□	C0G	100	3900 ±5%	5.0 x 4.5	3.15	2.5	P1	S1	S2
RPE5C2A392J3□□D03□	C0G	100	3900 ±5%	5.0 x 4.5	3.15	5.0	K1	M1	M2
RPE5C2A472J4□□X03□	C0G	100	4700 ±5%	7.5 x 5.0	2.5	5.0	K1	M1	M2
RPE5C2A562J4□□F03□	C0G	100	5600 ±5%	7.5 x 5.0	3.15	5.0	K1	M1	M2
RPE5C2A682J4□□F03□	C0G	100	6800 ±5%	7.5 x 5.0	3.15	5.0	K1	M1	M2
RPE5C2A822J5□□X03□	C0G	100	8200 ±5%	7.5 x 7.5	4.0	5.0	B1	E1	E2
RPE5C2A103J5□□X03□	C0G	100	10000 ±5%	7.5 x 7.5	4.0	5.0	B1	E1	E2
RPE5C2A123J5□□X03□	C0G	100	12000 ±5%	7.5 x 7.5	4.0	5.0	B1	E1	E2
RPE5C2A153J6□□X13□	C0G	100	15000 ±5%	10.0 x 10.0	4.0	5.0	B1	E1	E2
RPE5C2A183J6□□X13□	C0G	100	18000 ±5%	10.0 x 10.0	4.0	5.0	B1	E1	E2
RPE5C2A223J6□□X03□	C0G	100	22000 ±5%	10.0 x 10.0	4.0	5.0	B1	E1	E2
RPE5C2A273J6□□X03□	C0G	100	27000 ±5%	10.0 x 10.0	4.0	5.0	B1	E1	E2
RPE5C2A333J6□□F03□	C0G	100	33000 ±5%	10.0 x 10.0	4.0	5.0	B1	E1	E2
RPE5C2A393J7□□X03□	C0G	100	39000 ±5%	12.5 x 12.5	5.0	10.0	C1	-	-
RPE5C2A473J7□□F03□	C0G	100	47000 ±5%	12.5 x 12.5	5.0	10.0	C1	-	-
RPE5C2A563J7□□F03□	C0G	100	56000 ±5%	12.5 x 12.5	5.0	10.0	C1	-	-

Two blank columns are filled with the lead style code. Please refer to the 3 columns on the right for the appropriate code.
 The last blank column is filled with the packaging code. (B: bulk, A: ammo pack)
 Operating Temperature Range: -55 to +125deg.

● High Dielectric Constant Type, X7R Characteristics

Part Number	TC	Rated Voltage (Vdc)	Capacitance	Dimensions LxW (mm)	Dimension T (mm)	Lead Space F (mm)	Lead Style Code Bulk	Lead Style Code Taping (1)	Lead Style Code Taping (2)
RPER71E474K2□□A03□	X7R	25	0.47µF ±10%	5.0 x 3.5	3.15	5.0	K1	M1	M2
RPER71E684K2□□C03□	X7R	25	0.68µF ±10%	5.0 x 3.5	3.15	5.0	K1	M1	M2
RPER71E105K2□□C03□	X7R	25	1.0µF ±10%	5.0 x 3.5	3.15	5.0	K1	M1	M2
RPER71E155K3□□C07□	X7R	25	1.5µF ±10%	5.0 x 4.5	3.15	5.0	K1	M1	M2
RPER71E225K3□□C07□	X7R	25	2.2µF ±10%	5.0 x 4.5	3.15	5.0	K1	M1	M2
RPER71H221K2□□A03□	X7R	50	220pF ±10%	5.0 x 3.5	2.5	2.5	P1	S1	S2
RPER71H221K2□□A03□	X7R	50	220pF ±10%	5.0 x 3.5	2.5	5.0	K1	M1	M2
RPER71H331K2□□A03□	X7R	50	330pF ±10%	5.0 x 3.5	2.5	2.5	P1	S1	S2
RPER71H331K2□□A03□	X7R	50	330pF ±10%	5.0 x 3.5	2.5	5.0	K1	M1	M2
RPER71H471K2□□A03□	X7R	50	470pF ±10%	5.0 x 3.5	2.5	2.5	P1	S1	S2
RPER71H471K2□□A03□	X7R	50	470pF ±10%	5.0 x 3.5	2.5	5.0	K1	M1	M2
RPER71H681K2□□A03□	X7R	50	680pF ±10%	5.0 x 3.5	2.5	2.5	P1	S1	S2
RPER71H681K2□□A03□	X7R	50	680pF ±10%	5.0 x 3.5	2.5	5.0	K1	M1	M2
RPER71H102K2□□A03□	X7R	50	1000pF ±10%	5.0 x 3.5	2.5	2.5	P1	S1	S2
RPER71H102K2□□A03□	X7R	50	1000pF ±10%	5.0 x 3.5	2.5	5.0	K1	M1	M2
RPER71H152K2□□A03□	X7R	50	1500pF ±10%	5.0 x 3.5	2.5	2.5	P1	S1	S2
RPER71H152K2□□A03□	X7R	50	1500pF ±10%	5.0 x 3.5	2.5	5.0	K1	M1	M2
RPER71H222K2□□A03□	X7R	50	2200pF ±10%	5.0 x 3.5	2.5	2.5	P1	S1	S2
RPER71H222K2□□A03□	X7R	50	2200pF ±10%	5.0 x 3.5	2.5	5.0	K1	M1	M2
RPER71H332K2□□A03□	X7R	50	3300pF ±10%	5.0 x 3.5	2.5	2.5	P1	S1	S2
RPER71H332K2□□A03□	X7R	50	3300pF ±10%	5.0 x 3.5	2.5	5.0	K1	M1	M2
RPER71H472K2□□A03□	X7R	50	4700pF ±10%	5.0 x 3.5	2.5	2.5	P1	S1	S2
RPER71H472K2□□A03□	X7R	50	4700pF ±10%	5.0 x 3.5	2.5	5.0	K1	M1	M2
RPER71H682K2□□A03□	X7R	50	6800pF ±10%	5.0 x 3.5	2.5	2.5	P1	S1	S2
RPER71H682K2□□A03□	X7R	50	6800pF ±10%	5.0 x 3.5	2.5	5.0	K1	M1	M2
RPER71H103K2□□A03□	X7R	50	10000pF ±10%	5.0 x 3.5	2.5	2.5	P1	S1	S2
RPER71H103K2□□A03□	X7R	50	10000pF ±10%	5.0 x 3.5	2.5	5.0	K1	M1	M2
RPER71H153K2□□A03□	X7R	50	15000pF ±10%	5.0 x 3.5	2.5	2.5	P1	S1	S2

Continued on the following page. ↗

△Note • This PDF catalog is downloaded from the website of Murata Manufacturing co., ltd. Therefore, it's specifications are subject to change or our products in it may be discontinued without advance notice. Please check with our sales representatives or product engineers before ordering.
 • This PDF catalog has only typical specifications because there is no space for detailed specifications. Therefore, please approve our product specifications or transact the approval sheet for product specifications before ordering.

Continued from the preceding page.

Part Number	TC	Rated Voltage (Vdc)	Capacitance	Dimensions LxW (mm)	Dimension T (mm)	Lead Space F (mm)	Lead Style Code Bulk	Lead Style Code Taping (1)	Lead Style Code Taping (2)
RPER71H153K2□□A03□	X7R	50	15000pF ±10%	5.0 x 3.5	2.5	5.0	K1	M1	M2
RPER71H223K2□□A03□	X7R	50	22000pF ±10%	5.0 x 3.5	2.5	2.5	P1	S1	S2
RPER71H223K2□□A03□	X7R	50	22000pF ±10%	5.0 x 3.5	2.5	5.0	K1	M1	M2
RPER71H333K2□□A03□	X7R	50	33000pF ±10%	5.0 x 3.5	3.15	2.5	P1	S1	S2
RPER71H333K2□□A03□	X7R	50	33000pF ±10%	5.0 x 3.5	3.15	5.0	K1	M1	M2
RPER71H473K2□□A03□	X7R	50	47000pF ±10%	5.0 x 3.5	3.15	2.5	P1	S1	S2
RPER71H473K2□□A03□	X7R	50	47000pF ±10%	5.0 x 3.5	3.15	5.0	K1	M1	M2
RPER71H683K2□□A03□	X7R	50	68000pF ±10%	5.0 x 3.5	3.15	2.5	P1	S1	S2
RPER71H683K2□□A03□	X7R	50	68000pF ±10%	5.0 x 3.5	3.15	5.0	K1	M1	M2
RPER71H104K2□□A03□	X7R	50	0.10μF ±10%	5.0 x 3.5	3.15	2.5	P1	S1	S2
RPER71H104K2□□A03□	X7R	50	0.10μF ±10%	5.0 x 3.5	3.15	5.0	K1	M1	M2
RPER71H154K2□□C03□	X7R	50	0.15μF ±10%	5.0 x 3.5	3.15	2.5	P1	S1	S2
RPER71H154K2□□C03□	X7R	50	0.15μF ±10%	5.0 x 3.5	3.15	5.0	K1	M1	M2
RPER71H224K2□□C03□	X7R	50	0.22μF ±10%	5.0 x 3.5	3.15	2.5	P1	S1	S2
RPER71H224K2□□C03□	X7R	50	0.22μF ±10%	5.0 x 3.5	3.15	5.0	K1	M1	M2
RPER71H334K2□□C03□	X7R	50	0.33μF ±10%	5.0 x 3.5	2.5	2.5	P1	S1	S2
RPER71H334K2□□C03□	X7R	50	0.33μF ±10%	5.0 x 3.5	2.5	5.0	K1	M1	M2
RPER71H474K2□□C03□	X7R	50	0.47μF ±10%	5.0 x 3.5	3.15	2.5	P1	S1	S2
RPER71H474K2□□C03□	X7R	50	0.47μF ±10%	5.0 x 3.5	3.15	5.0	K1	M1	M2
RPER71H684K3□□C03□	X7R	50	0.68μF ±10%	5.0 x 4.5	3.15	2.5	P1	S1	S2
RPER71H684K3□□C03□	X7R	50	0.68μF ±10%	5.0 x 4.5	3.15	5.0	K1	M1	M2
RPER71H105K3□□C07□	X7R	50	1.0μF ±10%	5.0 x 4.5	3.15	2.5	P1	S1	S2
RPER71H105K3□□C07□	X7R	50	1.0μF ±10%	5.0 x 4.5	3.15	5.0	K1	M1	M2
RPER71H155K8□□C03□	X7R	50	1.5μF ±10%	7.5 x 5.5	4.0	5.0	K1	M1	M2
RPER71H225K8□□C03□	X7R	50	2.2μF ±10%	7.5 x 5.5	4.0	5.0	K1	M1	M2
RPER71H335K5□□C03□	X7R	50	3.3μF ±10%	7.5 x 7.5	5.0	5.0	B1	E1	E2
RPER71H475K5□□C03□	X7R	50	4.7μF ±10%	7.5 x 7.5	4.0	5.0	B1	E1	E2
RPER72A221K2□□B03□	X7R	100	220pF ±10%	5.0 x 3.5	2.5	2.5	P1	S1	S2
RPER72A221K2□□B03□	X7R	100	220pF ±10%	5.0 x 3.5	2.5	5.0	K1	M1	M2
RPER72A331K2□□B03□	X7R	100	330pF ±10%	5.0 x 3.5	2.5	2.5	P1	S1	S2
RPER72A331K2□□B03□	X7R	100	330pF ±10%	5.0 x 3.5	2.5	5.0	K1	M1	M2
RPER72A471K2□□B03□	X7R	100	470pF ±10%	5.0 x 3.5	2.5	2.5	P1	S1	S2
RPER72A471K2□□B03□	X7R	100	470pF ±10%	5.0 x 3.5	2.5	5.0	K1	M1	M2
RPER72A681K2□□B03□	X7R	100	680pF ±10%	5.0 x 3.5	2.5	2.5	P1	S1	S2
RPER72A681K2□□B03□	X7R	100	680pF ±10%	5.0 x 3.5	2.5	5.0	K1	M1	M2
RPER72A102K2□□A03□	X7R	100	1000pF ±10%	5.0 x 3.5	2.5	2.5	P1	S1	S2
RPER72A102K2□□A03□	X7R	100	1000pF ±10%	5.0 x 3.5	2.5	5.0	K1	M1	M2
RPER72A152K2□□A03□	X7R	100	1500pF ±10%	5.0 x 3.5	2.5	2.5	P1	S1	S2
RPER72A152K2□□A03□	X7R	100	1500pF ±10%	5.0 x 3.5	2.5	5.0	K1	M1	M2
RPER72A222K2□□A03□	X7R	100	2200pF ±10%	5.0 x 3.5	2.5	2.5	P1	S1	S2
RPER72A222K2□□A03□	X7R	100	2200pF ±10%	5.0 x 3.5	2.5	5.0	K1	M1	M2
RPER72A332K2□□A03□	X7R	100	3300pF ±10%	5.0 x 3.5	2.5	2.5	P1	S1	S2
RPER72A332K2□□A03□	X7R	100	3300pF ±10%	5.0 x 3.5	2.5	5.0	K1	M1	M2
RPER72A472K2□□A03□	X7R	100	4700pF ±10%	5.0 x 3.5	2.5	2.5	P1	S1	S2
RPER72A472K2□□A03□	X7R	100	4700pF ±10%	5.0 x 3.5	2.5	5.0	K1	M1	M2
RPER72A682K2□□A03□	X7R	100	6800pF ±10%	5.0 x 3.5	2.5	2.5	P1	S1	S2
RPER72A682K2□□A03□	X7R	100	6800pF ±10%	5.0 x 3.5	2.5	5.0	K1	M1	M2
RPER72A103K2□□A03□	X7R	100	10000pF ±10%	5.0 x 3.5	3.15	2.5	P1	S1	S2
RPER72A103K2□□A03□	X7R	100	10000pF ±10%	5.0 x 3.5	3.15	5.0	K1	M1	M2
RPER72A153K2□□A03□	X7R	100	15000pF ±10%	5.0 x 3.5	3.15	2.5	P1	S1	S2
RPER72A153K2□□A03□	X7R	100	15000pF ±10%	5.0 x 3.5	3.15	5.0	K1	M1	M2
RPER72A223K2□□A03□	X7R	100	22000pF ±10%	5.0 x 3.5	3.15	2.5	P1	S1	S2
RPER72A223K2□□A03□	X7R	100	22000pF ±10%	5.0 x 3.5	3.15	5.0	K1	M1	M2
RPER72A333K2□□C03□	X7R	100	33000pF ±10%	5.0 x 3.5	3.15	2.5	P1	S1	S2
RPER72A333K2□□C03□	X7R	100	33000pF ±10%	5.0 x 3.5	3.15	5.0	K1	M1	M2

Continued on the following page.

Note • This PDF catalog is downloaded from the website of Murata Manufacturing co., Ltd. Therefore, it's specifications are subject to change or our products in it may be discontinued without advance notice. Please check with our sales representatives or product engineers before ordering.
 • This PDF catalog has only typical specifications because there is no space for detailed specifications. Therefore, please approve our product specifications or transact the approval sheet for product specifications before ordering.

Continued from the preceding page.

Part Number	TC	Rated Voltage (Vdc)	Capacitance	Dimensions LxW (mm)	Dimension T (mm)	Lead Space F (mm)	Lead Style Code Bulk	Lead Style Code Taping (1)	Lead Style Code Taping (2)
RPER72A473K2□□C03□	X7R	100	47000pF ±10%	5.0 x 3.5	3.15	2.5	P1	S1	S2
RPER72A473K2□□C03□	X7R	100	47000pF ±10%	5.0 x 3.5	3.15	5.0	K1	M1	M2
RPER72A683K3□□C07□	X7R	100	68000pF ±10%	5.0 x 4.5	3.15	2.5	P1	S1	S2
RPER72A683K3□□C07□	X7R	100	68000pF ±10%	5.0 x 4.5	3.15	5.0	K1	M1	M2
RPER72A104K3□□C07□	X7R	100	0.10µF ±10%	5.0 x 4.5	3.15	2.5	P1	S1	S2
RPER72A104K3□□C07□	X7R	100	0.10µF ±10%	5.0 x 4.5	3.15	5.0	K1	M1	M2
RPER72A154K8□□C03□	X7R	100	0.15µF ±10%	7.5 x 5.5	4.0	5.0	K1	M1	M2
RPER72A224K8□□C03□	X7R	100	0.22µF ±10%	7.5 x 5.5	4.0	5.0	K1	M1	M2
RPER72A334K5□□C03□	X7R	100	0.33µF ±10%	7.5 x 7.5	4.0	5.0	B1	E1	E2
RPER72A474K8□□C03□	X7R	100	0.47µF ±10%	7.5 x 5.5	4.0	5.0	K1	M1	M2
RPER72A684K6□□F14□	X7R	100	0.68µF ±10%	10.0 x 10.0	4.0	5.0	B1	E1	E2
RPER72A105K5□□C03□	X7R	100	1.0µF ±10%	7.5 x 7.5	4.0	5.0	B1	E1	E2
RPER72A155K7□□F03□	X7R	100	1.5µF ±10%	12.5 x 12.5	5.0	10.0	C1	-	-
RPER72A225K7□□F03□	X7R	100	2.2µF ±10%	12.5 x 12.5	5.0	10.0	C1	-	-

Two blank columns are filled with the lead style code. Please refer to the 3 columns on the right for the appropriate code.
 The last blank column is filled with the packaging code. (B: bulk, A: ammo pack)
 Operating Temperature Range: -55 to +125deg.

● High Dielectric Constant Type, Y5V Characteristics

Part Number	TC	Rated Voltage (Vdc)	Capacitance	Dimensions LxW (mm)	Dimension T (mm)	Lead Space F (mm)	Lead Style Code Bulk	Lead Style Code Taping (1)	Lead Style Code Taping (2)
RPEF51E105Z3□□C03□	Y5V	25	1.0µF +80/-20%	5.0 x 4.5	2.5	2.5	P1	S1	S2
RPEF51E105Z3□□C03□	Y5V	25	1.0µF +80/-20%	5.0 x 4.5	2.5	5.0	K1	M1	M2
RPEF51H102Z2□□A03□	Y5V	50	1000pF +80/-20%	5.0 x 3.5	2.5	2.5	P1	S1	S2
RPEF51H102Z2□□A03□	Y5V	50	1000pF +80/-20%	5.0 x 3.5	2.5	5.0	K1	M1	M2
RPEF51H222Z2□□A03□	Y5V	50	2200pF +80/-20%	5.0 x 3.5	2.5	2.5	P1	S1	S2
RPEF51H222Z2□□A03□	Y5V	50	2200pF +80/-20%	5.0 x 3.5	2.5	5.0	K1	M1	M2
RPEF51H472Z2□□A03□	Y5V	50	4700pF +80/-20%	5.0 x 3.5	2.5	2.5	P1	S1	S2
RPEF51H472Z2□□A03□	Y5V	50	4700pF +80/-20%	5.0 x 3.5	2.5	5.0	K1	M1	M2
RPEF51H103Z2□□A03□	Y5V	50	10000pF +80/-20%	5.0 x 3.5	2.5	2.5	P1	S1	S2
RPEF51H103Z2□□A03□	Y5V	50	10000pF +80/-20%	5.0 x 3.5	2.5	5.0	K1	M1	M2
RPEF51H223Z2□□A03□	Y5V	50	22000pF +80/-20%	5.0 x 3.5	2.5	2.5	P1	S1	S2
RPEF51H223Z2□□A03□	Y5V	50	22000pF +80/-20%	5.0 x 3.5	2.5	5.0	K1	M1	M2
RPEF51H473Z2□□A03□	Y5V	50	47000pF +80/-20%	5.0 x 3.5	2.5	2.5	P1	S1	S2
RPEF51H473Z2□□A03□	Y5V	50	47000pF +80/-20%	5.0 x 3.5	2.5	5.0	K1	M1	M2
RPEF51H104Z2□□A03□	Y5V	50	0.10µF +80/-20%	5.0 x 3.5	2.5	2.5	P1	S1	S2
RPEF51H104Z2□□A03□	Y5V	50	0.10µF +80/-20%	5.0 x 3.5	2.5	5.0	K1	M1	M2
RPEF51H224Z2□□A03□	Y5V	50	0.22µF +80/-20%	5.0 x 3.5	3.15	2.5	P1	S1	S2
RPEF51H224Z2□□A03□	Y5V	50	0.22µF +80/-20%	5.0 x 3.5	3.15	5.0	K1	M1	M2
RPEF51H474Z2□□C03□	Y5V	50	0.47µF +80/-20%	5.0 x 3.5	3.15	2.5	P1	S1	S2
RPEF51H474Z2□□C03□	Y5V	50	0.47µF +80/-20%	5.0 x 3.5	3.15	5.0	K1	M1	M2

Two blank columns are filled with the lead style code. Please refer to the 3 columns on the right for the appropriate code.
 The last blank column is filled with the packaging code. (B: bulk, A: ammo pack)
 Operating Temperature Range: -30 to +85deg.

△Note • This PDF catalog is downloaded from the website of Murata Manufacturing co., ltd. Therefore, it's specifications are subject to change or our products in it may be discontinued without advance notice. Please check with our sales representatives or product engineers before ordering.
 • This PDF catalog has only typical specifications because there is no space for detailed specifications. Therefore, please approve our product specifications or transact the approval sheet for product specifications before ordering.

Monolithic Ceramic Capacitors (Lead Type)

RPE Series Small Size, Large Capacitance(DC50V)

●Part number configuration (Please see page 22 for details)

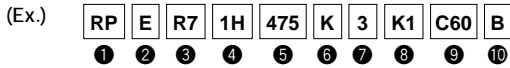

●Dimensions

Dimensions and Lead Style Code	Dimensions (mm)					
	L	W	W1	T	F	d
2K1/2M1	5.5	4.0	6.0	Depends on Part Number List	5.0	0.5
3K1/3M1	5.5	5.0	7.5		5.0	0.5

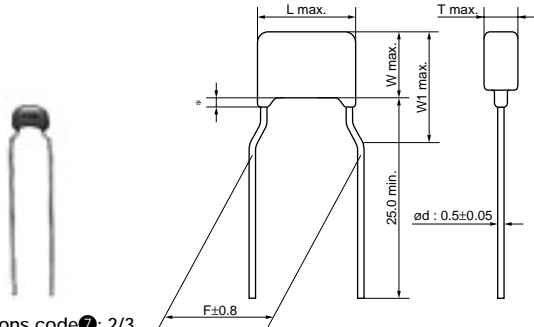

Dimensions code 7: 2/3
Lead style code 8: K1

* Coating extension does not exceed the end of the lead bend.
· Lead Wire : Solder Coated Copper Wire or Solder Coated CP Wire (in mm)

Part Number	TC	Rated Voltage (Vdc)	Capacitance (μF)	Dimensions LxW (mm)	Dimension T (mm)	Lead Space F (mm)	Lead Style Code Bulk	Lead Style Code Taping (1)	Lead Style Code Taping (2)
RPER71H105K2□□C60□	X7R	50	1.0 ±10%	5.5 x 4.0	3.15	5.0	K1	M1	-
RPER71H155K2□□C60□	X7R	50	1.5 ±10%	5.5 x 4.0	3.15	5.0	K1	M1	-
RPER71H225K2□□C60□	X7R	50	2.2 ±10%	5.5 x 4.0	3.15	5.0	K1	M1	-
RPER71H335K3□□C60□	X7R	50	3.3 ±10%	5.5 x 5.0	4.0	5.0	K1	M1	-
RPER71H475K3□□C60□	X7R	50	4.7 ±10%	5.5 x 5.0	4.0	5.0	K1	M1	-

Two blank columns are filled with the lead style code. Please refer to the 3 columns on the right for the appropriate code.
The last blank column is filled with the packaging code. (B: bulk, A: ammo pack)
Operating Temperature Range: -55 to +125deg.

Monolithic Ceramic Capacitors (Lead Type)

RH Series 150deg.C max.(for Automotive) (DC50V-DC100V)

●Part number configuration (Please see page 22 for details)

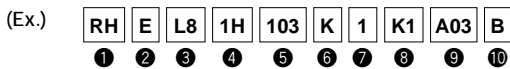

●Dimensions

Dimensions and Lead Style Code	Dimensions (mm)					
	L	W	W1	T	F	d
1A2/1DB	4.0	3.5	-	See the individual product specifications	2.5	0.5
1K1/1M1	4.0	3.5	5.0		5.0	0.5
2A2/2DB	5.7	4.5	-		2.5	0.5
2K1/2M1	5.7	4.5	7.0		5.0	0.5

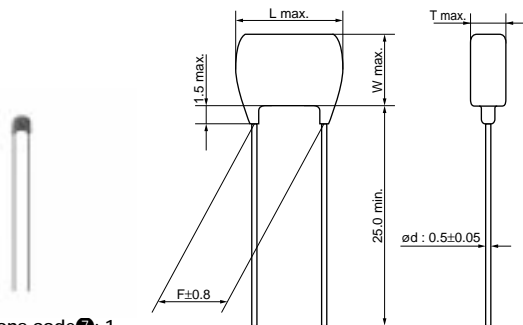

Dimensions code 7: 1
Lead style code 8: A2

· Lead Wire : Solder Coated Copper Wire or Solder Coated CP Wire (in mm)

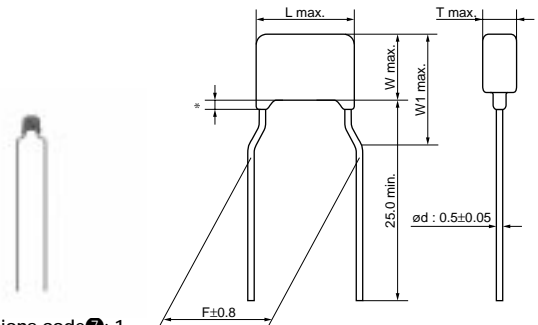

Dimensions code 7: 1
Lead style code 8: K1

* Coating extension does not exceed the end of the lead bend.
· Lead Wire : Solder Coated Copper Wire or Solder Coated CP Wire (in mm)

Continued on the following page. ↗

Continued from the preceding page.

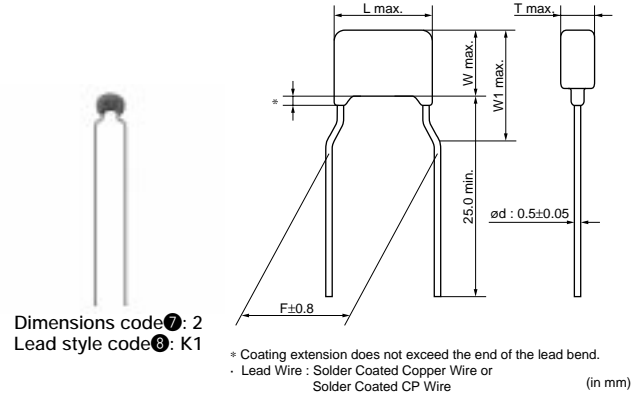
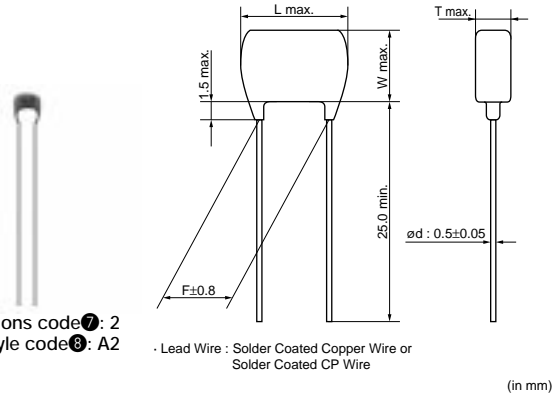

Part Number	TC	Rated Voltage (Vdc)	Capacitance	Dimensions LxW (mm)	Dimension T (mm)	Lead Space F (mm)	Lead Style Code Bulk	Lead Style Code Taping (1)	Lead Style Code Taping (2)
RHEL81H102K1□□A03□	X8L	50	1000pF ±10%	4.0 x 3.5	2.5	2.5	A2	DB	-
RHEL81H102K1□□A03□	X8L	50	1000pF ±10%	4.0 x 3.5	2.5	5.0	K1	M1	-
RHEL81H152K1□□A03□	X8L	50	1500pF ±10%	4.0 x 3.5	2.5	2.5	A2	DB	-
RHEL81H152K1□□A03□	X8L	50	1500pF ±10%	4.0 x 3.5	2.5	5.0	K1	M1	-
RHEL81H222K1□□A03□	X8L	50	2200pF ±10%	4.0 x 3.5	2.5	2.5	A2	DB	-
RHEL81H222K1□□A03□	X8L	50	2200pF ±10%	4.0 x 3.5	2.5	5.0	K1	M1	-
RHEL81H332K1□□A03□	X8L	50	3300pF ±10%	4.0 x 3.5	2.5	2.5	A2	DB	-
RHEL81H332K1□□A03□	X8L	50	3300pF ±10%	4.0 x 3.5	2.5	5.0	K1	M1	-
RHEL81H472K1□□A03□	X8L	50	4700pF ±10%	4.0 x 3.5	2.5	2.5	A2	DB	-
RHEL81H472K1□□A03□	X8L	50	4700pF ±10%	4.0 x 3.5	2.5	5.0	K1	M1	-
RHEL81H682K1□□A03□	X8L	50	6800pF ±10%	4.0 x 3.5	2.5	2.5	A2	DB	-
RHEL81H682K1□□A03□	X8L	50	6800pF ±10%	4.0 x 3.5	2.5	5.0	K1	M1	-
RHEL81H103K1□□A03□	X8L	50	10000pF ±10%	4.0 x 3.5	2.5	2.5	A2	DB	-
RHEL81H103K1□□A03□	X8L	50	10000pF ±10%	4.0 x 3.5	2.5	5.0	K1	M1	-
RHEL81H153K1□□A03□	X8L	50	15000pF ±10%	4.0 x 3.5	2.5	2.5	A2	DB	-
RHEL81H153K1□□A03□	X8L	50	15000pF ±10%	4.0 x 3.5	2.5	5.0	K1	M1	-
RHEL81H223K1□□A03□	X8L	50	22000pF ±10%	4.0 x 3.5	2.5	2.5	A2	DB	-
RHEL81H223K1□□A03□	X8L	50	22000pF ±10%	4.0 x 3.5	2.5	5.0	K1	M1	-
RHEL81H333K1□□A03□	X8L	50	33000pF ±10%	4.0 x 3.5	3.15	2.5	A2	DB	-
RHEL81H333K1□□A03□	X8L	50	33000pF ±10%	4.0 x 3.5	3.15	5.0	K1	M1	-
RHEL81H473K1□□A03□	X8L	50	47000pF ±10%	4.0 x 3.5	3.15	2.5	A2	DB	-
RHEL81H473K1□□A03□	X8L	50	47000pF ±10%	4.0 x 3.5	3.15	5.0	K1	M1	-
RHEL81H683K1□□A03□	X8L	50	68000pF ±10%	4.0 x 3.5	3.15	2.5	A2	DB	-
RHEL81H683K1□□A03□	X8L	50	68000pF ±10%	4.0 x 3.5	3.15	5.0	K1	M1	-
RHEL81H104K1□□A03□	X8L	50	0.10µF ±10%	4.0 x 3.5	3.15	2.5	A2	DB	-
RHEL81H104K1□□A03□	X8L	50	0.10µF ±10%	4.0 x 3.5	3.15	5.0	K1	M1	-
RHDL81H154K2□□C03□	X8L	50	0.15µF ±10%	5.7 x 4.5	4.5	2.5	A2	DB	-
RHDL81H154K2□□C03□	X8L	50	0.15µF ±10%	5.7 x 4.5	4.5	5.0	K1	M1	-
RHDL81H224K2□□C03□	X8L	50	0.22µF ±10%	5.7 x 4.5	4.5	2.5	A2	DB	-
RHDL81H224K2□□C03□	X8L	50	0.22µF ±10%	5.7 x 4.5	4.5	5.0	K1	M1	-
RHDL81H334K2□□C03□	X8L	50	0.33µF ±10%	5.7 x 4.5	4.5	2.5	A2	DB	-
RHDL81H334K2□□C03□	X8L	50	0.33µF ±10%	5.7 x 4.5	4.5	5.0	K1	M1	-
RHDL81H474K2□□C03□	X8L	50	0.47µF ±10%	5.7 x 4.5	4.5	2.5	A2	DB	-
RHDL81H474K2□□C03□	X8L	50	0.47µF ±10%	5.7 x 4.5	4.5	5.0	K1	M1	-
RHDL81H684K2□□C03□	X8L	50	0.68µF ±10%	5.7 x 4.5	4.5	2.5	A2	DB	-
RHDL81H684K2□□C03□	X8L	50	0.68µF ±10%	5.7 x 4.5	4.5	5.0	K1	M1	-
RHDL81H105K2□□C03□	X8L	50	1.0µF ±10%	5.7 x 4.5	4.5	2.5	A2	DB	-
RHDL81H105K2□□C03□	X8L	50	1.0µF ±10%	5.7 x 4.5	4.5	5.0	K1	M1	-
RHEL82A102K1□□A03□	X8L	100	1000pF ±10%	4.0 x 3.5	2.5	2.5	A2	DB	-
RHEL82A102K1□□A03□	X8L	100	1000pF ±10%	4.0 x 3.5	2.5	5.0	K1	M1	-
RHEL82A152K1□□A03□	X8L	100	1500pF ±10%	4.0 x 3.5	2.5	2.5	A2	DB	-

Continued on the following page. ↗

△Note • This PDF catalog is downloaded from the website of Murata Manufacturing co., ltd. Therefore, it's specifications are subject to change or our products in it may be discontinued without advance notice. Please check with our sales representatives or product engineers before ordering.
• This PDF catalog has only typical specifications because there is no space for detailed specifications. Therefore, please approve our product specifications or transact the approval sheet for product specifications before ordering.

Continued from the preceding page.

Part Number	TC	Rated Voltage (Vdc)	Capacitance	Dimensions LxW (mm)	Dimension T (mm)	Lead Space F (mm)	Lead Style Code Bulk	Lead Style Code Taping (1)	Lead Style Code Taping (2)
RHEL82A152K1□□A03□	X8L	100	1500pF ±10%	4.0 x 3.5	2.5	5.0	K1	M1	-
RHEL82A222K1□□A03□	X8L	100	2200pF ±10%	4.0 x 3.5	2.5	2.5	A2	DB	-
RHEL82A222K1□□A03□	X8L	100	2200pF ±10%	4.0 x 3.5	2.5	5.0	K1	M1	-
RHEL82A332K1□□A03□	X8L	100	3300pF ±10%	4.0 x 3.5	2.5	2.5	A2	DB	-
RHEL82A332K1□□A03□	X8L	100	3300pF ±10%	4.0 x 3.5	2.5	5.0	K1	M1	-
RHEL82A472K1□□A03□	X8L	100	4700pF ±10%	4.0 x 3.5	2.5	2.5	A2	DB	-
RHEL82A472K1□□A03□	X8L	100	4700pF ±10%	4.0 x 3.5	2.5	5.0	K1	M1	-
RHEL82A682K1□□A03□	X8L	100	6800pF ±10%	4.0 x 3.5	2.5	2.5	A2	DB	-
RHEL82A682K1□□A03□	X8L	100	6800pF ±10%	4.0 x 3.5	2.5	5.0	K1	M1	-
RHEL82A103K1□□A03□	X8L	100	10000pF ±10%	4.0 x 3.5	3.15	2.5	A2	DB	-
RHEL82A103K1□□A03□	X8L	100	10000pF ±10%	4.0 x 3.5	3.15	5.0	K1	M1	-
RHEL82A153K1□□A03□	X8L	100	15000pF ±10%	4.0 x 3.5	3.15	2.5	A2	DB	-
RHEL82A153K1□□A03□	X8L	100	15000pF ±10%	4.0 x 3.5	3.15	5.0	K1	M1	-
RHEL82A223K1□□A03□	X8L	100	22000pF ±10%	4.0 x 3.5	3.15	2.5	A2	DB	-
RHEL82A223K1□□A03□	X8L	100	22000pF ±10%	4.0 x 3.5	3.15	5.0	K1	M1	-
RHDL82A333K2□□C03□	X8L	100	33000pF ±10%	5.7 x 4.5	4.5	2.5	A2	DB	-
RHDL82A333K2□□C03□	X8L	100	33000pF ±10%	5.7 x 4.5	4.5	5.0	K1	M1	-
RHDL82A473K2□□C03□	X8L	100	47000pF ±10%	5.7 x 4.5	4.5	2.5	A2	DB	-
RHDL82A473K2□□C03□	X8L	100	47000pF ±10%	5.7 x 4.5	4.5	5.0	K1	M1	-
RHDL82A683K2□□C03□	X8L	100	68000pF ±10%	5.7 x 4.5	4.5	2.5	A2	DB	-
RHDL82A683K2□□C03□	X8L	100	68000pF ±10%	5.7 x 4.5	4.5	5.0	K1	M1	-
RHDL82A104K2□□C03□	X8L	100	0.10μF ±10%	5.7 x 4.5	4.5	2.5	A2	DB	-
RHDL82A104K2□□C03□	X8L	100	0.10μF ±10%	5.7 x 4.5	4.5	5.0	K1	M1	-

Two blank columns are filled with the lead style code. Please refer to the 3 columns on the right for the appropriate code.
The last blank column is filled with the packaging code. (B: bulk, A: ammo pack)
Operating Temperature Range: -55 to +150deg.

Monolithic Ceramic Capacitors (Lead Type)

RDE Series (Only for Commercial Use) (DC250V-DC630V)

●Part number configuration (Please see page 22 for details)

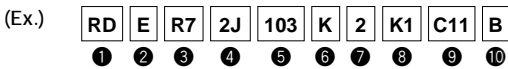

●Dimensions

Dimensions and Lead Style Code	Dimensions (mm)					
	L	W	W1	T	F	d
2K1/2M1	5.0	3.5	5.0	See the individual product specifications	5.0	0.5
3K1/3M1	5.0	4.5	6.3		5.0	0.5
5B1/5E1	7.5	7.5*	-		5.0	0.5
8K1/8M1	7.5	5.5	8.0		5.0	0.5
UB1/UE1	7.7	12.5*	-		5.0	0.5

*DC630V: W+0.5mm

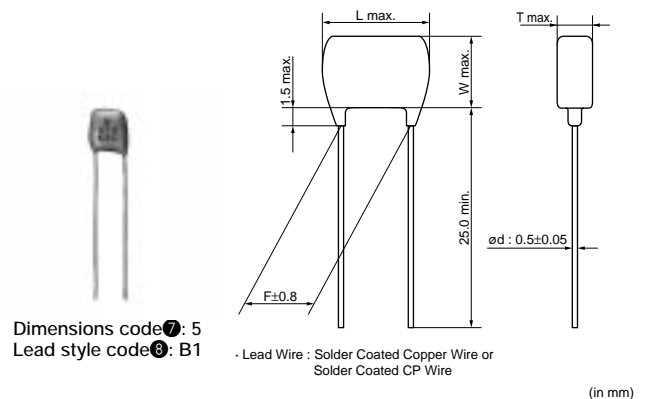
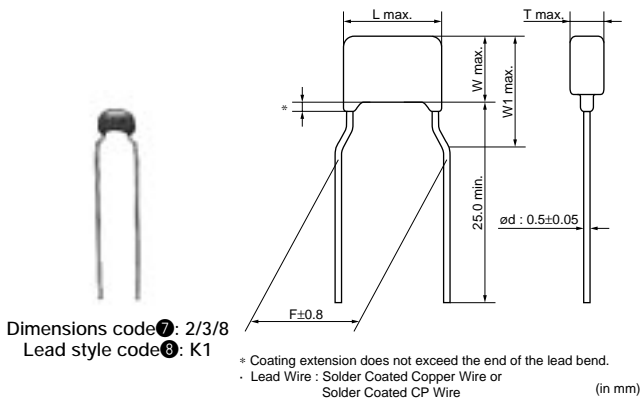

Continued on the following page. ↗

Continued from the preceding page.



Dimensions code **7**: U
Lead style code **6**: B1

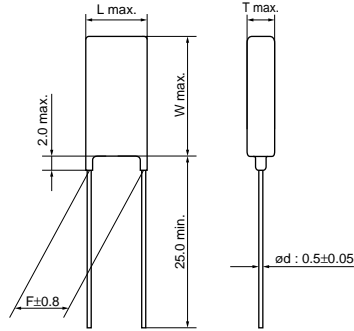

Lead Wire : Solder Coated Copper Wire or Solder Coated CP Wire

(in mm)

Part Number	TC	Rated Voltage (Vdc)	Capacitance	Dimensions LxW (mm)	Dimension T (mm)	Lead Space F (mm)	Lead Style Code Bulk	Lead Style Code Taping (1)	Lead Style Code Taping (2)
RDER72E102K2□□A11□	X7R	250	1000pF ±10%	5.0 x 3.5	3.15	5.0	K1	M1	-
RDER72E152K2□□A11□	X7R	250	1500pF ±10%	5.0 x 3.5	3.15	5.0	K1	M1	-
RDER72E222K2□□A11□	X7R	250	2200pF ±10%	5.0 x 3.5	3.15	5.0	K1	M1	-
RDER72E332K2□□A11□	X7R	250	3300pF ±10%	5.0 x 3.5	3.15	5.0	K1	M1	-
RDER72E472K2□□A11□	X7R	250	4700pF ±10%	5.0 x 3.5	3.15	5.0	K1	M1	-
RDER72E682K2□□A11□	X7R	250	6800pF ±10%	5.0 x 3.5	3.15	5.0	K1	M1	-
RDER72E103K2□□A11□	X7R	250	10000pF ±10%	5.0 x 3.5	3.15	5.0	K1	M1	-
RDER72E153K2□□C11□	X7R	250	15000pF ±10%	5.0 x 3.5	3.15	5.0	K1	M1	-
RDER72E223K2□□C11□	X7R	250	22000pF ±10%	5.0 x 3.5	3.15	5.0	K1	M1	-
RDER72E333K2□□C11□	X7R	250	33000pF ±10%	5.0 x 3.5	3.15	5.0	K1	M1	-
RDER72E473K2□□C11□	X7R	250	47000pF ±10%	5.0 x 3.5	3.15	5.0	K1	M1	-
RDER72E683K3□□C11□	X7R	250	68000pF ±10%	5.0 x 4.5	3.15	5.0	K1	M1	-
RDER72E104K3□□C11□	X7R	250	0.10μF ±10%	5.0 x 4.5	3.15	5.0	K1	B1	-
RDER72E154K8□□C11□	X7R	250	0.15μF ±10%	7.5 x 5.5	3.15	5.0	K1	M1	-
RDER72E224K8□□C11□	X7R	250	0.22μF ±10%	7.5 x 5.5	3.15	5.0	K1	M1	-
RDER72E334K5□□C13□	X7R	250	0.33μF ±10%	7.5 x 7.5	4.0	5.0	B1	E1	-
RDER72E474K5□□C13□	X7R	250	0.47μF ±10%	7.5 x 7.5	4.0	5.0	B1	E1	-
RDER72E105MU□□C13□	X7R	250	1.0μF ±20%	7.7 x 12.5	4.0	5.0	B1	E1	-
RDER72J102K2□□C11□	X7R	630	1000pF ±10%	5.0 x 3.5	3.15	5.0	K1	M1	-
RDER72J152K2□□C11□	X7R	630	1500pF ±10%	5.0 x 3.5	3.15	5.0	K1	M1	-
RDER72J222K2□□C11□	X7R	630	2200pF ±10%	5.0 x 3.5	3.15	5.0	K1	M1	-
RDER72J332K2□□C11□	X7R	630	3300pF ±10%	5.0 x 3.5	3.15	5.0	K1	M1	-
RDER72J472K2□□C11□	X7R	630	4700pF ±10%	5.0 x 3.5	3.15	5.0	K1	M1	-
RDER72J682K2□□C11□	X7R	630	6800pF ±10%	5.0 x 3.5	3.15	5.0	K1	M1	-
RDER72J103K2□□C11□	X7R	630	10000pF ±10%	5.0 x 3.5	3.15	5.0	K1	M1	-
RDER72J153K2□□C11□	X7R	630	15000pF ±10%	5.0 x 3.5	3.15	5.0	K1	M1	-
RDER72J223K3□□C11□	X7R	630	22000pF ±10%	5.0 x 4.5	3.15	5.0	K1	M1	-
RDER72J333K3□□C11□	X7R	630	33000pF ±10%	5.0 x 4.5	3.15	5.0	K1	M1	-
RDER72J473K3□□C11□	X7R	630	47000pF ±10%	5.0 x 4.5	3.15	5.0	K1	M1	-
RDER72J683K8□□C11□	X7R	630	68000pF ±10%	7.5 x 5.5	3.15	5.0	K1	M1	-
RDER72J104K8□□C11□	X7R	630	0.10μF ±10%	7.5 x 5.5	3.15	5.0	K1	M1	-
RDER72J154K5□□C13□	X7R	630	0.15μF ±10%	7.5 x 8.0	4.0	5.0	B1	E1	-
RDER72J224K5□□C13□	X7R	630	0.22μF ±10%	7.5 x 8.0	4.0	5.0	B1	E1	-
RDER72J474MU□□C13□	X7R	630	0.47μF ±20%	7.7 x 13.0	4.0	5.0	B1	E1	-

Two blank columns are filled with the lead style code. Please refer to the 3 columns on the right for the appropriate code.
The last blank column is filled with the packaging code. (B: bulk, A: ammo pack)
Operating Temperature Range: -55 to +125deg.

Note • This PDF catalog is downloaded from the website of Murata Manufacturing co., ltd. Therefore, it's specifications are subject to change or our products in it may be discontinued without advance notice. Please check with our sales representatives or product engineers before ordering.
• This PDF catalog has only typical specifications because there is no space for detailed specifications. Therefore, please approve our product specifications or transact the approval sheet for product specifications before ordering.

Disc Ceramic Capacitors

● Disc Ceramic Capacitors

Description	Series	Rated Voltage	Temp. Char.	Capacitance Range (pF)																		
				1	3	5	10	30	50	100	300	500	1000	3000	5000	10000	30000	50000	100000	300000	500000	
High Voltage Ceramic Capacitors	DES DEB DEC DEA DEH	DC250V to 6.3kV	SL	5 to 560																		
			D	100 to 4700																		
			B	100 to 6800																		
			R	150 to 10000																		
			C	330 to 4700																		
			E	1000 to 10000																		
			F	1000 to 10000																		
			DEF	6.3kVp-p	CH	2 to 10																
			SL	10 to 47																		
			Safety Standard Certified Ceramic Capacitors	KY KH KX DEJ	AC250V(r.m.s.)	SL	10 to 68															
						B	100 to 680															
						E	1000 to 4700															
F	4700 to 10000																					

● Typical Examples of Temperature Characteristics

● High Voltage Ceramic Capacitors/ Safety Standard Certified Ceramic Capacitors

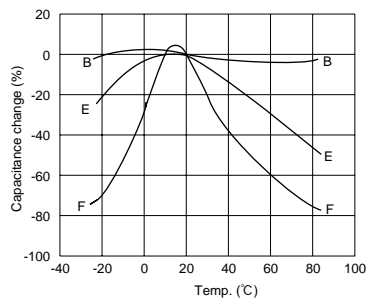
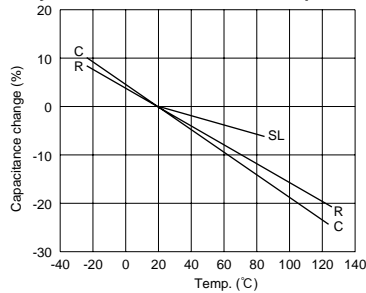

High Voltage Ceramic Capacitors (250V-6.3kV)

DEB Series

Vertical Crimp Long type (Lead Code: A*)

Straight Long type (Lead Code: C*)

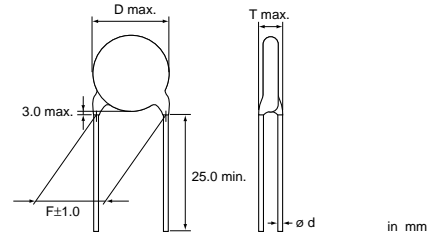
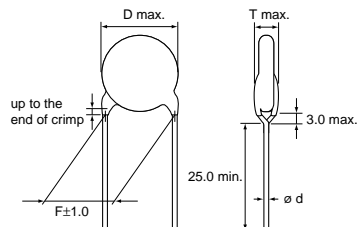

Operating Temp. Range -25°C to +85°C

● Part number configuration (Please see page 22 for details)

(Ex.)

DE	B	B3	3A	102	K	N2	A
①	②	③	④	⑤	⑥	⑦	⑧

Part Number	DC Rated Volt. (V)	Temp. Char. / ⑤ Capacitance Range (pF)			⑦ Lead Code and ⑧ Packaging Code		Dimensions (mm)								
		B	E	F	Bulk	Taping	D	F	T	ød					
Char. B : DEBB33A□□□K□□□ ⑤ ⑦ ⑧ Char. E : DEBE33A□□□Z□□□ ⑤ ⑦ ⑧ Char. F : DEBF33A□□□Z□□□ ⑤ ⑦ ⑧	1k	100 to 330	—	—	C1B	P2A	4.5	5	4	0.5±0.05 ¹⁾					
		470	1000	—			5								
		680, 1000	—	2200	A2B	N2A	6								
		—	2200	4700			7								
		1500	—	—			8								
		2200	4700	—			9								
		3300	—	10000			10								
		4700	—	—			A3B				N3A	12			
		—	10000	—	13										
		6800	—	—	15										
		Char. B : DEBB33D□□□K□□□ ⑤ ⑦ ⑧ Char. E : DEBE33D□□□Z□□□ ⑤ ⑦ ⑧ Char. F : DEBF33D□□□Z□□□ ⑤ ⑦ ⑧	2k	100 to 220	—	—	C1B				P2A	4.5	5	5	0.6±0.05
				330	—	1000						5			
470	1000			—	A2B	N2A	6								
680	—			2200			7								
1000	2200			—			8								
1500	—			4700			9								
2200	—			—			10								
—	4700			—			11								
3300	—			10000	A3B	N3A	12								
4700	—			—			15								
—	10000			—			16								
Char. B : DEBB33F□□□K□□□ ⑤ ⑦ ⑧ Char. E : DEBE33F□□□Z□□□ ⑤ ⑦ ⑧	3.15k			100 to 220	—	—	CDB	P3A	5	7.5	6	0.6±0.05			
		330	—	—	6										
		470	1000	—	C3B	N3A	7								
		680	—	—			8								
		1000	—	—	A3B	N3A	9								
		—	2200	—			10								
		1500	—	—			11								
		2200	4700	—			13								
		3300	—	—			N7A	N7A	15						
		—	—	—					15						
		Capacitance Tolerance		K	Z	Z	—								
		Capacitance Step		E6	E3	E3	—								

1) 0.6±0.05mm for Lead Code P2 and P3.

△Note • This PDF catalog is downloaded from the website of Murata Manufacturing co., ltd. Therefore, it's specifications are subject to change or our products in it may be discontinued without advance notice. Please check with our sales representatives or product engineers before ordering.
 • This PDF catalog has only typical specifications because there is no space for detailed specifications. Therefore, please approve our product specifications or transact the approval sheet for product specifications before ordering.

High Voltage Ceramic Capacitors (250V-6.3kV)

DEC Series

1
Capacitors

Vertical Crimp Long type
(Lead Code: A*)

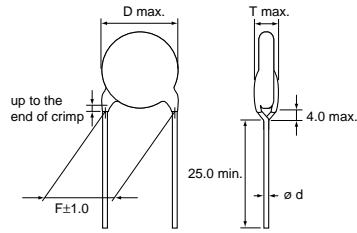

Straight Long type
(Lead Code: C*)

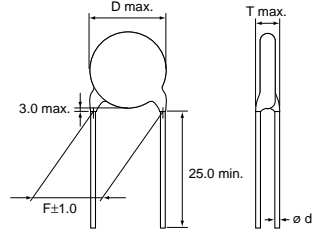

in mm

Operating Temp. Range -25°C to +85°C

●Part number configuration (Please see page 22 for details)

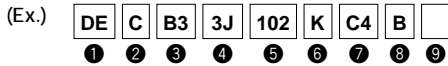

Part Number	Temp. Char.	DC Rated Volt. (V)	Cap. (pF)	Cap. Tol.	Dimensions (mm)						
					D	F	T	ød			
DEC1X3J100JA3BMS1	SL	6.3k	10	±5%	7	7.5	7	0.6±0.05			
DEC1X3J100JC4BMS1						10					
DEC1X3J120JA3B					8	7.5					
DEC1X3J120JC4B						10					
DEC1X3J150JA3B					8	7.5					
DEC1X3J150JC4B						10					
DEC1X3J180JA3B					9	7.5					
DEC1X3J180JC4B						10					
DEC1X3J220JA3B					9	7.5					
DEC1X3J220JC4B						10					
DEC1X3J270JA3B					9	7.5					
DEC1X3J270JC4B						10					
DEC1X3J330JA3B					9	7.5					
DEC1X3J330JC4B						10					
DEC1X3J390JA3B					9	7.5					
DEC1X3J390JC4B						10					
DEC1X3J470JA3B					10	7.5					
DEC1X3J470JC4B						10					
DEC1X3J560JC4B					10	10					
DEC1X3J680JC4B						12					
DEC1X3J820JC4B					10	13					
DEC1X3J101JC4B						14					
DEC1X3J121JC4B					9	15					
DEC1X3J151JC4B						10					
DECB33J101KC4B					B	150			±10%	9	10
DECB33J151KC4B						220					
DECB33J221KC4B	330										
DECB33J331KC4B	470										
DECB33J471KC4B	680										
DECB33J681KC4B	1000										
DECE33J102ZC4B	E	1000	+80% -20%	11	15						
DECE33J222ZC4B		2200									

High Voltage Ceramic Capacitors (250V-6.3kV)

DES Series



Vertical Crimp Long type
(Lead Code: A*)

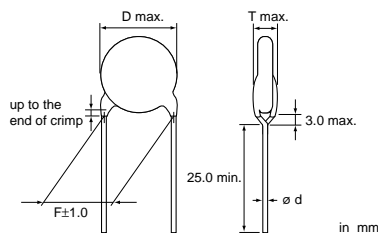

Operating Temp. Range -25°C to +125°C

●Part number configuration (Please see page 22 for details)

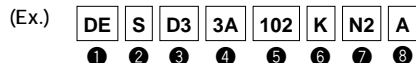

Part Number	DC Rated Volt. (V)	Cap. (pF)	Cap. Tol. (%)	⑦Lead Code and ⑧Packaging Code		Dimensions (mm)			
				Bulk	Taping	D	F	T	ød
DESD32H101K□□□	500	100	±10	A2B	N2A	6	5	4	0.6±0.05
DESD32H151K□□□		150							
DESD32H221K□□□		220							
DESD32H331K□□□		330							
DESD32H471K□□□		470							
DESD32H681K□□□		680							
DESD32H102K□□□		1000							
DESD32H152K□□□		1500							
DESD32H222K□□□		2200							
DESD32H332K□□□		3300							
DESD32H472K□□□	4700								
DESD33A101K□□□	1k	100	±10	A2B	N2A	6	5	4.5	0.6±0.05
DESD33A151K□□□		150							
DESD33A221K□□□		220							
DESD33A331K□□□		330							
DESD33A471K□□□		470							
DESD33A681K□□□		680							
DESD33A102K□□□		1000							
DESD33A152K□□□		1500							
DESD33A222K□□□		2200							
DESD33A332K□□□		3300							
DESD33A472K□□□	4700								
				A3B	N3A	12	7.5		
				A3B	N7A	14	7.5		
				A3B	N7A	17	7.5		

Three blank columns are filled with Lead Code and Packaging Code.

△Note • This PDF catalog is downloaded from the website of Murata Manufacturing co., ltd. Therefore, it's specifications are subject to change or our products in it may be discontinued without advance notice. Please check with our sales representatives or product engineers before ordering.
• This PDF catalog has only typical specifications because there is no space for detailed specifications. Therefore, please approve our product specifications or transact the approval sheet for product specifications before ordering.

High Voltage Ceramic Capacitors (250V-6.3kV)

DEA/DEH Series

1
Capacitors



Vertical Crimp Long type
(Lead Code: A*)

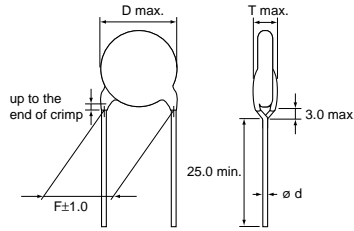

Straight Long type
(Lead Code: C*)

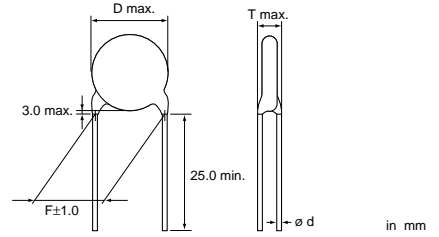

Operating Temp. Range -25°C to +125°C

●Part number configuration (Please see page 22 for details)

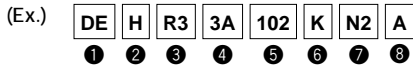

Part Number	DC Rated Volt. (V)	Temp. Char./⑤ Capacitance Range (pF)			⑦ Lead Code and ⑧ Packaging Code		Dimensions (mm)			
		SL (DEA Series)	R (DEH Series)	C (DEH Series)	Bulk	Taping	D	F	T	ød
Char. R : DEHR32E□□□K□□□ ⑤ ⑦ ⑧	250	---	220 to 1000	---	A2B	N2A	6	5	4	0.6±0.05
		---	1500	---			7			
		---	2200	---			8			
		---	3300	---			9			
		---	4700	---			10			
		---	6800, 10000	---			12			
Char. C : DEHC32H□□□K□□□ ⑤ ⑦ ⑧	500	---	---	330, 470	A2B	N2A	6	5	4	0.6±0.05
		---	---	680			7			
		---	---	1000			8			
		---	---	1500			9			
		---	---	2200			10			
		---	---	3300			12			
		---	---	4700			A4B			
Char. SL : DEA1X3A□□□J□□□ ⑤ ⑦ ⑧ Char. R : DEHR33A□□□K□□□ ⑤ ⑦ ⑧	1k	10 to 47	---	---	C1B	P2A	4.5	5	4	0.5±0.05 ¹⁾
		56, 68	---	---			5			
		82 to 120	---	---	A2B	N2A	6	5	4.5 ²⁾	0.6±0.05
		150, 180	220 to 470	---			7			
		220	680	---			8			
		270	1000	---			9			
		330, 390	---	---			10			
		470	1500	---			11			
		560	---	---			12			
		---	2200	---	A3B	N3A	13	7.5		
		---	3300	---			15			
		---	4700	---			17			

Continued on the following page.

Continued from the preceding page.

Part Number	DC Rated Volt. (V)	Temp. Char./⑤ Capacitance Range (pF)			⑦ Lead Code and ⑧ Packaging Code		Dimensions (mm)				
		SL (DEA Series)	R (DEH Series)	C (DEH Series)	Bulk	Taping	D	F	T	ød	
Char. SL : DEA1X3D□□□J□□□ ⑤ ⑦ ⑧ Char. R : DEHR33D□□□K□□□ ⑤ ⑦ ⑧	2k	10 to 33	---	---	C1B	P2A	4.5	5	5	0.5±0.05 ¹⁾	
		39	---	---			5				
		47 to 68	---	---	A2B	N2A	6				
		82, 100	---	---			7				
		120, 150	---	---			8				
		180	---	---			9				
		220	---	---			10				
		270	---	---			11				
		---	220, 270	---			C3B				P3A
		---	330, 390	---	A3B	N3A	8				
		---	470, 560	---			9				
		---	680	---			10				
		---	820	---			11				
		330	1000 to 1500	---			12				
		390	---	---			13				
		470	1800	---			14				
		560	2200	---			N7A	15			
		---	2700	---				17			
		---	3300	---				19			
		---	3900	---	A4B	---	20	10	7.5	6	0.6±0.05
		---	4700	---	---	21					
Char. SL : DEA1X3F□□□J□□□ ⑤ ⑦ ⑧ Char. R : DEHR33F□□□K□□□ ⑤ ⑦ ⑧	3.15k	10 to 22	---	---	CDB	P3A	5	7.5	6	0.5±0.05 ¹⁾	
		27 to 39	---	---	C3B		6				
		47, 56	150 to 270	---	A3B	N3A	7				
		68, 82	330	---			8				
		100	390	---			9				
		120	470, 560	---			10				
		150, 180	680	---			11				
		220	820	---			12				
		---	1000	---			13				
		270	1200	---			14				
		330	1500	---			N7A			15	
		390	1800	---						16	
		---	2200	---						17	
		---	2700	---						19	
		---	---	---			A4B			---	19
Capacitance Tolerance		J	K	K	---						
Capacitance Step		E12	E6 (250V to 1kV) E12 (2kV, 3.15kV)		---						

1) 0.6±0.05 mm for Lead Code P2 and P3.
2) 4mm for Characteristics SL.

High Voltage Ceramic Capacitors (6.3kVp-p)

DEF Series (LCD Backlight Inverter Circuit)

1
Capacitors

Vertical Crimp Long type
(Lead Code: A*)

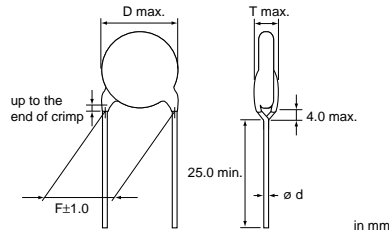

Operating Temp. Range -25°C to +105°C

●Part number configuration (Please see page 22 for details)

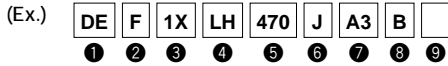

Part Number	Rated Volt. (Vp-p)	Cap. (pF)	Cap. Tol.	⑦Lead Code and ⑧Packaging Code		Dimensions (mm)			
				Bulk	Taping	D	F	T	ød
DEF2CLH020C□□□□	6.3k	2	±0.25pF	A3B	N3A	7	7.5	6	0.6±0.05
DEF2CLH030C□□□□		3							
DEF2CLH040C□□□□		4							
DEF2CLH050D□□□□		5							
DEF2CLH060D□□□□		6	±0.5pF			8			
DEF2CLH070D□□□□		7							
DEF2CLH080D□□□□		8							
DEF2CLH090D□□□□		9							
DEF2CLH100J□□□□		10	±5%			7			
DEF1XLH100J□□□□		10							
DEF1XLH120J□□□□		12							
DEF1XLH150J□□□□		15							
DEF1XLH180J□□□□		18							
DEF1XLH220J□□□□		22							
DEF1XLH270J□□□□		27							
DEF1XLH330J□□□□		33							
DEF1XLH390J□□□□		39							
DEF1XLH470J□□□□		47							

Three blank columns are filled with Lead Code and Packaging Code.

Safety Standard Certified Ceramic Capacitors

Type KY (Basic Insulation) —IEC60384-14 Class X1, Y2—

Vertical Crimp Long type
(Lead code: A2, A3)

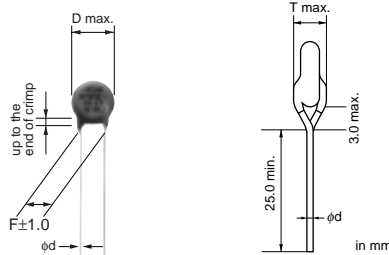

Operating Temp. Range -25°C to +125°C (Standard of UL : -25°C to +85°C)

	Standard No.	Rated Voltage
UL	UL1414	AC250V (r.m.s.)
CSA	E384-14	
BSI	EN 60065 (8.8, 14.2) EN 60384-14, IEC 60384-14	
SEMKO	EN 60384-14 IEC 60384-14	
ESTI		
VDE		
FIMKO		
NEMKO		
DEMKO	IEC 60384-14 AS3250	
NSW		

*Please contact us when the recognition of Chinese Safety Standard or South Korean Safety Standard is necessary.

●Part number configuration (Please see page 23 for details)

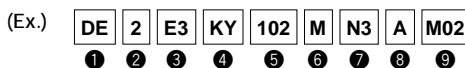

●Lead spacing F=7.5mm

Part Number	Temp. Char.	Cap. (pF)	Cap. Tol. (%)	⑦Lead Code and ⑧Packaging Code		Dimensions (mm)			
				Bulk	Taping	D	F	T	ød
DE21XKY100J□□□M02	SL	10	±5	A3B	N3A	8	7.5	5	0.6±0.05
DE21XKY150J□□□M02		15							
DE21XKY220J□□□M02		22							
DE21XKY330J□□□M02		33							
DE21XKY470J□□□M02		47							
DE21XKY680J□□□M02		68							
DE2B3KY101K□□□M02	B	100	±10			7	8		
DE2B3KY151K□□□M02		150							
DE2B3KY221K□□□M02		220							
DE2B3KY331K□□□M02		330							
DE2B3KY471K□□□M02		470							
DE2B3KY681K□□□M02		680							
DE2E3KY102M□□□M02	E	1000	±20			7	8		
DE2E3KY152M□□□M02		1500							
DE2E3KY222M□□□M02		2200							
DE2E3KY332M□□□M02		3300							
DE2E3KY472M□□□M02		4700							
DE2F3KY103M□□□M02		F						10000	

Dielectric Strength : AC2600V (r.m.s.), 60 s
 Three blank columns are filled with Lead Code and Packaging Code.
 Murata part numbers might be changed depending on lead code or any other changes.
 Therefore, please specify only the type name (KY) and capacitance of products in the parts list when it is required for applying safety standard of electric equipment.

●Lead spacing F=5mm

Part Number	Temp. Char.	Cap. (pF)	Cap. Tol. (%)	⑦Lead Code and ⑧Packaging Code		Dimensions (mm)			
				Bulk	Taping	D	F	T	ød
DE21XKY100J□□□M01	SL	10	±5	A2B	N2A	8	5	5	0.6±0.05
DE21XKY150J□□□M01		15							
DE21XKY220J□□□M01		22							
DE21XKY330J□□□M01		33							
DE21XKY470J□□□M01		47							
DE21XKY680J□□□M01		68							
DE2B3KY101K□□□M01	B	100	±10			7	8		
DE2B3KY151K□□□M01		150							
DE2B3KY221K□□□M01		220							
DE2B3KY331K□□□M01		330							
DE2B3KY471K□□□M01		470							
DE2B3KY681K□□□M01		680							
DE2E3KY102M□□□M01	E	1000	±20			7	8		
DE2E3KY152M□□□M01		1500							
DE2E3KY222M□□□M01		2200							
DE2E3KY332M□□□M01		3300							
DE2E3KY472M□□□M01		4700							
DE2E3KY472M□□□M01									

Dielectric Strength : AC2000V (r.m.s.), 60 s
 Three blank columns are filled with Lead Code and Packaging Code.
 Murata part numbers might be changed depending on lead code or any other changes.
 Therefore, please specify only the type name (KY) and capacitance of products in the parts list when it is required for applying safety standard of electric equipment.

△Note • This PDF catalog is downloaded from the website of Murata Manufacturing co., ltd. Therefore, it's specifications are subject to change or our products in it may be discontinued without advance notice. Please check with our sales representatives or product engineers before ordering.
 • This PDF catalog has only typical specifications because there is no space for detailed specifications. Therefore, please approve our product specifications or transact the approval sheet for product specifications before ordering.

Safety Standard Certified Ceramic Capacitors

Type KH (Basic Insulation) —IEC60384-14 Class X1, Y2—

1
Capacitors

Vertical Crimp Long type
(Lead code: A3)

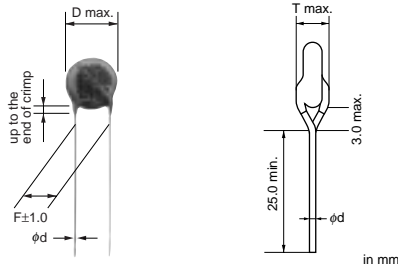

Operating Temp. Range -25°C to +125°C (Standard of UL : -25°C to +85°C)

	Standard No.	Rated Voltage
UL	UL1414	AC250V (r.m.s.)
CSA	E384-14	
BSI	EN 60065 (8.8, 14.2) EN 60384-14, IEC 60384-14	
SEMKO	EN 60384-14 IEC 60384-14	
ESTI		
VDE		
FIMKO		
NEMKO		
DEMKO	IEC 60384-14 AS3250	
NSW		

*Please contact us when the recognition of Chinese Safety Standard or South Korean Safety Standard is necessary.

●Part number configuration (Please see page 23 for details)



Part Number	Temp. Char.	Cap. (pF)	Cap. Tol. (%)	⑦Lead Code and ⑧Packaging Code		Dimensions (mm)									
				Bulk	Taping	D	F	T	φd						
DE2B3KH101K□□□	B	100	±10	A3B	N3A	8	7.5	7	0.6±0.05						
DE2B3KH151K□□□		150													
DE2B3KH221K□□□		220													
DE2B3KH331K□□□		330													
DE2B3KH471K□□□		470													
DE2B3KH681K□□□		680													
DE2E3KH102M□□□	E	1000	±20			A3B	N3A	8		7.5	7	0.6±0.05			
DE2E3KH152M□□□		1500													
DE2E3KH222M□□□		2200													
DE2E3KH332M□□□		3300													
DE2E3KH472M□□□		4700													
DE2F3KH103M□□□	F	10000						A3B		N7A	16				0.6±0.05

Dielectric Strength : AC2600V (r.m.s.), 60 s

Three blank columns are filled with Lead Code and Packaging Code.

Murata part numbers might be changed depending on lead code or any other changes.

Therefore, please specify only the type name (KH) and capacitance of products in the parts list when it is required for applying safety standard of electric equipment.

Safety Standard Certified Ceramic Capacitors

Type KX Small Size (Reinforced Insulation) —IEC60384-14 Class X1, Y1—

Vertical Crimp Long type
(Lead code: A4)

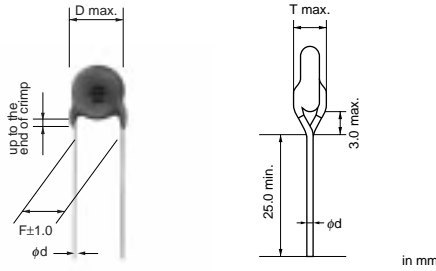

	Standard No.	Rated Voltage
UL	UL1414	AC250V (r.m.s.)
CSA	E384-14	
BSI	EN 60065 (8.8, 14.2) EN 60384-14, IEC 60384-14	
SEMKO	EN 60384-14 IEC 60384-14	
ESTI		
VDE		
FIMKO		
NEMKO		
DEMKO		
IMQ	EN 60384-14	

Operating Temp. Range -25°C to +125°C (Standard of UL : -25°C to +85°C)

* Small sized Type KX differs from current Type KX in electrical characteristics, such as the voltage dependency, of capacitance temperature dependency, and Dielectric strength.

Therefore, before replacing current Type KX, please make a performance check by equipment.

*Please contact us when the recognition of Chinese Safety Standard or South Korean Safety Standard is necessary.

●Part number configuration (Please see page 23 for details)

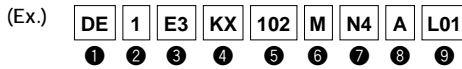

Part Number	Temp. Char.	Cap. (pF)	Cap. Tol. (%)	⑦Lead Code and ⑧Packaging Code		Dimensions (mm)			
				Bulk	Taping	D	F	T	ød
DE1B3KX101K□□□L01	B	100	±10	A4B	N4A	8	10	7	0.6±0.05
DE1B3KX151K□□□L01		150							
DE1B3KX221K□□□L01		220							
DE1B3KX331K□□□L01		330							
DE1B3KX471K□□□L01		470							
DE1B3KX681K□□□L01		680							
DE1E3KX102M□□□L01	E	1000	±20			12			
DE1E3KX152M□□□L01		1500							
DE1E3KX222M□□□L01		2200							
DE1E3KX332M□□□L01		3300							
DE1E3KX472M□□□L01		4700							

Dielectric Strength : AC4000V (r.m.s.), 60 s

Three blank columns are filled with Lead Code and Packaging Code. Individual specification code "L01" expresses small size.

Murata part numbers might be changed depending on lead code or any other changes.

Therefore, please specify only the type name (KX) and capacitance of products in the parts list when it is required for applying safety standard of electric equipment.

Safety Standard Certified Ceramic Capacitors

Type KX (Reinforced Insulation) —IEC60384-14 Class X1, Y1—

1
Capacitors

Vertical Crimp Long type
(Lead code: A5)

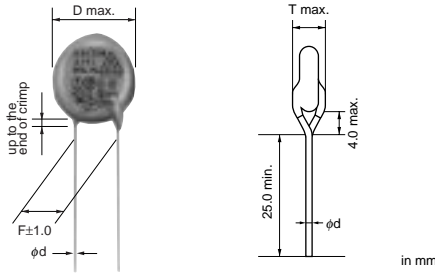

	Standard No.	Rated Voltage
UL	UL1414	AC250V (r.m.s.)
CSA	E384-14	
BSI	EN 60065 (8.8, 14.2) EN 60384-14, IEC 60384-14	
SEMKO	EN 60384-14 IEC 60384-14	
ESTI		
VDE		
FIMKO		
NEMKO		
DEMKO		
IMQ	EN 60384-14	

Operating Temp. Range -25°C to +125°C (Standard of UL : -25°C to +85°C)

*Please contact us when the recognition of Chinese Safety Standard or South Korean Safety Standard is necessary.

●Part number configuration (Please see page 23 for details)

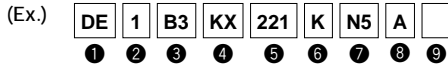

Part Number	Temp. Char.	Cap. (pF)	Cap. Tol. (%)	⑦Lead Code and ⑧Packaging Code		Dimensions (mm)			
				Bulk	Taping	D	F	T	φd
DE11XKX100J□□□	SL	10	±5	A5B	N5A	9	10	8	0.6 ^{+0.1} _{-0.05}
DE11XKX150J□□□		15							
DE11XKX220J□□□		22							
DE11XKX330J□□□		33							
DE11XKX470J□□□		47							
DE11XKX680J□□□		68							
DE1B3KX101K□□□	B	100	±10						
DE1B3KX151K□□□		150							
DE1B3KX221K□□□		220							
DE1B3KX331K□□□		330							
DE1B3KX471K□□□		470							
DE1B3KX681K□□□		680							
DE1E3KX102M□□□A01	E	1000	±20						
DE1E3KX152M□□□A01		1500							
DE1E3KX222M□□□A01		2200							
DE1E3KX332M□□□A01		3300							
DE1E3KX392M□□□A01		3900							
DE1E3KX472M□□□A01		4700							

Dielectric Strength : AC4000V (r.m.s.), 60 s

Three blank columns are filled with Lead Code and Packaging Code.

Murata part numbers might be changed depending on lead code or any other changes.

Therefore, please specify only the type name (KX) and capacitance of products in the parts list when it is required for applying safety standard of electric equipment.

Safety Standard Certified Ceramic Capacitors

DEJ Series—Products which are Based on the Electrical Appliance and Material Safety Law of Japan—



Vertical Crimp Long type
(Lead Code: A*)

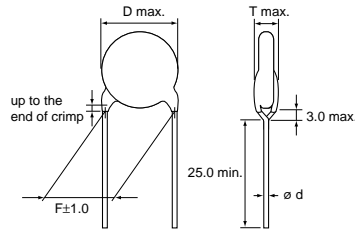

Straight Long type
(Lead Code: C*)

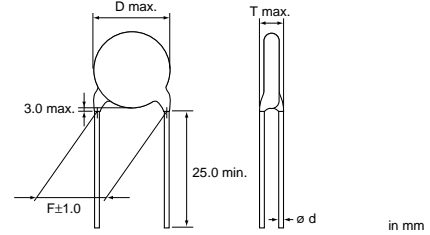

Operating Temp. Range -25°C to +85°C

● Part number configuration (Please see page 23 for details)

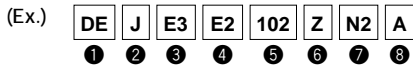

Part Number	Temp. Char.	Cap. (pF)	Cap. Tol. (%)	⑦ Lead Code and ⑧ Packaging Code			Dimensions (mm)			
				Bulk	Taping		D	F	T	ød
DEJE3E2102Z□□□	E	1000	+80 -20	A3B	N2A	N3A	7	7.5 ¹⁾	4	0.6±0.05
DEJE3E2222Z□□□		8								
DEJE3E2332Z□□□		9								
DEJE3E2472Z□□□		11								
DEJF3E2472Z□□□	F	4700					8			
DEJF3E2103Z□□□		10000					11			

Dielectric Strength : AC1500V (r.m.s.), 60 s

1) 5mm for Lead Code N2

Three blank columns are filled with Lead Code and Packaging Code.

● Minimum Quantity (order in sets only)/Minimum Order Quantity

		Minimum Quantity	Minimum Order Quantity	
High-Voltage Ceramic Capacitors/ Safety Standard Certified Ceramic Capacitors	Bulk	1,000	3,000	
	Lead Code	P2, N2	1,500 ¹⁾	3,000
		P3, N3	1,000 ²⁾	3,000 ³⁾
		N7	500 ⁴⁾	2,000
		N4, N5	500	2,000

1) 1,000 pcs. for Type KY.

2) 900 pcs. for 2kV and 3.15kV rated voltages, DEF Series and Type KH/KY.

3) 2,700 pcs. for 2kV and 3.15kV rated voltages, DEF Series and Type KH/KY.

4) 400 pcs. for Type KH.

△Note • This PDF catalog is downloaded from the website of Murata Manufacturing co., ltd. Therefore, it's specifications are subject to change or our products in it may be discontinued without advance notice. Please check with our sales representatives or product engineers before ordering.
• This PDF catalog has only typical specifications because there is no space for detailed specifications. Therefore, please approve our product specifications or transact the approval sheet for product specifications before ordering.

High Voltage Ceramic Capacitors (10-40kV)

● Typical Example of Temperature Characteristics

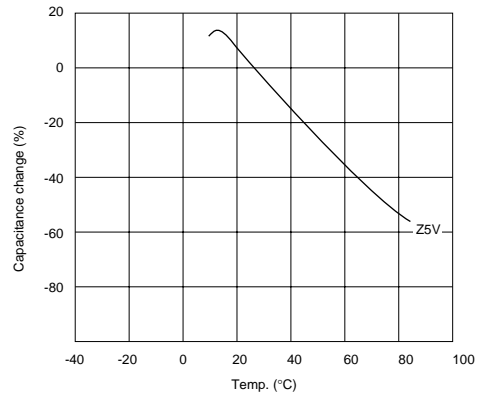
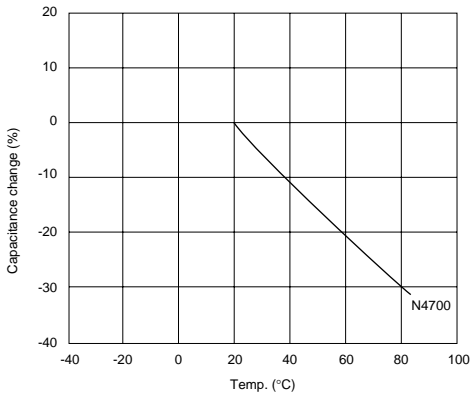

High Voltage Ceramic Capacitors (10-40kV)

DHS Series

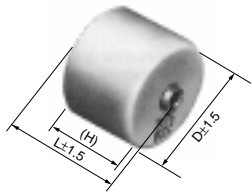

in mm

Operating Temp. Range -20°C to +85°C

● Part number configuration (Please see page 24 for details)

(Ex.)

DH	S	4E	4D	142	K	LX	B
①	②	③	④	⑤	⑥	⑦	⑧

Note • This PDF catalog is downloaded from the website of Murata Manufacturing co., Ltd. Therefore, its specifications are subject to change or our products in it may be discontinued without advance notice. Please check with our sales representatives or product engineers before ordering.
• This PDF catalog has only typical specifications because there is no space for detailed specifications. Therefore, please approve our product specifications or transact the approval sheet for product specifications before ordering.

●DHS N4700 Series

Part Number	Capacitance (pF)	Capacitance Tolerance (%)	DC Rated Voltage (kV)	Dimensions (mm)			Terminal Type (Screw Thread Type)	
				D	L	H		
DHS4E4A561KC2B	560	±10	10	20	16	12	ISO M4, P0.7 (Metric Screw Thread)	
DHS4E4A122KH2B	1200			30				
DHS4E4A282KL2B	2800			38				
DHS4E4A502KR2B	5000			52				
DHS4E4A802KT2B	8000			60				
DHS4E4A561MCXB	560	±20		20	16	12		No.8-32, NC-2B (Inch Screw Thread)
DHS4E4A122MHXB	1200			30				
DHS4E4A282MLXB	2800			38				
DHS4E4A502MRXB	5000			52				
DHS4E4A802MTXB	8000			60				
DHS4E4C371KC2B	370	±10	15	20	18	14	ISO M4, P0.7 (Metric Screw Thread)	
DHS4E4C112KH2B	1100			30				
DHS4E4C192KL2B	1900			38				
DHS4E4C342KR2B	3400			52				
DHS4E4C532KT2B	5300			60				
DHS4E4C371MCXB	370	±20		20	18	14		No.8-32, NC-2B (Inch Screw Thread)
DHS4E4C112MHXB	1100			30				
DHS4E4C192MLXB	1900			38				
DHS4E4C342MRXB	3400			52				
DHS4E4C532MTXB	5300			60				
DHS4E4D281KC2B	280	±10	20	20	24	20	ISO M4, P0.7 (Metric Screw Thread)	
DHS4E4D881KH2B	880			30				
DHS4E4D142KL2B	1400			38				
DHS4E4D252KR2B	2500			52				
DHS4E4D402KT2B	4000			60				
DHS4E4D281MCXB	280	±20		20	24	20		No.8-32, NC-2B (Inch Screw Thread)
DHS4E4D881MHXB	880			30				
DHS4E4D142MLXB	1400			38				
DHS4E4D252MRXB	2500			52				
DHS4E4D402MTXB	4000			60				
DHS4E4F191KC2B	190	±10	30	20	28	24	ISO M4, P0.7 (Metric Screw Thread)	
DHS4E4F591KH2B	590			30				
DHS4E4F941KL2B	940			38				
DHS4E4F172KR2B	1700			52				
DHS4E4F272KT2B	2700			60				
DHS4E4F191MCXB	190	±20		20	28	24		No.8-32, NC-2B (Inch Screw Thread)
DHS4E4F591MHXB	590			30				
DHS4E4F941MLXB	940			38				
DHS4E4F172MRXB	1700			52				
DHS4E4F272MTXB	2700			60				
DHS4E4G141KC2B	140	±10	40	20	36	32	ISO M4, P0.7 (Metric Screw Thread)	
DHS4E4G441KH2B	440			30				
DHS4E4G701KL2B	700			38				
DHS4E4G132KR2B	1300			52				
DHS4E4G202KT2B	2000			60				
DHS4E4G141MCXB	140	±20		20	36	32		No.8-32, NC-2B (Inch Screw Thread)
DHS4E4G441MHXB	440			30				
DHS4E4G701MLXB	700			38				
DHS4E4G132MRXB	1300			52				
DHS4E4G202MTXB	2000			60				

● DHS Z5V Series

Part Number	Capacitance (pF)	Capacitance Tolerance (%)	DC Rated Voltage (kV)	Dimensions (mm)			Terminal Type (Screw Thread Type)					
				D	L	H						
DHSF44D601ZD2B	600	+80, -20	20	24	26	24	ISO M4, P0.7 (Metric Screw Thread)					
DHSF44D102ZH2B	1000			30								
DHSF44D242ZN2B	2400			43								
DHSF44D332ZR2B	3300			52								
DHSF44D482ZT2B	4800			60								
DHSF44D601ZDXB	600			24								
DHSF44D102ZHXB	1000			30								
DHSF44D242ZNXB	2400			43								
DHSF44D332ZRXB	3300			52								
DHSF44D482ZTXB	4800			60								
DHSF44F461ZD2B	460			30				34	32	32	ISO M4, P0.7 (Metric Screw Thread)	
DHSF44F781ZH2B	780											24
DHSF44F182ZN2B	1800		30									
DHSF44F252ZR2B	2500		43									
DHSF44F362ZT2B	3600		52									
DHSF44F461ZDXB	460		60									
DHSF44F781ZHXB	780		24									
DHSF44F182ZNXB	1800		30									
DHSF44F252ZRXB	2500		43									
DHSF44F362ZTXB	3600		52									
DHSF44G341ZD2B	340		40		41	39	39					ISO M4, P0.7 (Metric Screw Thread)
DHSF44G571ZH2B	570											
DHSF44G132ZN2B	1300			30								
DHSF44G192ZR2B	1900			43								
DHSF44G272ZT2B	2700	52										
DHSF44G341ZDXB	340	60										
DHSF44G571ZHXB	570	24										
DHSF44G132ZNXB	1300	30										
DHSF44G192ZRXB	1900	43										
DHSF44G272ZTXB	2700	52										
DHSF44G272ZTXB	2700	60										

● Applications

- Lasers
- High Voltage DC power supplies

Ceramic Trimmer Capacitors

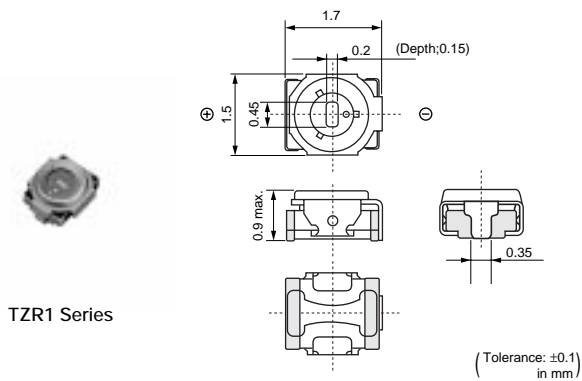

TZR1 Series

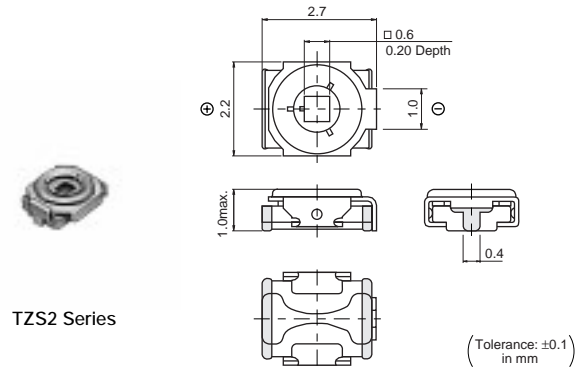

TZS2 Series

● TZR1 Series

Part Number	Cmin. (max.) (pF)	Cmax. (pF)	TC	Q	Rated Voltage	Withstanding Voltage
TZR1Z010A001	0.55	1.0 +100/-0%	NP0±300ppm/°C	200min. at 200MHz, Cmax.	25Vdc	55Vdc
TZR1Z1R5A001	0.7	1.5 +100/-0%	NP0±300ppm/°C	200min. at 200MHz, Cmax.	25Vdc	55Vdc
TZR1Z040A001	1.5	4.0 +100/-0%	NP0±500ppm/°C	300min. at 1MHz, Cmax.	25Vdc	55Vdc
TZR1R080A001	3.0	8.0 +100/-0%	N750±500ppm/°C	300min. at 1MHz, Cmax.	25Vdc	55Vdc

Insulation Resistance: 10000M ohm Torque: 0.1 to 1.0mNm Operating Temperature Range: -25 to +85°C

● TZS2 Series

Part Number	Cmin. (max.) (pF)	Cmax. (pF)	TC	Q	Rated Voltage	Withstanding Voltage
TZS2Z060A001	3.0	6.0 +100/-0%	NP0±300ppm/°C	500min. at 1MHz, Cmax.	25Vdc	55Vdc
TZS2Z100A001	3.5	10.0 +100/-0%	NP0±300ppm/°C	500min. at 1MHz, Cmax.	25Vdc	55Vdc
TZS2R200A001	7.0	20.0 +100/-0%	N750±500ppm/°C	500min. at 1MHz, Cmax.	25Vdc	55Vdc

Insulation Resistance: 10000M ohm Torque: 0.7 to 4.9mNm Operating Temperature Range: -25 to +85°C

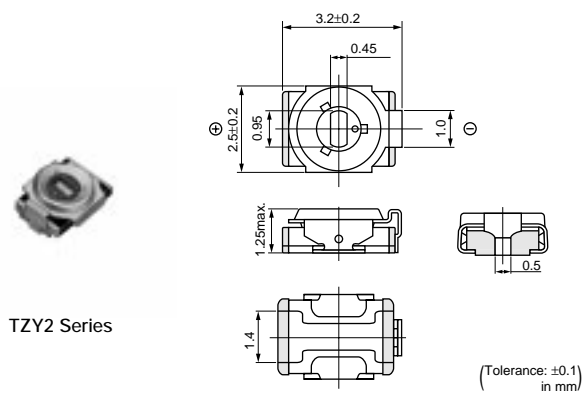

TZY2 Series

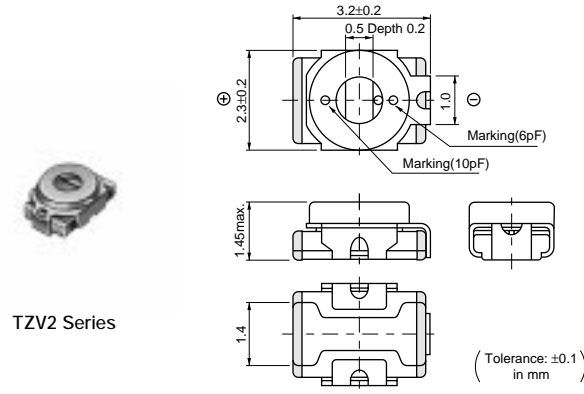

TZV2 Series

● TZY2 Series

Part Number	Cmin. (max.) (pF)	Cmax. (pF)	TC	Q	Rated Voltage	Withstanding Voltage
TZY2Z010A001	0.5	1.0 +100/-0%	NP0±300ppm/°C	200min. at 200MHz, Cmax.	25Vdc	55Vdc
TZY2Z2R5A001	0.65	2.5 +100/-0%	NP0±300ppm/°C	200min. at 200MHz, Cmax.	25Vdc	55Vdc
TZY2Z030A001	1.5	3.0 +100/-0%	NP0±300ppm/°C	300min. at 1MHz, Cmax.	25Vdc	55Vdc
TZY2Z060A001	2.5	6.0 +100/-0%	NP0±300ppm/°C	500min. at 1MHz, Cmax.	25Vdc	55Vdc

Continued on the following page. ↗

△Note • This PDF catalog is downloaded from the website of Murata Manufacturing co., ltd. Therefore, it's specifications are subject to change or our products in it may be discontinued without advance notice. Please check with our sales representatives or product engineers before ordering.
• This PDF catalog has only typical specifications because there is no space for detailed specifications. Therefore, please approve our product specifications or transact the approval sheet for product specifications before ordering.

Continued from the preceding page.

Part Number	Cmin. (max.) (pF)	Cmax. (pF)	TC	Q	Rated Voltage	Withstanding Voltage
TZY2Z100A001	3.0	10.0 +100/-0%	NP0±300ppm/°C	500min. at 1MHz, Cmax.	25Vdc	55Vdc
TZY2R200A001	4.5	20.0 +100/-0%	N750±500ppm/°C	500min. at 1MHz, Cmax.	25Vdc	55Vdc
TZY2R250A001	5.5	25.0 +100/-0%	N750±500ppm/°C	300min. at 1MHz, Cmax.	25Vdc	55Vdc
TZY2K450A001	8.0	45.0 +100/-0%	N1000±500ppm/°C	300min. at 1MHz, Cmax.	25Vdc	55Vdc

Insulation Resistance: 10000M ohm Torque: 0.7 to 4.9mNm Operating Temperature Range: -25 to +85°C

● TZV2 Series

Part Number	Cmin. (max.) (pF)	Cmax. (pF)	TC	Q	Rated Voltage	Withstanding Voltage
TZV2Z2R5A110	0.65	2.5 +100/-0%	NP0±300ppm/°C	200min. at 200MHz, Cmax.	25Vdc	55Vdc
TZV2Z030A110	1.5	3.0 +100/-0%	NP0±300ppm/°C	300min. at 1MHz, Cmax.	25Vdc	55Vdc
TZV2Z060A110	2.5	6.0 +100/-0%	NP0±300ppm/°C	500min. at 1MHz, Cmax.	25Vdc	55Vdc
TZV2Z100A110	3.0	10.0 +100/-0%	NP0±300ppm/°C	500min. at 1MHz, Cmax.	25Vdc	55Vdc
TZV2R200A110	4.5	20.0 +100/-0%	N750±500ppm/°C	500min. at 1MHz, Cmax.	25Vdc	55Vdc

Insulation Resistance: 10000M ohm Torque: 1.0 to 9.8mNm Operating Temperature Range: -25 to +85°C

● TZC3 Series

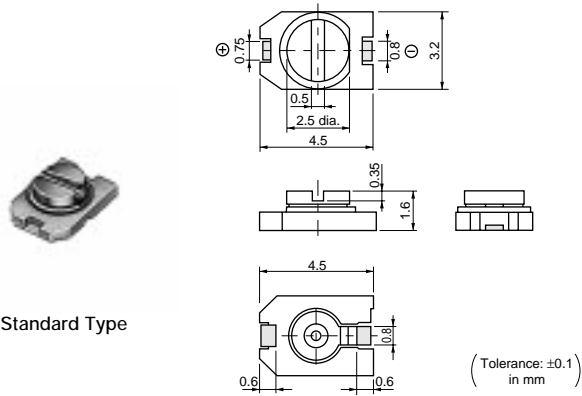

Part Number	Cmin. (max.) (pF)	Cmax. (pF)	TC	Q	Rated Voltage	Withstanding Voltage	Stator/Case Color
TZC3Z030A110	1.4	3.0 +50/-0%	NP0±300ppm/°C	300min. at 1MHz, Cmax.	100Vdc	220Vdc	Brown
TZC3Z060A110	2.0	6.0 +50/-0%	NP0±300ppm/°C	500min. at 1MHz, Cmax.	100Vdc	220Vdc	Blue
TZC3R100A110	3.0	10.0 +50/-0%	N750±300ppm/°C	500min. at 1MHz, Cmax.	100Vdc	220Vdc	White
TZC3P200A110	5.0	20.0 +50/-0%	N1200±500ppm/°C	300min. at 1MHz, Cmax.	100Vdc	220Vdc	Red
TZC3P300A110	6.5	30.0 +50/-0%	N1200±500ppm/°C	300min. at 1MHz, Cmax.	100Vdc	220Vdc	Green

Insulation Resistance: 10000M ohm Torque: 1.5 to 9.8mNm Operating Temperature Range: -25 to +85°C

● TZB4 Series

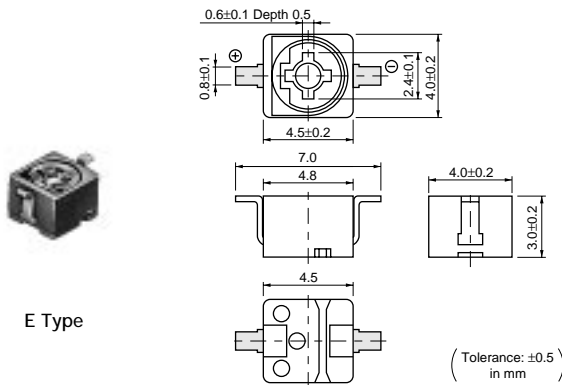
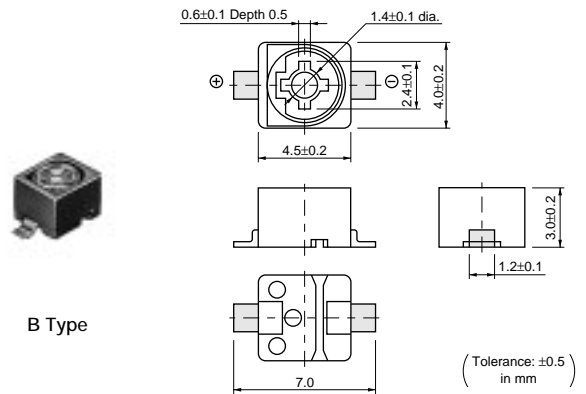
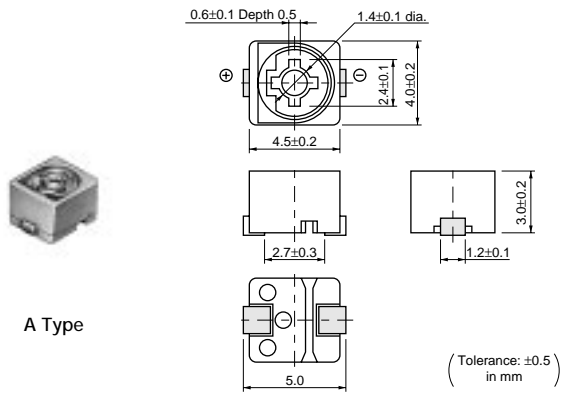

Part Number	Cmin. (max.) (pF)	Cmax. (pF)	TC	Q	Rated Voltage	Withstanding Voltage	Stator/Case Color
TZB4Z030□□10	1.4	3.0 +50/-0%	NP0±200ppm/°C	300min. at 1MHz, Cmax	100Vdc	220Vdc	Brown
TZB4Z060□□10	2.0	6.0 +50/-0%	NP0±200ppm/°C	500min. at 1MHz, Cmax.	100Vdc	220Vdc	Blue
TZB4Z100□□10	3.0	10.0 +50/-0%	NP0±300ppm/°C	500min. at 1MHz, Cmax.	100Vdc	220Vdc	White
TZB4R200□□10	4.5	20.0 +50/-0%	N750±400ppm/°C	500min. at 1MHz, Cmax	100Vdc	220Vdc	Red
TZB4P300□□10	6.5	30.0 +50/-0%	N1200±500ppm/°C	300min. at 1MHz, Cmax	100Vdc	220Vdc	Green
TZB4P400□□10	8.5	40.0 +50/-0%	N1200±500ppm/°C	300min. at 1MHz, Cmax	100Vdc	220Vdc	Yellow
TZB4Z250□□10	4.0	25.0 +100/-0%	NP0±300ppm/°C	300min. at 1MHz, Cmax.	50Vdc	110Vdc	Black+Marking
TZB4R500□□10	7.0	50.0 +100/-0%	N750±300ppm/°C	300min. at 1MHz, Cmax	50Vdc	110Vdc	Black+Marking

Insulation Resistance: 10000M ohm Torque: 1.5 to 9.8mNm Operating Temperature Range: -25 to +85°C

First blank: Terminal Type (A or B: Top Adjustment, E:Rear Adjustment) Second blank: Cover film codes (A: not provided, B: provided)

ex. TZB4Z100AB10: Terminal Type is A, and Cover film is provided.

● TZW4 Series

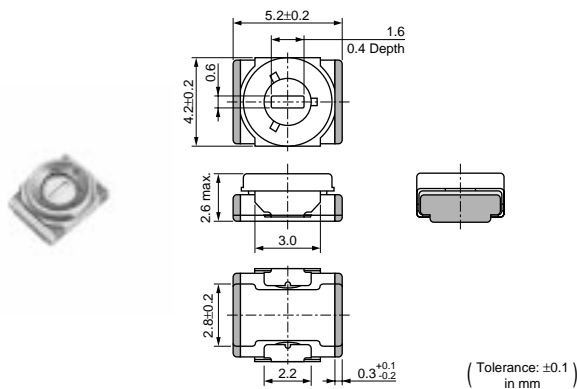

△Note • This PDF catalog is downloaded from the website of Murata Manufacturing co., ltd. Therefore, it's specifications are subject to change or our products in it may be discontinued without advance notice. Please check with our sales representatives or product engineers before ordering.
• This PDF catalog has only typical specifications because there is no space for detailed specifications. Therefore, please approve our product specifications or transact the approval sheet for product specifications before ordering.

Part Number	Cmin. (max.) (pF)	Cmax. (pF)	TC	Q	Rated Voltage	Withstanding Voltage
TZW4Z010A001	0.4	1.0 +50/-0%	NP0±150ppm/°C	200min. at 500MHz, Cmax.	250Vdc	550Vdc
TZW4Z1R5A001	0.4	1.5 +100/-0%	NP0±150ppm/°C	200min. at 500MHz, Cmax.	250Vdc	550Vdc

Insulation Resistance: 10000M ohm Torque: 1.5 to 10.0mNm Operating Temperature Range: -55 to +125°C

● TZ03 Series

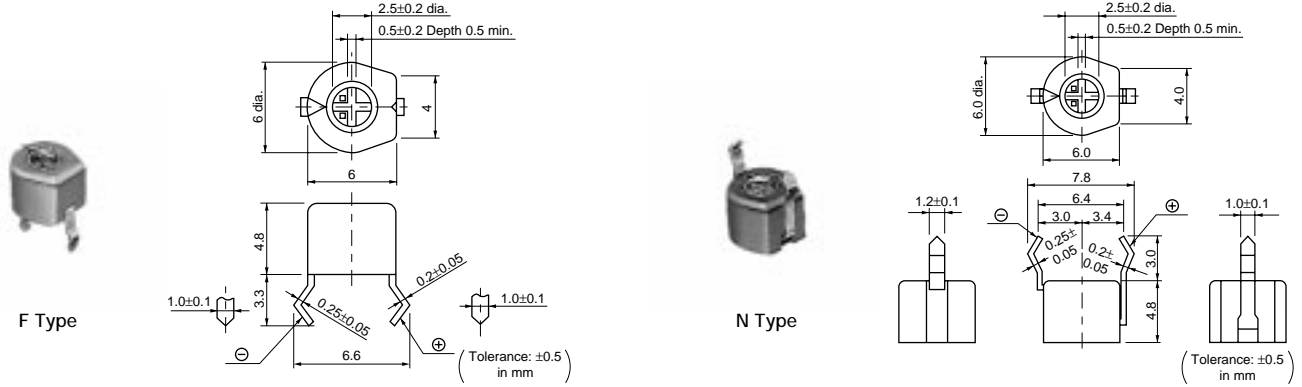

Part Number	Cmin. (max.) (pF)	Cmax. (pF)	TC	Q	Rated Voltage	Withstanding Voltage	Stator/Case Color
TZ03Z2R3□169	1.25	2.3 +50/-0%	NP0±200ppm/°C	300min. at 1MHz, Cmax.	100Vdc	220Vdc	Black
TZ03Z050□169	1.5	5.0 +50/-0%	NP0±200ppm/°C	500min. at 1MHz, Cmax.	100Vdc	220Vdc	Blue
TZ03Z070□169	2.0	7.0 +50/-0%	NP0±200ppm/°C	500min. at 1MHz, Cmax.	100Vdc	220Vdc	Blue
TZ03Z100□169	2.7	10.0 +50/-0%	NP0±200ppm/°C	500min. at 1MHz, Cmax.	100Vdc	220Vdc	Blue
TZ03R200□169	4.2	20.0 +50/-0%	N750±300ppm/°C	500min. at 1MHz, Cmax.	100Vdc	220Vdc	Red
TZ03R300□169	5.2	30.0 +50/-0%	N750±300ppm/°C	500min. at 1MHz, Cmax.	100Vdc	220Vdc	Green
TZ03P450□169	6.8	45.0 +50/-0%	N1200±500ppm/°C	300min. at 1MHz, Cmax.	100Vdc	220Vdc	Yellow
TZ03P600□169	9.8	60.0 +50/-0%	N1200±500ppm/°C	300min. at 1MHz, Cmax.	100Vdc	220Vdc	Brown
TZ03Z500□169	6.0	50.0 +100/-0%	NP0±300ppm/°C	300min. at 1MHz, Cmax.	50Vdc	110Vdc	Orange
TZ03R900□169	9.0	90.0 +100/-0%	N750±300ppm/°C	300min. at 1MHz, Cmax.	50Vdc	110Vdc	Black+Dot
TZ03R121□169	10.0	120.0 +100/-0%	N750±300ppm/°C	300min. at 1MHz, Cmax.	50Vdc	110Vdc	Black

Insulation Resistance: 10000M ohm Torque: 2.0 to 14.7mNm Operating Temperature Range: -25 to +85°C

A blank column is filled with terminal type codes (F: Top Adjustment, N: Rear Adjustment).

2

Noise Suppression Products/ EMI Suppression Filters

EMIFIL[®] (Inductor Type)

EMIFIL[®] (Capacitor Type)

EMIFIL[®] (LC Combined)

EMIFIL[®] (RC Combined)

Common Mode Choke Coil

Leaded EMIFIL[®] (Inductor Type)

Leaded EMIFIL[®] (Capacitor Type)

Block Type EMFIL[®] (LC Combined)

Leaded Common Mode Choke Coil

EMIGUARD[®] (EMIFIL[®] with Varistor Function)

AC Line Filters

Microwave Absorber

Ferrite Cores for EMI Suppression

● Part Numbering

Chip Ferrite Bead

(Part Number) **BL M 18 AG 102 S N 1 D**
① ② ③ ④ ⑤ ⑥ ⑦ ⑧ ⑨

- ① Product ID
- ② Type
- ③ Dimensions (L×W)
- ④ Characteristics/Applications

Code *1	Characteristics/Applications	Series
AG	for General Use	BLM02/03/15/18/21, BLA2A/31
AX		BLM15
TG		BLM18
BA	for High-speed Signal Lines	BLM15/18
BB		BLM03/15/18/21, BLA2A
BD		BLM03/15/18/21, BLA2A/31
PD	for Power Supplies	BLM15
PG		BLM03/15/18/21/31/41
KG	for Power Supplies (Low DC Resistance Type)	BLM18
SG		BLM18
RK	for Digital Interface	BLM18/21
HG	for GHz Band General Use	BLM15/18
EG	for GHz Band General Use (Low DC Resistance Type)	
HB	for GHz Band High-speed Signal Lines	
HD		
HE		BLM18
HK	for GHz Band Digital Interface	BLM18
GA	for High-GHz Band High-speed Signal Lines	BLM15
GG	for High-GHz Band General Use	BLM15/18

*1 Frequency characteristics vary with each code.

⑤ Impedance

Expressed by three figures. The unit is in ohm (Ω). The first and second figures are significant digits, and the third figure expresses the number of zeros which follow the two figures.

⑥ Performance

Expressed by a letter.

Ex.)

Code	Performance
S/T	Sn Plating
A	Au Plating

- ⑦ Category
- ⑧ Number of Circuits
- ⑨ Packaging

EMIFIL® Capacitor Type/Capacitor Array Type

(Part Number) **NF M 3D CC 102 R 1H 3 L**
① ② ③ ④ ⑤ ⑥ ⑦ ⑧ ⑨

- ① Product ID
- ② Structure
- ③ Dimensions (L×W)

④ Features

Code	Features
CC	Capacitor Type for Signal Lines
PC	Capacitor Type for Large Current
PS	High Loss Type for Large Current

⑤ Capacitance

Expressed by three figures. The unit is in pico-farad (pF). The first and second figures are significant digits, and the third figure expresses the number of zeros which follow the two figures.

⑥ Characteristics

Code	Capacitance Change (Temperature Characteristics)
B	±10%, ±12.5%, +10/-13%
F	+30/-80%, +30/-84%
R	±15%, +15/-18%
U	-750 ±120ppm/°C
S	+350 to -1000ppm/°C

⑦ Rated Voltage

⑧ Electrode/Others (NFM Series)

Code	Electrode	Series
3	Sn Plating	NFM (Except NFM55)
4	Solder Coating	NFM55

⑧ Number of Circuits (NFA□□CC Series)

Code	Number of Circuits
4	4 Circuits

⑨ Packaging

EMIFIL® LC Combined Type

(Part Number) **NF L 18 ST 107 X 1C 3 L**
① ② ③ ④ ⑤ ⑥ ⑦ ⑧ ⑨

- ① Product ID
- ② Structure
- ③ Dimensions (L×W)
- ④ Features

Code	Features
SP	π Circuit for Signal Lines
ST	T Circuit for Signal Lines
PT	T Circuit for Large Current

⑤ Cut-off Frequency (NFL/NFW Series)

Expressed by three figures. The unit is in hertz (Hz). The first and second figures are significant digits, and the third figure expresses the number of zeros which follow the two figures.

⑥ Capacitance (NFE Series)

Expressed by three figures. The unit is in pico-farad (pF). The first and second figures are significant digits, and the third figure expresses the number of zeros which follow the two figures.



⑥ Characteristics (NFL/NFW Series)

Code	Characteristics
X	Cut-off Frequency

⑥ Characteristics (NFE Series)

Code	Capacitance Change (Temperature Characteristics)
B	±10%
C	±20%, ±22%
D	+20/-30%, +22/-33%
E	+20/-55%, +22/-56%
F	+30/-80%, +22/-82%
R	±15%
U	-750 ±120ppm/ °C
Z	Other

⑦ Rated Voltage
⑧ Electrode

Code	Electrode	Series
3/7	Sn Plating	NFL
4	Lead Free Solder Coating	NFW
9	Others	NFE

⑨ Packaging
EMIFIL® LC Combined Array Type (NFA18S/21S Series)

(Part Number) **NF** **A** **21** **SL** **207** **X** **1A** **4** **5** **L**
 ① ② ③ ④ ⑤ ⑥ ⑦ ⑧ ⑨ ⑩

- ① Product ID
- ② Structure
- ③ Dimensions (L×W)
- ④ Features

Code	Features
SL	L Circuit for Signal Lines
SD	L Circuit for Differential Signal

⑤ Cut-off Frequency

Expressed by three figures. The unit is in hertz (Hz). The first and second figures are significant digits, and the third figure expresses the number of zeros which follow the two figures.

- ⑥ Features
- ⑦ Rated Voltage
- ⑧ Number of Circuits
- ⑨ Dimensions (T)
- ⑩ Packaging

EMIFIL® RC Combined Type/RC Combined Array Type

(Part Number) **NF** **R** **21** **GD** **470** **470** **2** **L**
 ① ② ③ ④ ⑤ ⑥ ⑦ ⑧

- ① Product ID
- ② Structure
- ③ Dimensions (L×W)

④ Features

Code	Features
GD	RC Combined Type for Signal Lines

⑤ Capacitance

Expressed by three figures. The unit is in pico-farad (pF). The first and second figures are significant digits, and the third figure expresses the number of zeros which follow the two figures.

⑥ Resistance

Expressed by three-digit alphanumerics. The unit is in ohm (Ω). The first and second figures are significant digits, and the third figure expresses the number of zeros which follow the two figures. If there is a decimal point, it is expressed by the capital letter "R". In this case, all figures are significant digits.

⑦ Electrode/Others (NFR Series)

Code	Electrode
2	Sn Plating

⑦ Number of Circuits (NFA□□GD Series)

Code	Number of Circuits
4	4 Circuits

⑧ Packaging
Common Mode Choke Coil

(Part Number) **DL** **W** **21** **S** **N** **371** **S** **Q** **2** **L**
 ① ② ③ ④ ⑤ ⑥ ⑦ ⑧ ⑨ ⑩

- ① Product ID
- ② Structure
- ③ Dimensions (L×W)
- ④ Type

Code	Type
S	Magnetically Shielded One Circuit Type
D	Magnetically Shielded Two Circuit Type
H	Open Magnetic One Circuit Type
G	Magnetically Monolithic Type (sectional winding)
T	Magnetically Shielded One Circuit Low Profile Type

- ⑤ Category
 - ⑥ Impedance
 - ⑦ Circuit
 - ⑧ Features
 - ⑨ Number of Signal Lines
 - ⑩ Packaging
- Typical impedance at 100MHz is expressed by three figures. The unit is in ohm (Ω). The first and second figures are significant digits, and the third figure expresses the number of zeros which follow the two figures.

△Note • This PDF catalog is downloaded from the website of Murata Manufacturing co., Ltd. Therefore, it's specifications are subject to change or our products in it may be discontinued without advance notice. Please check with our sales representatives or product engineers before ordering.
 • This PDF catalog has only typical specifications because there is no space for detailed specifications. Therefore, please approve our product specifications or transact the approval sheet for product specifications before ordering.

Ferrite Bead Inductors

(Part Number) **BL 02 RN 2 R1 M 2 B**
① ② ③ ④ ⑤ ⑥ ⑦ ⑧

① Product ID

② Series

Code	Series
01	Beads ø3.6
02	Beads ø3.4
03	Beads ø2.3 max.

③ Beads Core Material

④ Numbers of Beads Core

⑤ Lead Type

Code	Lead Type	Series
A1	Axial Straight Type	BL01
A2	Axial Crimp Type	BL01
R1	Radial Straight Type	BL02/BL03
R2	Radial Straight and Wave Formed Leads Type	BL02
R3	Radial Incrimp Type	BL02

⑥ Lead Length, Space

Code	Lead Length, Space	Series
A	Bulk, Axial Type, 3.7mm	BL01
D	Bulk, Axial Type, 45.0mm	
E	Taping Axial Type, 26.0mm	
F	Taping, Axial Type, 52.0mm	
J	Bulk, Radial Type, 5.0mm	
M	Bulk, Radial Type, 10.0mm	BL02/BL03
N	Taping, Radial Type, 16.5mm	
P	Taping, Radial Type, 18.5mm	
Q	Taping, Radial Type, 20.0mm	

⑦ Lead Diameter

Code	Lead Diameter
1	ø0.60mm
2	ø0.65mm

⑧ Packaging

Disc Type EMIFIL®

(Part Number) **DS S 9 H B3 2E 271 Q55 B**
① ② ③ ④ ⑤ ⑥ ⑦ ⑧ ⑨

① Product ID

② Structure

③ Style

Code	Style
6	Diameter 8.0mm max.
9	Diameter 12.0mm max.



④ Category

Code	Category
N	for General Use
H	for Heavy-duty

⑤ Temperature Characteristics

Code	Capacitance Change
B3/P3	±10% (Temperature Range: -25°C to +85°C)
C5	±22% (Temperature Range: -25°C to +85°C)
T3	+20/-30% (Temperature Range: -25°C to +85°C)
E5	+22/-56% (Temperature Range: -25°C to +85°C)
F3	+30/-80% (Temperature Range: -25°C to +85°C)
Z8	+30/-85% (Temperature Range: -10°C to +60°C)

⑥ Rated Voltage

⑦ Capacitance

Expressed by three figures. The unit is in pico-farad (pF). The first and second figures are significant digits, and the third figure expresses the number of zeros which follow the two figures.

⑧ Lead Type / ⑨ Packaging

Code	Lead Type	Lead Length* (in mm)	Packaging	Series
Q55B	Straight	25.0 min.	Bulk	All series
Q50B		4.0±0.5		DST9N/H
Q52B		6.0±1.0		DST9N
Q54B		4.0±0.5		DSN6N/9N, DSS6N/9N, DSS9H
Q56B		6.0±1.0		DSS6N
T41B	Incrimp	4.0±0.5	Paper Reel (ø320mm)	DSS9N/H
T51B		25.0 min.		
Q91J	Straight	20.0±1.0	Ammo Pack	DS□6, DSN9N/H
Q92J		16.5±1.0		
Q93J		18.5±1.0		
Q91A		20.0±1.0		
Q92A		16.5±1.0		
Q93A	18.5±1.0	DSS6N		
U21A	16.5±1.0			
U31A	Incrimp	18.5±1.0		

*Lead Distance between Reference and Bottom Planes except Bulk.

Leaded Common Mode Choke Coil

(Part Number) **PL T 09H N 200 3R0 P 1 B**
① ② ③ ④ ⑤ ⑥ ⑦ ⑧ ⑨

① Product ID

② Type

③ Applications

④ Features

⑤ Inductance

Expressed by three figures. The unit is micro-henry (µH). The first and second figures are significant digits, and the third figure expresses the number of zeros which follow the two figures.

⑥ Rated Current

Expressed by three-digit alphanumerics. The unit is in amperes (A). A decimal point is expressed by the capital letter "R". In this case, all figures are significant digits.



7 Winding Mode

Code	Winding Mode
P	Aligned Winding Type

8 Lead Dimensions

9 Packaging

Lead Type EMIGUARD® (EMIFIL® with Varistor Function)

(Part Number) **VF** **S** **6** **V** **D8** **1E** **221** **T51** **B**

1
2
3
4
5
6
7
8
9

1 Product ID

2 Structure

Code	Structure
S	Built-in Ferrite Beads Type
R	with Resistance

3 Style

4 Features

5 Temperature Characteristics

Code	Capacitance Change
D8	+20/-30% (Temperature Range: -40°C to +105°C)
D3	+20/-30% (Temperature Range: -25°C to +85°C)

6 Rated Voltage

7 Capacitance

Expressed by three figures. The unit is in pico-farad (pF). The first and second figures are significant digits, and the third figure expresses the number of zeros which follow the two figures.

8 Lead Type / **9** Packaging

Code	Lead Type	Lead Length*	Packaging	Series
T51B	Incrimp	25.0mm min.	Bulk	VFR3/VFS6
U31A		18.5+/-1.0mm	Ammo Pack	
Q55B	Straight	25.0mm min.	Bulk	VFS9
Q91J		20.0+/-1.0mm	Paper Reel (ø320mm)	
Q92J		16.5+/-1.0mm		
Q93J		18.5+/-1.0mm		

*Lead Distance between Reference and Bottom Planes except Bulk.

AC Line Filters

(Part Number) **PL** **A** **10** **A** **S** **152** **2R0** **R** **2** **B**

1
2
3
4
5
6
7
8
9
10

1 Product ID

2 Type

3 Applications

4 Structure

Code	Structure
A	Core Vertical Type
B	Core Horizontal Type

5 Features

6 Inductance

Expressed by three figures. The unit is micro-henry (μH). The first and second figures are significant digits, and the third figure expresses the number of zeros which follow the two figures.

7 Rated Current

Expressed by three-digit alphanumerics. The unit is in amperes (A). A decimal point is expressed by the capital letter "R". In this case, all figures are significant digits.

8 Winding Mode

Code	Winding Mode
A	Parallel Winding Type
B	Parallel Winding Type (High Performance Type)
D	Sectional Winding Type
R	Standard Type
P	Single Layer Winding Type

9 Lead Dimensions

10 Packaging

Microwave Absorber

(Part Number) **EA** **1026** **A** **160** **M** **200** **200**

1
2
3
4
5
6
7

1 Product ID

2 Sheet Type

Code	Sheet Type
10□□	Iron carbonyl type (UL certified type/non Halogen type)
2070	Metal Flake Powder (non Halogen type)
2100	Metal Flake Powder (UL certified type)
2200	Metal Flake Powder (UL certified type/non Halogen type)
3008	Magnetic material (UL certified type/non Halogen type)

3 Adhesive Tape Type

Code	Adhesive Tape Type
A	Standard tape type (non Halogen type)
B	Thin Adhesive tape type (non Halogen type)
L	No tape type
U	UL certified type (non Halogen type)

4 Sheet Thickness

5 Unit of Dimension

One capital letter expresses Unit of Dimension (**6**) and Dimensions Length (**7**).

Code	Unit of Dimension
M	in mm (Standard)
C	in cm (Standard)

Standard shape is a rectangle.

Please contact us for other shapes.

6 Dimension (Length)

Expressed by three digits including the first decimal place.



⑦ Dimension (Width)

Expressed by three digits including the first decimal place.

Ex.)

Code	Dimension (Length × Width)
M300150	30.0×15.0 mm
C150100	15.0×10.0 cm

Ferrite Core

(Part Number) **FS RB 12 1 060 RT B0 0 T**
① ② ③ ④ ⑤ ⑥ ⑦ ⑧ ⑨

- ① Product ID
- ② Series
- ③ Dimensions
- ④ Outer Dimension Supplement Code
- ⑤ Length
- ⑥ Material
- ⑦ Process
- ⑧ Individual Specification Code
- ⑨ Packaging

EMIFIL® (Inductor Type)

Chip Ferrite Bead

Equivalent Circuit

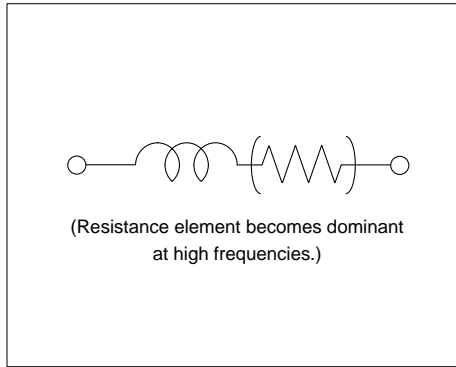

● BLM_A Series

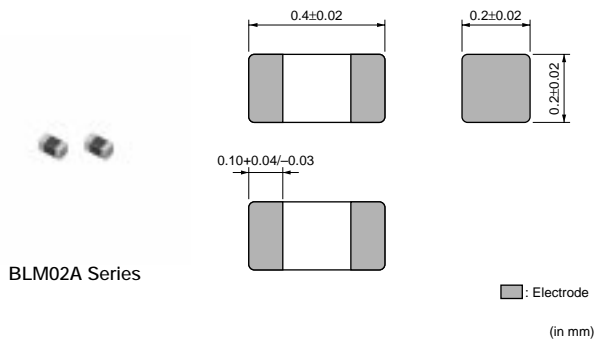

Impedance-Frequency Characteristics (Main Items)

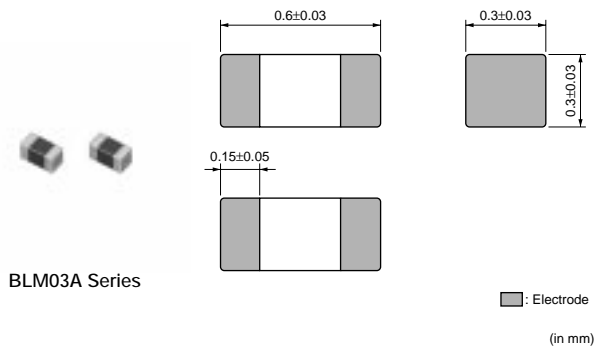
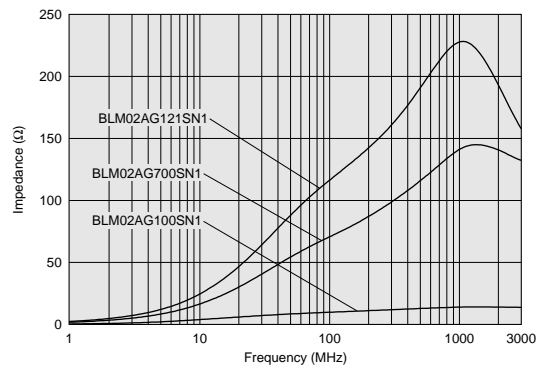

Impedance-Frequency Characteristics (Main Items)

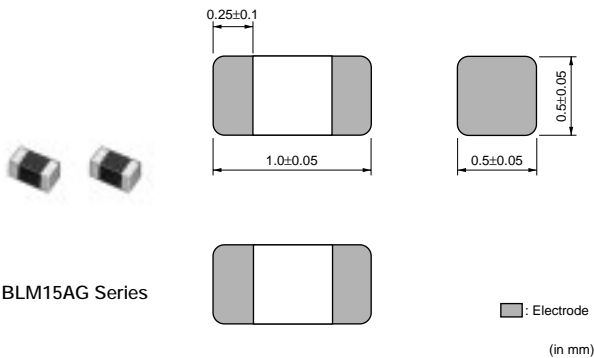
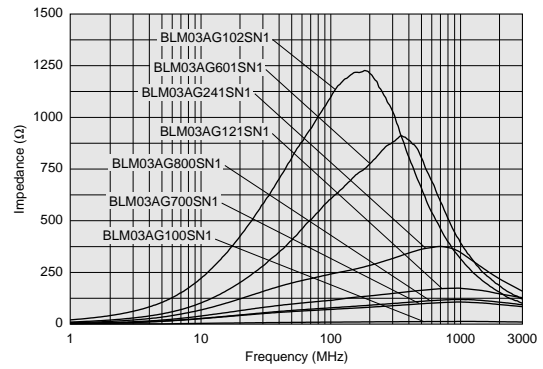

Impedance-Frequency Characteristics (Main Items)

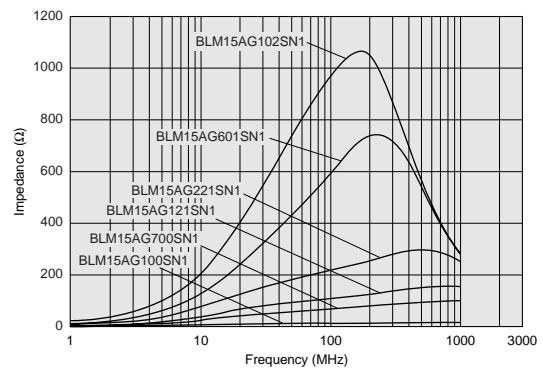

Continued on the following page.

△Note • This PDF catalog is downloaded from the website of Murata Manufacturing co., ltd. Therefore, it's specifications are subject to change or our products in it may be discontinued without advance notice. Please check with our sales representatives or product engineers before ordering.
• This PDF catalog has only typical specifications because there is no space for detailed specifications. Therefore, please approve our product specifications or transact the approval sheet for product specifications before ordering.

Continued from the preceding page.

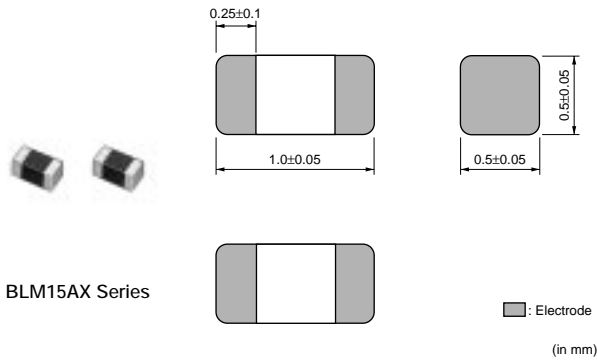

Impedance-Frequency Characteristics (Main Items)

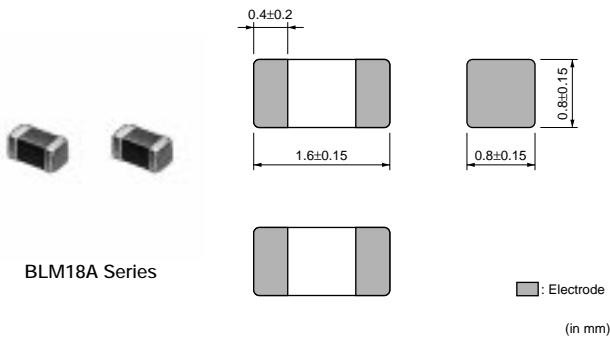
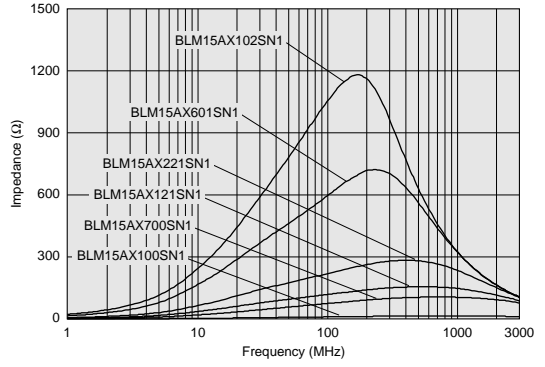

Impedance-Frequency Characteristics (Main Items)

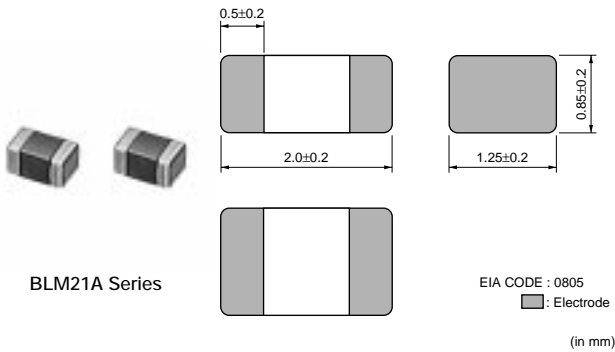
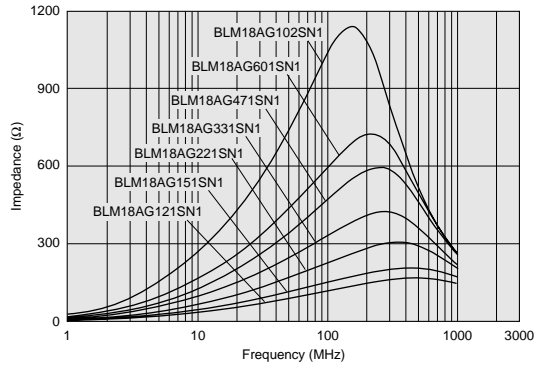

Impedance-Frequency Characteristics (Main Items)

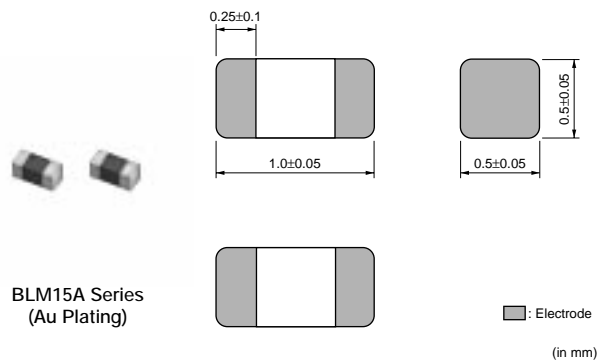
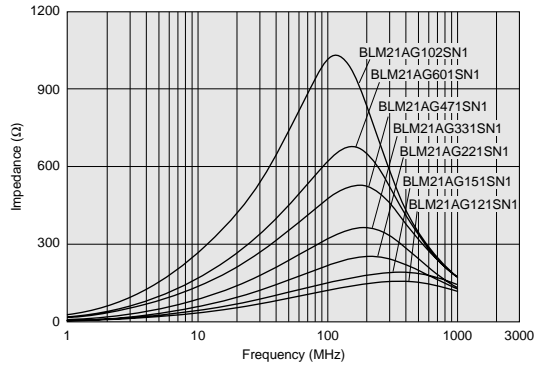

Impedance-Frequency Characteristics (Main Items)

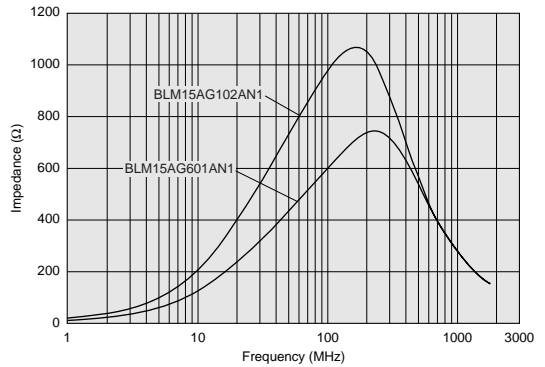

Note • This PDF catalog is downloaded from the website of Murata Manufacturing co., Ltd. Therefore, its specifications are subject to change or our products in it may be discontinued without advance notice. Please check with our sales representatives or product engineers before ordering.
• This PDF catalog has only typical specifications because there is no space for detailed specifications. Therefore, please approve our product specifications or transact the approval sheet for product specifications before ordering.

Part Number	Impedance (at 100MHz/20°C) (ohm)	Rated Current (mA)	DC Resistance (max.) (ohm)	Operating Temperature Range	Case Size
BLM02AG100SN1	10 (Typ.)	500	0.1	-55 to +125°C	01005
BLM02AG700SN1	70 ±25%	250	0.5	-55 to +125°C	01005
BLM02AG121SN1	120 ±25%	200	0.8	-55 to +125°C	01005
BLM03AG100SN1	10 (Typ.)	500	0.1	-55 to +125°C	0201
BLM03AG700SN1	70 (Typ.)	200	0.4	-55 to +125°C	0201
BLM03AG800SN1	80 ±25%	200	0.4	-55 to +125°C	0201
BLM03AG121SN1	120 ±25%	200	0.5	-55 to +125°C	0201
BLM03AG241SN1	240 ±25%	200	0.8	-55 to +125°C	0201
BLM03AG601SN1	600 ±25%	100	1.5	-55 to +125°C	0201
BLM03AG102SN1	1000 ±25%	100	2.5	-55 to +125°C	0201
BLM15AG100SN1	10 (Typ.)	1000	0.05	-55 to +125°C	0402
BLM15AX100SN1	10 (Typ.)	1740	0.02	-55 to +125°C	0402
BLM15AG700SN1	70 (Typ.)	500	0.15	-55 to +125°C	0402
BLM15AX700SN1	70 ±25%	780	0.1	-55 to +125°C	0402
BLM15AG121SN1	120 ±25%	500	0.25	-55 to +125°C	0402
BLM15AX121SN1	120 ±25%	680	0.13	-55 to +125°C	0402
BLM15AG221SN1	220 ±25%	300	0.35	-55 to +125°C	0402
BLM15AX221SN1	220 ±25%	580	0.18	-55 to +125°C	0402
BLM15AG601SN1	600 ±25%	300	0.6	-55 to +125°C	0402
BLM15AX601SN1	600 ±25%	420	0.34	-55 to +125°C	0402
BLM15AG102SN1	1000 ±25%	200	1.0	-55 to +125°C	0402
BLM15AX102SN1	1000 ±25%	350	0.49	-55 to +125°C	0402
BLM18AG121SN1	120 ±25%	500	0.18	-55 to +125°C	0603
BLM18AG151SN1	150 ±25%	500	0.25	-55 to +125°C	0603
BLM18AG221SN1	220 ±25%	500	0.25	-55 to +125°C	0603
BLM18AG331SN1	330 ±25%	500	0.30	-55 to +125°C	0603
BLM18AG471SN1	470 ±25%	500	0.35	-55 to +125°C	0603
BLM18AG601SN1	600 ±25%	500	0.38	-55 to +125°C	0603
BLM18AG102SN1	1000 ±25%	400	0.50	-55 to +125°C	0603
BLM21AG121SN1	120 ±25%	200	0.15	-55 to +125°C	0805
BLM21AG151SN1	150 ±25%	200	0.15	-55 to +125°C	0805
BLM21AG221SN1	220 ±25%	200	0.20	-55 to +125°C	0805
BLM21AG331SN1	330 ±25%	200	0.25	-55 to +125°C	0805
BLM21AG471SN1	470 ±25%	200	0.25	-55 to +125°C	0805
BLM21AG601SN1	600 ±25%	200	0.30	-55 to +125°C	0805
BLM21AG102SN1	1000 ±25%	200	0.45	-55 to +125°C	0805
BLM15AG601AN1	600 ±25%	300	0.6	-55 to +125°C	0402
BLM15AG102AN1	1000 ±25%	200	1.0	-55 to +125°C	0402

● BLM_B Series

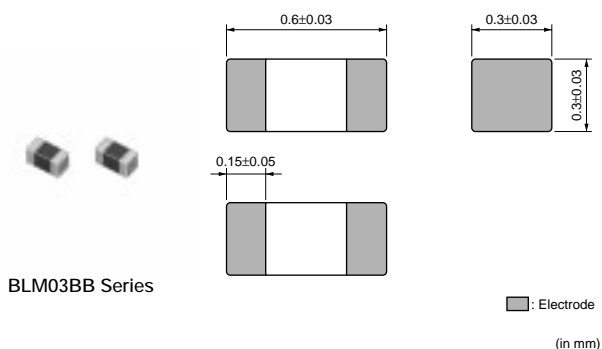

BLM03BB Series

Impedance-Frequency Characteristics (Main Items)

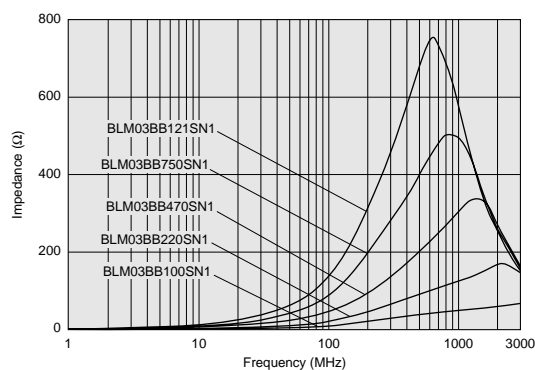

Continued on the following page.

△Note • This PDF catalog is downloaded from the website of Murata Manufacturing co., ltd. Therefore, it's specifications are subject to change or our products in it may be discontinued without advance notice. Please check with our sales representatives or product engineers before ordering.
 • This PDF catalog has only typical specifications because there is no space for detailed specifications. Therefore, please approve our product specifications or transact the approval sheet for product specifications before ordering.

Continued from the preceding page.

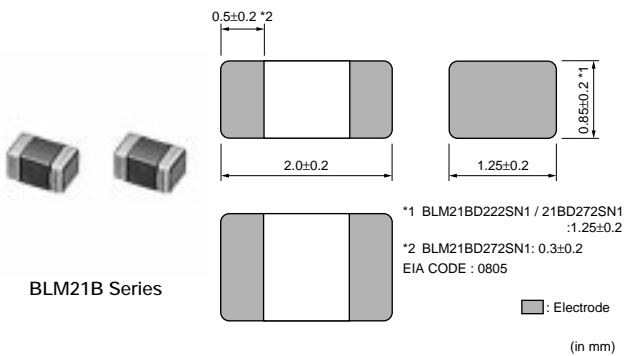
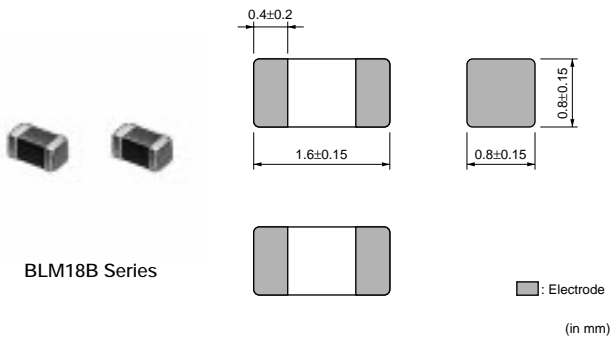
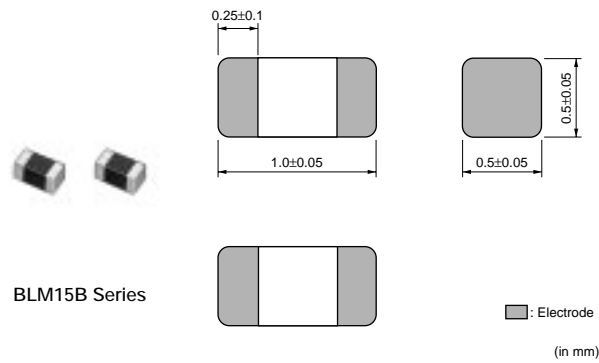
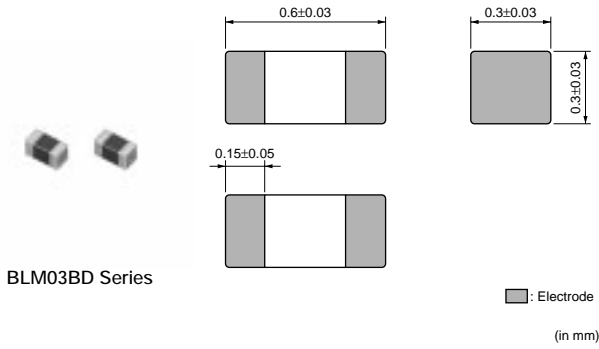

Impedance-Frequency Characteristics (Main Items)

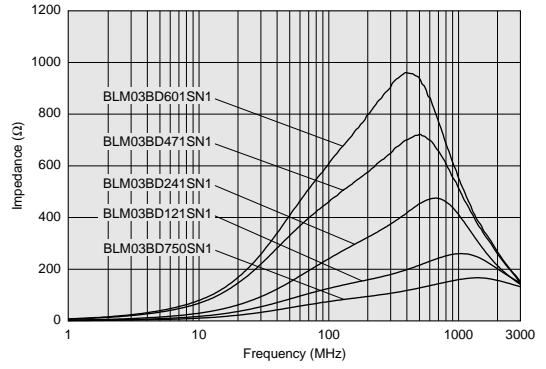

Impedance-Frequency Characteristics (Main Items)

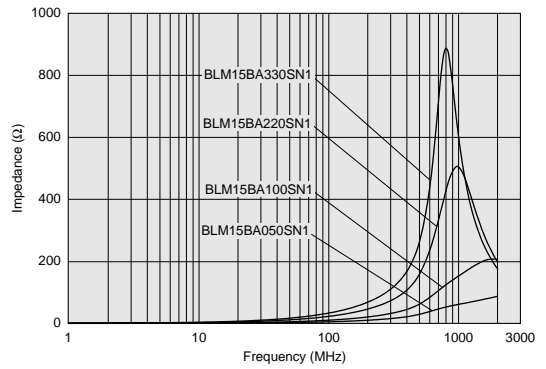

Impedance-Frequency Characteristics (Main Items)

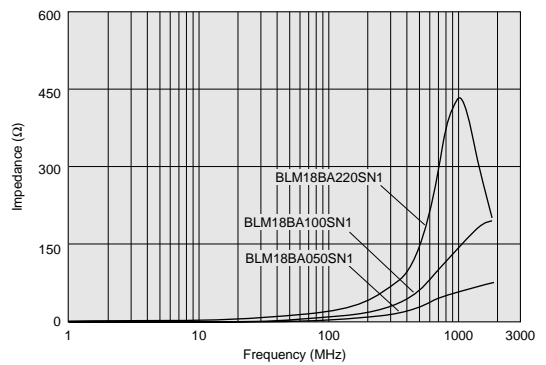

Impedance-Frequency Characteristics (Main Items)

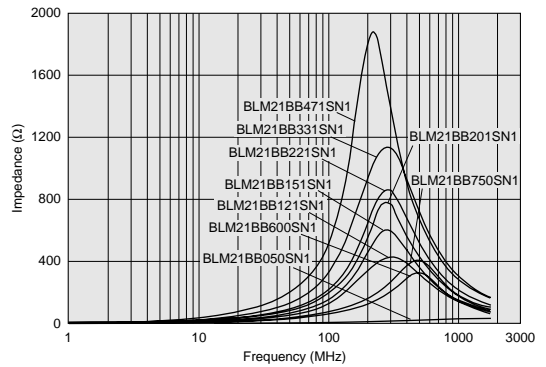

Part Number	Impedance (at 100MHz/20°C) (ohm)	Rated Current (mA)	DC Resistance (max.) (ohm)	Operating Temperature Range	Case Size
BLM03BB100SN1	10 ±25%	300	0.4	-55 to +125°C	0201
BLM03BB220SN1	22 ±25%	200	0.5	-55 to +125°C	0201
BLM03BB470SN1	47 ±25%	200	0.7	-55 to +125°C	0201
BLM03BB750SN1	75 ±25%	200	1.0	-55 to +125°C	0201
BLM03BD750SN1	75 ±25%	300	0.4	-55 to +125°C	0201
BLM03BB121SN1	120 ±25%	100	1.5	-55 to +125°C	0201
BLM03BD121SN1	120 ±25%	250	0.5	-55 to +125°C	0201
BLM03BD241SN1	240 ±25%	200	0.8	-55 to +125°C	0201
BLM03BD471SN1	470 ±25%	215	1.5	-55 to +125°C	0201
BLM03BD601SN1	600 ±25%	200	1.7	-55 to +125°C	0201
BLM15BA050SN1	5 ±25%	300	0.10	-55 to +125°C	0402
BLM15BB050SN1	5 ±25%	500	0.08	-55 to +125°C	0402
BLM15BA100SN1	10 ±25%	300	0.20	-55 to +125°C	0402
BLM15BB100SN1	10 ±25%	300	0.10	-55 to +125°C	0402
BLM15BA220SN1	22 ±25%	300	0.30	-55 to +125°C	0402
BLM15BB220SN1	22 ±25%	300	0.20	-55 to +125°C	0402
BLM15BA330SN1	33 ±25%	300	0.40	-55 to +125°C	0402
BLM15BA470SN1	47 ±25%	200	0.60	-55 to +125°C	0402
BLM15BB470SN1	47 ±25%	300	0.35	-55 to +125°C	0402
BLM15BA750SN1	75 ±25%	200	0.80	-55 to +125°C	0402
BLM15BB750SN1	75 ±25%	300	0.40	-55 to +125°C	0402
BLM15BD750SN1	75 ±25%	300	0.20	-55 to +125°C	0402
BLM15BB121SN1	120 ±25%	300	0.55	-55 to +125°C	0402
BLM15BD121SN1	120 ±25%	300	0.30	-55 to +125°C	0402
BLM15BB221SN1	220 ±25%	200	0.80	-55 to +125°C	0402
BLM15BD221SN1	220 ±25%	300	0.40	-55 to +125°C	0402
BLM15BD471SN1	470 ±25%	200	0.60	-55 to +125°C	0402
BLM15BD601SN1	600 ±25%	200	0.65	-55 to +125°C	0402
BLM15BD102SN1	1000 ±25%	200	0.90	-55 to +125°C	0402
BLM15BD182SN1	1800 ±25%	100	1.40	-55 to +125°C	0402
BLM18BA050SN1	5 ±25%	500	0.20	-55 to +125°C	0603
BLM18BB050SN1	5 ±25%	700	0.05	-55 to +125°C	0603
BLM18BA100SN1	10 ±25%	500	0.25	-55 to +125°C	0603
BLM18BB100SN1	10 ±25%	700	0.10	-55 to +125°C	0603
BLM18BA220SN1	22 ±25%	500	0.35	-55 to +125°C	0603
BLM18BB220SN1	22 ±25%	600	0.20	-55 to +125°C	0603
BLM18BA470SN1	47 ±25%	300	0.55	-55 to +125°C	0603
BLM18BB470SN1	47 ±25%	550	0.25	-55 to +125°C	0603
BLM18BD470SN1	47 ±25%	500	0.30	-55 to +125°C	0603
BLM18BB600SN1	60 ±25%	550	0.25	-55 to +125°C	0603
BLM18BA750SN1	75 ±25%	300	0.70	-55 to +125°C	0603
BLM18BB750SN1	75 ±25%	500	0.30	-55 to +125°C	0603
BLM18BA121SN1	120 ±25%	200	0.90	-55 to +125°C	0603
BLM18BB121SN1	120 ±25%	500	0.30	-55 to +125°C	0603
BLM18BD121SN1	120 ±25%	200	0.40	-55 to +125°C	0603
BLM18BB141SN1	140 ±25%	450	0.35	-55 to +125°C	0603
BLM18BB151SN1	150 ±25%	450	0.37	-55 to +125°C	0603
BLM18BD151SN1	150 ±25%	200	0.40	-55 to +125°C	0603
BLM18BB221SN1	220 ±25%	450	0.45	-55 to +125°C	0603
BLM18BD221SN1	220 ±25%	200	0.45	-55 to +125°C	0603
BLM18BB331SN1	330 ±25%	400	0.58	-55 to +125°C	0603
BLM18BD331SN1	330 ±25%	200	0.50	-55 to +125°C	0603
BLM18BD421SN1	420 ±25%	200	0.55	-55 to +125°C	0603
BLM18BB471SN1	470 ±25%	300	0.85	-55 to +125°C	0603
BLM18BD471SN1	470 ±25%	200	0.55	-55 to +125°C	0603

Continued on the following page. 

△Note • This PDF catalog is downloaded from the website of Murata Manufacturing co., Ltd. Therefore, it's specifications are subject to change or our products in it may be discontinued without advance notice. Please check with our sales representatives or product engineers before ordering.
• This PDF catalog has only typical specifications because there is no space for detailed specifications. Therefore, please approve our product specifications or transact the approval sheet for product specifications before ordering.

Continued from the preceding page.

Part Number	Impedance (at 100MHz/20°C) (ohm)	Rated Current (mA)	DC Resistance (max.) (ohm)	Operating Temperature Range	Case Size
BLM18BD601SN1	600 ±25%	200	0.65	-55 to +125°C	0603
BLM18BD102SN1	1000 ±25%	100	0.85	-55 to +125°C	0603
BLM18BD152SN1	1500 ±25%	50	1.20	-55 to +125°C	0603
BLM18BD182SN1	1800 ±25%	50	1.50	-55 to +125°C	0603
BLM18BD222SN1	2200 ±25%	50	1.50	-55 to +125°C	0603
BLM18BD252SN1	2500 ±25%	50	1.50	-55 to +125°C	0603
BLM21BB050SN1	5 ±25%	500	0.07	-55 to +125°C	0805
BLM21BB600SN1	60 ±25%	200	0.20	-55 to +125°C	0805
BLM21BB750SN1	75 ±25%	200	0.25	-55 to +125°C	0805
BLM21BB121SN1	120 ±25%	200	0.25	-55 to +125°C	0805
BLM21BD121SN1	120 ±25%	200	0.25	-55 to +125°C	0805
BLM21BB151SN1	150 ±25%	200	0.25	-55 to +125°C	0805
BLM21BD151SN1	150 ±25%	200	0.25	-55 to +125°C	0805
BLM21BB201SN1	200 ±25%	200	0.35	-55 to +125°C	0805
BLM21BB221SN1	220 ±25%	200	0.35	-55 to +125°C	0805
BLM21BD221SN1	220 ±25%	200	0.25	-55 to +125°C	0805
BLM21BB331SN1	330 ±25%	200	0.40	-55 to +125°C	0805
BLM21BD331SN1	330 ±25%	200	0.30	-55 to +125°C	0805
BLM21BD421SN1	420 ±25%	200	0.30	-55 to +125°C	0805
BLM21BB471SN1	470 ±25%	200	0.45	-55 to +125°C	0805
BLM21BD471SN1	470 ±25%	200	0.35	-55 to +125°C	0805
BLM21BD601SN1	600 ±25%	200	0.35	-55 to +125°C	0805
BLM21BD751SN1	750 ±25%	200	0.40	-55 to +125°C	0805
BLM21BD102SN1	1000 ±25%	200	0.40	-55 to +125°C	0805
BLM21BD152SN1	1500 ±25%	200	0.45	-55 to +125°C	0805
BLM21BD182SN1	1800 ±25%	200	0.50	-55 to +125°C	0805
BLM21BD222TN1	2200 ±25%	200	0.60	-55 to +125°C	0805
BLM21BD222SN1	2250 (Typ.)	200	0.60	-55 to +125°C	0805
BLM21BD272SN1	2700 ±25%	200	0.80	-55 to +125°C	0805

● BLM18T Series

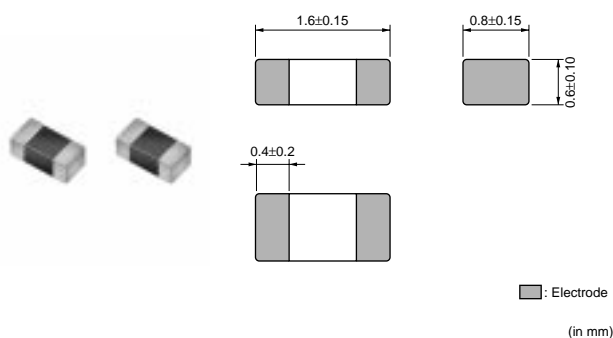

Impedance-Frequency Characteristics (Main Items)

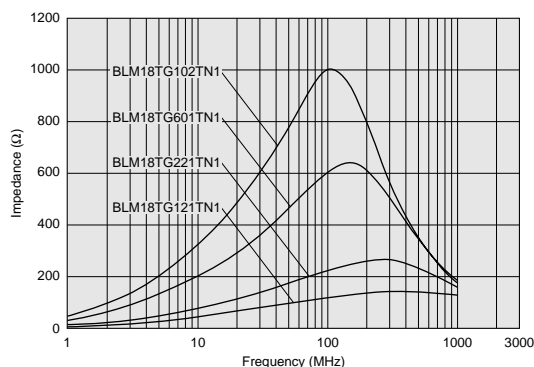

Part Number	Impedance (at 100MHz/20°C) (ohm)	Rated Current (mA)	DC Resistance (max.) (ohm)	Operating Temperature Range	Case Size
BLM18TG121TN1	120 ±25%	200	0.25	-55 to +125°C	0603
BLM18TG221TN1	220 ±25%	200	0.30	-55 to +125°C	0603
BLM18TG601TN1	600 ±25%	200	0.45	-55 to +125°C	0603
BLM18TG102TN1	1000 ±25%	100	0.60	-55 to +125°C	0603

● BLM_R Series

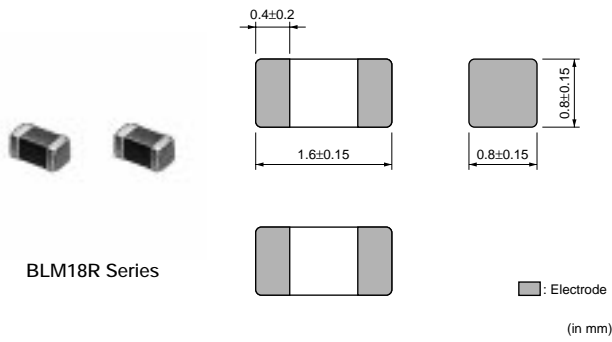

Impedance-Frequency Characteristics (Main Items)

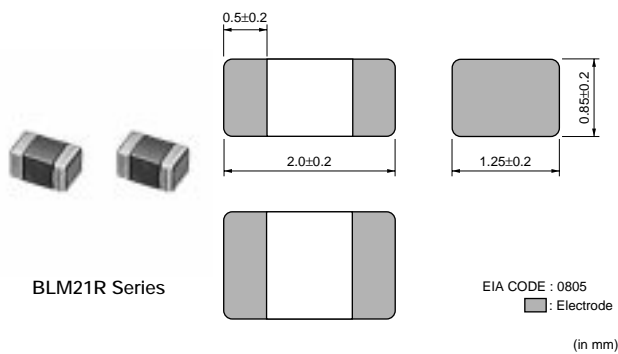
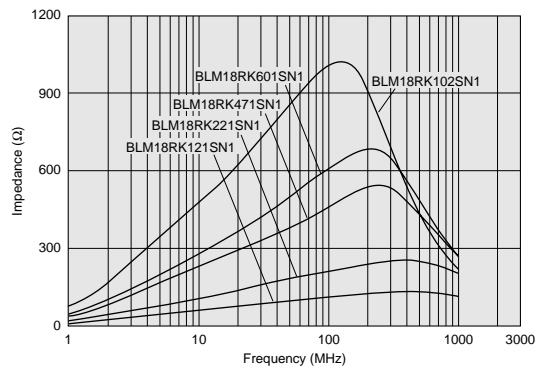

Impedance-Frequency Characteristics (Main Items)

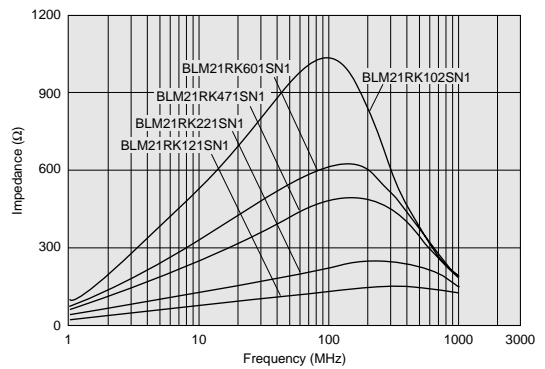

Part Number	Impedance (at 100MHz/20°C) (ohm)	Rated Current (mA)	DC Resistance (max.) (ohm)	Operating Temperature Range	Case Size
BLM18RK121SN1	120 ±25%	200	0.25	-55 to +125°C	0603
BLM18RK221SN1	220 ±25%	200	0.30	-55 to +125°C	0603
BLM18RK471SN1	470 ±25%	200	0.50	-55 to +125°C	0603
BLM18RK601SN1	600 ±25%	200	0.60	-55 to +125°C	0603
BLM18RK102SN1	1000 ±25%	200	0.80	-55 to +125°C	0603
BLM21RK121SN1	120 ±25%	200	0.15	-55 to +125°C	0805
BLM21RK221SN1	220 ±25%	200	0.20	-55 to +125°C	0805
BLM21RK471SN1	470 ±25%	200	0.25	-55 to +125°C	0805
BLM21RK601SN1	600 ±25%	200	0.30	-55 to +125°C	0805
BLM21RK102SN1	1000 ±25%	200	0.50	-55 to +125°C	0805

● BLM_P Series

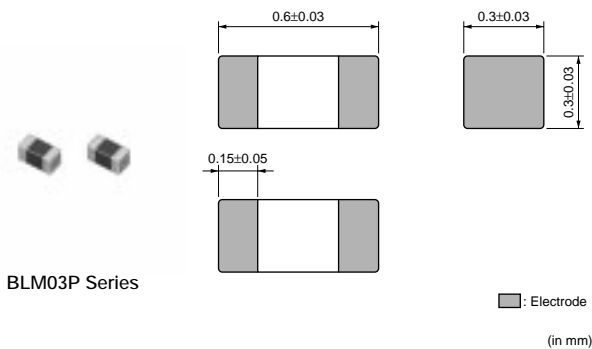

Impedance-Frequency Characteristics (Main Items)

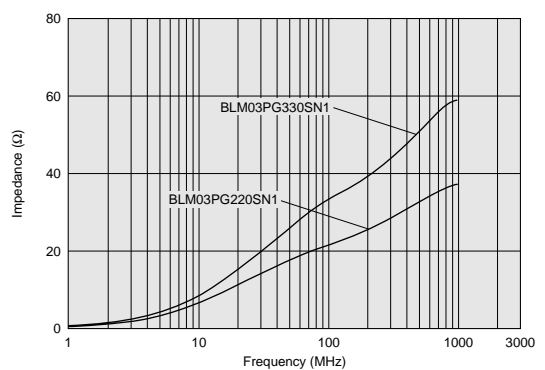

Continued on the following page.

△Note • This PDF catalog is downloaded from the website of Murata Manufacturing co., ltd. Therefore, it's specifications are subject to change or our products in it may be discontinued without advance notice. Please check with our sales representatives or product engineers before ordering.
• This PDF catalog has only typical specifications because there is no space for detailed specifications. Therefore, please approve our product specifications or transact the approval sheet for product specifications before ordering.

Continued from the preceding page.

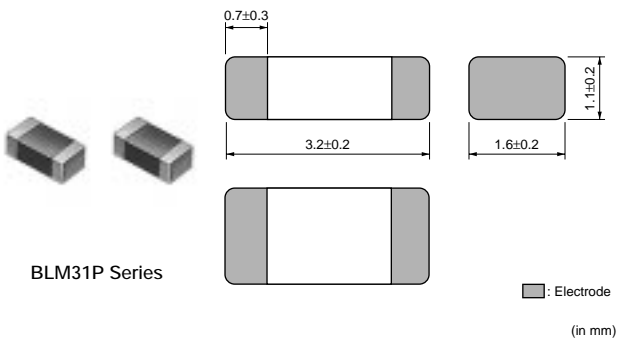
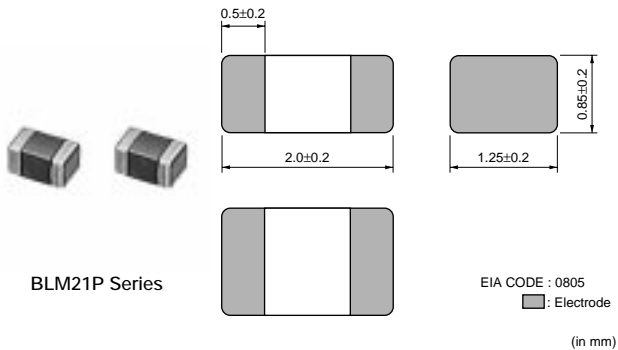
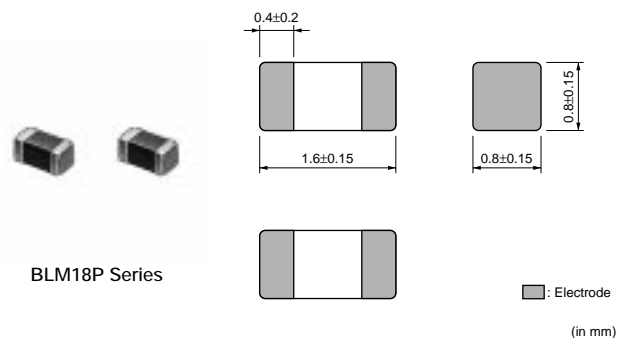
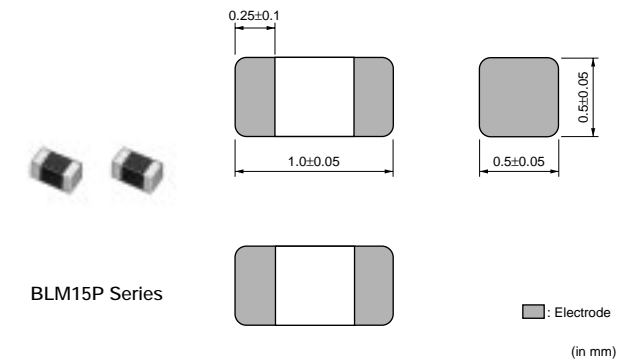

Impedance-Frequency Characteristics (Main Items)

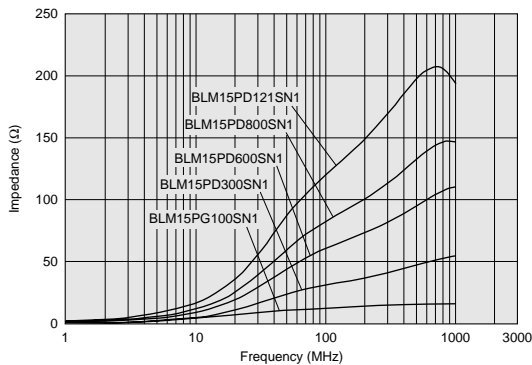

Impedance-Frequency Characteristics (Main Items)

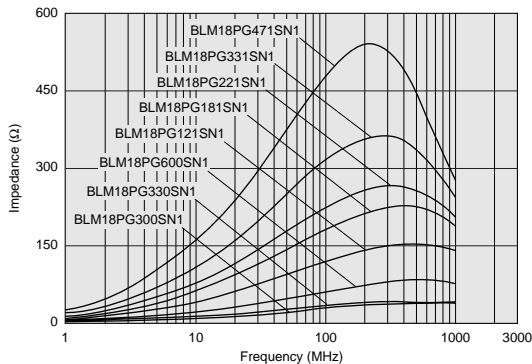

Impedance-Frequency Characteristics (Main Items)

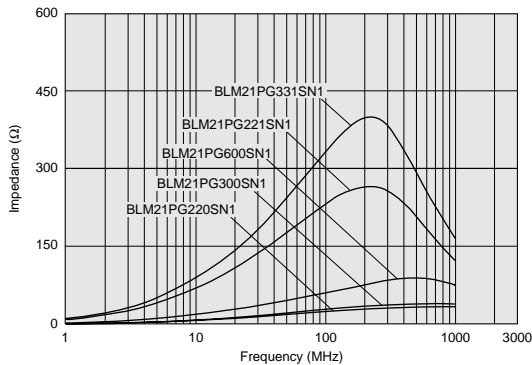

Impedance-Frequency Characteristics (Main Items)

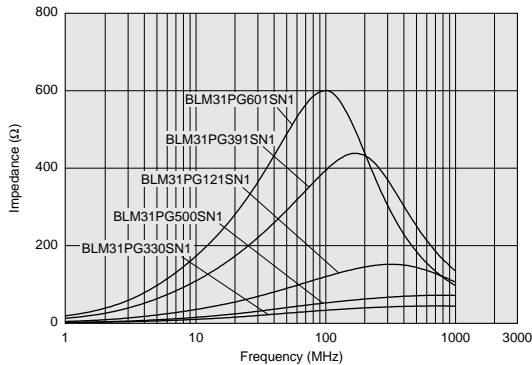

Continued on the following page.

Continued from the preceding page.

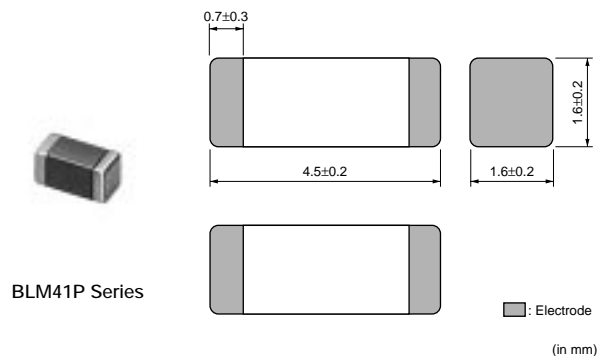

Impedance-Frequency Characteristics (Main Items)

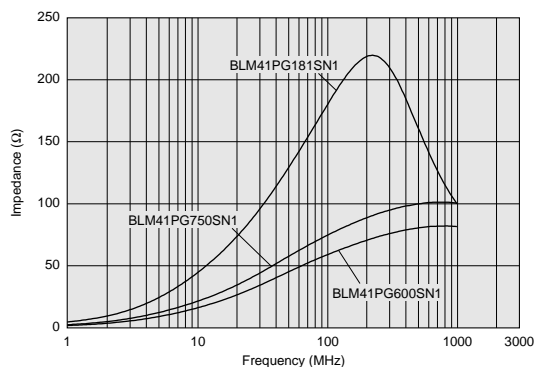

Part Number	Impedance (at 100MHz/20°C) (ohm)	Rated Current (mA)	DC Resistance (max.) (ohm)	Operating Temperature Range	Case Size
BLM03PG220SN1	22 ±25%	900	0.065	-55 to +125°C	0201
BLM03PG330SN1	33 ±25%	750	0.090	-55 to +125°C	0201
BLM15PG100SN1	10 (Typ.)	1000	0.05	-55 to +125°C	0402
BLM15PD300SN1	30 ±25%	2200	0.035	-55 to +125°C	0402
BLM15PD600SN1	60 ±25%	1700	0.06	-55 to +125°C	0402
BLM15PD800SN1	80 ±25%	1500	0.07	-55 to +125°C	0402
BLM15PD121SN1	120 ±25%	1300	0.09	-55 to +125°C	0402
BLM18PG300SN1	30 (Typ.)	1000	0.05	-55 to +125°C	0603
BLM18PG330SN1	33 ±25%	3000	0.025	-55 to +125°C	0603
BLM18PG600SN1	60 (Typ.)	500	0.10	-55 to +125°C	0603
BLM18PG121SN1	120 ±25%	2000	0.05	-55 to +125°C	0603
BLM18PG181SN1	180 ±25%	1500	0.09	-55 to +125°C	0603
BLM18PG221SN1	220 ±25%	1400	0.10	-55 to +125°C	0603
BLM18PG331SN1	330 ±25%	1200	0.15	-55 to +125°C	0603
BLM18PG471SN1	470 ±25%	1000	0.20	-55 to +125°C	0603
BLM21PG220SN1	22 ±25%	6000	0.01	-55 to +125°C	0805
BLM21PG300SN1	30 (Typ.)	3000	0.015	-55 to +125°C	0805
BLM21PG600SN1	60 ±25%	3000	0.025	-55 to +125°C	0805
BLM21PG221SN1	220 ±25%	2000	0.050	-55 to +125°C	0805
BLM21PG331SN1	330 ±25%	1500	0.09	-55 to +125°C	0805
BLM31PG330SN1	33 ±25%	6000	0.01	-55 to +125°C	1206
BLM31PG500SN1	50 (Typ.)	3000	0.025	-55 to +125°C	1206
BLM31PG121SN1	120 ±25%	3000	0.025	-55 to +125°C	1206
BLM31PG391SN1	390 ±25%	2000	0.05	-55 to +125°C	1206
BLM31PG601SN1	600 ±25%	1500	0.09	-55 to +125°C	1206
BLM41PG600SN1	60 (Typ.)	6000	0.01	-55 to +125°C	1806
BLM41PG750SN1	75 (Typ.)	3000	0.025	-55 to +125°C	1806
BLM41PG181SN1	180 ±25%	3000	0.025	-55 to +125°C	1806
BLM41PG471SN1	470 ±25%	2000	0.05	-55 to +125°C	1806
BLM41PG102SN1	1000 ±25%	1500	0.09	-55 to +125°C	1806

To operate at the temperature over +85°C, some of these items need derating of rated current. Please contact us for details.

△Note • This PDF catalog is downloaded from the website of Murata Manufacturing co., ltd. Therefore, it's specifications are subject to change or our products in it may be discontinued without advance notice. Please check with our sales representatives or product engineers before ordering.
• This PDF catalog has only typical specifications because there is no space for detailed specifications. Therefore, please approve our product specifications or transact the approval sheet for product specifications before ordering.

● BLM18K Series

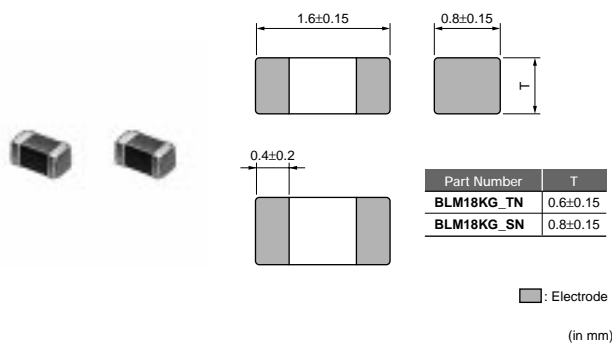

Impedance-Frequency Characteristics (Main Items)

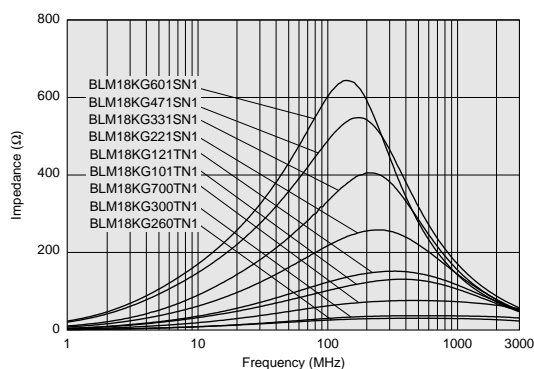

Part Number	Impedance (at 100MHz/20°C) (ohm)	Rated Current (mA)	DC Resistance (max.) (ohm)	Operating Temperature Range	Case Size
BLM18KG260TN1	26 ±25%	6000	0.007	-55 to +125°C	0603
BLM18KG300TN1	30 ±25%	5000	0.010	-55 to +125°C	0603
BLM18KG700TN1	70 ±25%	3500	0.022	-55 to +125°C	0603
BLM18KG101TN1	100 ±25%	3000	0.030	-55 to +125°C	0603
BLM18KG121TN1	120 ±25%	3000	0.030	-55 to +125°C	0603
BLM18KG221SN1	220 ±25%	2200	0.050	-55 to +125°C	0603
BLM18KG331SN1	330 ±25%	1700	0.080	-55 to +125°C	0603
BLM18KG471SN1	470 ±25%	1500	0.130	-55 to +125°C	0603
BLM18KG601SN1	600 ±25%	1300	0.150	-55 to +125°C	0603

To operate at the temperature over +85°C, some of these items need derating of rated current. Please contact us for details.

● BLM18S Series

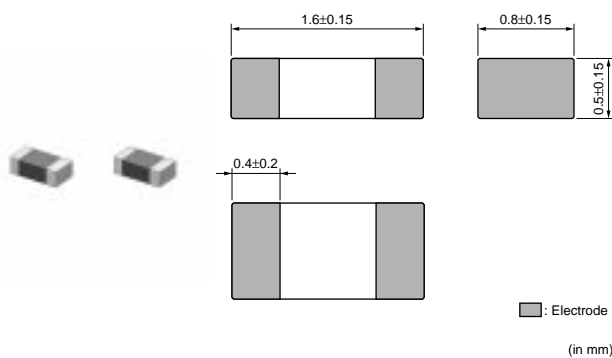

Impedance-Frequency Characteristics (Main Items)

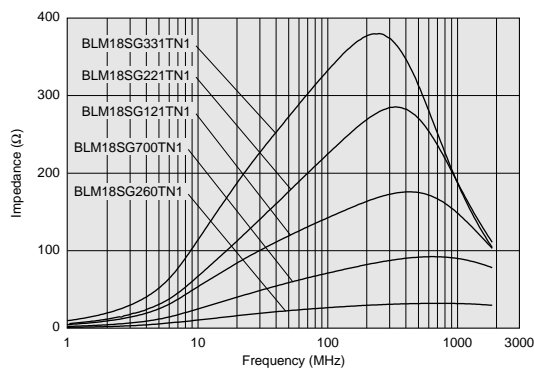

Part Number	Impedance (at 100MHz/20°C) (ohm)	Rated Current (mA)	DC Resistance (max.) (ohm)	Operating Temperature Range	Case Size
BLM18SG260TN1	26 ±25%	6000	0.007	-55 to +125°C	0603
BLM18SG700TN1	70 ±25%	4000	0.020	-55 to +125°C	0603
BLM18SG121TN1	120 ±25%	3000	0.025	-55 to +125°C	0603
BLM18SG221TN1	220 ±25%	2500	0.040	-55 to +125°C	0603
BLM18SG331TN1	330 ±25%	1500	0.070	-55 to +125°C	0603

To operate at the temperature over +85°C, some of these items need derating of rated current. Please contact us for details.

EMIFIL® (Inductor Type)

Chip Ferrite Bead for GHz Noise

Equivalent Circuit

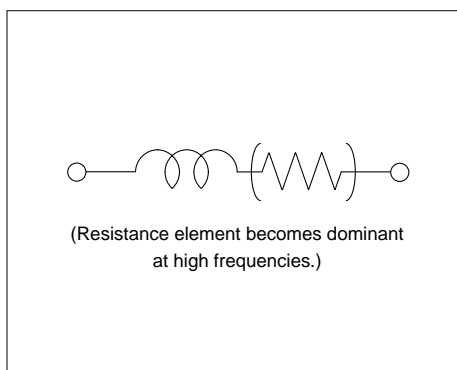

● BLM15H Series

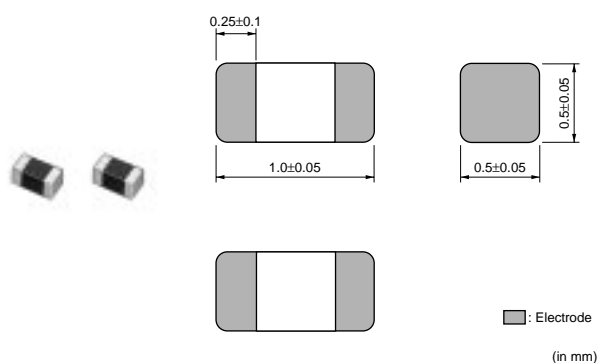

Impedance-Frequency Characteristics (Main Items)

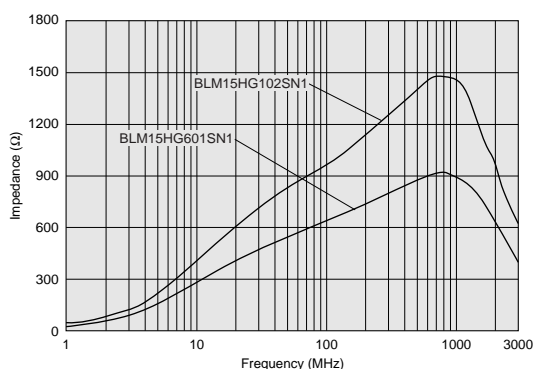

Part Number	Impedance (at 100MHz/20°C) (ohm)	Impedance (at 1GHz/20°C) (ohm)	Rated Current (mA)	DC Resistance (max.) (ohm)	Operating Temperature Range	Case Size
BLM15HG601SN1	600 ±25%	1000 ±40%	300	0.7	-55 to +125°C	0402
BLM15HG102SN1	1000 ±25%	1400 ±40%	250	1.1	-55 to +125°C	0402
BLM15HB121SN1	120 ±25%	500 ±40%	300	0.7	-55 to +125°C	0402
BLM15HB221SN1	220 ±25%	900 ±40%	250	1.0	-55 to +125°C	0402
BLM15HD601SN1	600 ±25%	1400 ±40%	300	0.85	-55 to +125°C	0402
BLM15HD102SN1	1000 ±25%	2000 ±40%	250	1.25	-55 to +125°C	0402
BLM15HD182SN1	1800 ±25%	2700 ±40%	200	2.2	-55 to +125°C	0402

● BLM15E Series

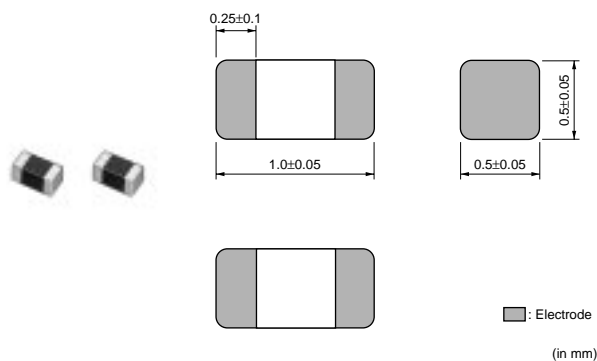

Impedance-Frequency Characteristics (Main Items)

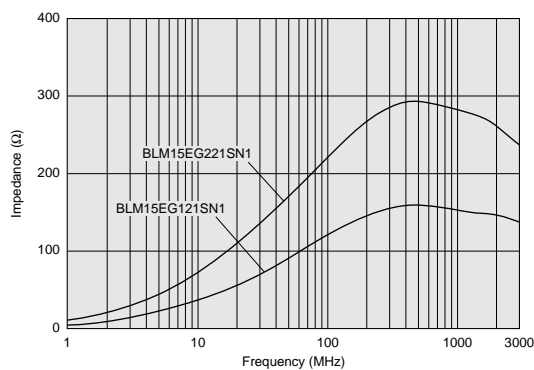

⚠Note • This PDF catalog is downloaded from the website of Murata Manufacturing co., ltd. Therefore, it's specifications are subject to change or our products in it may be discontinued without advance notice. Please check with our sales representatives or product engineers before ordering.
• This PDF catalog has only typical specifications because there is no space for detailed specifications. Therefore, please approve our product specifications or transact the approval sheet for product specifications before ordering.

Part Number	Impedance (at 100MHz/20°C) (ohm)	Impedance (at 1GHz/20°C) (ohm)	Rated Current (mA)	DC Resistance (max.) (ohm)	Operating Temperature Range	Case Size
BLM15EG121SN1	120 ±25%	145 (Typ.)	1500	0.095	-55 to +125°C	0402
BLM15EG221SN1	220 ±25%	270 (Typ.)	700	0.28	-55 to +125°C	0402

To operate at the temperature over +85°C, some of these items need derating of rated current. Please contact us for details.

● BLM18H Series

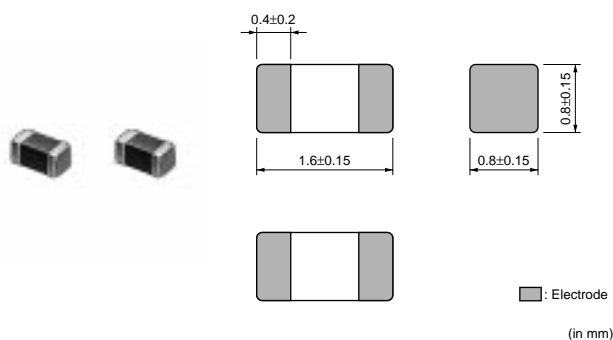

Impedance-Frequency Characteristics (Main Items)

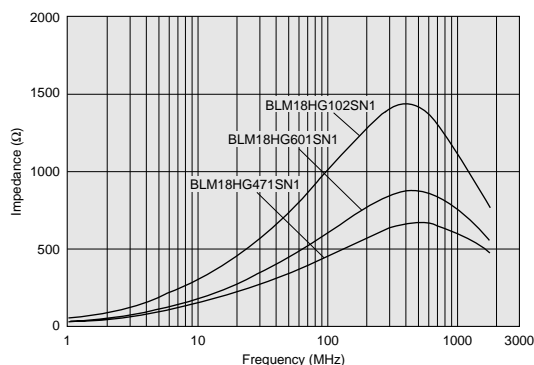

Part Number	Impedance (at 100MHz/20°C) (ohm)	Impedance (at 1GHz/20°C) (ohm)	Rated Current (mA)	DC Resistance (max.) (ohm)	Operating Temperature Range	Case Size
BLM18HG471SN1	470 ±25%	600 (Typ.)	200	0.85	-55 to +125°C	0603
BLM18HG601SN1	600 ±25%	700 (Typ.)	200	1.00	-55 to +125°C	0603
BLM18HG102SN1	1000 ±25%	1000 (Typ.)	100	1.60	-55 to +125°C	0603
BLM18HB121SN1	120 ±25%	500 ±40%	200	0.50	-55 to +125°C	0603
BLM18HB221SN1	220 ±25%	1100 ±40%	100	0.80	-55 to +125°C	0603
BLM18HB331SN1	330 ±25%	1600 ±40%	50	1.20	-55 to +125°C	0603
BLM18HD471SN1	470 ±25%	1000 (Typ.)	100	1.20	-55 to +125°C	0603
BLM18HD601SN1	600 ±25%	1200 (Typ.)	100	1.50	-55 to +125°C	0603
BLM18HD102SN1	1000 ±25%	1700 (Typ.)	50	1.80	-55 to +125°C	0603
BLM18HE601SN1	600 ±25%	600 (Typ.)	800	0.25	-55 to +125°C	0603
BLM18HE102SN1	1000 ±25%	1000 (Typ.)	600	0.35	-55 to +125°C	0603
BLM18HE152SN1	1500 ±25%	1500 (Typ.)	500	0.50	-55 to +125°C	0603
BLM18HK331SN1	330 ±25%	400 ±40%	200	0.50	-55 to +125°C	0603
BLM18HK471SN1	470 ±25%	600 ±40%	200	0.70	-55 to +125°C	0603
BLM18HK601SN1	600 ±25%	700 ±40%	100	0.90	-55 to +125°C	0603
BLM18HK102SN1	1000 ±25%	1200 ±40%	50	1.50	-55 to +125°C	0603

To operate at the temperature over +85°C, some of these items need derating of rated current. Please contact us for details.

● BLM18E Series

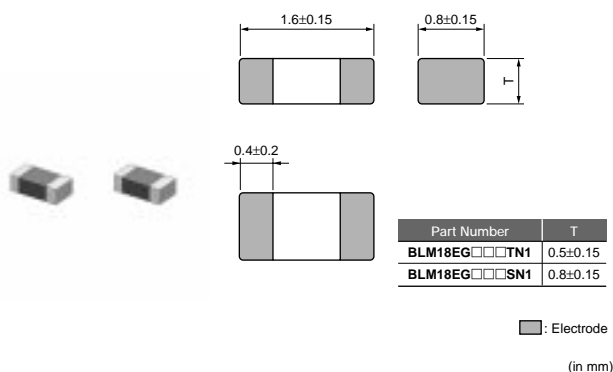

Impedance-Frequency Characteristics (Main Items)

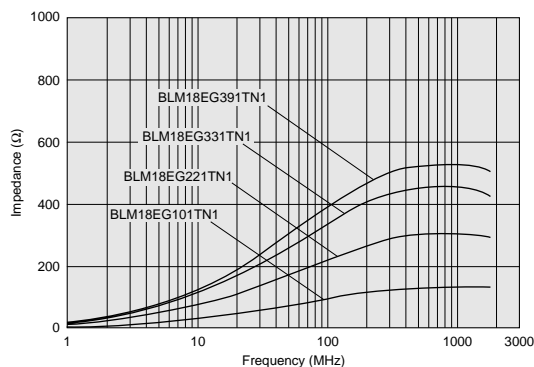

Part Number	Impedance (at 100MHz/20°C) (ohm)	Impedance (at 1GHz/20°C) (ohm)	Rated Current (mA)	DC Resistance (max.) (ohm)	Operating Temperature Range	Case Size
BLM18EG101TN1	100 ±25%	140 (Typ.)	2000	0.045	-55 to +125°C	0603
BLM18EG121SN1	120 ±25%	145 (Typ.)	2000	0.04	-55 to +125°C	0603
BLM18EG221SN1	220 ±25%	260 (Typ.)	2000	0.05	-55 to +125°C	0603
BLM18EG221TN1	220 ±25%	300 (Typ.)	1000	0.15	-55 to +125°C	0603
BLM18EG331TN1	330 ±25%	450 (Typ.)	500	0.21	-55 to +125°C	0603
BLM18EG391TN1	390 ±25%	520 (Typ.)	500	0.3	-55 to +125°C	0603
BLM18EG471SN1	470 ±25%	550 (Typ.)	500	0.21	-55 to +125°C	0603
BLM18EG601SN1	600 ±25%	700 (Typ.)	500	0.35	-55 to +125°C	0603

To operate at the temperature over +85°C, some of these items need derating of rated current. Please contact us for details.

EMIFIL® (Inductor Type)

Chip Ferrite Bead for High-GHz Noise

Equivalent Circuit

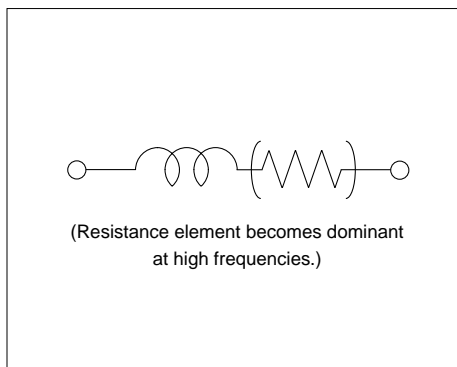

● BLM15G Series

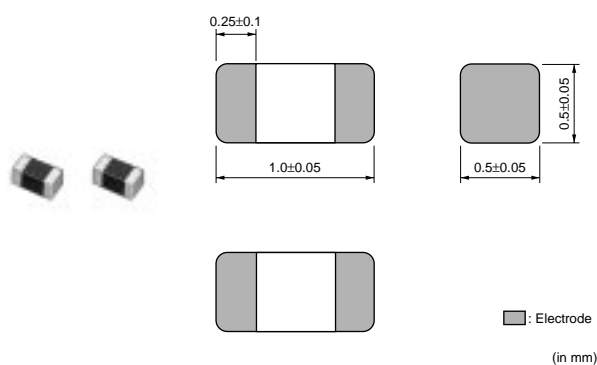

Impedance-Frequency Characteristics (Main Items)

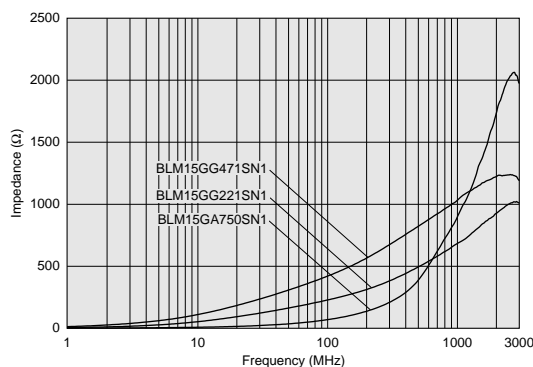

Part Number	Impedance (at 100MHz/20°C) (ohm)	Rated Current (mA)	DC Resistance (max.) (ohm)	Operating Temperature Range	Case Size
BLM15GA750SN1	75 ±25%	200	1.3	-55 to +125°C	0402
BLM15GG221SN1	220 ±25%	300	0.7	-55 to +125°C	0402
BLM15GG471SN1	470 ±25%	200	1.3	-55 to +125°C	0402

△Note • This PDF catalog is downloaded from the website of Murata Manufacturing co., ltd. Therefore, it's specifications are subject to change or our products in it may be discontinued without advance notice. Please check with our sales representatives or product engineers before ordering.
• This PDF catalog has only typical specifications because there is no space for detailed specifications. Therefore, please approve our product specifications or transact the approval sheet for product specifications before ordering.

● BLM18G Series

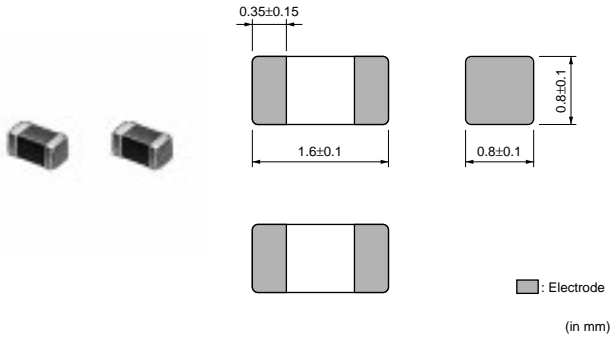

Impedance-Frequency Characteristics (Main Items)

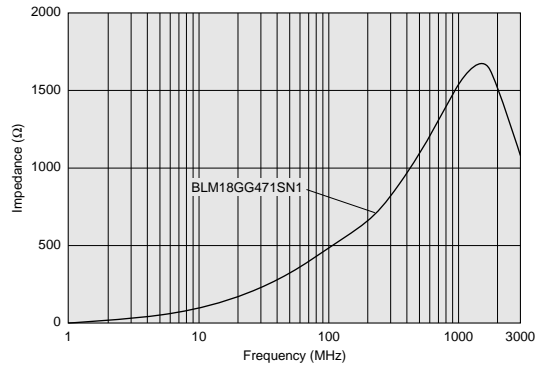

Part Number	Impedance (at 100MHz/20°C) (ohm)	Rated Current (mA)	DC Resistance (max.) (ohm)	Operating Temperature Range	Case Size
BLM18GG471SN1	470 ±25%	200	1.30	-55 to +125°C	0603

EMIFIL® (Inductor Type)

Chip Ferrite Bead (Array)

Equivalent Circuit

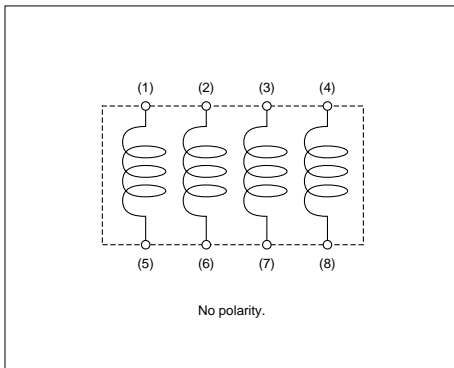

● BLA2A Series

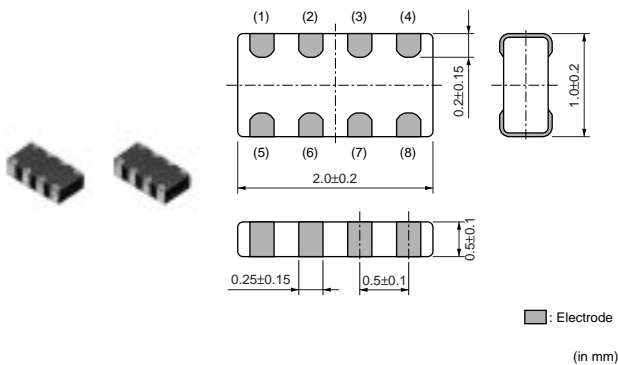

Impedance-Frequency Characteristics (Main Items)

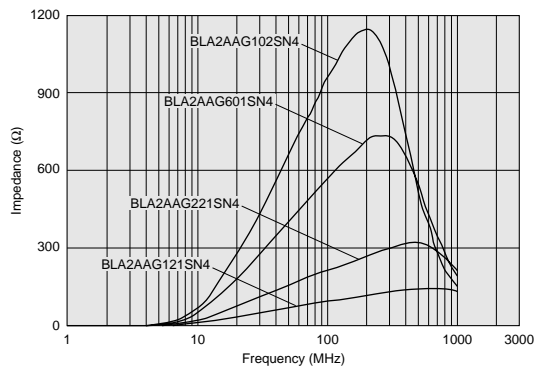

Part Number	Impedance (at 100MHz/20°C) (ohm)	Rated Current (mA)	DC Resistance (max.) (ohm)	Operating Temperature Range	Case Size
BLA2AAG121SN4	120 ±25%	100	0.50	-55 to +125°C	0804
BLA2AAG221SN4	220 ±25%	50	0.70	-55 to +125°C	0804
BLA2AAG601SN4	600 ±25%	50	1.10	-55 to +125°C	0804
BLA2AAG102SN4	1000 ±25%	50	1.30	-55 to +125°C	0804
BLA2ABB100SN4	10 ±25%	200	0.1	-55 to +125°C	0804
BLA2ABB220SN4	22 ±25%	200	0.2	-55 to +125°C	0804

Continued on the following page.

⚠️Note • This PDF catalog is downloaded from the website of Murata Manufacturing co., Ltd. Therefore, it's specifications are subject to change or our products in it may be discontinued without advance notice. Please check with our sales representatives or product engineers before ordering.
• This PDF catalog has only typical specifications because there is no space for detailed specifications. Therefore, please approve our product specifications or transact the approval sheet for product specifications before ordering.

Continued from the preceding page.

Part Number	Impedance (at 100MHz/20°C) (ohm)	Rated Current (mA)	DC Resistance (max.) (ohm)	Operating Temperature Range	Case Size
BLA2ABB470SN4	47 ±25%	200	0.35	-55 to +125°C	0804
BLA2ABB121SN4	120 ±25%	50	0.60	-55 to +125°C	0804
BLA2ABB221SN4	220 ±25%	50	0.90	-55 to +125°C	0804
BLA2ABD750SN4	75 ±25%	200	0.20	-55 to +125°C	0804
BLA2ABD121SN4	120 ±25%	200	0.35	-55 to +125°C	0804
BLA2ABD221SN4	220 ±25%	100	0.40	-55 to +125°C	0804
BLA2ABD471SN4	470 ±25%	100	0.65	-55 to +125°C	0804
BLA2ABD601SN4	600 ±25%	100	0.80	-55 to +125°C	0804
BLA2ABD102SN4	1000 ±25%	50	1.00	-55 to +125°C	0804

Number of Circuits: 4

● BLA31 Series

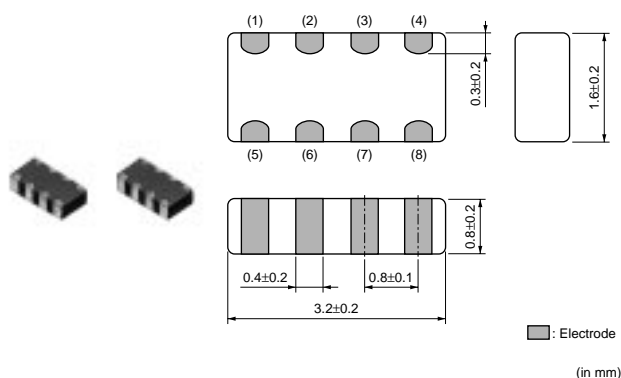

Impedance-Frequency Characteristics (Main Items)

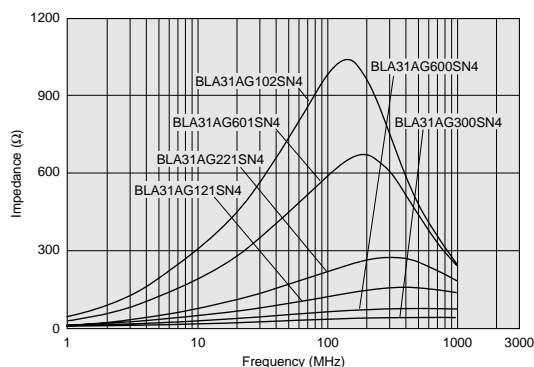

Part Number	Impedance (at 100MHz/20°C) (ohm)	Rated Current (mA)	DC Resistance (max.) (ohm)	Operating Temperature Range	Case Size
BLA31AG300SN4	30 ±25%	200	0.10	-55 to +125°C	1206
BLA31AG600SN4	60 ±25%	200	0.15	-55 to +125°C	1206
BLA31AG121SN4	120 ±25%	150	0.20	-55 to +125°C	1206
BLA31AG221SN4	220 ±25%	150	0.25	-55 to +125°C	1206
BLA31AG601SN4	600 ±25%	100	0.35	-55 to +125°C	1206
BLA31AG102SN4	1000 ±25%	50	0.45	-55 to +125°C	1206
BLA31BD121SN4	120 ±25%	150	0.30	-55 to +125°C	1206
BLA31BD221SN4	220 ±25%	150	0.35	-55 to +125°C	1206
BLA31BD471SN4	470 ±25%	100	0.40	-55 to +125°C	1206
BLA31BD601SN4	600 ±25%	100	0.45	-55 to +125°C	1206
BLA31BD102SN4	1000 ±25%	50	0.55	-55 to +125°C	1206

Number of Circuits: 4

△Note • This PDF catalog is downloaded from the website of Murata Manufacturing co., ltd. Therefore, it's specifications are subject to change or our products in it may be discontinued without advance notice. Please check with our sales representatives or product engineers before ordering.
• This PDF catalog has only typical specifications because there is no space for detailed specifications. Therefore, please approve our product specifications or transact the approval sheet for product specifications before ordering.

EMIFIL® (Capacitor Type)

Single Circuit Type for Signal Lines

Equivalent Circuit

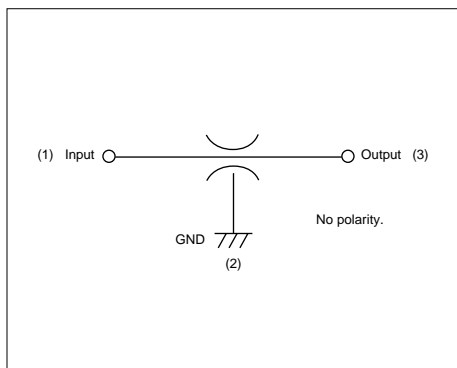

Noise Suppression Products/EMI Suppression Filters

2

● NFM18C Series (0603)

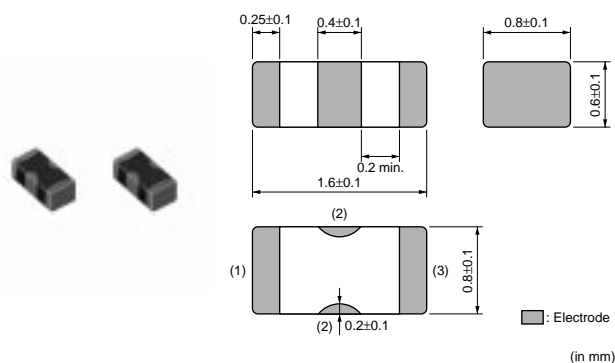

Insertion Loss Characteristics (Main Items)

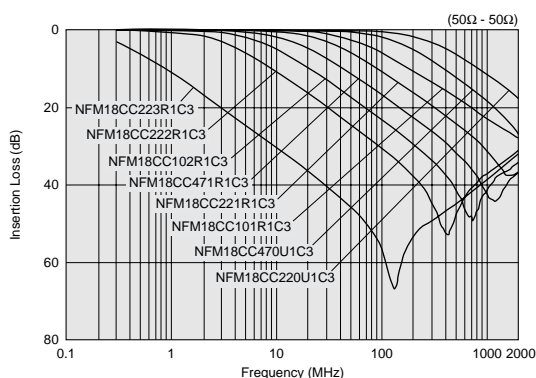

Part Number	Capacitance (pF)	Rated Voltage (Vdc)	Rated Current (mA)	Insulation Resistance (min.) (M ohm)	Operating Temperature Range
NFM18CC220U1C3	22 ±20%	16	400	1000	-55 to +125°C
NFM18CC470U1C3	47 ±20%	16	400	1000	-55 to +125°C
NFM18CC101R1C3	100 ±20%	16	500	1000	-55 to +125°C
NFM18CC221R1C3	220 ±20%	16	500	1000	-55 to +125°C
NFM18CC471R1C3	470 ±20%	16	500	1000	-55 to +125°C
NFM18CC102R1C3	1000 ±20%	16	600	1000	-55 to +125°C
NFM18CC222R1C3	2200 ±20%	16	700	1000	-55 to +125°C
NFM18CC223R1C3	22000 ±20%	16	1000	1000	-55 to +125°C

● NFM21C Series (0805)

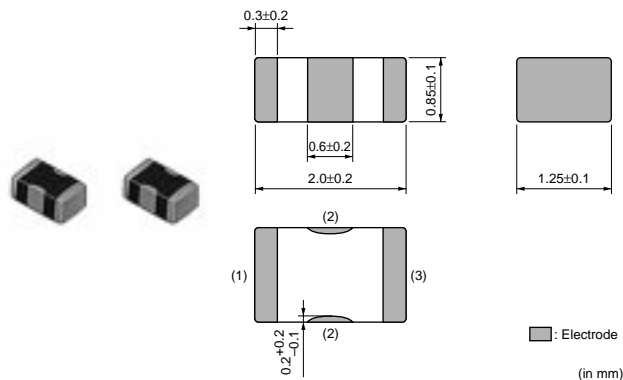

Insertion Loss Characteristics (Main Items)

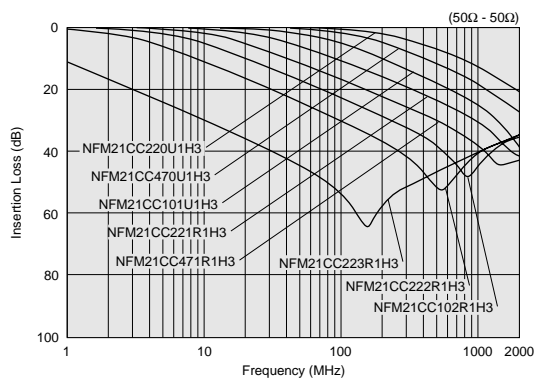

Note • This PDF catalog is downloaded from the website of Murata Manufacturing co., Ltd. Therefore, it's specifications are subject to change or our products in it may be discontinued without advance notice. Please check with our sales representatives or product engineers before ordering.
• This PDF catalog has only typical specifications because there is no space for detailed specifications. Therefore, please approve our product specifications or transact the approval sheet for product specifications before ordering.

Part Number	Capacitance (pF)	Rated Voltage (Vdc)	Rated Current (mA)	Insulation Resistance (min.) (M ohm)	Operating Temperature Range
NFM21CC220U1H3	22 ±20%	50	700	1000	-55 to +125°C
NFM21CC470U1H3	47 ±20%	50	700	1000	-55 to +125°C
NFM21CC101U1H3	100 ±20%	50	700	1000	-55 to +125°C
NFM21CC221R1H3	220 ±20%	50	700	1000	-55 to +125°C
NFM21CC471R1H3	470 ±20%	50	1000	1000	-55 to +125°C
NFM21CC102R1H3	1000 ±20%	50	1000	1000	-55 to +125°C
NFM21CC222R1H3	2200 ±20%	50	1000	1000	-55 to +125°C
NFM21CC223R1H3	22000 ±20%	50	2000	1000	-55 to +125°C

● NFM3DC Series (1205)

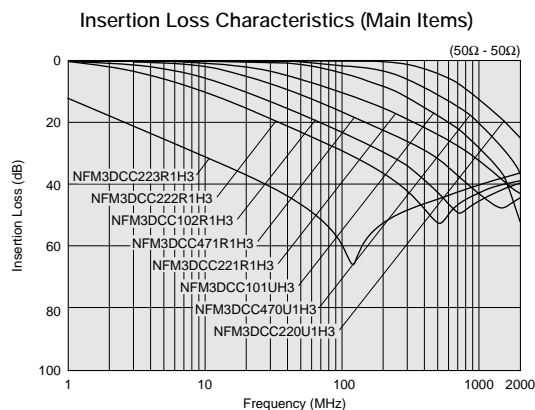
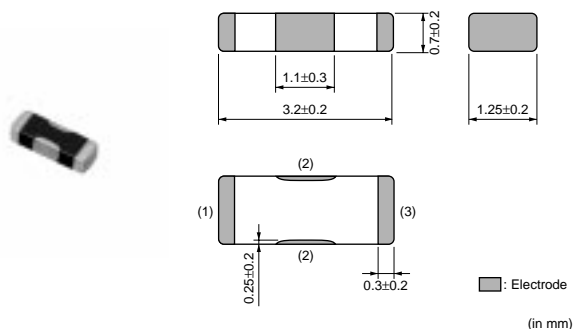

Part Number	Capacitance (pF)	Rated Voltage (Vdc)	Rated Current (mA)	Insulation Resistance (min.) (M ohm)	Operating Temperature Range
NFM3DCC220U1H3	22 50/-20%	50	300	1000	-55 to +125°C
NFM3DCC470U1H3	47 50/-20%	50	300	1000	-55 to +125°C
NFM3DCC101U1H3	100 50/-20%	50	300	1000	-55 to +125°C
NFM3DCC221R1H3	220 50/-20%	50	300	1000	-55 to +125°C
NFM3DCC471R1H3	470 50/-20%	50	300	1000	-55 to +125°C
NFM3DCC102R1H3	1000 50/-20%	50	300	1000	-55 to +125°C
NFM3DCC222R1H3	2200 50/-20%	50	300	1000	-55 to +125°C
NFM3DCC223R1H3	22000 50/-20%	50	300	1000	-55 to +125°C

● NFM41C Series (1806)

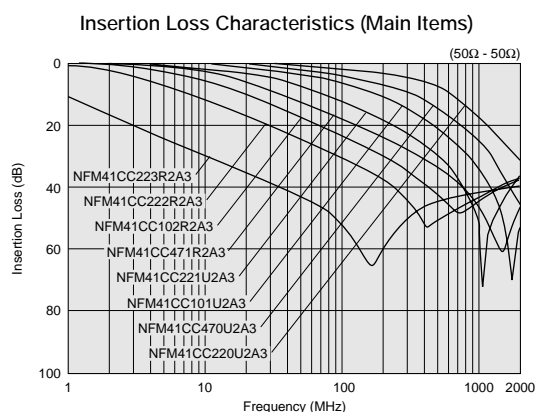
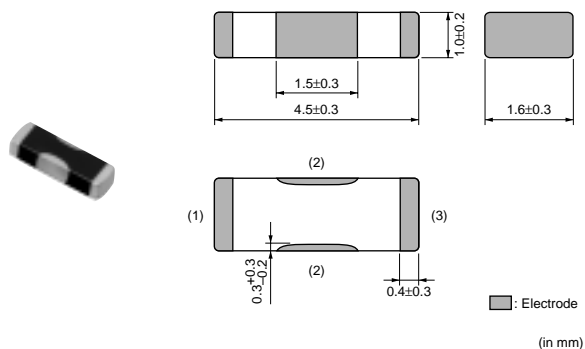

Part Number	Capacitance (pF)	Rated Voltage (Vdc)	Rated Current (mA)	Insulation Resistance (min.) (M ohm)	Operating Temperature Range
NFM41CC220U2A3	22 50/-20%	100	300	10000	-55 to +125°C
NFM41CC470U2A3	47 50/-20%	100	300	10000	-55 to +125°C
NFM41CC101U2A3	100 50/-20%	100	300	10000	-55 to +125°C

Continued on the following page.

△Note • This PDF catalog is downloaded from the website of Murata Manufacturing co., ltd. Therefore, it's specifications are subject to change or our products in it may be discontinued without advance notice. Please check with our sales representatives or product engineers before ordering.
 • This PDF catalog has only typical specifications because there is no space for detailed specifications. Therefore, please approve our product specifications or transact the approval sheet for product specifications before ordering.

Continued from the preceding page.

Part Number	Capacitance (pF)	Rated Voltage (Vdc)	Rated Current (mA)	Insulation Resistance (min.) (M ohm)	Operating Temperature Range
NFM41CC221U2A3	220 50/-20%	100	300	10000	-55 to +125°C
NFM41CC471R2A3	470 50/-20%	100	300	10000	-55 to +125°C
NFM41CC102R2A3	1000 50/-20%	100	300	10000	-55 to +125°C
NFM41CC222R2A3	2200 50/-20%	100	300	10000	-55 to +125°C
NFM41CC223R2A3	22000 50/-20%	100	300	10000	-55 to +125°C

EMIFIL® (Capacitor Type)

Single Circuit Type for Large Current

Equivalent Circuit

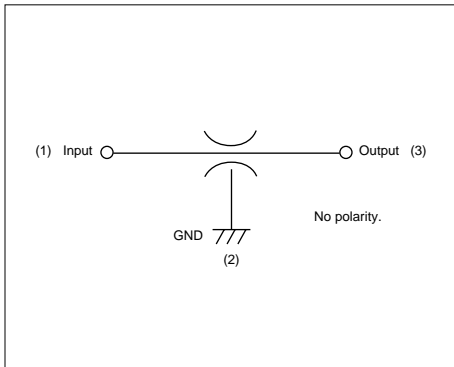

● NFM18P (0603)/NFM21P (0805)/NFM3DP (1205)/NFM31P (1206)/NFM41P (1806)/NFM55P (2220) Series



NFM18PC Series

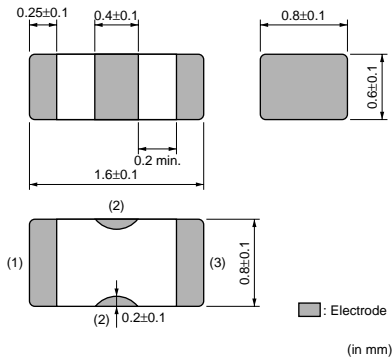

Insertion Loss Characteristics (Main Items)

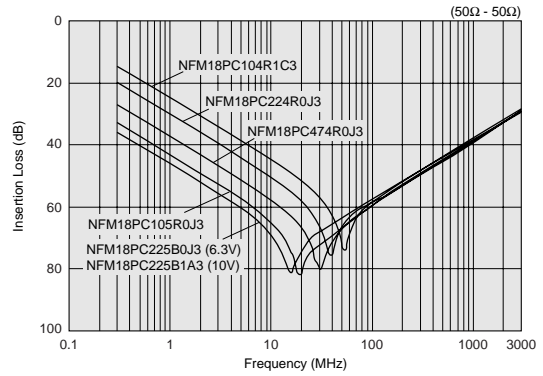

NFM18PC105R0J3
NFM18PC225B1A3

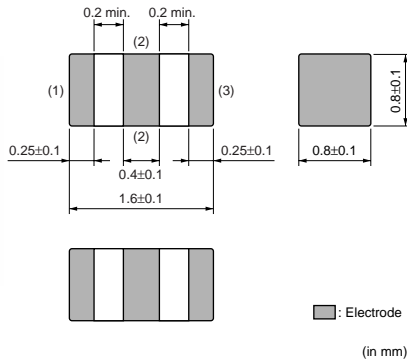

Continued on the following page.

Note • This PDF catalog is downloaded from the website of Murata Manufacturing co., ltd. Therefore, it's specifications are subject to change or our products in it may be discontinued without advance notice. Please check with our sales representatives or product engineers before ordering.
 • This PDF catalog has only typical specifications because there is no space for detailed specifications. Therefore, please approve our product specifications or transact the approval sheet for product specifications before ordering.

Continued from the preceding page.



NFM18PS Series

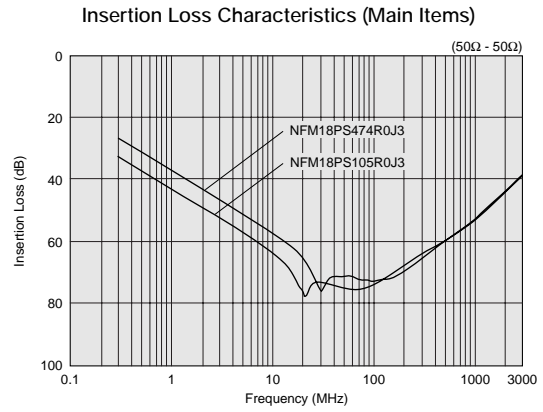
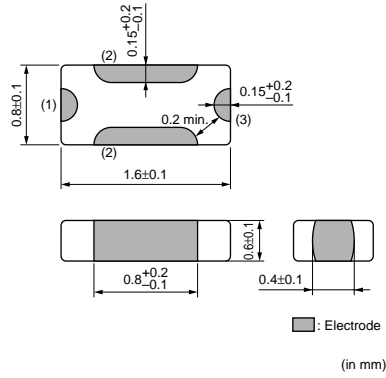

NFM21P Series

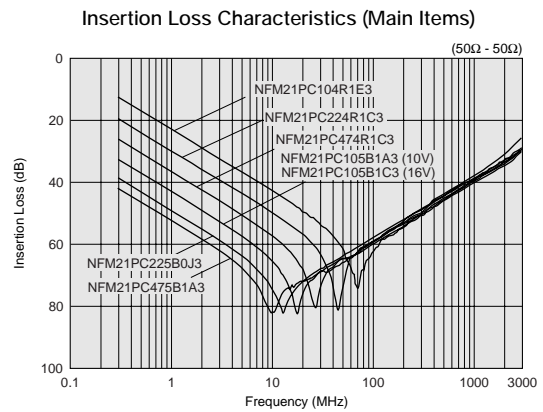
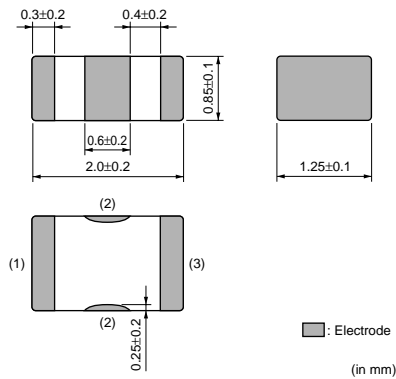

NFM3DP Series

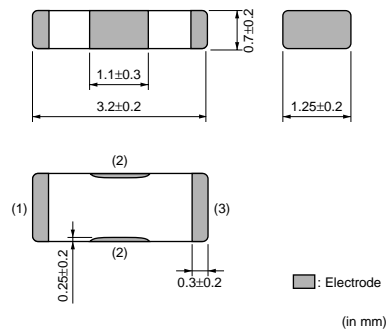

NFM31P Series

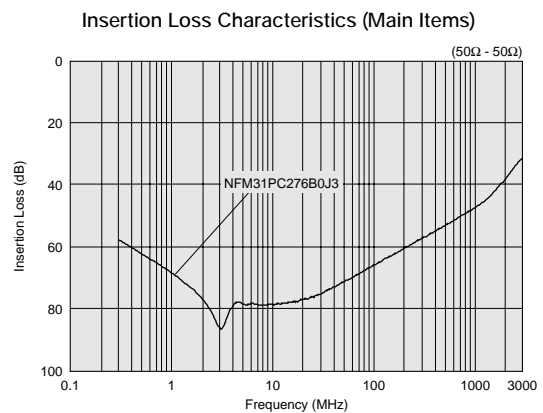
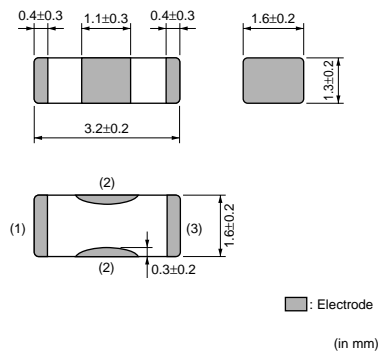

Continued on the following page.

Note • This PDF catalog is downloaded from the website of Murata Manufacturing co., ltd. Therefore, it's specifications are subject to change or our products in it may be discontinued without advance notice. Please check with our sales representatives or product engineers before ordering.
 • This PDF catalog has only typical specifications because there is no space for detailed specifications. Therefore, please approve our product specifications or transact the approval sheet for product specifications before ordering.

Continued from the preceding page.



NFM41P Series

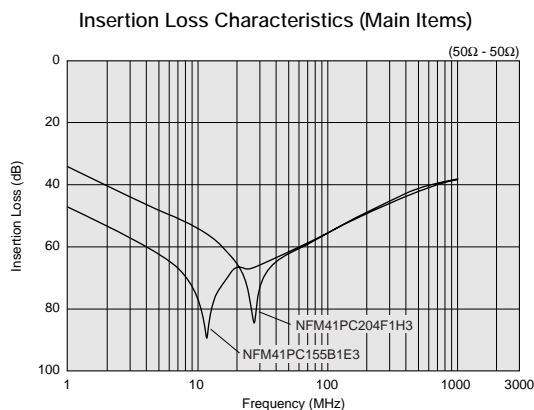
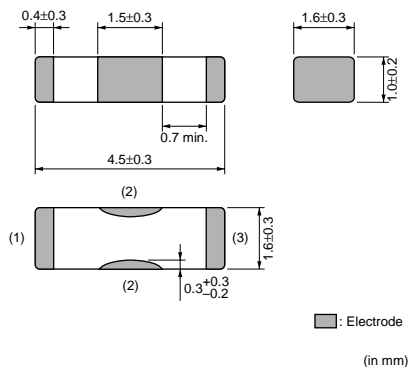

NFM55P Series

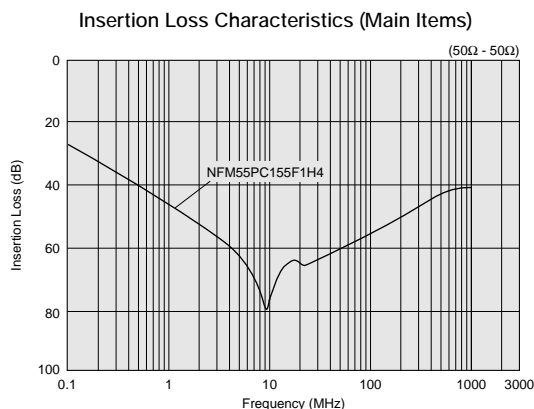
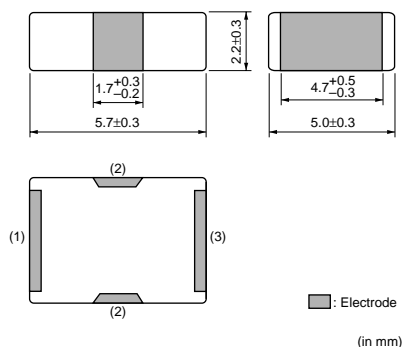

Part Number	Capacitance (μF)	Rated Voltage (Vdc)	Rated Current (A)	Insulation Resistance (min.) (M ohm)	Operating Temperature Range
NFM18PC104R1C3	0.1 ±20%	16	2	1000	-55 to +125°C
NFM18PC224R0J3	0.22 ±20%	6.3	2	1000	-55 to +125°C
NFM18PC474R0J3	0.47 ±20%	6.3	2	1000	-55 to +125°C
NFM18PC105R0J3	1.0 ±20%	6.3	2	500	-55 to +105°C
NFM18PC225B0J3	2.2 ±20%	6.3	2	200	-40 to +85°C
NFM18PC225B1A3	2.2 ±20%	10	4	200	-40 to +85°C
NFM18PS474R0J3	0.47 ±20%	6.3	2	1000	-55 to +125°C
NFM18PS105R0J3	1.0 ±20%	6.3	2	500	-55 to +105°C
NFM21PC104R1E3	0.1 ±20%	25	2	1000	-55 to +125°C
NFM21PC224R1C3	0.22 ±20%	16	2	1000	-55 to +125°C
NFM21PC474R1C3	0.47 ±20%	16	2	1000	-55 to +125°C
NFM21PC105B1A3	1.0 ±20%	10	4	500	-40 to +85°C
NFM21PC105B1C3	1.0 ±20%	16	4	500	-40 to +85°C
NFM21PC225B0J3	2.2 ±20%	6.3	4	200	-40 to +85°C
NFM21PC475B1A3	4.7 ±20%	10	6	100	-40 to +85°C
NFM3DPC223R1H3	0.022 ±20%	50	2	1000	-55 to +125°C
NFM31PC276B0J3	27 ±20%	6.3	6	20	-40 to +85°C
NFM41PC204F1H3	0.2 80/-20%	50	2	1000	-55 to +85°C
NFM41PC155B1E3	1.5 ±20%	25	6	300	-55 to +85°C
NFM55PC155F1H4	1.5 80/-20%	50	6	100	-55 to +85°C

EMIFIL® (Capacitor Type)

Array

● NFA31C Series (1206)

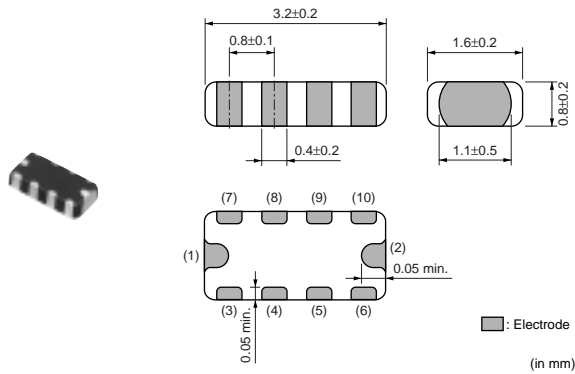

Insertion Loss Characteristics (Main Items)

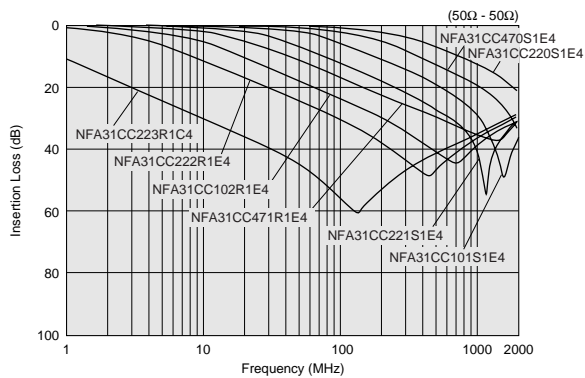

Equivalent Circuit

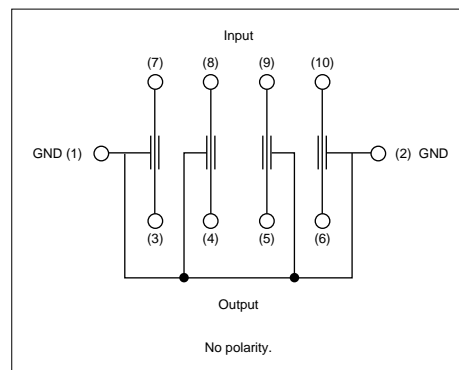

Part Number	Capacitance (pF)	Rated Voltage (Vdc)	Rated Current (mA)	Insulation Resistance (min.) (M ohm)	Operating Temperature Range
NFA31CC220S1E4	22 ±20%	25	200	1000	-40 to +85°C
NFA31CC470S1E4	47 ±20%	25	200	1000	-40 to +85°C
NFA31CC101S1E4	100 ±20%	25	200	1000	-40 to +85°C
NFA31CC221S1E4	220 ±20%	25	200	1000	-40 to +85°C
NFA31CC471R1E4	470 ±20%	25	200	1000	-40 to +85°C
NFA31CC102R1E4	1000 ±20%	25	200	1000	-40 to +85°C
NFA31CC222R1E4	2200 ±20%	25	200	1000	-40 to +85°C
NFA31CC223R1C4	22000 ±20%	16	200	1000	-40 to +85°C

Number of Circuit: 4

2
Noise Suppression Products/EMI Suppression Filters

△Note • This PDF catalog is downloaded from the website of Murata Manufacturing co., ltd. Therefore, it's specifications are subject to change or our products in it may be discontinued without advance notice. Please check with our sales representatives or product engineers before ordering.
• This PDF catalog has only typical specifications because there is no space for detailed specifications. Therefore, please approve our product specifications or transact the approval sheet for product specifications before ordering.

EMIFIL[®] (LC Combined)

Feed Through Type

Equivalent Circuit

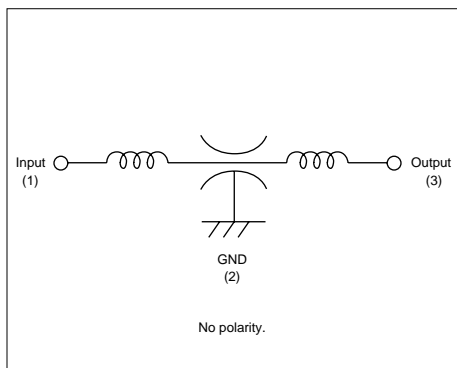

Noise Suppression Products/EMI Suppression Filters

2

● NFE31P Series (1206)

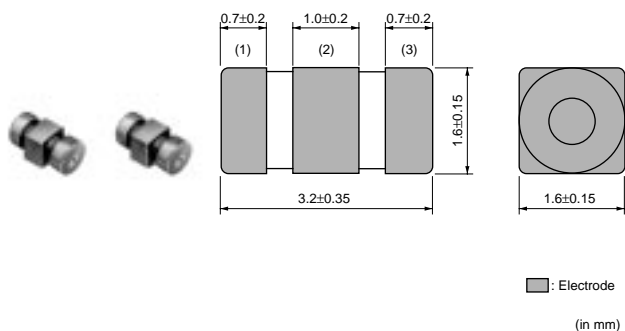

Insertion Loss Characteristics (Main Items)

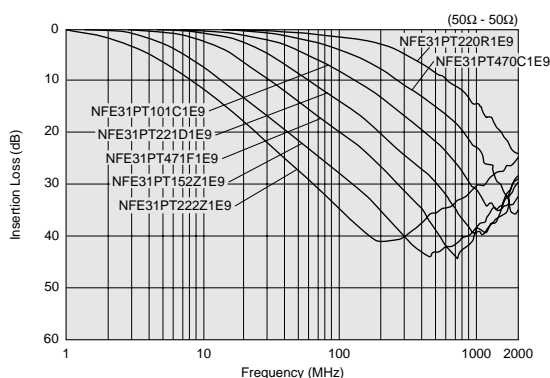

Part Number	Capacitance (pF)	Rated Voltage (Vdc)	Rated Current (A)	Insulation Resistance (min.) (M ohm)	Operating Temperature Range
NFE31PT220R1E9	22 ±30%	25	6	1000	-40 to +85°C
NFE31PT470C1E9	47 50/-20%	25	6	1000	-40 to +85°C
NFE31PT101C1E9	100 80/-20%	25	6	1000	-40 to +85°C
NFE31PT221D1E9	220 50/-20%	25	6	1000	-40 to +85°C
NFE31PT471F1E9	470 50/-20%	25	6	1000	-40 to +85°C
NFE31PT152Z1E9	1500 50/-20%	25	6	1000	-40 to +85°C
NFE31PT222Z1E9	2200 ±50%	25	6	1000	-40 to +85°C

● NFE61P Series (2606)

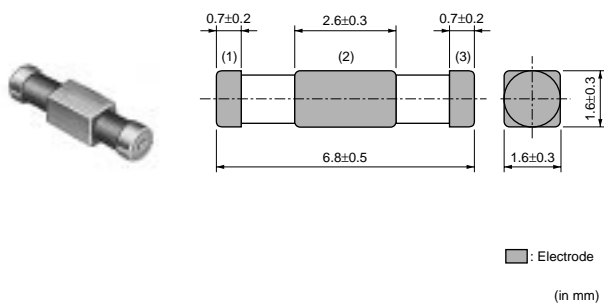

Insertion Loss Characteristics (Main Items)

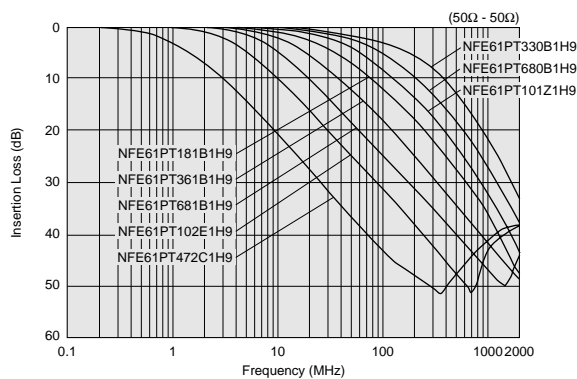

⚠Note • This PDF catalog is downloaded from the website of Murata Manufacturing co., Ltd. Therefore, it's specifications are subject to change or our products in it may be discontinued without advance notice. Please check with our sales representatives or product engineers before ordering.
• This PDF catalog has only typical specifications because there is no space for detailed specifications. Therefore, please approve our product specifications or transact the approval sheet for product specifications before ordering.

Part Number	Capacitance (pF)	Rated Voltage (Vdc)	Rated Current (A)	Insulation Resistance (min.) (M ohm)	Operating Temperature Range
NFE61PT330B1H9	33 ±30%	50	2	1000	-25 to +85°C
NFE61PT680B1H9	68 ±30%	50	2	1000	-25 to +85°C
NFE61PT101Z1H9	100 ±30%	50	2	1000	-25 to +85°C
NFE61PT181B1H9	180 ±30%	50	2	1000	-25 to +85°C
NFE61PT361B1H9	360 ±20%	50	2	1000	-25 to +85°C
NFE61PT681B1H9	680 ±30%	50	2	1000	-25 to +85°C
NFE61PT102E1H9	1000 80/-20%	50	2	1000	-25 to +85°C
NFE61PT472C1H9	4700 80/-20%	50	2	1000	-25 to +85°C

EMIFIL® (LC Combined)

Wire Wound Type

● for Signal Line NFW31S Series (1206)

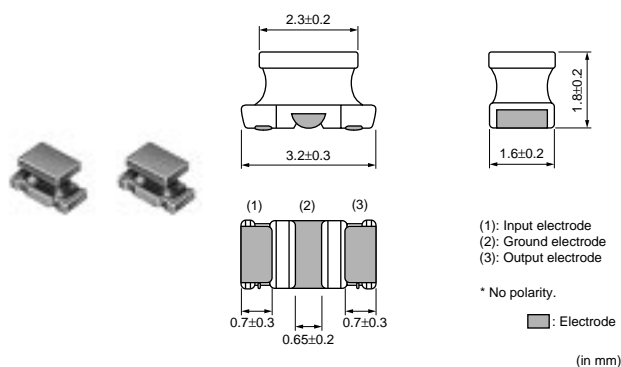

Insertion Loss Characteristics (Main Items)

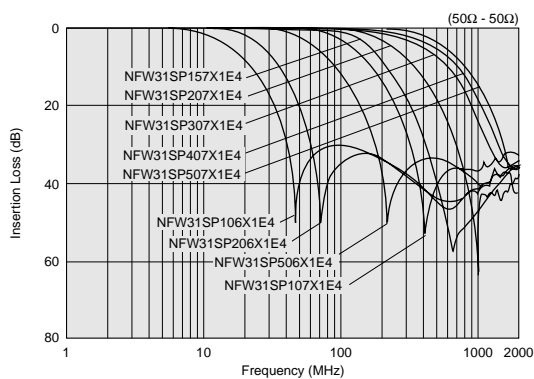

Equivalent Circuit

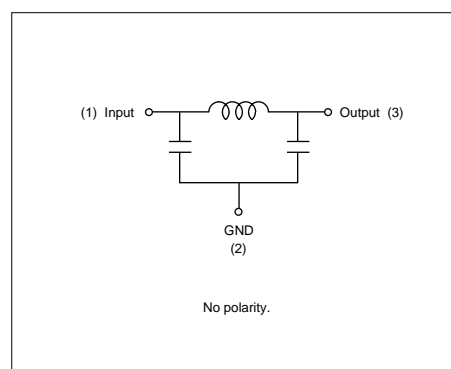

Part Number	Nominal Cut-off Freq. (MHz)	Insertion Loss at 10MHz (dB)	Insertion Loss at 20MHz (dB)	Insertion Loss at 50MHz (dB)	Insertion Loss at 100MHz (dB)	Insertion Loss at 150MHz (dB)	Insertion Loss at 200MHz (dB)	Insertion Loss at 300MHz (dB)	Insertion Loss at 400MHz (dB)	Insertion Loss at 500MHz (dB)	Insertion Loss at 1000MHz (dB)
NFW31SP106X1E4	10	6 max.	5 min.	25 min.	25 min.	-	25 min.	-	-	30 min.	30 min.
NFW31SP206X1E4	20	-	6 max.	5 min.	25 min.	-	25 min.	-	-	30 min.	30 min.
NFW31SP506X1E4	50	-	-	6 max.	10 min.	-	30 min.	-	-	30 min.	30 min.
NFW31SP107X1E4	100	-	-	-	6 max.	-	5 min.	-	-	20 min.	30 min.
NFW31SP157X1E4	150	-	-	-	-	6 max.	-	10 min.	20 min.	30 min.	30 min.
NFW31SP207X1E4	200	-	-	-	-	-	6 max.	-	-	10 min.	30 min.
NFW31SP307X1E4	300	-	-	-	-	-	-	6 max.	-	5 min.	15 min.
NFW31SP407X1E4	400	-	-	-	-	-	-	-	6 max.	-	10 min.
NFW31SP507X1E4	500	-	-	-	-	-	-	-	-	6 max.	10 min.

Rated Current: 200mA Rated Voltage: 25Vdc Operating Temperature Range: -40 to 85°C

△Note • This PDF catalog is downloaded from the website of Murata Manufacturing co., ltd. Therefore, it's specifications are subject to change or our products in it may be discontinued without advance notice. Please check with our sales representatives or product engineers before ordering.
• This PDF catalog has only typical specifications because there is no space for detailed specifications. Therefore, please approve our product specifications or transact the approval sheet for product specifications before ordering.

EMIFIL® (LC Combined)

Multilayer Type

● NFL18S Series (0603)

Noise Suppression Products/EMI Suppression Filters

2

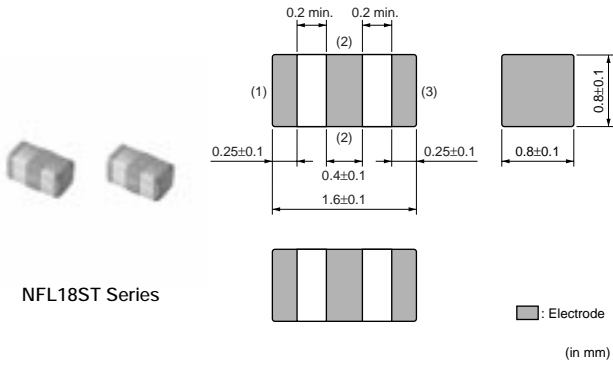

Insertion Loss Characteristics (Main Items)

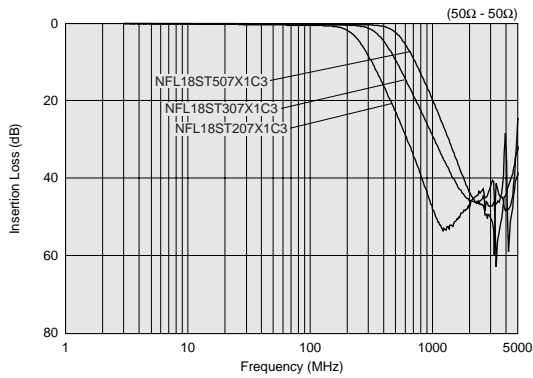

Equivalent Circuit

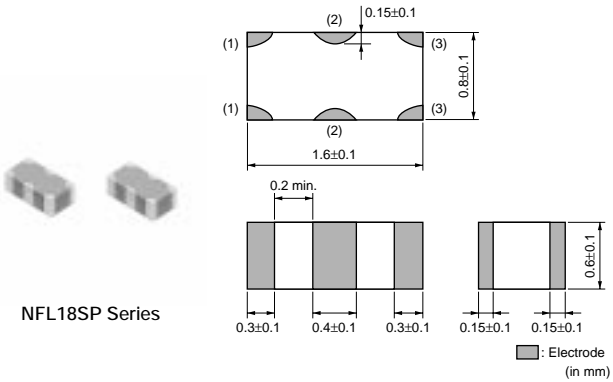
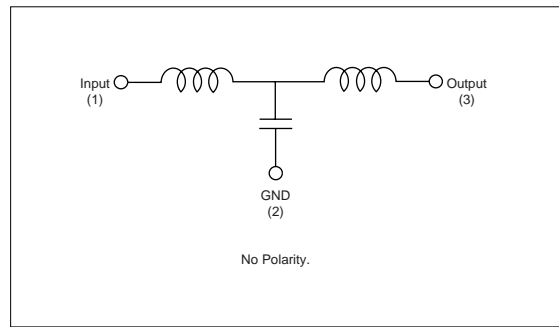

Insertion Loss Characteristics (Main Items)

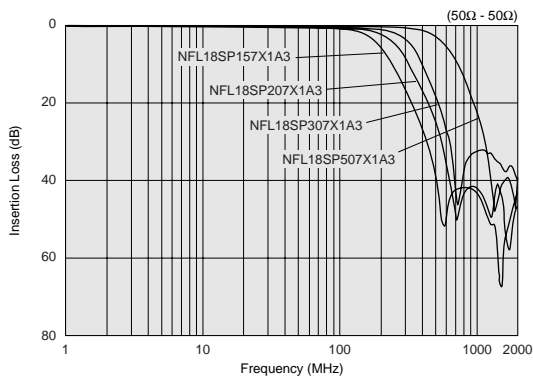

Equivalent Circuit

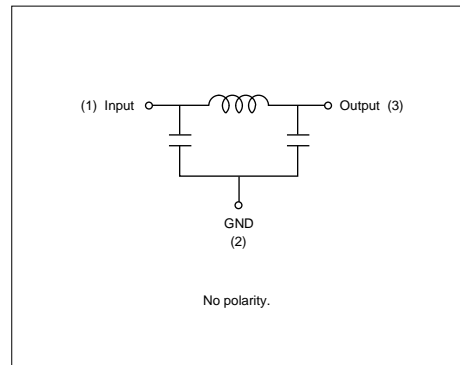

Part Number	Cut-off Frequency (MHz)	Capacitance (pF)	Inductance (nH)	Rated Voltage (Vdc)	Rated Current (mA)	Insulation Resistance (min.) (M ohm)	Operating Temperature Range
NFL18ST207X1C3	200	25 ±20%	110 ±20%	16	150	1000	-55 to +125°C
NFL18ST307X1C3	300	18 ±20%	62 ±20%	16	200	1000	-55 to +125°C
NFL18ST507X1C3	500	10 ±20%	43 ±20%	16	200	1000	-55 to +125°C
NFL18SP157X1A3	150	34 ±20%	100 ±20%	10	100	1000	-55 to +125°C
NFL18SP207X1A3	200	24 ±20%	80 ±20%	10	100	1000	-55 to +125°C
NFL18SP307X1A3	300	19 ±20%	60 ±20%	10	100	1000	-55 to +125°C
NFL18SP507X1A3	500	11 ±20%	38 ±20%	10	100	1000	-55 to +125°C

Number of Circuits: 1

● NFL21S Series (0805)

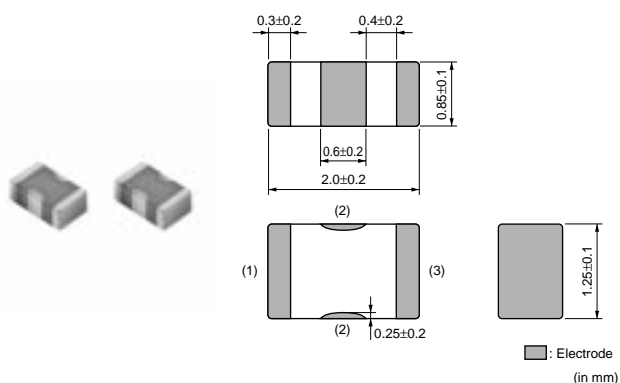

Insertion Loss Characteristics (Main Items)

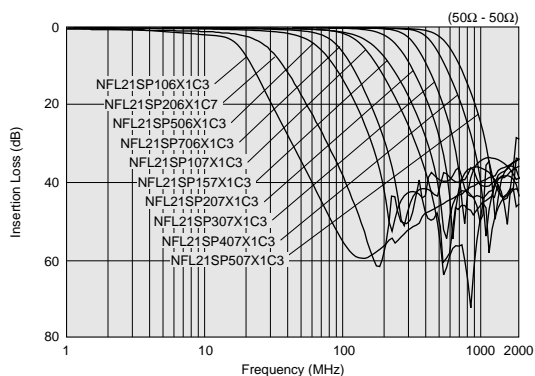

Equivalent Circuit

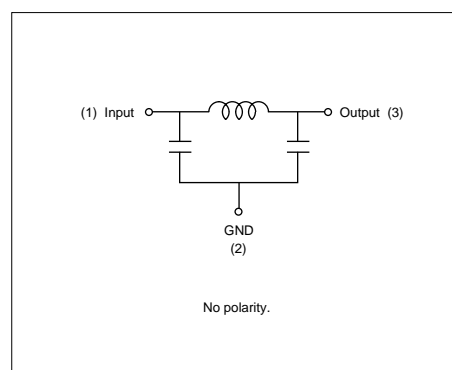

Part Number	Cut-off Frequency (MHz)	Capacitance (pF)	Inductance (nH)	Rated Voltage (Vdc)	Rated Current (mA)	Insulation Resistance (min.) (M ohm)	Operating Temperature Range
NFL21SP106X1C3	10	670 ±20%	680 ±20%	16	100	1000	-55 to +125°C
NFL21SP107X1C3	100	44 ±20%	135 ±20%	16	200	1000	-55 to +125°C
NFL21SP157X1C3	150	28 ±20%	128 ±20%	16	200	1000	-55 to +125°C
NFL21SP206X1C7	20	240 ±20%	700 ±20%	16	100	1000	-55 to +125°C
NFL21SP207X1C3	200	22 ±20%	72 ±20%	16	250	1000	-55 to +125°C
NFL21SP307X1C3	300	19 ±10%	45 ±10%	16	300	1000	-55 to +125°C
NFL21SP407X1C3	400	16 ±10%	34 ±10%	16	300	1000	-55 to +125°C
NFL21SP506X1C3	50	84 ±20%	305 ±20%	16	150	1000	-55 to +125°C
NFL21SP507X1C3	500	12 ±10%	31 ±10%	16	300	1000	-55 to +125°C
NFL21SP706X1C3	70	76 ±20%	185 ±20%	16	150	1000	-55 to +125°C

Number of Circuits: 1

⚠ Note • This PDF catalog is downloaded from the website of Murata Manufacturing co., ltd. Therefore, it's specifications are subject to change or our products in it may be discontinued without advance notice. Please check with our sales representatives or product engineers before ordering.
 • This PDF catalog has only typical specifications because there is no space for detailed specifications. Therefore, please approve our product specifications or transact the approval sheet for product specifications before ordering.

EMIFIL[®] (LC Combined)

Array

Noise Suppression Products/EMI Suppression Filters

2

● NFA18S Series (0603)

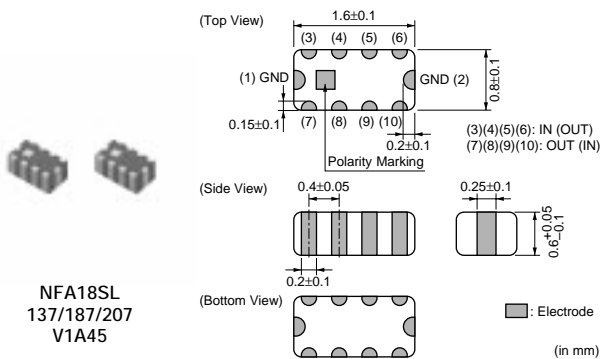

NFA18SL
137/187/207
V1A45

Insertion Loss Characteristics (Main Items)

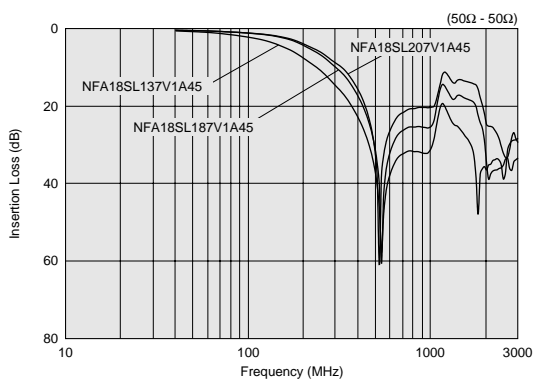

Equivalent Circuit

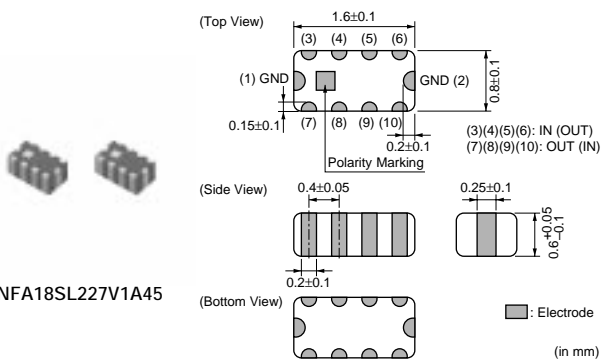
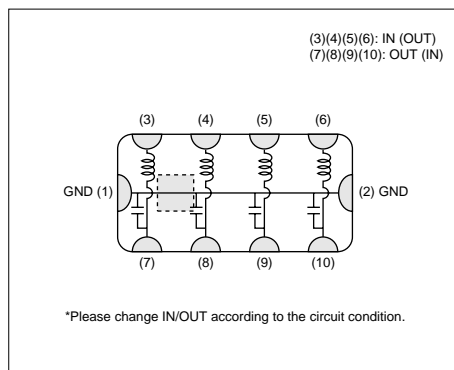

NFA18SL227V1A45

Insertion Loss Characteristics (Main Items)

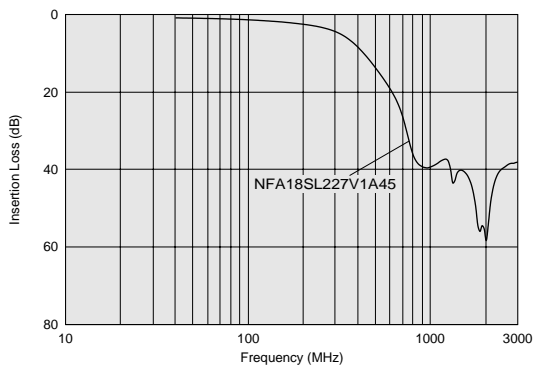

Equivalent Circuit

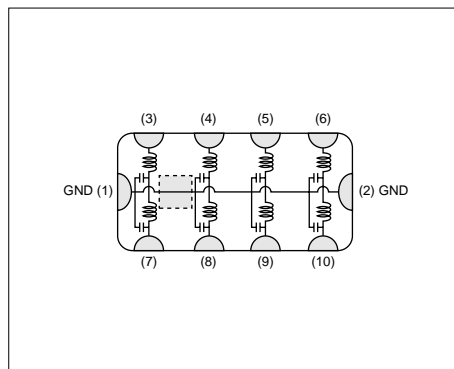

Continued on the following page.

Continued from the preceding page.

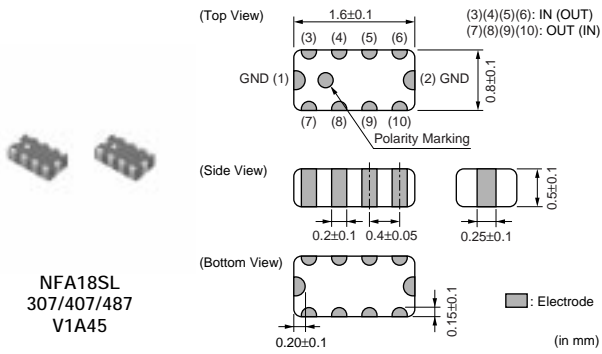

Insertion Loss Characteristics (Main Items)

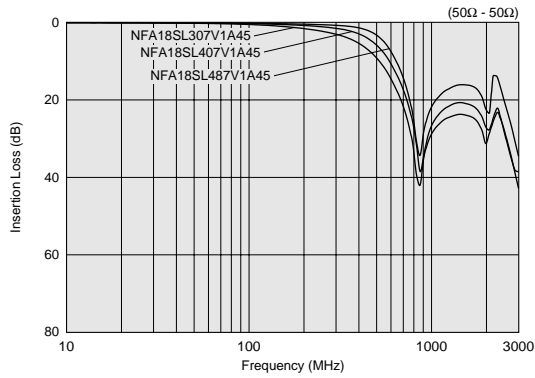

Equivalent Circuit

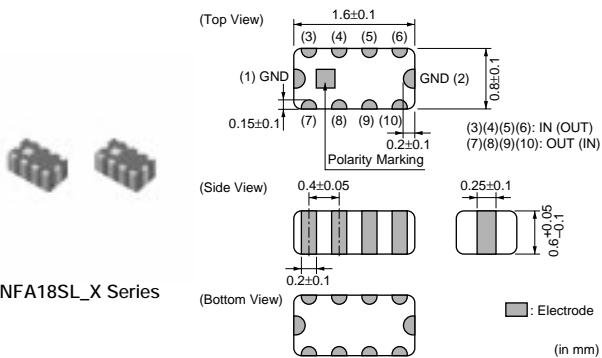
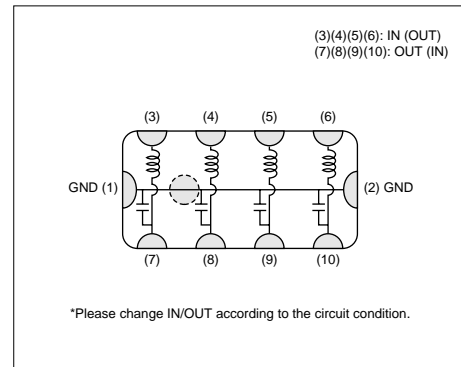

Insertion Loss Characteristics (Main Items)

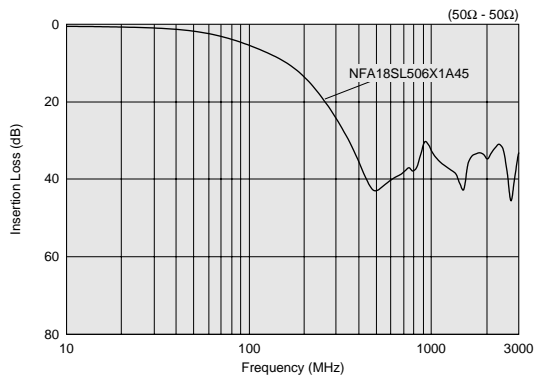

Equivalent Circuit

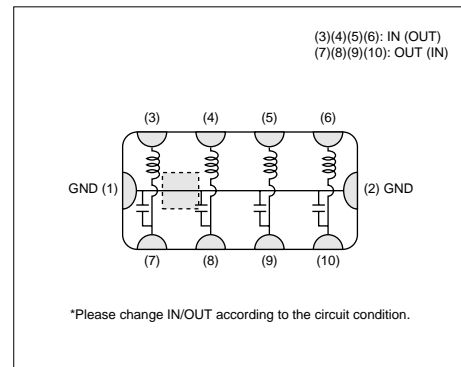

Continued on the following page.

Note • This PDF catalog is downloaded from the website of Murata Manufacturing co., ltd. Therefore, it's specifications are subject to change or our products in it may be discontinued without advance notice. Please check with our sales representatives or product engineers before ordering.
• This PDF catalog has only typical specifications because there is no space for detailed specifications. Therefore, please approve our product specifications or transact the approval sheet for product specifications before ordering.

Continued from the preceding page.

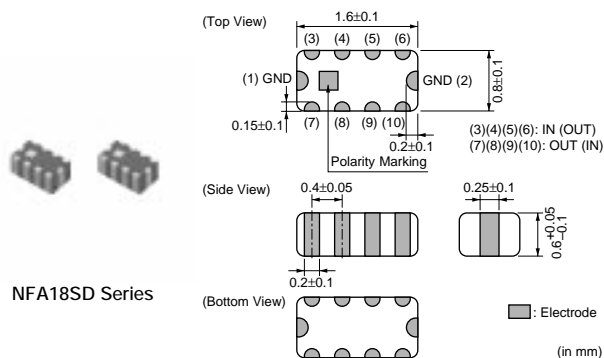

Insertion Loss Characteristics (Main Items)

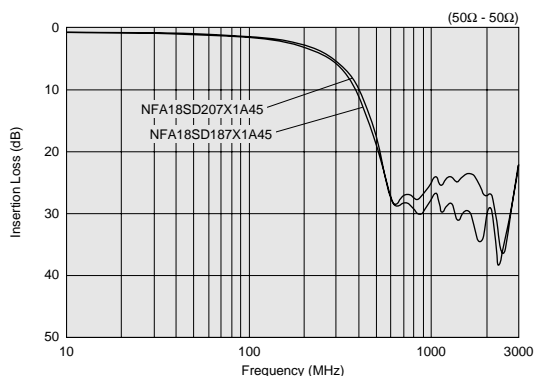

Equivalent Circuit

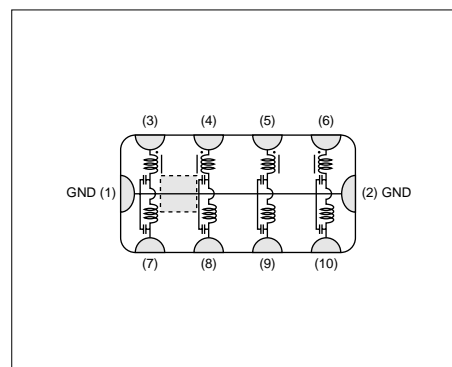

NFA18SL_V Series (0603)

Part Number	Cut-off Frequency (MHz)	Insertion Loss at Cut-off Frequency (dB)	Insertion Loss at 470MHz (min.) (dB)	Insertion Loss at 800MHz (min.) (dB)	Insertion Loss at 900MHz (min.) (dB)	Insertion Loss at 1000MHz (min.) (dB)	Insertion Loss at 1500Hz (min.) (dB)	Insertion Loss at 2000MHz (min.) (dB)	Insulation Resistance (min.) (M ohm)	Rated Voltage (Vdc)	Rated Current (mA)	Withstand Voltage (Vdc)
NFA18SL137V1A45	130	6 max	25	-	25	-	-	-	1000	10	50	30
NFA18SL187V1A45	180	6 max	20	-	20	-	-	-	1000	10	50	30
NFA18SL207V1A45	200	6 max	15	-	15	-	-	-	1000	10	50	30
NFA18SL227V1A45	220	6 max	-	-	30	-	-	30	1000	10	25	30
NFA18SL307V1A45	300	6 max	-	20	20	-	-	-	1000	10	100	30
NFA18SL407V1A45	400	6 max	-	18	18	-	-	-	1000	10	100	30
NFA18SL487V1A45	480	6 max	-	15	15	-	-	-	1000	10	100	30

Number of Circuits: 4

Operating Temperature Range: -40°C to +85°C (NFA18SL137/187/207/227V1A45), -55°C to +125°C (NFA18SL307/407/487V1A45)

NFA18S_X Series (0603)

Part Number	Cut-off Frequency (MHz)	Insertion Loss at Cut-off Frequency (dB)	Insertion Loss at 470MHz (min.) (dB)	Insertion Loss at 800MHz (min.) (dB)	Insertion Loss at 900MHz (min.) (dB)	Insertion Loss at 1000MHz (min.) (dB)	Insertion Loss at 1500Hz (min.) (dB)	Insertion Loss at 2000MHz (min.) (dB)	Insulation Resistance (min.) (M ohm)	Rated Voltage (Vdc)	Rated Current (mA)	Withstand Voltage (Vdc)
NFA18SL506X1A45	50	6 max	-	-	-	25	-	-	1000	10	25	30

Number of Circuits: 4

Operating Temperature Range: -40°C to +85°C

NFA18SD Series (0603)

Part Number	Cut-off Frequency (MHz)	Insertion Loss at Cut-off Frequency (dB)	Insertion Loss at 470MHz (min.) (dB)	Insertion Loss at 800MHz (min.) (dB)	Insertion Loss at 900MHz (min.) (dB)	Insertion Loss at 1000MHz (min.) (dB)	Insertion Loss at 1500Hz (min.) (dB)	Insertion Loss at 2000MHz (min.) (dB)	Insulation Resistance (min.) (M ohm)	Rated Voltage (Vdc)	Rated Current (mA)	Withstand Voltage (Vdc)
NFA18SD187X1A45	180	6 max	-	-	20	-	20	20	1000	10	25	30
NFA18SD207X1A45	200	6 max	-	-	20	-	20	20	1000	10	25	30

Number of Circuits: 4

Operating Temperature Range: -40°C to +85°C

Note • This PDF catalog is downloaded from the website of Murata Manufacturing co., Ltd. Therefore, it's specifications are subject to change or our products in it may be discontinued without advance notice. Please check with our sales representatives or product engineers before ordering.
• This PDF catalog has only typical specifications because there is no space for detailed specifications. Therefore, please approve our product specifications or transact the approval sheet for product specifications before ordering.

EMIFIL® (RC Combined)

Single Circuit Type

● NFR21G Series (0805)

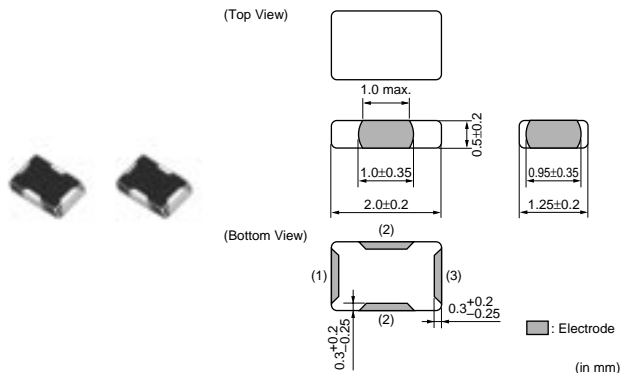

Insertion Loss Characteristics (Main Items)

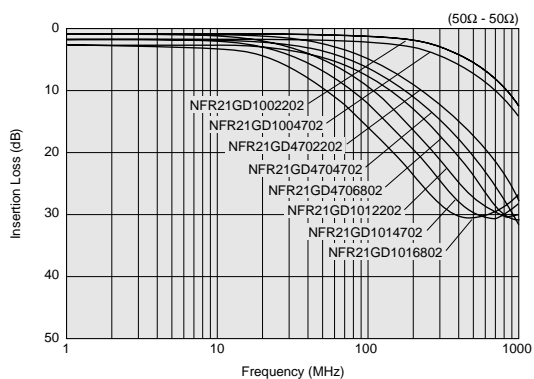

Equivalent Circuit

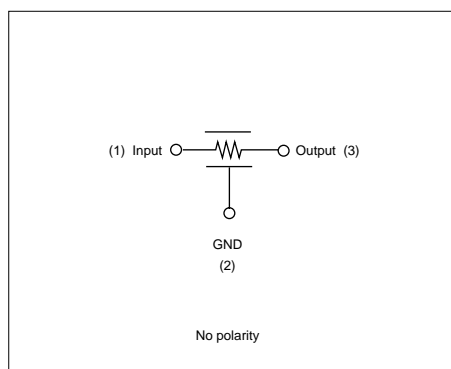

Part Number	Capacitance (pF)	Resistance (ohm)	Rated Current (mA)	Rated Voltage (Vdc)	Insulation Resistance (min.) (M ohm)	Operating Temperature Range
NFR21GD1002202	10 ±20%	22 ±30%	50	50	1000	-40 to +85°C
NFR21GD1004702	10 ±20%	47 ±30%	35	50	1000	-40 to +85°C
NFR21GD4702202	47 ±20%	22 ±30%	50	50	1000	-40 to +85°C
NFR21GD4704702	47 ±20%	47 ±30%	35	50	1000	-40 to +85°C
NFR21GD4706802	47 ±20%	68 ±30%	30	50	1000	-40 to +85°C
NFR21GD4701012	47 ±20%	100 ±30%	25	50	1000	-40 to +85°C
NFR21GD1012202	100 ±20%	22 ±30%	50	50	1000	-40 to +85°C
NFR21GD1014702	100 ±20%	47 ±30%	35	50	1000	-40 to +85°C
NFR21GD1016802	100 ±20%	68 ±30%	30	50	1000	-40 to +85°C
NFR21GD1011012	100 ±20%	100 ±30%	25	50	1000	-40 to +85°C

Number of Circuit: 1

EMIFIL[®] (RC Combined)

Array

● NFA31G Series (1206)

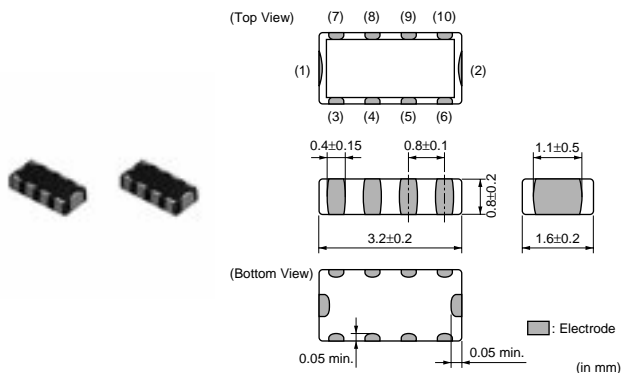

Insertion Loss Characteristics (Main Items)

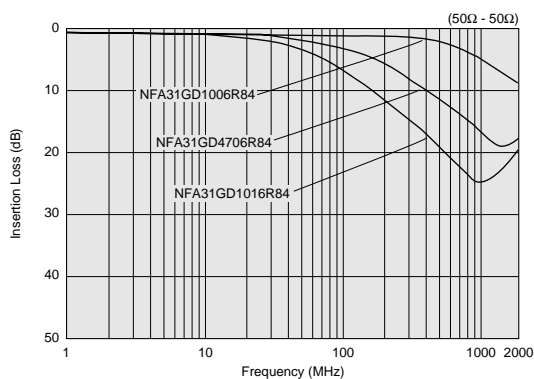

Equivalent Circuit

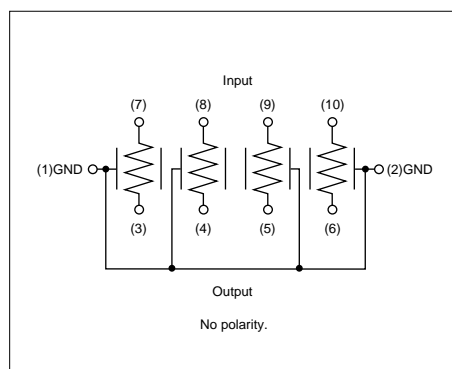

Part Number	Capacitance (pF)	Resistance (ohm)	Rated Current (mA)	Rated Voltage (Vdc)	Insulation Resistance (min.) (M ohm)	Operating Temperature Range
NFA31GD1006R84	10 ±20%	6.8 ±40%	50	6	1000	-40 to +85°C
NFA31GD1004704	10 ±20%	47 ±30%	20	6	1000	-40 to +85°C
NFA31GD1001014	10 ±20%	100 ±30%	15	6	1000	-40 to +85°C
NFA31GD4706R84	47 ±20%	6.8 ±40%	50	6	1000	-40 to +85°C
NFA31GD4703304	47 ±20%	33 ±30%	20	6	1000	-40 to +85°C
NFA31GD4704704	47 ±20%	47 ±30%	20	6	1000	-40 to +85°C
NFA31GD4701014	47 ±20%	100 ±30%	15	6	1000	-40 to +85°C
NFA31GD1016R84	100 ±20%	6.8 ±40%	50	6	1000	-40 to +85°C
NFA31GD1014704	100 ±20%	47 ±30%	20	6	1000	-40 to +85°C
NFA31GD1011014	100 ±20%	100 ±30%	15	6	1000	-40 to +85°C

Number of Circuit: 4

△Note • This PDF catalog is downloaded from the website of Murata Manufacturing co., ltd. Therefore, it's specifications are subject to change or our products in it may be discontinued without advance notice. Please check with our sales representatives or product engineers before ordering.
• This PDF catalog has only typical specifications because there is no space for detailed specifications. Therefore, please approve our product specifications or transact the approval sheet for product specifications before ordering.

Common Mode Choke Coil

Film Type

Equivalent Circuit

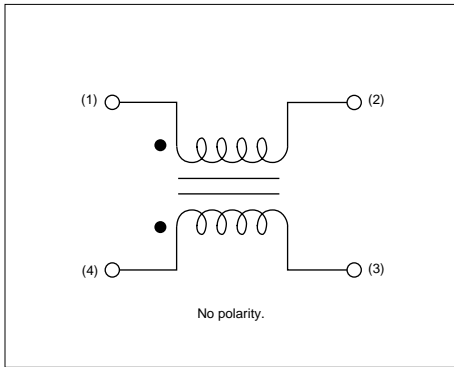

Noise Suppression Products/EMI Suppression Filters

2

● DLP0NS Series (03025)

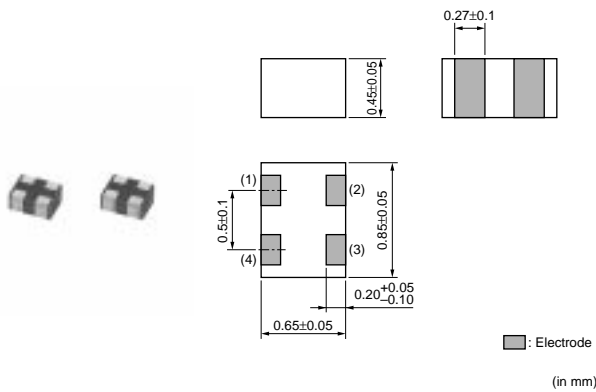

Impedance-Frequency Characteristics (Main Items)

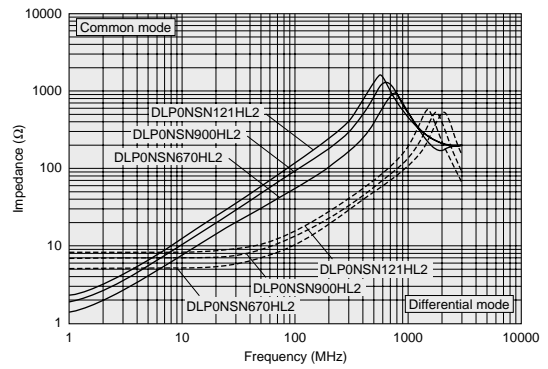

Part Number	Common Mode Impedance (at 100MHz/20 degree C) (ohm)	Rated Current (mA)	Rated Voltage (Vdc)	Insulation Resistance (min.) (M ohm)	Withstand Voltage (Vdc)	DC Resistance (ohm)
DLP0NSN670HL2	67 ±20%	110	5	100	12.5	2.4 ±25%
DLP0NSN900HL2	90 ±20%	100	5	100	12.5	3.0 ±25%
DLP0NSN121HL2	120 ±20%	90	5	100	12.5	3.8 ±25%

Operating Temperature Range: -40 to +85°C

● DLP11S Series (0504)

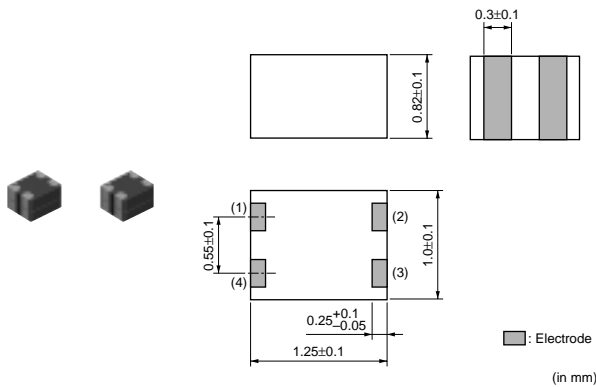

Continued on the following page.

Continued from the preceding page.

Impedance-Frequency Characteristics (Main Items)

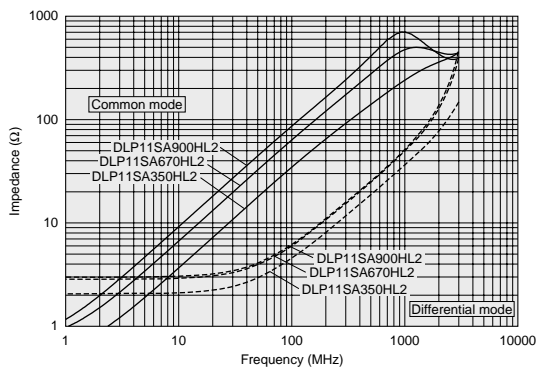

Impedance-Frequency Characteristics (Main Items)

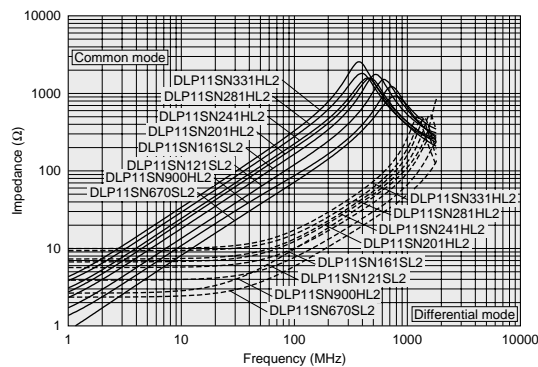

Part Number	Common Mode Impedance (at 100MHz/20 degree C) (ohm)	Rated Current (mA)	Rated Voltage (Vdc)	Insulation Resistance (min.) (M ohm)	Withstand Voltage (Vdc)	DC Resistance (ohm)
DLP11SN670SL2	67 ±20%	180	5	100	12.5	1.3 ±25%
DLP11SN121SL2	120 ±20%	140	5	100	12.5	2.0 ±25%
DLP11SN161SL2	160 ±20%	120	5	100	12.5	2.7 ±25%
DLP11SN900HL2	90 ±20%	150	5	100	12.5	1.5 ±25%
DLP11SN201HL2	200 ±20%	110	5	100	12.5	3.1 ±25%
DLP11SN241HL2	240 ±20%	100	5	100	12.5	3.5 ±25%
DLP11SN281HL2	280 ±20%	90	5	100	12.5	4.2 ±25%
DLP11SN331HL2	330 ±20%	80	5	100	12.5	4.9 ±25%
DLP11SA350HL2	35 ±20%	170	5	100	12.5	0.9 ±25%
DLP11SA670HL2	67 ±20%	150	5	100	12.5	1.2 ±25%
DLP11SA900HL2	90 ±20%	150	5	100	12.5	1.4 ±25%

Operating Temperature Range: -40 to +85°C

● DLP31S Series (1206)

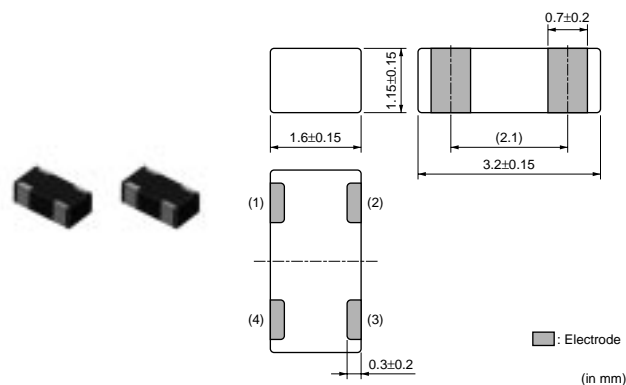

Impedance-Frequency Characteristics (Main Items)

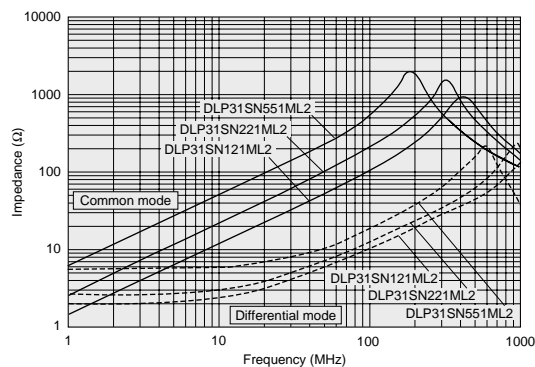

Part Number	Common Mode Impedance (at 100MHz/20 degree C) (ohm)	Rated Current (mA)	Rated Voltage (Vdc)	Insulation Resistance (min.) (M ohm)	Withstand Voltage (Vdc)	DC Resistance (ohm)
DLP31SN121ML2	120 ±20%	100	16	100	40	2.0 max.
DLP31SN221ML2	220 ±20%	100	16	100	40	2.5 max.
DLP31SN551ML2	550 ±20%	100	16	100	40	3.6 max.

Operating Temperature Range: -40 to +85°C

△Note • This PDF catalog is downloaded from the website of Murata Manufacturing co., ltd. Therefore, it's specifications are subject to change or our products in it may be discontinued without advance notice. Please check with our sales representatives or product engineers before ordering.
 • This PDF catalog has only typical specifications because there is no space for detailed specifications. Therefore, please approve our product specifications or transact the approval sheet for product specifications before ordering.

Common Mode Choke Coil

Film Type (Array)

Equivalent Circuit

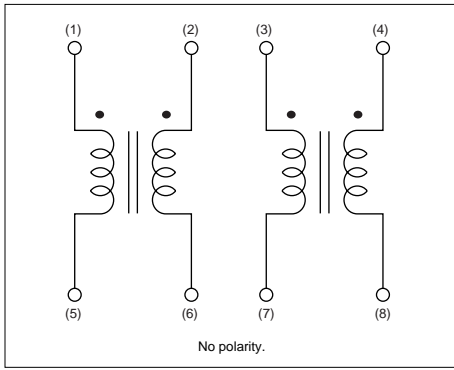

Noise Suppression Products/EMI Suppression Filters

2

● DLP2AD Series (0804)

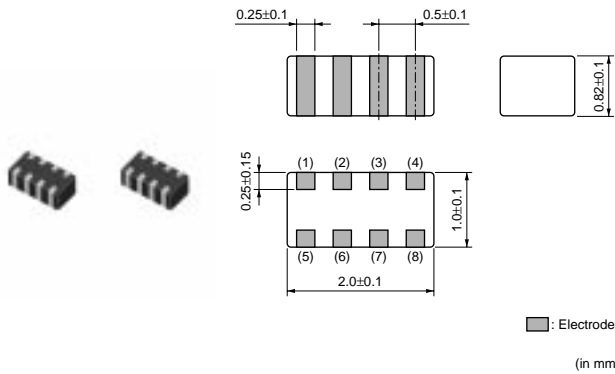

Impedance-Frequency Characteristics (Main Items)

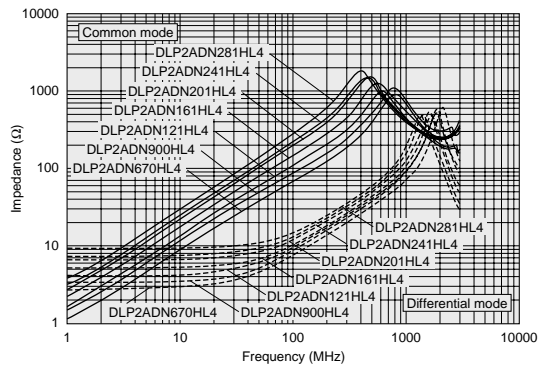

Part Number	Common Mode Impedance (at 100MHz/20 degree C) (ohm)	Rated Current (mA)	Rated Voltage (Vdc)	Insulation Resistance (min.) (M ohm)	Withstand Voltage (Vdc)	DC Resistance (ohm)
DLP2ADN670HL4	67 ±20%	140	5	100	12.5	1.3 ±25%
DLP2ADN900HL4	90 ±20%	130	5	100	12.5	1.7 ±25%
DLP2ADN121HL4	120 ±20%	120	5	100	12.5	2.0 ±25%
DLP2ADN161HL4	160 ±20%	100	5	100	12.5	2.5 ±25%
DLP2ADN201HL4	200 ±20%	90	5	100	12.5	3.2 ±25%
DLP2ADN241HL4	240 ±20%	80	5	100	12.5	3.8 ±25%
DLP2ADN281HL4	280 ±20%	80	5	100	12.5	4.6 ±25%

Operating Temperature Range: -40 to +85°C
Number of Circuit: 2

● DLP31D Series (1206)

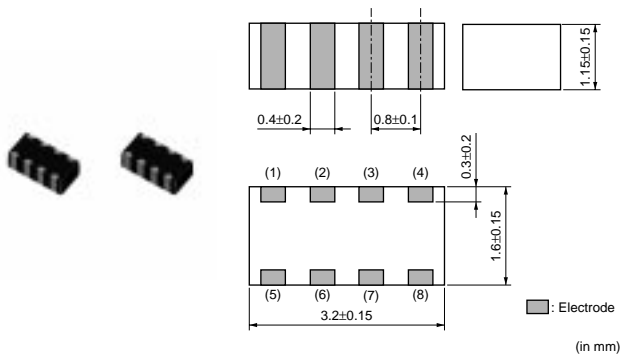

Impedance-Frequency Characteristics (Main Items)

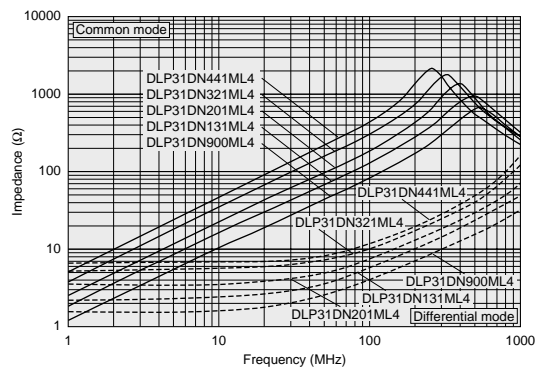

Part Number	Common Mode Impedance (at 100MHz/20 degree C) (ohm)	Rated Current (mA)	Rated Voltage (Vdc)	Insulation Resistance (min.) (M ohm)	Withstand Voltage (Vdc)	DC Resistance (ohm)
DLP31DN900ML4	90 ±20%	160	10	100	25	1.1 max.
DLP31DN131ML4	130 ±20%	120	10	100	25	1.6 max.
DLP31DN201ML4	200 ±20%	100	10	100	25	2.2 max.
DLP31DN321ML4	320 ±20%	80	10	100	25	3.5 max.
DLP31DN441ML4	440 ±20%	70	10	100	25	4.3 max.

Operating Temperature Range: -40 to +85°C

Number of Circuit: 2

Common Mode Choke Coil

Multilayer Type

● DLM11G Series

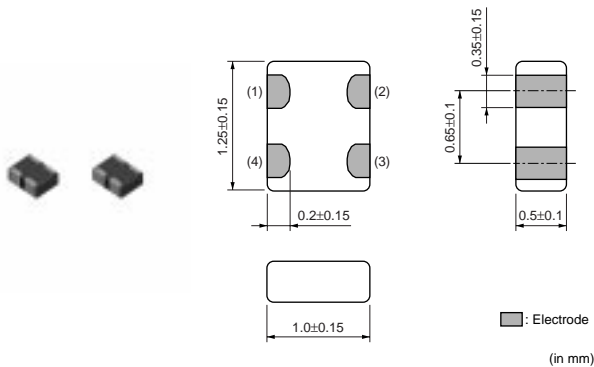

Impedance-Frequency Characteristics (Main Items)

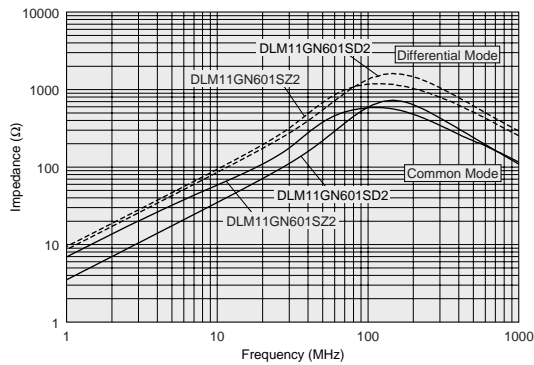

Equivalent Circuit

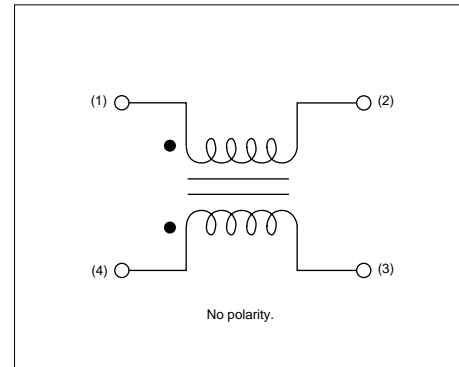

Part Number	Common Mode Impedance (at 100MHz/20 degree C) (ohm)	Rated Current (mA)	Rated Voltage (Vdc)	Insulation Resistance (min.) (M ohm)	Withstand Voltage (Vdc)	DC Resistance (ohm)
DLM11GN601SD2	600 ±25%	100	5	100	25	0.8 max.
DLM11GN601SZ2	600 ±25%	100	5	100	25	0.8 max.

Operating Temperature Range: -40 to +85°C

⚠ Note • This PDF catalog is downloaded from the website of Murata Manufacturing co., ltd. Therefore, it's specifications are subject to change or our products in it may be discontinued without advance notice. Please check with our sales representatives or product engineers before ordering.
 • This PDF catalog has only typical specifications because there is no space for detailed specifications. Therefore, please approve our product specifications or transact the approval sheet for product specifications before ordering.

● DLM2HG Series

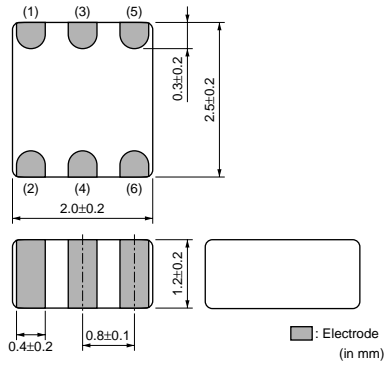

Impedance-Frequency Characteristics (Main Items)

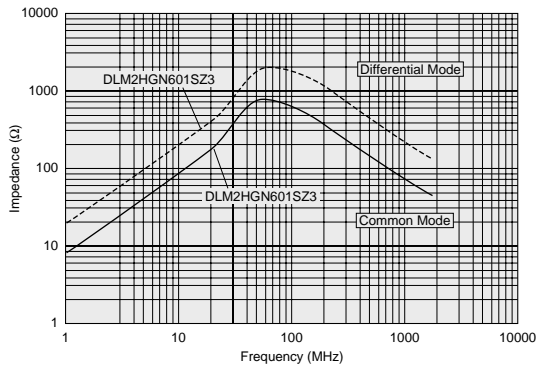

Equivalent Circuit

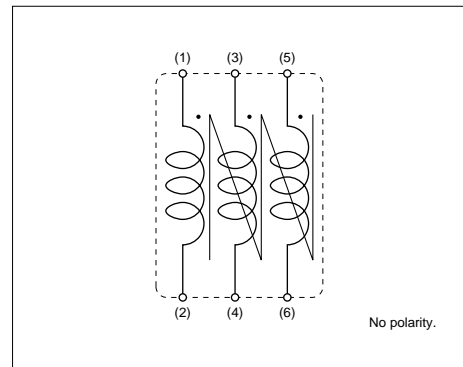

Part Number	Common Mode Impedance (at 100MHz/20 degree C) (ohm)	Rated Current (mA)	Rated Voltage (Vdc)	Insulation Resistance (min.) (M ohm)	Withstand Voltage (Vdc)	DC Resistance (ohm)
DLM2HGN601SZ3	600 ±25%	100	16	100	100	0.40 max.

Operating Temperature Range: -40 to +85°C

Common Mode Choke Coil

Wire Wound Type

Equivalent Circuit

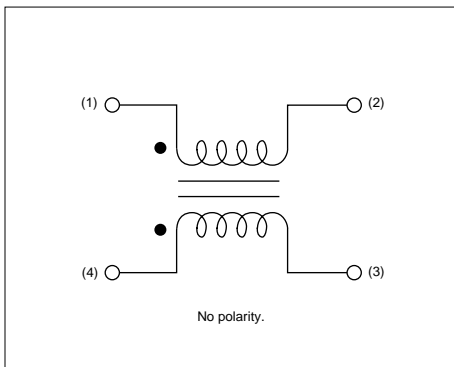

⚠️Note • This PDF catalog is downloaded from the website of Murata Manufacturing co., Ltd. Therefore, it's specifications are subject to change or our products in it may be discontinued without advance notice. Please check with our sales representatives or product engineers before ordering.
• This PDF catalog has only typical specifications because there is no space for detailed specifications. Therefore, please approve our product specifications or transact the approval sheet for product specifications before ordering.

DLW21H Series (0805)

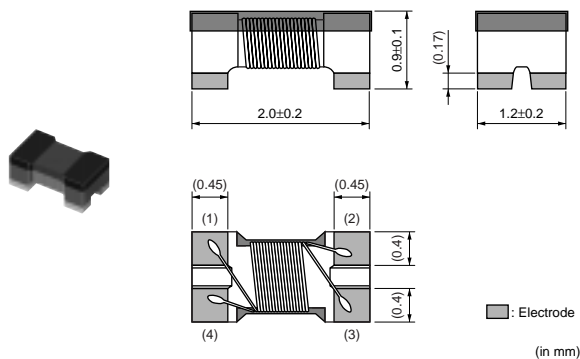

Impedance-Frequency Characteristics (Main Items)

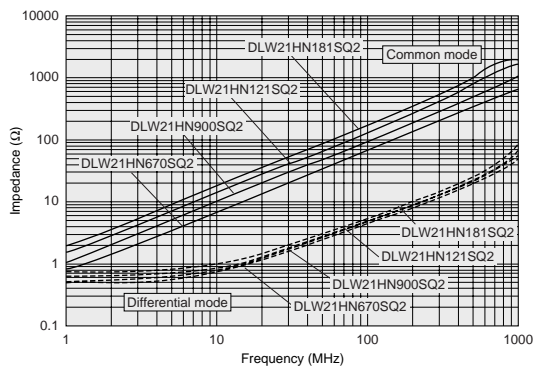

Part Number	Common Mode Impedance (at 100MHz/20 degree C) (ohm)	Rated Current (mA)	Rated Voltage (Vdc)	Insulation Resistance (min.) (M ohm)	Withstand Voltage (Vdc)	DC Resistance (ohm)
DLW21HN670SQ2	67 ±25%	330	50	10	125	0.35 max.
DLW21HN900SQ2	90 ±25%	330	50	10	125	0.35 max.
DLW21HN121SQ2	120 ±25%	280	50	10	125	0.45 max.
DLW21HN181SQ2	180 ±25%	250	50	10	125	0.50 max.

Operating Temperature Range: -40 to +85°C

DLW21S Series (0805)

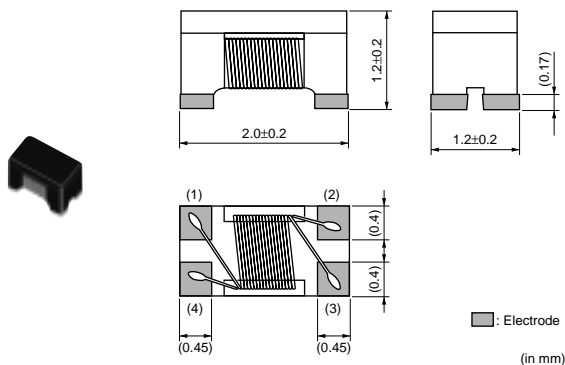

Impedance-Frequency Characteristics (Main Items)

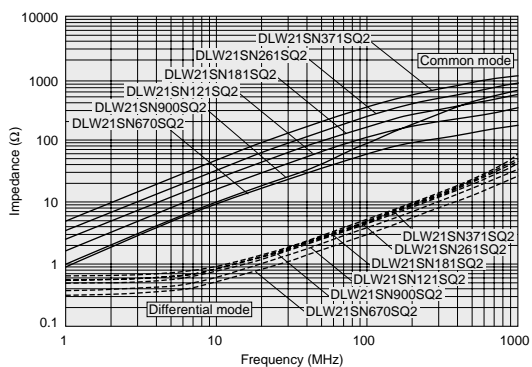

Impedance-Frequency Characteristics (Main Items)

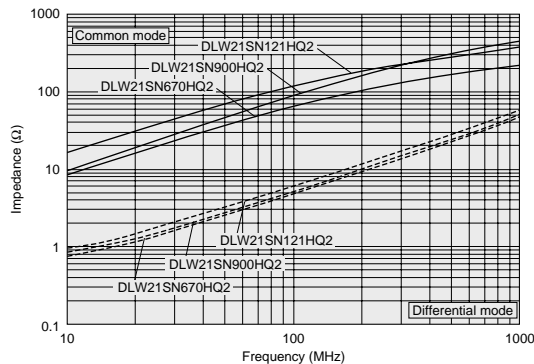

Part Number	Common Mode Impedance (at 100MHz/20 degree C) (ohm)	Rated Current (mA)	Rated Voltage (Vdc)	Insulation Resistance (min.) (M ohm)	Withstand Voltage (Vdc)	DC Resistance (ohm)
DLW21SN670SQ2	67 ±25%	400	50	10	125	0.25 max.
DLW21SN900SQ2	90 ±25%	330	50	10	125	0.35 max.
DLW21SN121SQ2	120 ±25%	370	50	10	125	0.30 max.
DLW21SN181SQ2	180 ±25%	330	50	10	125	0.35 max.
DLW21SN261SQ2	260 ±25%	300	50	10	125	0.40 max.
DLW21SN371SQ2	370 ±25%	280	50	10	125	0.45 max.

Continued on the following page.

⚠ Note • This PDF catalog is downloaded from the website of Murata Manufacturing co., ltd. Therefore, it's specifications are subject to change or our products in it may be discontinued without advance notice. Please check with our sales representatives or product engineers before ordering.
 • This PDF catalog has only typical specifications because there is no space for detailed specifications. Therefore, please approve our product specifications or transact the approval sheet for product specifications before ordering.

Continued from the preceding page.

Part Number	Common Mode Impedance (at 100MHz/20 degree C) (ohm)	Rated Current (mA)	Rated Voltage (Vdc)	Insulation Resistance (min.) (M ohm)	Withstand Voltage (Vdc)	DC Resistance (ohm)
DLW21SN670HQ2	67 ±25%	320	20	10	50	0.31 max.
DLW21SN900HQ2	90 ±25%	280	20	10	50	0.41 max.
DLW21SN121HQ2	120 ±25%	280	20	10	50	0.41 max.
DLW21SR670HQ2	67 ±25%	400	20	10	50	0.25 max.

Operating Temperature Range: -40 to +85°C

● DLW31S Series (1206)

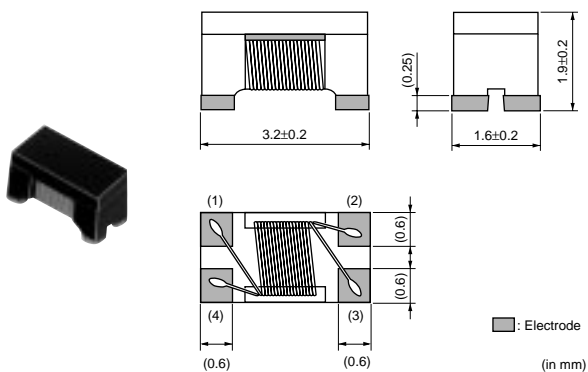

Impedance-Frequency Characteristics (Main Items)

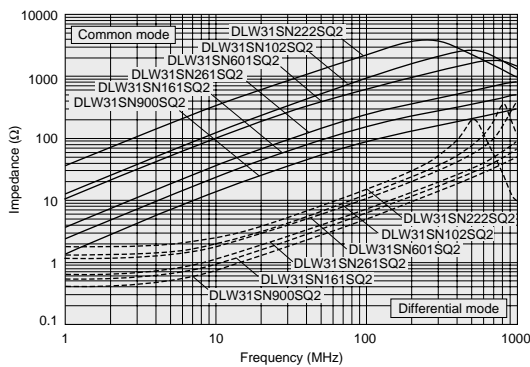

Part Number	Common Mode Impedance (at 100MHz/20 degree C) (ohm)	Rated Current (mA)	Rated Voltage (Vdc)	Insulation Resistance (min.) (M ohm)	Withstand Voltage (Vdc)	DC Resistance (ohm)
DLW31SN900SQ2	90 ±25%	370	50	10	125	0.3 max.
DLW31SN161SQ2	160 ±25%	340	50	10	125	0.4 max.
DLW31SN261SQ2	260 ±25%	310	50	10	125	0.5 max.
DLW31SN601SQ2	600 ±25%	260	50	10	125	0.8 max.
DLW31SN102SQ2	1000 ±25%	230	50	10	125	1.0 max.
DLW31SN222SQ2	2200 ±25%	200	50	10	125	1.2 max.

Operating Temperature Range: -40 to +85°C

Common Mode Choke Coil

Wire Wound Type for Large Current

Equivalent Circuit

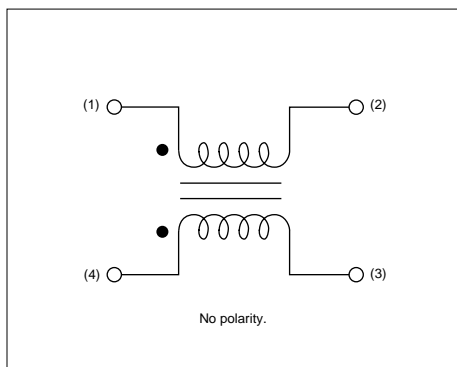

Note • This PDF catalog is downloaded from the website of Murata Manufacturing co., Ltd. Therefore, it's specifications are subject to change or our products in it may be discontinued without advance notice. Please check with our sales representatives or product engineers before ordering.
• This PDF catalog has only typical specifications because there is no space for detailed specifications. Therefore, please approve our product specifications or transact the approval sheet for product specifications before ordering.

DLW5AH (2014) /DLW5BS (2020) /DLW5BT (2020) Series

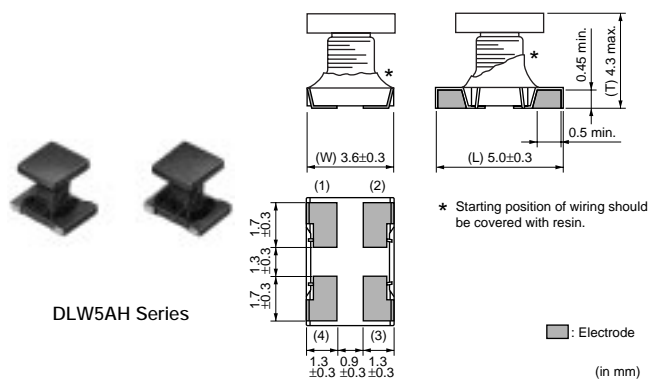

Impedance-Frequency Characteristics (Main Items)

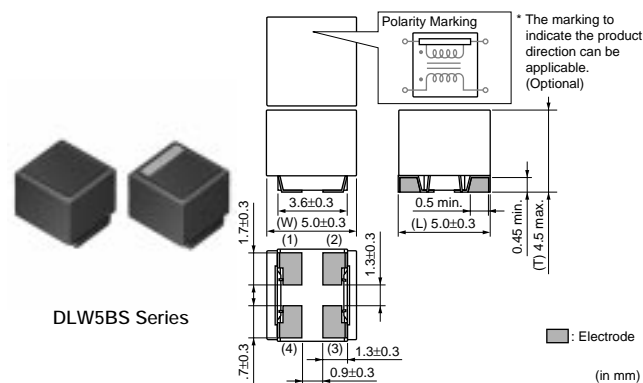
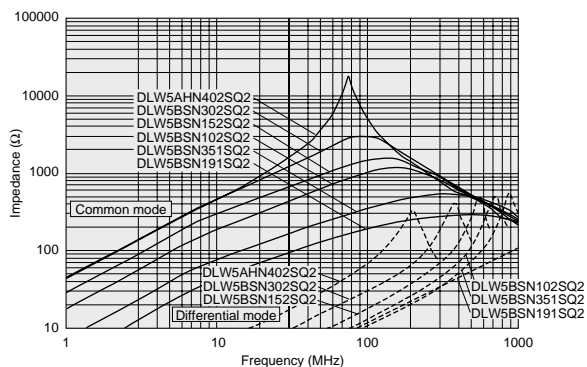

Impedance-Frequency Characteristics (Main Items)

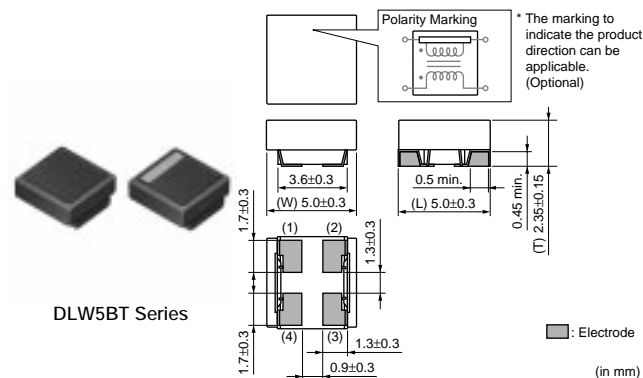
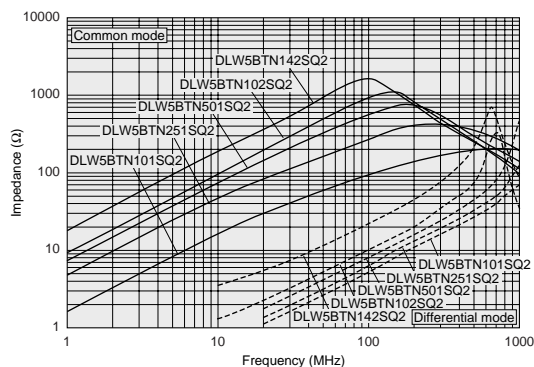

Part Number	Common Mode Impedance (at 100MHz/20 degree C) (ohm)	Rated Current (mA)	Rated Voltage (Vdc)	Insulation Resistance (min.) (M ohm)	Withstand Voltage (Vdc)	DC Resistance (ohm)
DLW5AHN402SQ2	4000 (Typ.)	200	50	10	125	3.0 max.
DLW5BSN191SQ2	190 (Typ.)	5000	50	10	125	0.02 max.
DLW5BSN351SQ2	350 (Typ.)	2000	50	10	125	0.04 max.
DLW5BSN102SQ2	1000 (Typ.)	1500	50	10	125	0.06 max.
DLW5BSN152SQ2	1500 (Typ.)	1000	50	10	125	0.1 max.
DLW5BSN302SQ2	3000 (Typ.)	500	50	10	125	0.3 max.
DLW5BTN101SQ2	100 (Typ.)	6000	50	10	125	0.009 ±40%
DLW5BTN251SQ2	250 (Typ.)	5000	50	10	125	0.014 ±40%
DLW5BTN501SQ2	500 (Typ.)	4000	50	10	125	0.019 ±40%
DLW5BTN102SQ2	1000 (Typ.)	2000	50	10	125	0.024 ±40%
DLW5BTN142SQ2	1400 (Typ.)	1500	50	10	125	0.040 ±40%

Operating Temperature Range: -25 to +85°C

△Note • This PDF catalog is downloaded from the website of Murata Manufacturing co., ltd. Therefore, it's specifications are subject to change or our products in it may be discontinued without advance notice. Please check with our sales representatives or product engineers before ordering.
• This PDF catalog has only typical specifications because there is no space for detailed specifications. Therefore, please approve our product specifications or transact the approval sheet for product specifications before ordering.

Leaded EMIFIL[®] (Inductor Type)

Equivalent Circuit

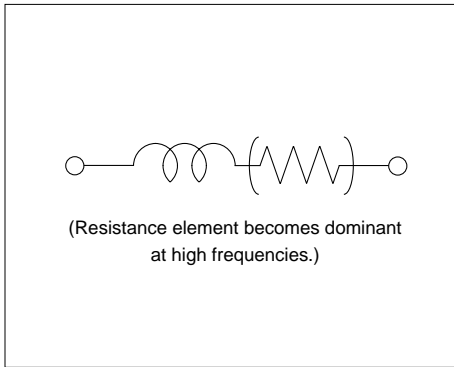

2 Noise Suppression Products/EMI Suppression Filters

● Ferrite Beads Inductors BL01/BL02/BL03 Series

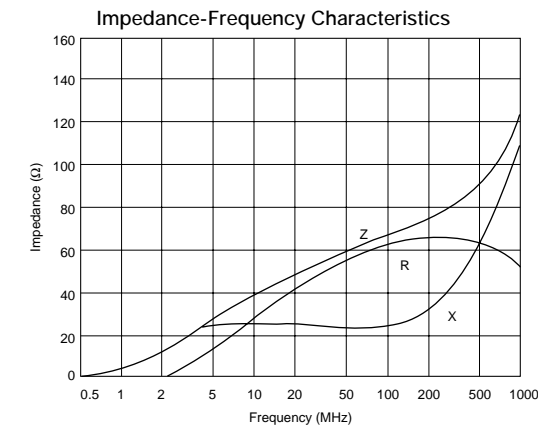
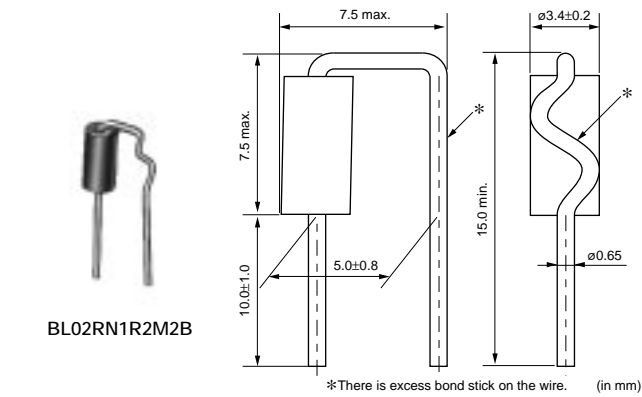
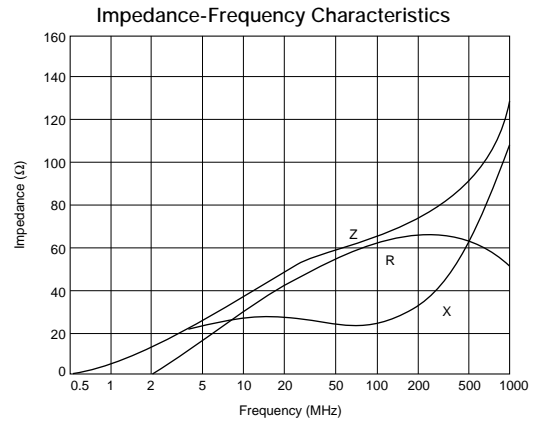
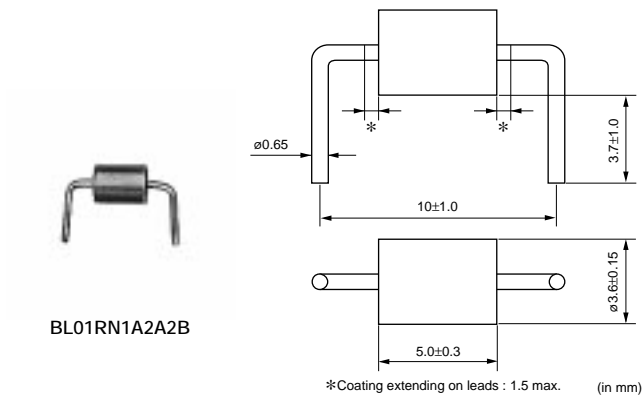
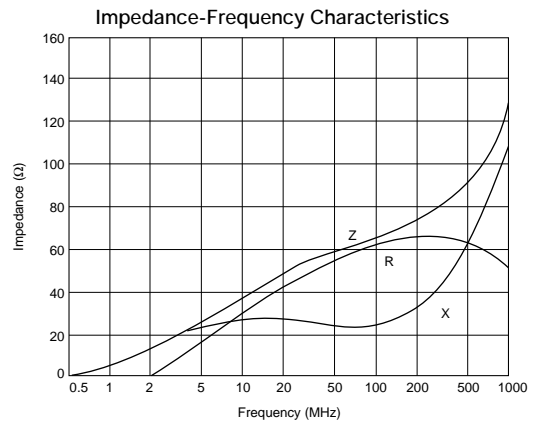
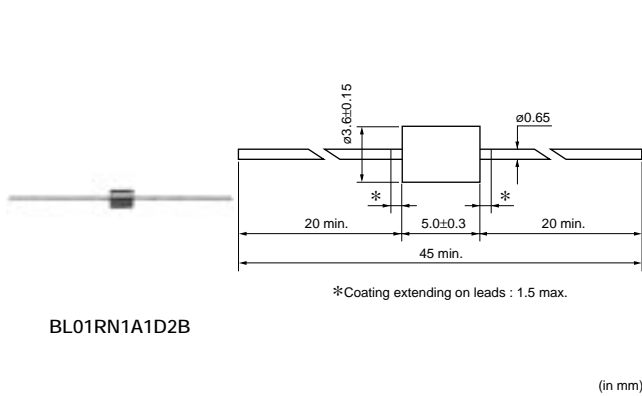

Continued on the following page.

Continued from the preceding page.

BL02RN1R3J2B

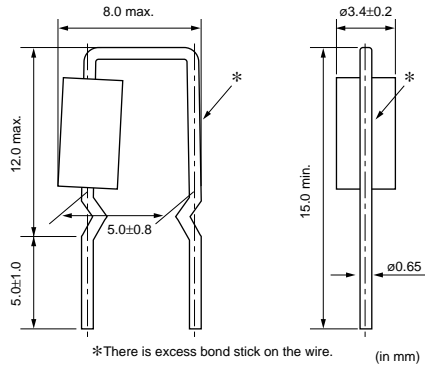

Impedance-Frequency Characteristics

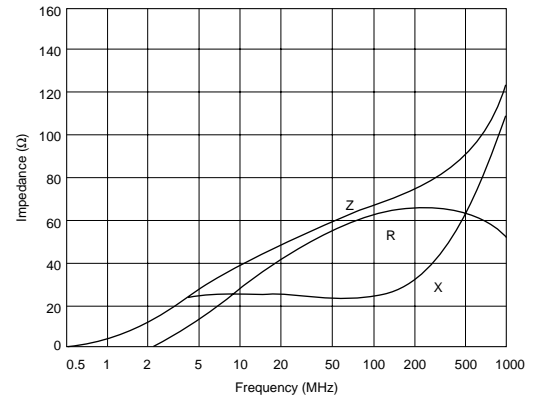

BL02RN2R1M2B

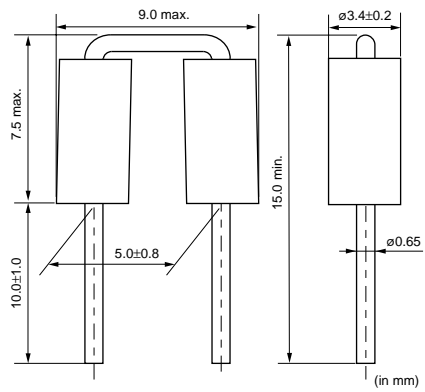

Impedance-Frequency Characteristics

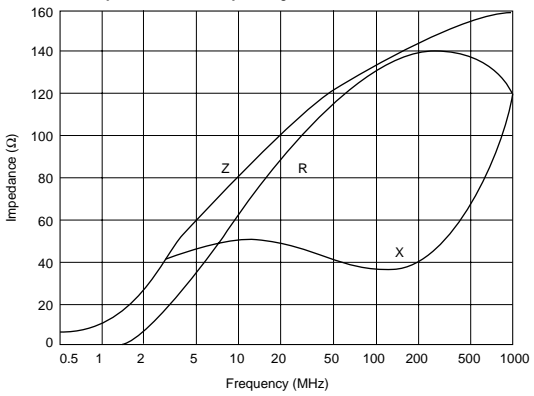

BL02RN2R3J2B

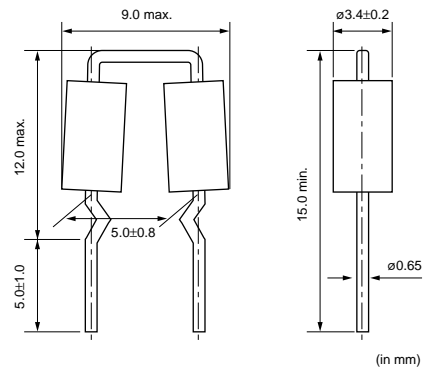

Impedance-Frequency Characteristics

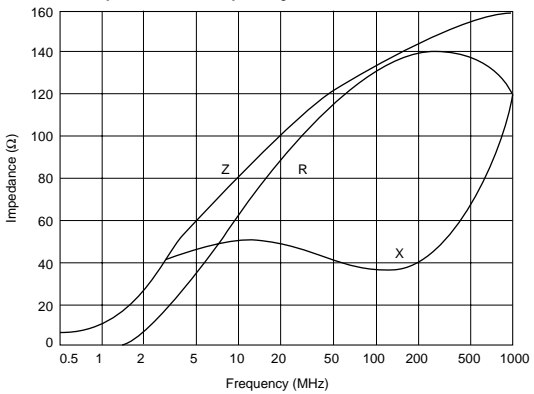

BL03RN2R1M1B

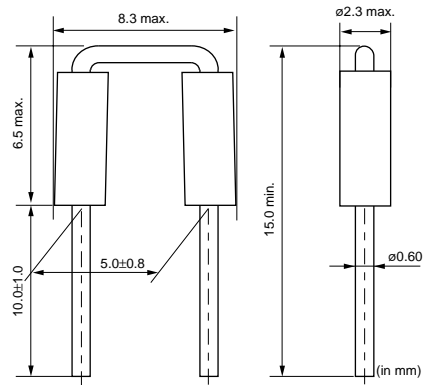

Impedance-Frequency Characteristics

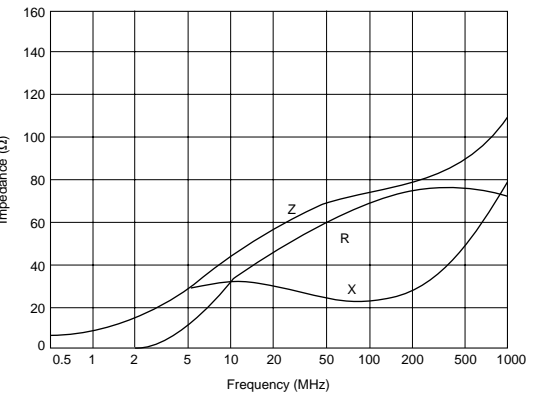

△Note • This PDF catalog is downloaded from the website of Murata Manufacturing co., ltd. Therefore, it's specifications are subject to change or our products in it may be discontinued without advance notice. Please check with our sales representatives or product engineers before ordering.
• This PDF catalog has only typical specifications because there is no space for detailed specifications. Therefore, please approve our product specifications or transact the approval sheet for product specifications before ordering.

Part Number	Rated Current (A)	Operating Temperature Range
BL01RN1A1D2B	7	-40 to +85°C
BL01RN1A1E1A	6	-40 to +85°C
BL01RN1A1F1J	6	-40 to +85°C
BL01RN1A2A2B	7	-40 to +85°C
BL02RN1R2M2B	7	-40 to +85°C
BL02RN1R2N1A	6	-40 to +85°C
BL02RN1R2P1A	6	-40 to +85°C
BL02RN1R2Q1A	6	-40 to +85°C
BL02RN1R3J2B	7	-40 to +85°C
BL02RN1R3N1A	6	-40 to +85°C
BL02RN2R1M2B	7	-40 to +85°C
BL02RN2R1N1A	6	-40 to +85°C
BL02RN2R1P1A	6	-40 to +85°C
BL02RN2R1Q1A	6	-40 to +85°C
BL02RN2R3J2B	7	-40 to +85°C
BL02RN2R3N1A	6	-40 to +85°C
BL03RN2R1M1B	6	-40 to +85°C
BL03RN2R1N1A	6	-40 to +85°C
BL03RN2R1P1A	6	-40 to +85°C
BL03RN2R1Q1A	6	-40 to +85°C

Leaded EMIFIL[®] (Capacitor Type)

Small Type

● DSN6 Series

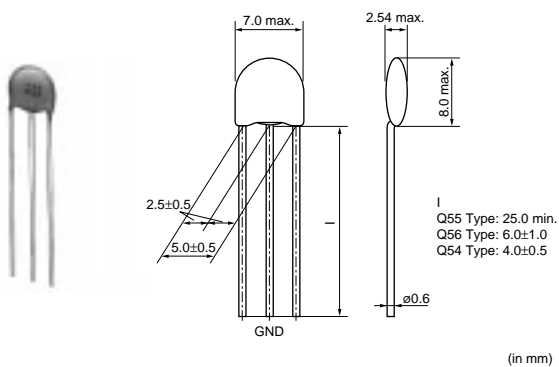

Insertion Loss Characteristics (Main Items)

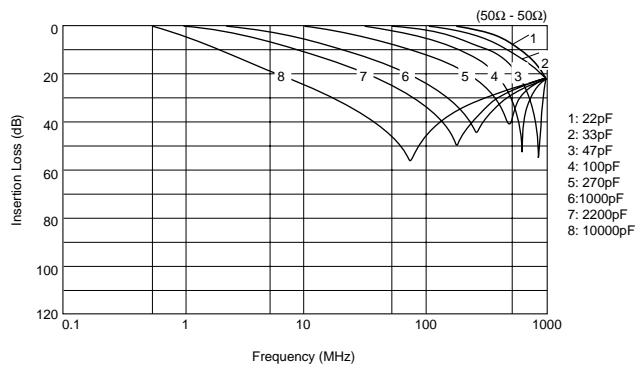

Equivalent Circuit

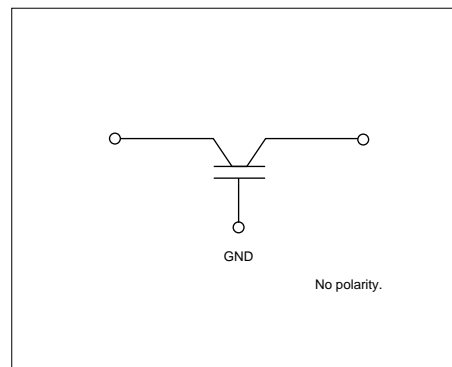

Part Number	Capacitance (pF)	Rated Voltage (Vdc)	Rated Current (A)	Operating Temperature Range
DSN6NC51H220	22 ±20%	50	6	-25 to +85°C
DSN6NC51H330	33 ±20%	50	6	-25 to +85°C
DSN6NC51H470	47 ±20%	50	6	-25 to +85°C
DSN6NC51H101	100 ±20%	50	6	-25 to +85°C
DSN6NC51H271	270 ±20%	50	6	-25 to +85°C
DSN6NC51H102	1000 ±20%	50	6	-25 to +85°C
DSN6NC51H222	2200 ±20%	50	6	-25 to +85°C
DSN6NZ81H103	10000 80/-20%	50	6	-25 to +85°C

Please refer to Part Numbering instruction for type and length of lead.

● Built-in Ferrite Beads DSS6 Series Straight Type

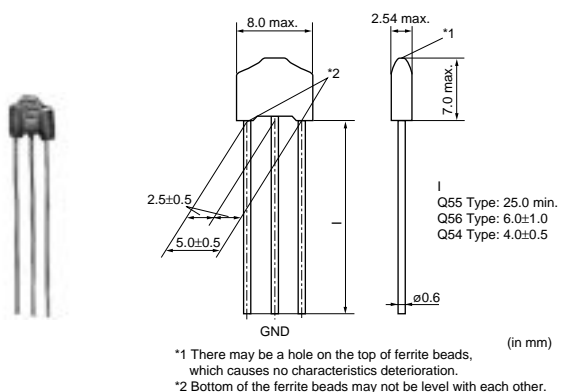

Insertion Loss Characteristics (Main Items)

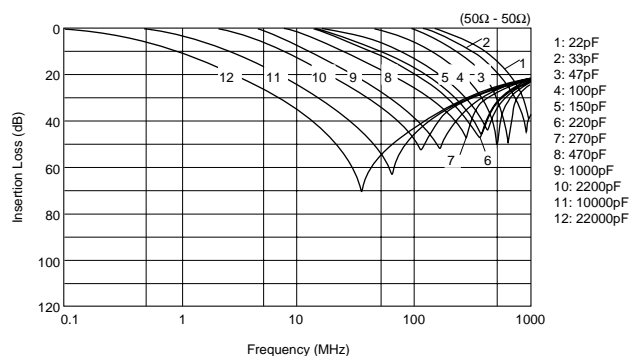

Equivalent Circuit

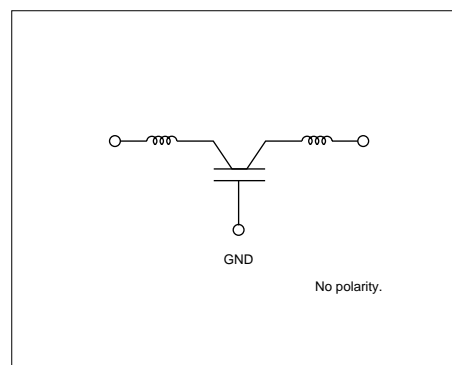

Part Number	Capacitance (pF)	Rated Voltage (Vdc)	Rated Current (A)	Operating Temperature Range
DSS6NC52A220	22 ±20%	100	6	-25 to +85°C
DSS6NC52A330	33 ±20%	100	6	-25 to +85°C
DSS6NC52A470	47 ±20%	100	6	-25 to +85°C
DSS6NC52A101	100 ±20%	100	6	-25 to +85°C
DSS6NC52A151	150 ±20%	100	6	-25 to +85°C
DSS6NC52A221	220 ±20%	100	6	-25 to +85°C
DSS6NC52A271	270 ±20%	100	6	-25 to +85°C
DSS6NC52A471	470 ±20%	100	6	-25 to +85°C
DSS6NC52A102	1000 ±20%	100	6	-25 to +85°C
DSS6NE52A222	2200 80/-20%	100	6	-25 to +85°C
DSS6NZ82A103	10000 ±30%	100	6	-25 to +85°C
DSS6NF31C223	22000 80/-20%	16	6	-25 to +85°C

Please refer to Part Numbering instruction for type and length of lead.

△Note • This PDF catalog is downloaded from the website of Murata Manufacturing co., ltd. Therefore, it's specifications are subject to change or our products in it may be discontinued without advance notice. Please check with our sales representatives or product engineers before ordering.
• This PDF catalog has only typical specifications because there is no space for detailed specifications. Therefore, please approve our product specifications or transact the approval sheet for product specifications before ordering.

● Built-in Ferrite Beads DSS6 Series Incrimp Type

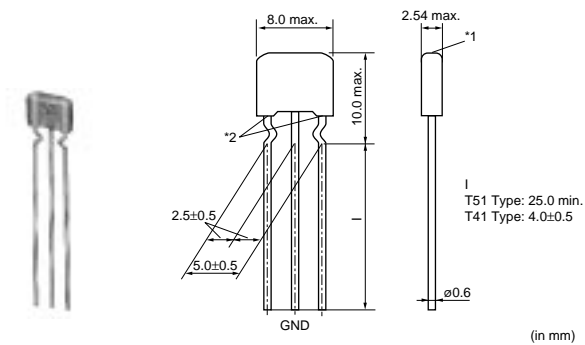

(in mm)
*1 There may be a hole on the top of ferrite beads, which causes no characteristics deterioration.
*2 Bottom of the ferrite beads may not be level with each other.

Insertion Loss Characteristics (Main Items)

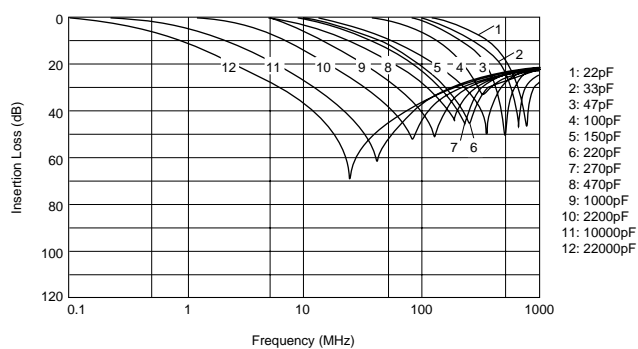

Equivalent Circuit

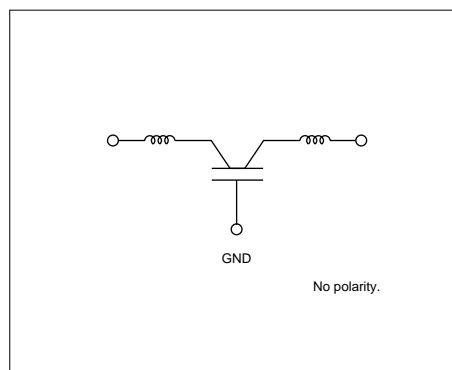

Part Number	Capacitance (pF)	Rated Voltage (Vdc)	Rated Current (A)	Operating Temperature Range
DSS6NC52A220	22 ±20%	100	6	-25 to +85°C
DSS6NC52A330	33 ±20%	100	6	-25 to +85°C
DSS6NC52A470	47 ±20%	100	6	-25 to +85°C
DSS6NC52A101	100 ±20%	100	6	-25 to +85°C
DSS6NC52A151	150 ±20%	100	6	-25 to +85°C
DSS6NC52A221	220 ±20%	100	6	-25 to +85°C
DSS6NC52A271	270 ±20%	100	6	-25 to +85°C
DSS6NC52A471	470 ±20%	100	6	-25 to +85°C
DSS6NC52A102	1000 ±20%	100	6	-25 to +85°C
DSS6NE52A222	2200 80/-20%	100	6	-25 to +85°C
DSS6NZ82A103	10000 ±30%	100	6	-25 to +85°C
DSS6NF31C223	22000 80/-20%	16	6	-25 to +85°C

Please refer to Part Numbering instruction for type and length of lead.

Leaded EMIFIL[®] (Capacitor Type)

Standard Type

● DSN9 Series

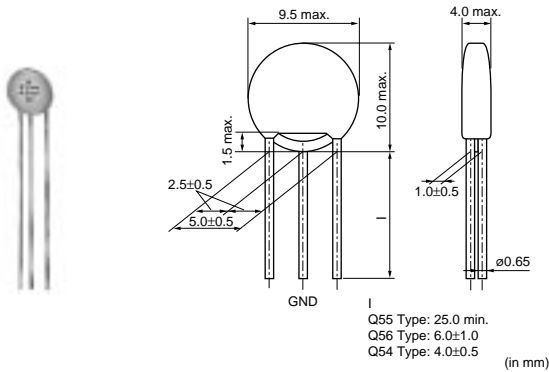

Insertion Loss Characteristics (Main Items)

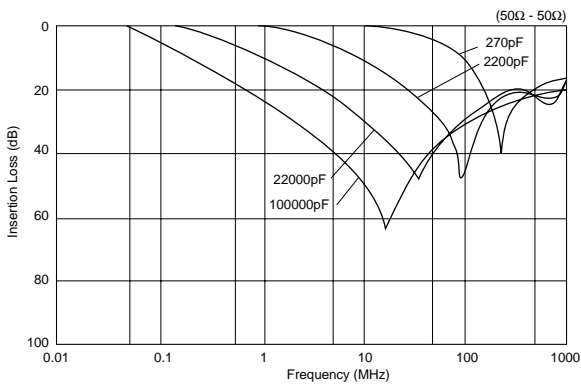

Equivalent Circuit

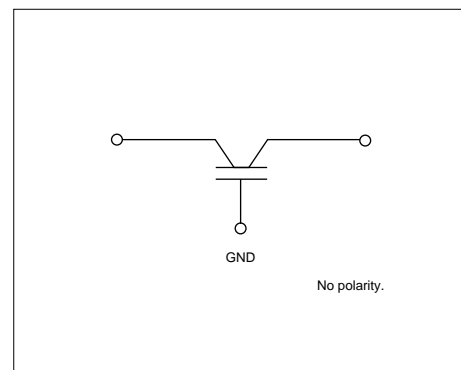

Part Number	Capacitance (pF)	Rated Voltage (Vdc)	Rated Current (A)	Operating Temperature Range
DSN9NC52A271	270 ±20%	100	7	-25 to +85°C
DSN9NC52A222	2200 ±20%	100	7	-25 to +85°C
DSN9NC51H223	22000 50/-20%	50	7	-25 to +85°C
DSN9NC51C104	100000 ±20%	16	7	-25 to +85°C

Rated current is 6A for taping type and its lead diameter is phi 0.6mm and three terminal in line arrangement.

Rated current is 7A for bulk type.

Please refer to Part Numbering instruction for type and length of lead.

● Built-in Ferrite Beads DSS9 Series

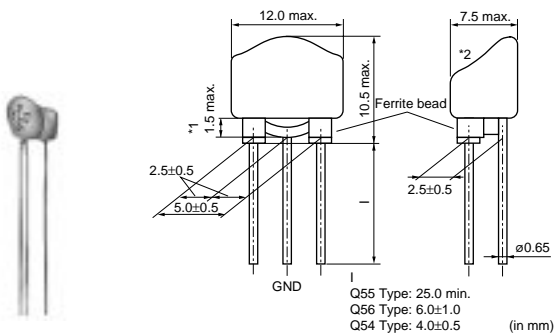

*1 Coating extending on leads does not exceed the tangent line. Exposed electrode, if any, is covered by solder, etc.

*2 There should not be the exposure of the ferrite bead if a hole is in top of filter, the ferrite bead should not be exposed.

Continued on the following page.

△Note • This PDF catalog is downloaded from the website of Murata Manufacturing co., ltd. Therefore, it's specifications are subject to change or our products in it may be discontinued without advance notice. Please check with our sales representatives or product engineers before ordering.
• This PDF catalog has only typical specifications because there is no space for detailed specifications. Therefore, please approve our product specifications or transact the approval sheet for product specifications before ordering.

Continued from the preceding page.

Insertion Loss Characteristics (Main Items)

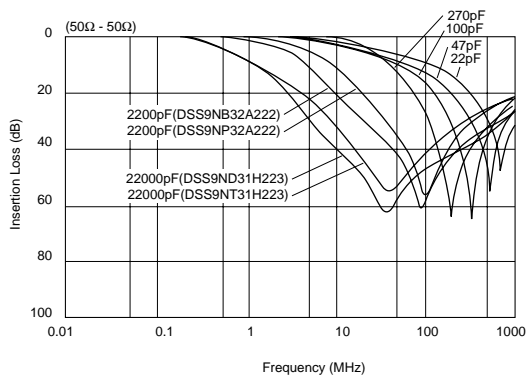

Equivalent Circuit

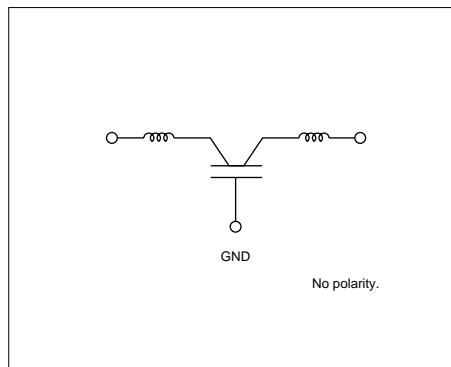

Part Number	Capacitance (pF)	Rated Voltage (Vdc)	Rated Current (A)	Operating Temperature Range
DSS9NC52A220	22 ±20%	100	7	-25 to +85°C
DSS9NC52A470	47 ±20%	100	7	-25 to +85°C
DSS9NC52A101	100 ±20%	100	7	-25 to +85°C
DSS9NC52A271	270 ±20%	100	7	-25 to +85°C
DSS9NC52A222	2200 ±20%	100	7	-25 to +85°C
DSS9NP32A222	2200 ±20%	100	7	-25 to +85°C
DSS9NC51H223	22000 50/-20%	50	7	-25 to +85°C
DSS9NT31H223	22000 50/-20%	50	7	-25 to +85°C

Rated current is 6A for taping type and its lead diameter is phi 0.6mm and three terminal in line arrangement.

Rated current is 7A for bulk type.

DSS9NP32A222/DSS9NT31H223 are low distortion types for audio IF circuits.

Please refer to Part Numbering instruction for type and length of lead.

● With Ferrite Beads DST9 Series

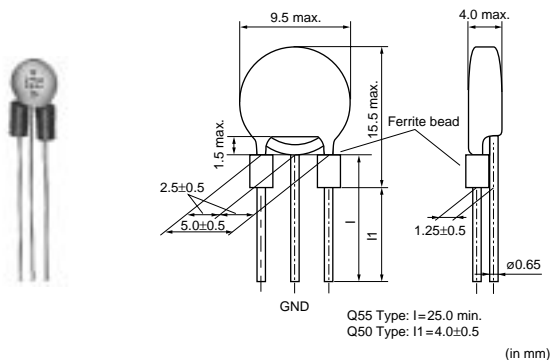

Insertion Loss Characteristics (Main Items)

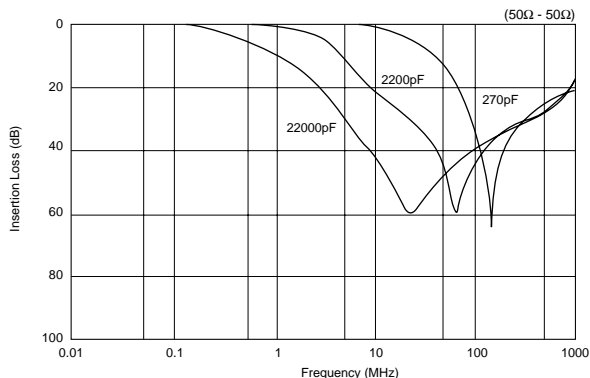

Equivalent Circuit

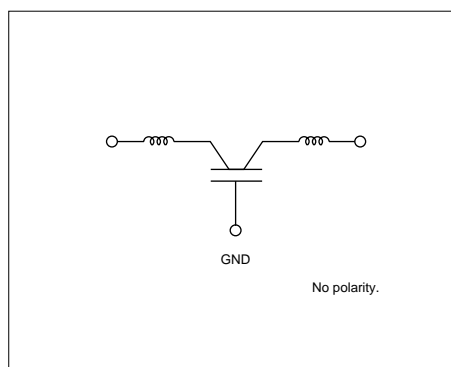

Note • This PDF catalog is downloaded from the website of Murata Manufacturing co., ltd. Therefore, it's specifications are subject to change or our products in it may be discontinued without advance notice. Please check with our sales representatives or product engineers before ordering.
• This PDF catalog has only typical specifications because there is no space for detailed specifications. Therefore, please approve our product specifications or transact the approval sheet for product specifications before ordering.

Part Number	Capacitance (pF)	Rated Voltage (Vdc)	Rated Current (A)	Operating Temperature Range
DST9NC52A271	270 ±20%	100	7	-25 to +85°C
DST9NC52A222	2200 ±20%	100	7	-25 to +85°C
DST9NC51H223	22000 50/-20%	50	7	-25 to +85°C

Rated current is 6A for taping type and its lead diameter is phi 0.6mm and three terminal in line arrangement.

Rated current is 7A for bulk type.

Please refer to Part Numbering instruction for type and length of lead.

Leaded EMIFIL[®] (Capacitor Type)

Heavy-duty Type

● DSN9H Series

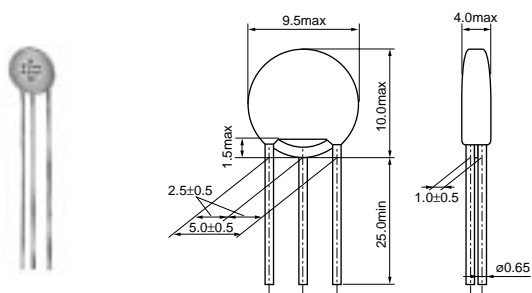

(in mm)

Insertion Loss Characteristics (Main Items)

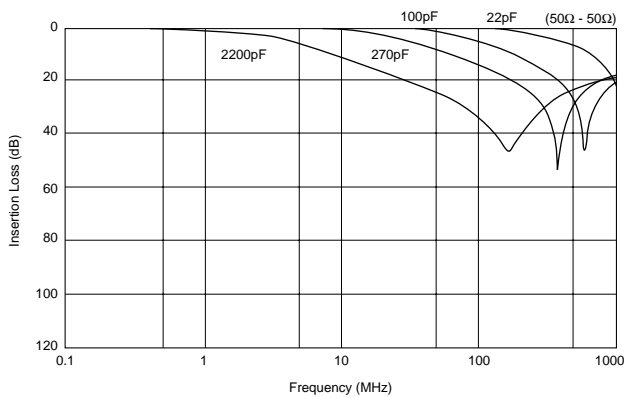

Equivalent Circuit

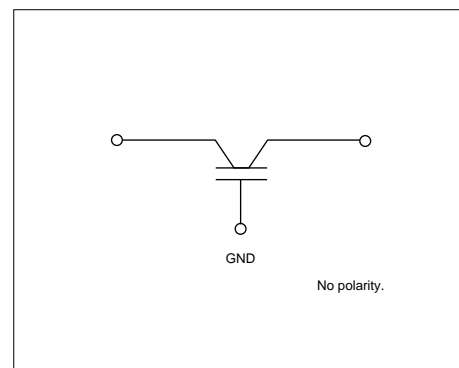

Part Number	Capacitance (pF)	Rated Voltage (Vdc)	Rated Current (A)	Operating Temperature Range
DSN9HB32E220	22 ±20%	250	6	-40 to +105°C
DSN9HB32E101	100 ±20%	250	6	-40 to +105°C
DSN9HB32E271	270 ±20%	250	6	-40 to +105°C
DSN9HB32E222	2200 ±20%	250	6	-40 to +105°C

Diameter of Lead is 0.6mm for taping type. Taping type is three terminal in line arrangement.

△Note • This PDF catalog is downloaded from the website of Murata Manufacturing co., ltd. Therefore, it's specifications are subject to change or our products in it may be discontinued without advance notice. Please check with our sales representatives or product engineers before ordering.
• This PDF catalog has only typical specifications because there is no space for detailed specifications. Therefore, please approve our product specifications or transact the approval sheet for product specifications before ordering.

● Built-in Ferrite Beads DSS9H Series

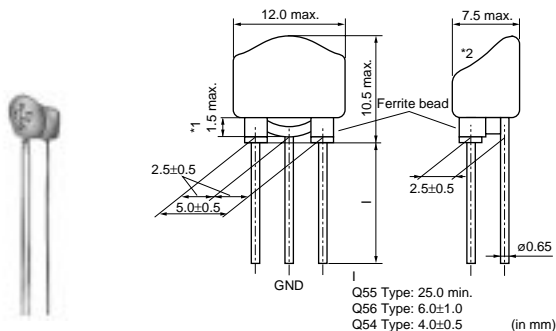

Q55 Type: 25.0 min.
Q56 Type: 6.0±1.0
Q54 Type: 4.0±0.5
(in mm)

*1 Coating extending on leads does not exceed the tangent line. Exposed electrode, if any, is covered by solder, etc.
*2 There should not be the exposure of the ferrite bead if a hole is in top of filter, the ferrite bead should not be exposed.

Insertion Loss Characteristics (Main Items)

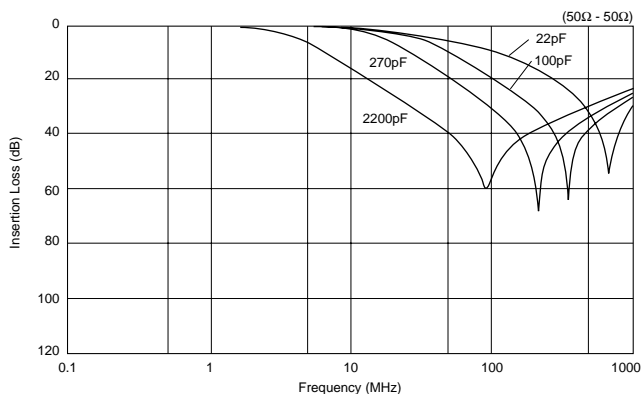

Equivalent Circuit

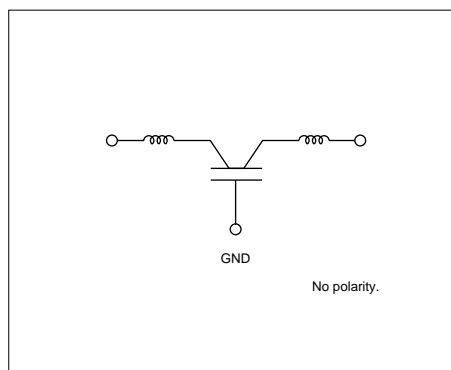

Part Number	Capacitance (pF)	Rated Voltage (Vdc)	Rated Current (A)	Operating Temperature Range
DSS9HB32E220	22 ±20%	250	6	-40 to +105°C
DSS9HB32E101	100 ±20%	250	6	-40 to +105°C
DSS9HB32E271	270 ±20%	250	6	-40 to +105°C
DSS9HB32E222	2200 ±20%	250	6	-40 to +105°C

Diameter of Lead is 0.6mm for taping type. Taping type is three terminal in line arrangement.

● With Ferrite Beads DST9H Series

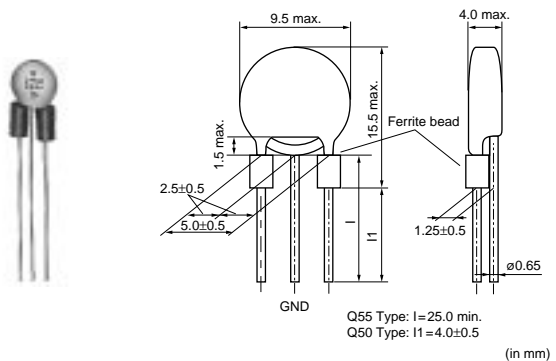

Q55 Type: l=25.0 min.
Q50 Type: l1=4.0±0.5
(in mm)

Continued on the following page.

Continued from the preceding page.

Insertion Loss Characteristics (Main Items)

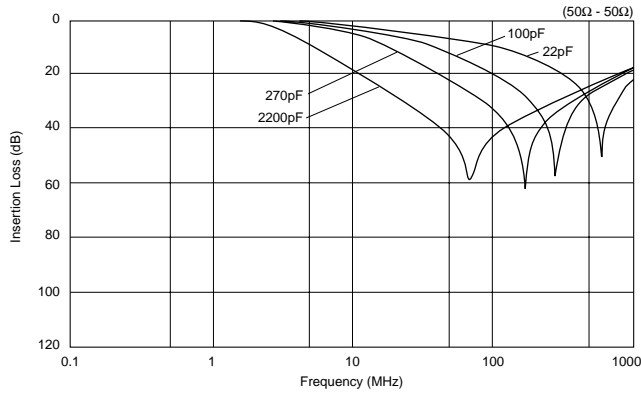

Equivalent Circuit

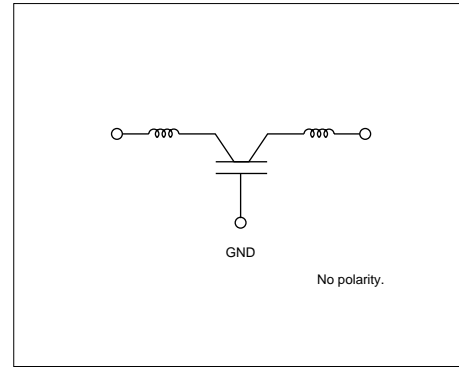

Part Number	Capacitance (pF)	Rated Voltage (Vdc)	Rated Current (A)	Operating Temperature Range
DST9HB32E220	22 ±20%	250	6	-40 to +105°C
DST9HB32E101	100 ±20%	250	6	-40 to +105°C
DST9HB32E271	270 ±20%	250	6	-40 to +105°C
DST9HB32E222	2200 ±20%	250	6	-40 to +105°C

Diameter of Lead is 0.6mm for taping type. Taping type is three terminal in line arrangement.

Block Type EMIFIL[®] (LC Combined)

SMD Type



BNX022/023

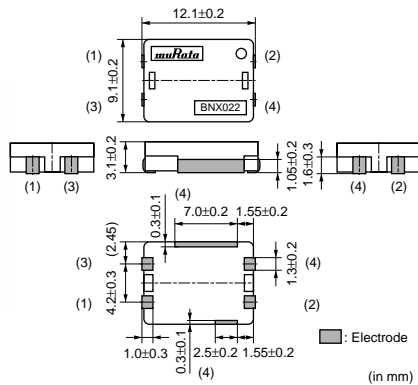

Equivalent Circuit

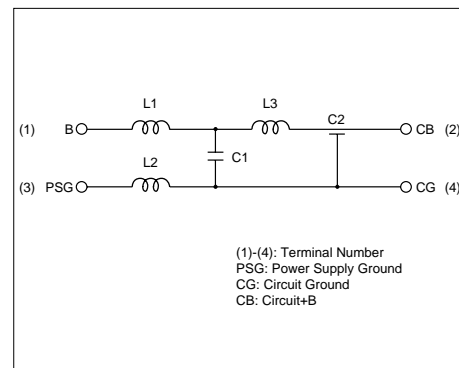

Part Number	Rated Voltage (Vdc)	Withstand Voltage (Vdc)	Rated Current (A)	Insulation Resistance (min.) (M ohm)	Insertion Loss
BNX022-01	50	125	10	500	1MHz to 1GHz:35dB min. (20 to 25 degrees C line impedance=50 ohm)
BNX023-01	100	250	15	500	1MHz to 1GHz:35dB min. (20 to 25 degrees C line impedance=50 ohm)

Operating Temperature Range: -40 to +125°C

In operating temperatures exceeding +85°C, derating of current is necessary.

Note • This PDF catalog is downloaded from the website of Murata Manufacturing co., ltd. Therefore, it's specifications are subject to change or our products in it may be discontinued without advance notice. Please check with our sales representatives or product engineers before ordering.
• This PDF catalog has only typical specifications because there is no space for detailed specifications. Therefore, please approve our product specifications or transact the approval sheet for product specifications before ordering.

Block Type EMIFIL® (LC Combined)

Lead Type

Equivalent Circuit

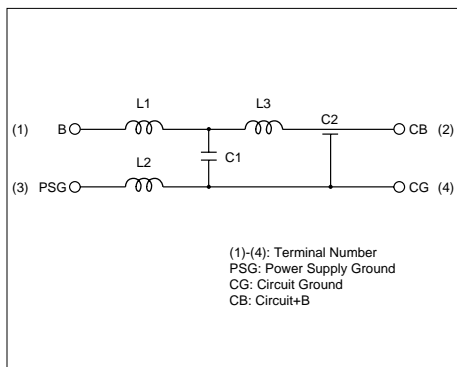

Noise Suppression Products/EMI Suppression Filters

2

● Lead Type

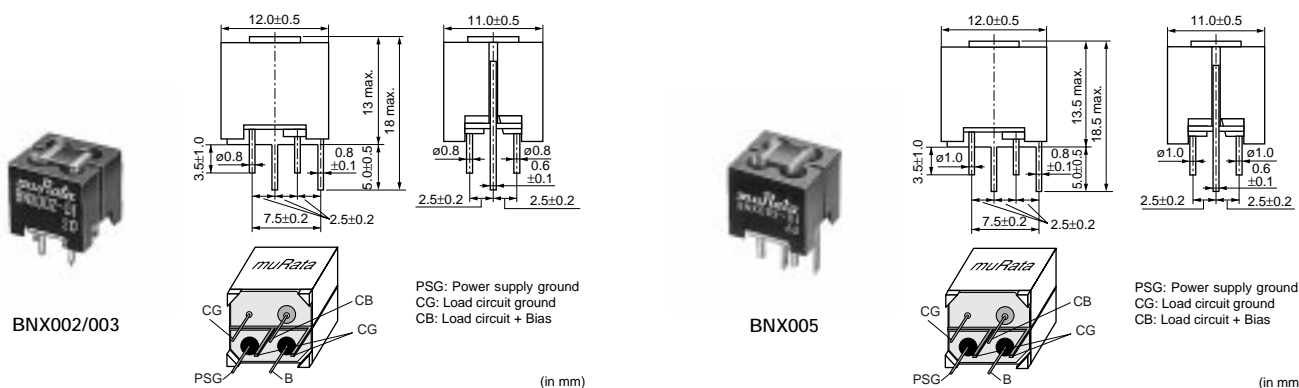

Part Number	Rated Voltage (Vdc)	Withstand Voltage (Vdc)	Rated Current (A)	Insulation Resistance (min.) (M ohm)	Insertion Loss
BNX002-01	50	125	10	100	1MHz to 1GHz:40dB min. (20 to 25 degrees C line impedance=50 ohm)
BNX003-01	150	375	10	100	5MHz to 1GHz:40dB min. (20 to 25 degrees C line impedance=50 ohm)
BNX005-01	50	125	15	100	1MHz to 1GHz:40dB min. (20 to 25 degrees C line impedance=50 ohm)

Operating Temperature Range: -30 to +85°C

● Lead Type Low Profile

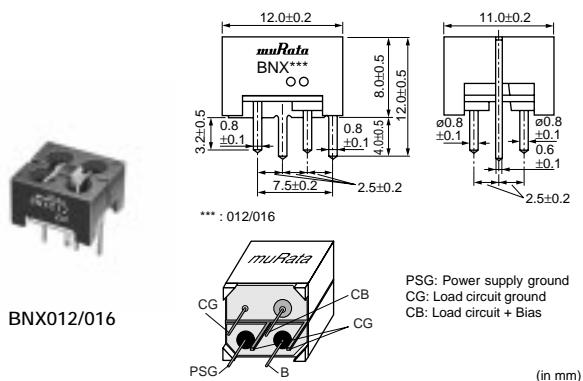

Part Number	Rated Voltage (Vdc)	Withstand Voltage (Vdc)	Rated Current (A)	Insulation Resistance (min.) (M ohm)	Insertion Loss
BNX012-01	50	125	15	500	1MHz to 1GHz:40dB min. (20 to 25 degrees C line impedance=50 ohm)
BNX016-01	25	62.5	15	50	100kHz to 1GHz:40dB min. (20 to 25 degrees C line impedance=50 ohm)

Operating Temperature Range: -40 to +125°C

In operating temperatures exceeding +85°C, derating of current is necessary.

⚠ Note • This PDF catalog is downloaded from the website of Murata Manufacturing co., ltd. Therefore, it's specifications are subject to change or our products in it may be discontinued without advance notice. Please check with our sales representatives or product engineers before ordering.
• This PDF catalog has only typical specifications because there is no space for detailed specifications. Therefore, please approve our product specifications or transact the approval sheet for product specifications before ordering.

Leaded Common Mode Choke Coil

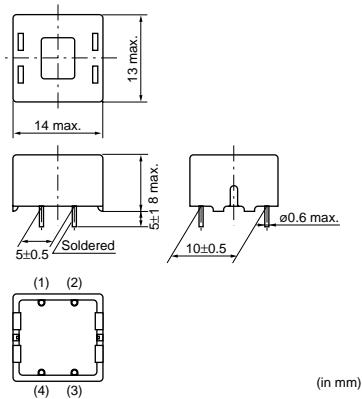

Insertion Loss Characteristics

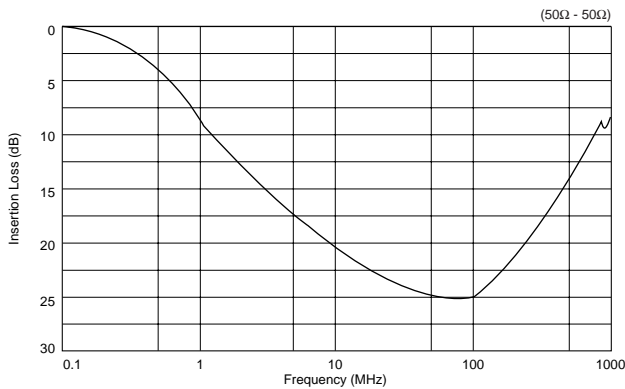

Equivalent Circuit

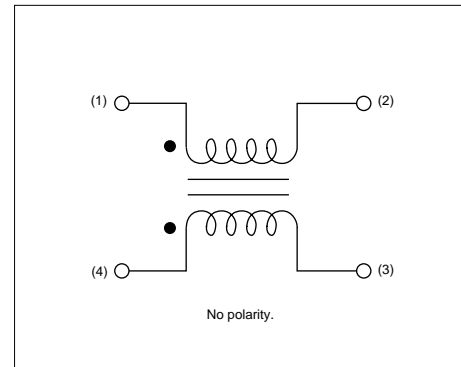

Part Number	Inductance (μH)	Rated Current (A)	Rated Voltage (Vdc)	Withstand Voltage (Vdc)
PLT09HN2003R0P1	20 min.	3	50	125

Operating Temperature Range: -40 to +85°C

EMIGUARD® (EMIFIL® with Varistor Function)

Lead Type EMIGUARD®

● For Semiconductor Protection VFR3V Series

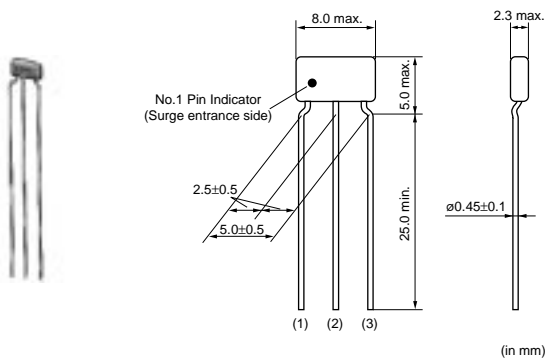

Part Number	Rated Voltage (Vdc)	Varistor Voltage (Vdc)	Capacitance (pF)	Rated Current (mA)	Peak Pulse Current (A)	Operating Temperature Range
VFR3VD31E131T51B	25	50 ±20%	130 ±20%	20	30	-25 to 85°C
VFR3VD31E131U31A	25	50 ±20%	130 ±20%	20	30	-25 to 85°C

⚠ Note • This PDF catalog is downloaded from the website of Murata Manufacturing co., ltd. Therefore, it's specifications are subject to change or our products in it may be discontinued without advance notice. Please check with our sales representatives or product engineers before ordering.
• This PDF catalog has only typical specifications because there is no space for detailed specifications. Therefore, please approve our product specifications or transact the approval sheet for product specifications before ordering.

● For Signal Line VFS6V Series

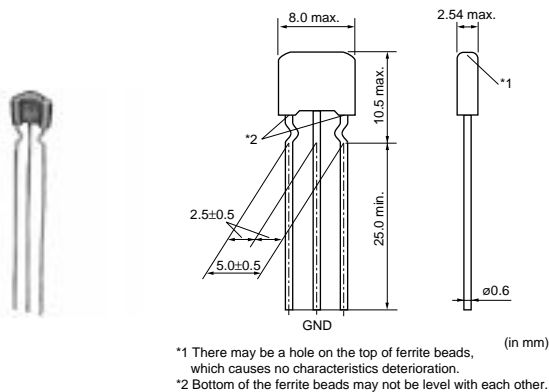

Equivalent Circuit

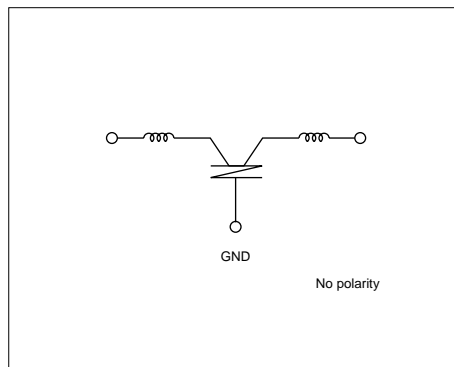

Part Number	Rated Voltage (Vdc)	Varistor Voltage (Vdc)	Capacitance (pF)	Rated Current (A)	Peak Pulse Current (A)	Operating Temperature Range
VFS6VD81E221T51B	25	50 ±20%	220 ±20%	6	100	-40 to 105°C
VFS6VD81E221U31A	25	50 ±20%	220 ±20%	6	100	-40 to 105°C

● For Large Current VFS9V Series

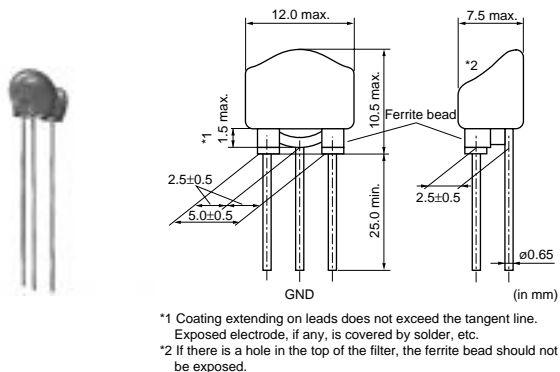

Equivalent Circuit

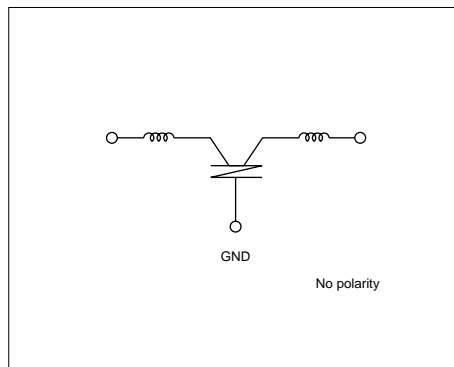

Part Number	Rated Voltage (Vdc)	Varistor Voltage (Vdc)	Capacitance (pF)	Rated Current (A)	Operating Temperature Range
VFS9VD31B223Q55B	12	22 ±20%	22000 +50/-20%	7	-40 to 100°C
VFS9VD31B223Q91J	12	22 ±20%	22000 +50/-20%	6	-40 to 100°C
VFS9VD31B223Q92J	12	22 ±20%	22000 +50/-20%	6	-40 to 100°C
VFS9VD31B223Q93J	12	22 ±20%	22000 +50/-20%	6	-40 to 100°C

AC Line Filters

Common Mode Choke Coil

Equivalent Circuit

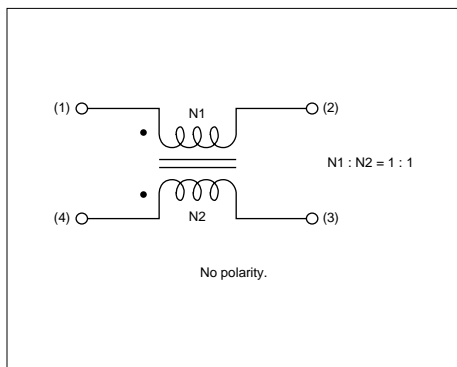

● PLA10 Series Standard Winding Type

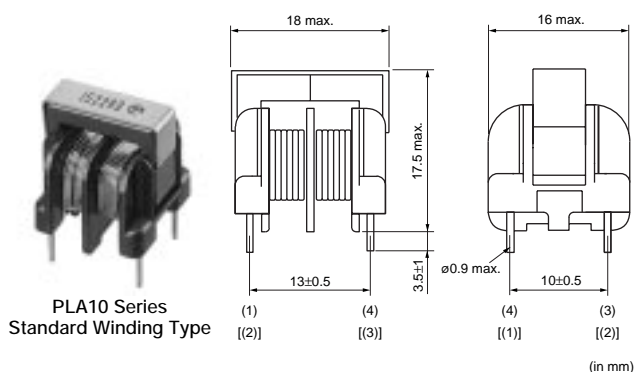

Part Number	Common Mode Inductance (min.) (mH)	Rated Current (A)	Rated Voltage (V)	Insulation Resistance (min.) (M ohm)
PLA10AN1522R0R2	1.5	2.0	300	100
PLA10AN1821R7R2	1.8	1.7	300	100
PLA10AN2221R5R2	2.2	1.5	300	100
PLA10AN3021R3R2	3.0	1.3	300	100
PLA10AN3521R2R2	3.5	1.2	300	100
PLA10AN5521R0R2	5.5	1.0	300	100
PLA10AN7420R8R2	7.4	0.8	300	100
PLA10AN1030R7R2	10.0	0.7	300	100
PLA10AN1230R6R2	12.0	0.6	300	100
PLA10AN2030R5R2	20.0	0.5	300	100
PLA10AN3030R4R2	30.0	0.4	300	100
PLA10AN4330R3R2	43.0	0.3	300	100

Operating Temperature Range (Ambient Temperature Range + Winding Temperature Rise): -25°C to 120°C Winding Temperature Rise (at Rated Current) (max.): 60K

△Note • This PDF catalog is downloaded from the website of Murata Manufacturing co., ltd. Therefore, it's specifications are subject to change or our products in it may be discontinued without advance notice. Please check with our sales representatives or product engineers before ordering.
• This PDF catalog has only typical specifications because there is no space for detailed specifications. Therefore, please approve our product specifications or transact the approval sheet for product specifications before ordering.

● PLA10 Series Standard Winding Type (Safety Standard Recognized - Safety Standards: EN60065)

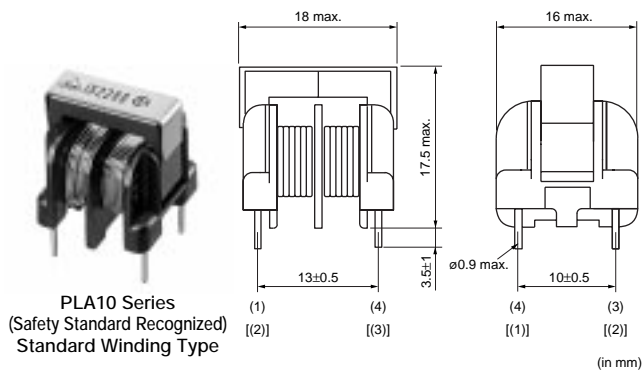

Part Number	Common Mode Inductance (min.) (mH)	Rated Current (A)	Rated Voltage (V)	Insulation Resistance (min.) (M ohm)
PLA10AS1522R0R2	1.5	2.0	250	100
PLA10AS1821R7R2	1.8	1.7	250	100
PLA10AS2221R5R2	2.2	1.5	250	100
PLA10AS3021R3R2	3.0	1.3	250	100
PLA10AS3521R2R2	3.5	1.2	250	100
PLA10AS5521R0R2	5.5	1.0	250	100
PLA10AS7420R8R2	7.4	0.8	250	100
PLA10AS1030R7R2	10.0	0.7	250	100
PLA10AS1230R6R2	12.0	0.6	250	100
PLA10AS2030R5R2	20.0	0.5	250	100
PLA10AS3030R4R2	30.0	0.4	250	100
PLA10AS4330R3R2	43.0	0.3	250	100

Operating Temperature Range: -25°C to 60°C Winding Temperature Rise (at Rated Current) (max.): 60K

● PLA10 Series Sectional Winding Type

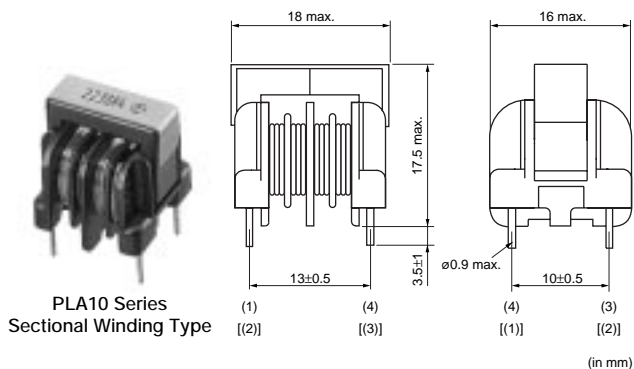

Part Number	Common Mode Inductance (min.) (mH)	Rated Current (A)	Rated Voltage (V)	Insulation Resistance (min.) (M ohm)
PLA10AN9012R0D2	0.9	2.0	300	100
PLA10AN1321R7D2	1.3	1.7	300	100
PLA10AN1821R5D2	1.8	1.5	300	100
PLA10AN2021R3D2	2.0	1.3	300	100
PLA10AN3621R0D2	3.6	1.0	300	100
PLA10AN7720R7D2	7.7	0.7	300	100
PLA10AN1330R5D2	13.0	0.5	300	100
PLA10AN2230R4D2	22.0	0.4	300	100
PLA10AN3630R3D2	36.0	0.3	300	100

Operating Temperature Range (Ambient Temperature Range + Winding Temperature Rise): -25°C to 120°C Winding Temperature Rise (at Rated Current) (max.): 60K

● PLA10 Series Sectional Winding Type (Safety Standard Recognized - Safety Standards: EN60065)

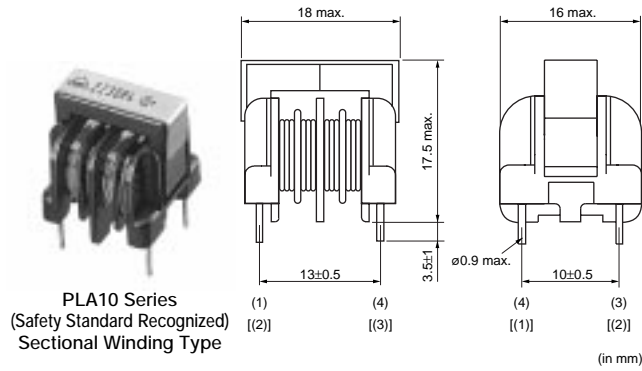

Part Number	Common Mode Inductance (min.) (mH)	Rated Current (A)	Rated Voltage (V)	Insulation Resistance (min.) (M ohm)
PLA10AS9012R0D2	0.9	2.0	250	100
PLA10AS1321R7D2	1.3	1.7	250	100
PLA10AS1821R5D2	1.8	1.5	250	100
PLA10AS2021R3D2	2.0	1.3	250	100
PLA10AS3621R0D2	3.6	1.0	250	100
PLA10AS7720R7D2	7.7	0.7	250	100
PLA10AS1330R5D2	13.0	0.5	250	100
PLA10AS2230R4D2	22.0	0.4	250	100
PLA10AS3630R3D2	36.0	0.3	250	100

Operating Temperature Range: -25°C to 60°C Winding Temperature Rise (at Rated Current) (max.): 60K

● PLH10 Series

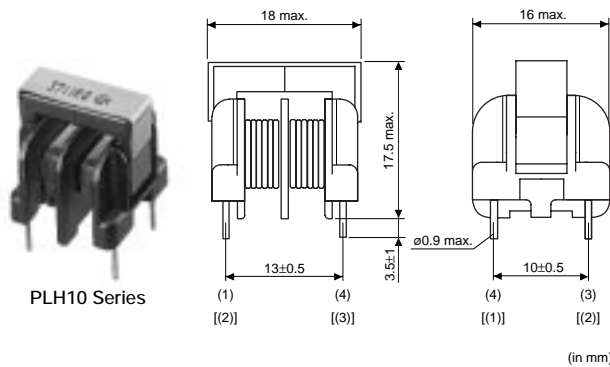

Part Number	Common Mode Inductance (min.) (μH)	Rated Current (A)	Rated Voltage (V)	Insulation Resistance (min.) (M ohm)
PLH10AN7003R6P2	70	3.6	300	100
PLH10AN1112R6P2	110	2.6	300	100
PLH10AN1612R1P2	160	2.1	300	100
PLH10AN2211R5P2	220	1.5	300	100
PLH10AN2911R2P2	290	1.2	300	100
PLH10AN3711R0P2	370	1.0	300	100

Operating Temperature Range (Ambient Temperature Range + Winding Temperature Rise): -25°C to 120°C Winding Temperature Rise (at Rated Current) (max.): 60K

△Note • This PDF catalog is downloaded from the website of Murata Manufacturing co., ltd. Therefore, it's specifications are subject to change or our products in it may be discontinued without advance notice. Please check with our sales representatives or product engineers before ordering.
• This PDF catalog has only typical specifications because there is no space for detailed specifications. Therefore, please approve our product specifications or transact the approval sheet for product specifications before ordering.

● PLH10 Series (Safety Standard Recognized - Safety Standards: EN60065)

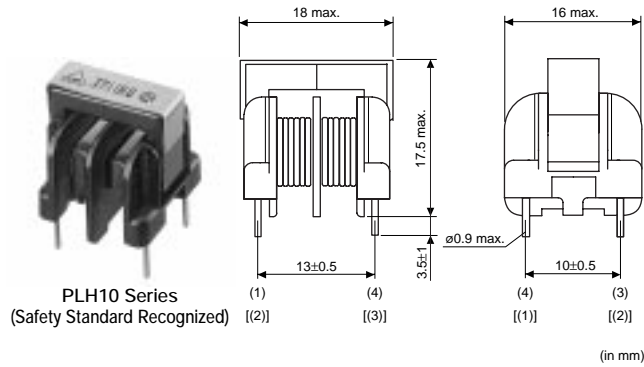

Part Number	Common Mode Inductance (min.) (μH)	Rated Current (A)	Rated Voltage (V)	Insulation Resistance (min.) (M ohm)
PLH10AS7003R6P2	70	3.6	250	100
PLH10AS1112R6P2	110	2.6	250	100
PLH10AS1612R1P2	160	2.1	250	100
PLH10AS2211R5P2	220	1.5	250	100
PLH10AS2911R2P2	290	1.2	250	100
PLH10AS3711R0P2	370	1.0	250	100

Operating Temperature Range: -25°C to 60°C Winding Temperature Rise (at Rated Current) (max.): 60K

AC Line Filters

Hybrid Choke Coils

Equivalent Circuit

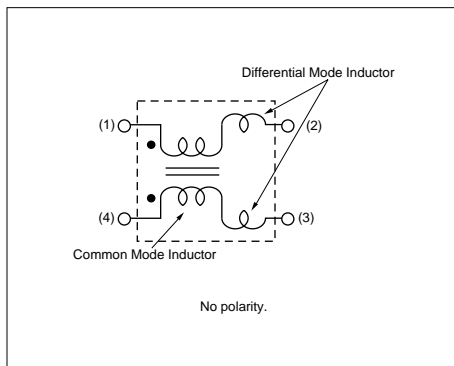

● PLY10 Series Standard Winding Type

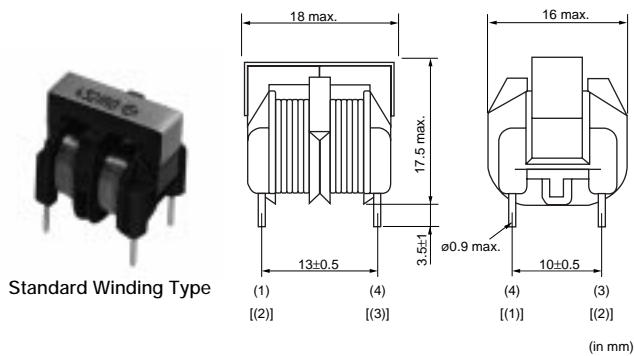

Part Number	Common Mode Inductance (min.) (mH)	Normal Mode Inductance (min.) (μH)	Rated Current (A)	Rated Voltage (Vac)
PLY10AN9012R0R2	0.9	65	2.0	300
PLY10AN1121R8R2	1.1	90	1.8	300
PLY10AN1521R6R2	1.5	110	1.6	300
PLY10AN2121R4R2	2.1	150	1.4	300
PLY10AN2821R2R2	2.8	190	1.2	300
PLY10AN4321R0R2	4.3	300	1.0	300
PLY10AN6220R8R2	6.2	400	0.8	300
PLY10AN8720R7R2	8.7	530	0.7	300
PLY10AN9920R6R2	9.9	690	0.6	300
PLY10AN1430R5R2	14.0	1000	0.5	300

Operating Temperature Range (Ambient Temperature Range+Winding Temperature Rise): -25°C to 120°C Winding Temperature Rise (at Rated Current) (max.): 60K

● PLY10 Series Standard Winding Type (Safety Standard Recognized - Safety Standards: EN60065)

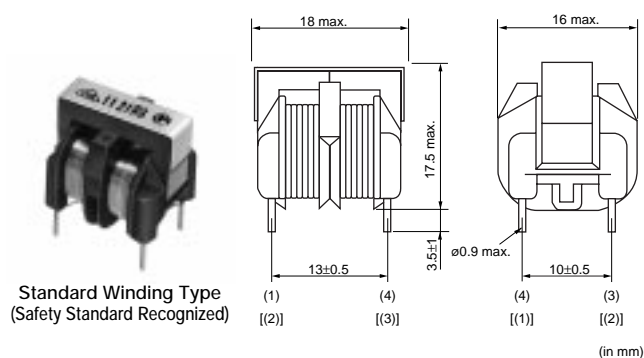

Part Number	Common Mode Inductance (min.) (mH)	Normal Mode Inductance (min.) (μH)	Rated Current (A)	Rated Voltage (Vac)
PLY10AS9012R0R2	0.9	65	2.0	300
PLY10AS1121R8R2	1.1	90	1.8	300
PLY10AS1521R6R2	1.5	110	1.6	300
PLY10AS2121R4R2	2.1	150	1.4	300
PLY10AS2821R2R2	2.8	190	1.2	300
PLY10AS4321R0R2	4.3	300	1.0	300
PLY10AS6220R8R2	6.2	400	0.8	300
PLY10AS8720R7R2	8.7	530	0.7	300
PLY10AS9920R6R2	9.9	690	0.6	300
PLY10AS1430R5R2	14.0	1000	0.5	300

Operating Temperature Range (Ambient Temperature Range+Winding Temperature Rise): -25°C to 120°C Winding Temperature Rise (at Rated Current) (max.): 60K

● PLY10 Series Sectional Winding Type

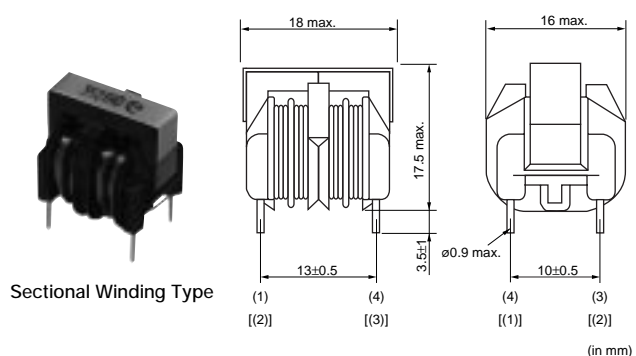

△Note • This PDF catalog is downloaded from the website of Murata Manufacturing co., ltd. Therefore, it's specifications are subject to change or our products in it may be discontinued without advance notice. Please check with our sales representatives or product engineers before ordering.
• This PDF catalog has only typical specifications because there is no space for detailed specifications. Therefore, please approve our product specifications or transact the approval sheet for product specifications before ordering.

Part Number	Common Mode Inductance (min.) (mH)	Normal Mode Inductance (min.) (μH)	Rated Current (A)	Rated Voltage (Vac)
PLY10AN7012R0D2	0.7	50	2.0	300
PLY10AN1121R7D2	1.1	65	1.7	300
PLY10AN1421R4D2	1.4	110	1.4	300
PLY10AN2321R2D2	2.3	160	1.2	300
PLY10AN3521R0D2	3.5	240	1.0	300
PLY10AN4420R8D2	4.4	320	0.8	300
PLY10AN8720R7D2	8.7	500	0.7	300
PLY10AN9720R6D2	9.7	670	0.6	300
PLY10AN1130R5D2	11.0	840	0.5	300

Operating Temperature Range (Ambient Temperature Range+Winding Temperature Rise): -25°C to 120°C Winding Temperature Rise (at Rated Current) (max.): 60K

● PLY10 Series Sectional Winding Type (Safety Standard Recognized - Safety Standards: EN60065)

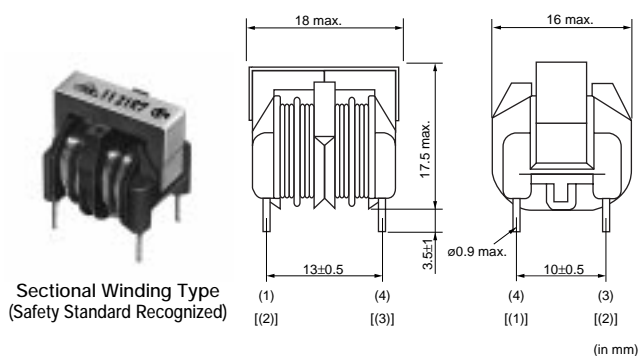

Part Number	Common Mode Inductance (min.) (mH)	Normal Mode Inductance (min.) (μH)	Rated Current (A)	Rated Voltage (Vac)
PLY10AS7012R0D2	0.7	50	2.0	300
PLY10AS1121R7D2	1.1	65	1.7	300
PLY10AS1421R4D2	1.4	110	1.4	300
PLY10AS2321R2D2	2.3	160	1.2	300
PLY10AS3521R0D2	3.5	240	1.0	300
PLY10AS4420R8D2	4.4	320	0.8	300
PLY10AS8720R7D2	8.7	500	0.7	300
PLY10AS9720R6D2	9.7	670	0.6	300
PLY10AS1130R5D2	11.0	840	0.5	300

Operating Temperature Range (Ambient Temperature Range+Winding Temperature Rise): -25°C to 120°C Winding Temperature Rise (at Rated Current) (max.): 60K

● PLY17 Type

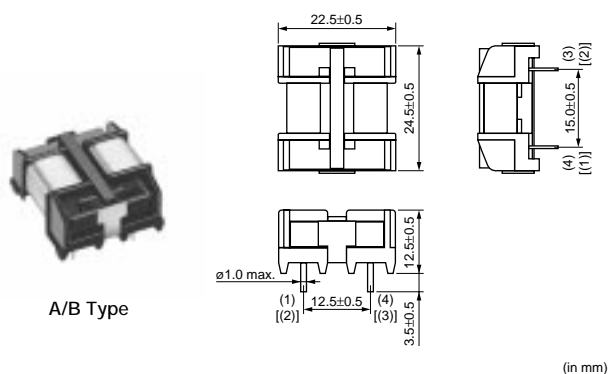

Equivalent Circuit

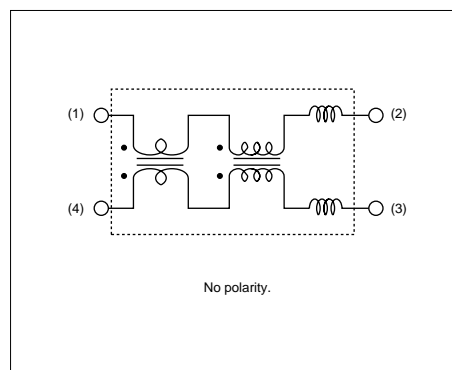

A Type

Part Number	Common Mode Inductance (min.) (mH)	Normal Mode Inductance (min.) (μ H)	Rated Current (A)	Rated Voltage (Vac)
PLY17BN4912R4A2	0.49	18	2.4	300
PLY17BN9612R0A2	0.96	36	2.0	300
PLY17BN1023R0A2	1.0	36	3.0	300
PLY17BN1121R8A2	1.1	44	1.8	300
PLY17BN1721R5A2	1.7	67	1.5	300
PLY17BN2921R2A2	2.9	110	1.2	300
PLY17BN3721R0A2	3.7	140	1.0	300
PLY17BN5620R8A2	5.6	210	0.8	300
PLY17BN7820R7A2	7.8	290	0.7	300
PLY17BN9320R6A2	9.3	350	0.6	300

Operating Temperature Range (Ambient Temperature Range+Winding Temperature Rise): -25°C to 120°C Winding Temperature Rise (at Rated Current) (max.): 60K

B Type

Part Number	Common Mode Inductance (min.) (mH)	Normal Mode Inductance (min.) (μ H)	Rated Current (A)	Rated Voltage (Vac)
PLY17BN4912R4B2	0.49	24	2.4	300
PLY17BN9612R0B2	0.96	47	2.0	300
PLY17BN1023R0B2	1.0	47	3.0	300
PLY17BN1121R8B2	1.1	58	1.8	300
PLY17BN1721R5B2	1.7	88	1.5	300
PLY17BN2921R2B2	2.9	140	1.2	300
PLY17BN3721R0B2	3.7	180	1.0	300
PLY17BN5620R8B2	5.6	280	0.8	300
PLY17BN7820R7B2	7.8	390	0.7	300
PLY17BN9320R6B2	9.3	460	0.6	300

Operating Temperature Range (Ambient Temperature Range+Winding Temperature Rise): -25°C to 120°C Winding Temperature Rise (at Rated Current) (max.): 60K

● PLY17 Series (Safety Standard Recognized - Safety Standards: EN60065)

Equivalent Circuit

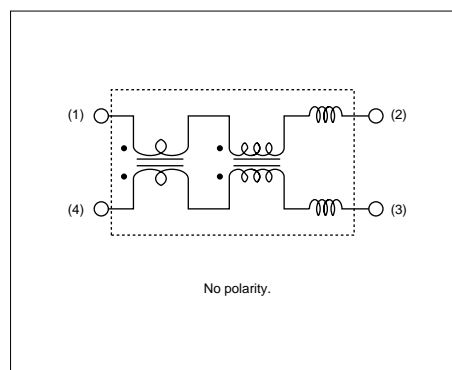
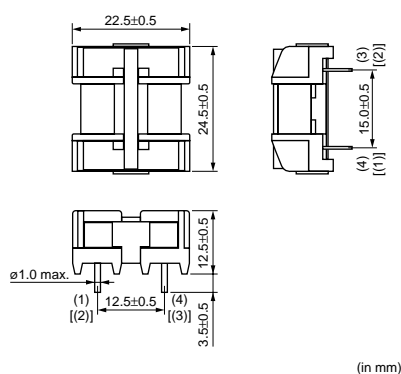
A Type

Part Number	Common Mode Inductance (min.) (mH)	Normal Mode Inductance (min.) (μ H)	Rated Current (A)	Rated Voltage (Vac)
PLY17BS4912R4A2	0.49	18	2.4	250
PLY17BS9612R0A2	0.96	36	2.0	250
PLY17BS1023R0A2	1.0	36	3.0	250
PLY17BS1121R8A2	1.1	44	1.8	250
PLY17BS1721R5A2	1.7	67	1.5	250
PLY17BS2921R2A2	2.9	110	1.2	250
PLY17BS3721R0A2	3.7	140	1.0	250
PLY17BS5620R8A2	5.6	210	0.8	250
PLY17BS7820R7A2	7.8	290	0.7	250
PLY17BS9320R6A2	9.3	350	0.6	250

Operating Temperature Range (Ambient Temperature Range+Winding Temperature Rise): -25°C to 120°C Winding Temperature Rise (at Rated Current) (max.): 60K

△Note • This PDF catalog is downloaded from the website of Murata Manufacturing co., Ltd. Therefore, it's specifications are subject to change or our products in it may be discontinued without advance notice. Please check with our sales representatives or product engineers before ordering.
 • This PDF catalog has only typical specifications because there is no space for detailed specifications. Therefore, please approve our product specifications or transact the approval sheet for product specifications before ordering.

B Type

Part Number	Common Mode Inductance (min.) (mH)	Normal Mode Inductance (min.) (μH)	Rated Current (A)	Rated Voltage (Vac)
PLY17BS4912R4B2	0.49	24	2.4	250
PLY17BS9612R0B2	0.96	47	2.0	250
PLY17BS1023R0B2	1.0	47	3.0	250
PLY17BS1121R8B2	1.1	58	1.8	250
PLY17BS1721R5B2	1.7	88	1.5	250
PLY17BS2921R2B2	2.9	140	1.2	250
PLY17BS3721R0B2	3.7	180	1.0	250
PLY17BS5620R8B2	5.6	280	0.8	250
PLY17BS7820R7B2	7.8	390	0.7	250
PLY17BS9320R6B2	9.3	460	0.6	250

Operating Temperature Range (Ambient Temperature Range+Winding Temperature Rise): -25°C to 120°C Winding Temperature Rise (at Rated Current) (max.): 60K

Microwave Absorber



EA10 Series



EA20/21/22/30 Series

Part Number	Applicable Frequency (Typ.)	Thickness (Typ.) (mm)	Flame Resistance	Halogen	Operating Temperature Range
EA1026A100	20.0GHz	1.0	UL94V-0	Halogen Free	-40 to +80°C
EA1026A160	11.5GHz	1.6	UL94V-0	Halogen Free	-40 to +80°C
EA1026A180	10.0GHz	1.8	UL94V-0	Halogen Free	-40 to +80°C
EA1046A180	5.8GHz	1.8	UL94V-0	Halogen Free	-40 to +80°C
EA1075A270	2.5GHz	2.7	UL94V-0	Halogen Free	-40 to +80°C
EA2070A020	0.1 to 3.0GHz	0.20	-	Halogen Free	-40 to +120°C
EA2070A050	0.1 to 3.0GHz	0.50	-	Halogen Free	-40 to +120°C
EA2070A100	0.1 to 3.0GHz	1.00	-	Halogen Free	-40 to +120°C
EA2070B005	0.1 to 3.0GHz	0.05	-	Halogen Free	-40 to +120°C
EA2070B010	0.1 to 3.0GHz	0.10	-	Halogen Free	-40 to +120°C
EA2070B013	0.1 to 3.0GHz	0.13	-	Halogen Free	-40 to +120°C
EA2070B020	0.1 to 3.0GHz	0.20	-	Halogen Free	-40 to +120°C
EA2070B050	0.1 to 3.0GHz	0.50	-	Halogen Free	-40 to +120°C
EA2100A020	0.1 to 3.0GHz	0.20	UL94V-0	-	-40 to +120°C
EA2100A050	0.1 to 3.0GHz	0.50	UL94V-0	-	-40 to +120°C
EA2100A100	0.1 to 3.0GHz	1.00	UL94V-0	-	-40 to +120°C
EA2100B020	0.1 to 3.0GHz	0.20	UL94V-0	-	-40 to +120°C
EA2100B050	0.1 to 3.0GHz	0.50	UL94V-0	-	-40 to +120°C
EA2100B100	0.1 to 3.0GHz	1.00	UL94V-0	-	-40 to +120°C
EA3008U025	0.1 to 3.0GHz	0.25	UL94V-0	Halogen Free	-40 to +120°C
EA3008U035	0.1 to 3.0GHz	0.35	UL94V-0	Halogen Free	-40 to +120°C
EA3008U050	0.1 to 3.0GHz	0.50	UL94V-0	Halogen Free	-40 to +120°C
EA3008U100	0.1 to 3.0GHz	1.00	UL94V-0	Halogen Free	-40 to +120°C
EA3008U250	0.1 to 3.0GHz	2.50	UL94V-0	Halogen Free	-40 to +120°C

⚠️Note • This PDF catalog is downloaded from the website of Murata Manufacturing co., Ltd. Therefore, it's specifications are subject to change or our products in it may be discontinued without advance notice. Please check with our sales representatives or product engineers before ordering.
• This PDF catalog has only typical specifications because there is no space for detailed specifications. Therefore, please approve our product specifications or transact the approval sheet for product specifications before ordering.

Ferrite Core for EMI Suppression

Beads Core

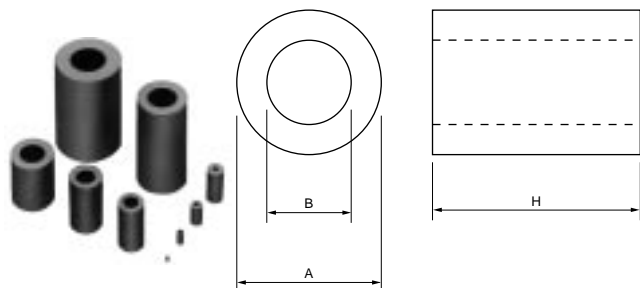

Part Number	Phi A: Outer Dimension (mm)	Phi B: Inner Dimension (mm)	H: Length Dimension (mm)	Impedance at 100MHz (1 turn) (ohm)	Note
FSRH021049RNB01B	1.95	1.02	4.9	34	-
FSRH030060RNB00B	3.36	1.1	6.0	74	-
FSRH041D85RNB00B	3.6	1.0	4.85	66	-
FSRH044C00RNB00B	3.6	1.5	3.0	40	-
FSRH044040RNB00B	3.6	1.5	4.0	50	-
FSRH044050RNB00B	3.6	1.5	5.0	53	-
FSRH050050RN000B	4.7	1.4	5.0	64	-
FSRH050100RN000B	4.7	1.4	10.0	120	-
FSRH060080RN001B	5.5	2.7	8.0	64	-
FSRH070080RN000B	7.0	4.0	8.0	59	-
FSRH070140RN000B	7.0	4.0	14.0	82	-
FSRH074140RNF00B	7.0	4.0	14.0	93	Division Type
FSRH090100RN000B	9.0	5.0	10.0	72	For USB/IEEE1394
FSRH090160RN000B	9.0	5.0	16.0	100	For USB/IEEE1394
FSRH090200RN000T	9.0	5.0	20.0	135	For USB/IEEE1394
FSRH091100RN000B	9.0	4.3	10.0	94	For USB/IEEE1394
FSRH091160RN000T	9.0	4.3	16.0	145	For USB/IEEE1394
FSRH100150RTB00T	10.0	6.0	15.0	92	For USB/IEEE1394
FSRH120150RT000T	12.0	7.0	15.0	90	For USB/IEEE1394
FSRH120200RT000T	12.0	7.0	20.0	120	For USB/IEEE1394
FSRH120285RT000T	12.0	7.0	28.5	175	For USB/IEEE1394
FSRH121150RT000T	12.0	5.6	15.0	130	For USB/IEEE1394
FSRH121200RT000T	12.0	5.6	20.0	170	For USB/IEEE1394
FSRH121250RT000T	12.0	5.6	25.0	223	For USB/IEEE1394
FSRH142150RX000T	14.0	8.0	15.0	97	-
FSRH142200RX000T	14.0	8.0	20.0	127	-
FSRH142280RX000T	14.0	8.0	28.0	170	-
FSRH162200RN000T	16.3	8.3	20.0	162	-
FSRH162280RN000T	16.3	8.3	28.0	225	-
FSRH190285RT000T	19.0	10.0	28.5	200	-

Ferrite Core for EMI Suppression

Ring Core

Noise Suppression Products/EMI Suppression Filters

2

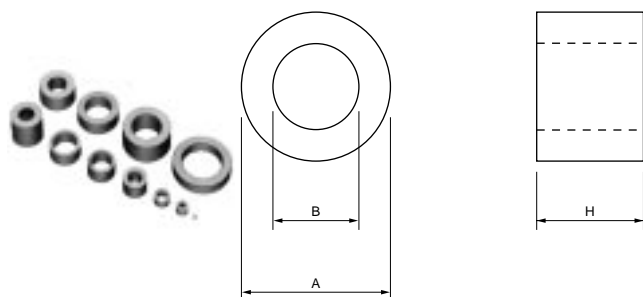

Part Number	Phi A: Outer Dimension (mm)	Phi B: Inner Dimension (mm)	H: Length Dimension (mm)	Impedance at 100MHz (3 turns) (ohm)	Note
FSRB041020RNB00B	3.6	1.0	2.0	267	-
FSRB044020RNB00B	3.6	1.5	2.0	178	-
FSRB060040RNB00B	5.5	2.7	4.0	290	-
FSRB071040RNB00B	7.0	4.0	4.0	222	-
FSRB090060RNB00B	9.0	5.0	6.0	356	For USB/IEEE1394
FSRB090080RNB00B	9.0	5.0	8.0	466	For USB/IEEE1394
FSRB091060RNB00B	9.0	4.3	6.0	451	For USB/IEEE1394
FSRB091080RNB00B	9.0	4.3	8.0	582	For USB/IEEE1394
FSRB100030RTB00B	10.0	6.0	3.0	170	For USB/IEEE1394
FSRB100060RTB00B	10.0	6.0	6.0	316	For USB/IEEE1394
FSRB100080RTB00B	10.0	6.0	8.0	388	For USB/IEEE1394
FSRB100100RTB00B	10.0	6.0	10.0	475	For USB/IEEE1394
FSRB120050RTB00T	12.0	7.0	5.0	264	For USB/IEEE1394
FSRB120060RTB00T	12.0	7.0	6.0	310	For USB/IEEE1394
FSRB120080RTB00T	12.0	7.0	8.0	400	For USB/IEEE1394
FSRB120100RTB00T	12.0	7.0	10.0	450	For USB/IEEE1394
FSRB121060RTB00T	12.0	5.6	6.0	406	For USB/IEEE1394
FSRB121080RTB00T	12.0	5.6	8.0	490	For USB/IEEE1394
FSRB121100RTB00T	12.0	5.6	10.0	535	For USB/IEEE1394
FSRB140080RNB00T	14.0	10.0	8.0	340	-
FSRB140140RNB00T	14.0	10.0	14.0	450	-
FSRB142060RXB00T	14.0	8.0	6.0	325	-
FSRB142080RXB00T	14.0	8.0	8.0	415	-
FSRB142100RXB00T	14.0	8.0	10.0	492	-
FSRB143140RNB00T	14.0	11.0	14.0	364	-
FSRB160G75RN000T	16.0	12.0	7.75	247	-
FSRB162030RNB00T	16.3	8.3	3.0	230	-
FSRB162050RN000T	16.3	8.3	5.0	310	-
FSRB162100RNB00T	16.3	8.3	10.0	557	-
FSRB162160RN000T	16.3	8.3	16.0	640	-
FSRB190060RTB00T	19.0	10.0	6.0	360	-
FSRB190100RT000T	19.0	10.0	10.0	480	-
FSRB190180RT000T	19.0	10.0	18.0	619	-
FSRB221080RNB00T	22.0	14.0	8.0	360	-
FSRB250120RT000T	25.0	15.0	12.0	470	-
FSRB300080RT000T	30.0	20.0	8.0	300	-

Ferrite Core for EMI Suppression

Flat Cables

● Thin Type

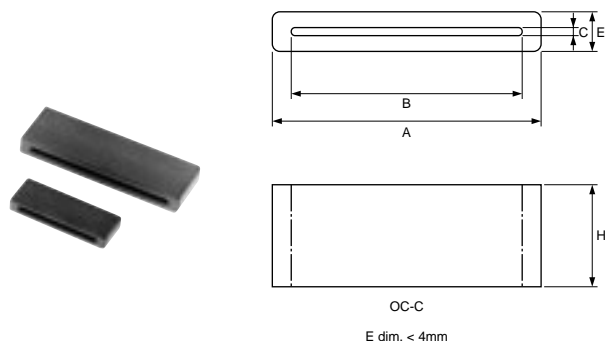

Part Number	A: Outer Dimension (mm)	B: Inner Dimension (mm)	H: Length Dimension (mm)	E: Width Dimension (mm)	C: Gap Dimension (mm)	Impedance at 100MHz (ohm)	Number of Turn	Note
FSRC080030RTB00B	8.0	6.0	3.0	2.7	0.7	28	1	Thin Type
FSRC080060RTB00B	8.0	6.0	6.0	2.7	0.7	39	1	Thin Type
FSRC080090RTB00B	8.0	6.0	9.0	2.7	0.7	51	1	Thin Type
FSRC080120RTB00B	8.0	6.0	12.0	2.7	0.7	63	1	Thin Type
FSRC100030RTB00B	10.0	8.0	3.0	1.85	0.7	24	1	Ultra Thin Type
FSRC100040RTB00B	10.0	8.0	4.0	1.85	0.7	25	1	Ultra Thin Type
FSRC100050RTB00B	10.0	8.0	5.0	1.85	0.7	27	1	Ultra Thin Type
FSRC100060RTB00B	10.0	8.0	6.0	1.85	0.7	30	1	Ultra Thin Type
FSRC120020RXB00B	11.5	8.0	2.0	3.0	0.7	24	1	Thin Type
FSRC120050RXB00B	11.5	8.0	5.0	3.0	0.7	35	1	Thin Type
FSRC120060RXB00B	11.5	8.0	6.0	3.0	0.7	36	1	Thin Type
FSRC120090RXB00B	11.5	8.0	9.0	3.0	0.7	48	1	Thin Type
FSRC120120RXB00B	11.5	8.0	12.0	3.0	0.7	59	1	Thin Type
FSRC150030RTB00B	15.6	13.6	3.0	1.85	0.7	25	1	Ultra Thin Type
FSRC150040RTB00B	15.6	13.6	4.0	1.85	0.7	28	1	Ultra Thin Type
FSRC150050RTB00B	15.6	13.6	5.0	1.85	0.7	29	1	Ultra Thin Type
FSRC150060RTB00B	15.6	13.6	6.0	1.85	0.7	30	1	Ultra Thin Type
FSRC160040RTB00T	15.6	13.6	4.0	2.8	0.7	26	1	Thin Type
FSRC171030RTB00T	17.0	13.6	3.0	2.8	0.7	26	1	Thin Type
FSRC171060RTB00T	17.0	13.6	6.0	2.8	0.7	37	1	Thin Type
FSRC171090RTB00T	17.0	13.6	9.0	2.8	0.7	44	1	Thin Type
FSRC171120RTB00T	17.0	13.6	12.0	2.8	0.7	53	1	Thin Type
FSRC200120RTB00T	20.0	16.0	12.0	3.0	0.8	60	1	Thin Type
FSRC222060RX000T	22.8	18.7	6.0	2.8	0.7	37	1	Thin Type
FSRC222090RX000T	22.8	18.7	9.0	2.8	0.7	46	1	Thin Type
FSRC222120RX000T	22.8	18.7	12.0	2.8	0.7	53	1	Thin Type
FSRC230060RTB00T	22.7	20.6	6.0	1.75	0.6	33	1	Ultra Thin Type
FSRC230090RTB00T	22.7	20.6	9.0	1.75	0.6	39	1	Ultra Thin Type
FSRC253060RT000T	25.0	21.0	6.0	3.0	0.8	41	1	Thin Type
FSRC253090RT000T	25.0	21.0	9.0	3.0	0.8	48	1	Thin Type
FSRC253120RT000T	25.0	21.0	12.0	3.0	0.8	56	1	Thin Type
FSRC280060RX000T	28.0	24.0	6.0	3.5	0.8	39	1	Thin Type
FSRC280090RX000T	28.0	24.0	9.0	3.5	0.8	46	1	Thin Type
FSRC280120RX000T	28.0	24.0	12.0	3.5	0.8	56	1	Thin Type
FSRC360060RX000T	36.0	32.0	6.0	3.5	0.8	40	1	Thin Type
FSRC360090RX000T	36.0	32.0	9.0	3.5	0.8	47	1	Thin Type
FSRC360120RX000T	36.0	32.0	12.0	3.5	0.8	56	1	Thin Type
FSRC420060RX000T	42.0	38.0	6.0	2.8	0.7	42	1	Thin Type
FSRC420090RX000T	42.0	38.0	9.0	2.8	0.7	48	1	Thin Type

Continued on the following page.

△Note • This PDF catalog is downloaded from the website of Murata Manufacturing co., ltd. Therefore, it's specifications are subject to change or our products in it may be discontinued without advance notice. Please check with our sales representatives or product engineers before ordering.
• This PDF catalog has only typical specifications because there is no space for detailed specifications. Therefore, please approve our product specifications or transact the approval sheet for product specifications before ordering.

Continued from the preceding page.

Part Number	A: Outer Dimension (mm)	B: Inner Dimension (mm)	H: Length Dimension (mm)	E: Width Dimension (mm)	C: Gap Dimension (mm)	Impedance at 100MHz (ohm)	Number of Turn	Note
FSRC420120RX000T	42.0	38.0	12.0	2.8	0.7	57	1	Thin Type

2

Noise Suppression Products/EMI Suppression Filters

● Standard Type

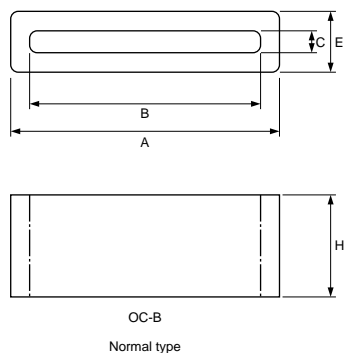

Part Number	A: Outer Dimension (mm)	B: Inner Dimension (mm)	H: Length Dimension (mm)	E: Width Dimension (mm)	C: Gap Dimension (mm)	Impedance at 100MHz (ohm)	Number of Turn	Note
FSRC140030RXB00T	13.8	9.6	3.0	5.0	0.8	30	1	-
FSRC140040RXB00T	13.8	9.6	4.0	5.0	0.8	36	1	-
FSRC140060RXB00T	13.8	9.6	6.0	5.0	0.8	44	1	-
FSRC140090RXB00T	13.8	9.6	9.0	5.0	0.8	66	1	-
FSRC140120RX000T	13.8	9.6	12.0	5.0	0.8	78	1	-
FSRC140200RXB00T	13.8	9.6	20.0	5.0	0.8	126	1	-
FSRC141060RXB00T	13.8	10.8	6.0	5.0	1.3	39	1	-
FSRC141120RXB00T	13.8	10.8	12.0	5.0	1.3	62	1	-
FSRC170030RTB00T	17.0	13.0	3.0	5.0	0.8	26	1	-
FSRC170060RTB00T	17.0	13.0	6.0	5.0	0.8	37	1	-
FSRC170090RTB00T	17.0	13.0	9.0	5.0	0.8	53	1	-
FSRC170120RT000T	17.0	13.0	12.0	5.0	0.8	75	1	-
FSRC170200RT000T	17.0	13.0	20.0	5.0	0.8	107	1	-
FSRC192060RTB00T	18.8	14.6	6.0	5.9	1.6	35	1	-
FSRC192090RTB00T	18.8	14.6	9.0	5.9	1.6	47	1	-
FSRC192120RTB00T	18.8	14.6	12.0	5.9	1.6	58	1	-
FSRC240150RX000T	23.8	18.8	15.0	6.3	1.1	76	1	-
FSRC250070RT000T	25.0	21.0	7.0	5.0	0.8	45	1	-
FSRC250120RT000T	25.0	21.0	12.0	5.0	0.8	70	1	-
FSRC252050RT000T	25.0	21.0	5.0	5.0	1.2	35	1	-
FSRC252060RT000T	25.0	21.0	6.0	5.0	1.2	39	1	-
FSRC252090RT000T	25.0	21.0	9.0	5.0	1.2	47	1	-
FSRC252120RT000T	25.0	21.0	12.0	5.0	1.2	55	1	-
FSRC260060RT000T	26.0	22.0	6.0	5.0	1.2	38	1	-
FSRC260090RT000T	26.0	22.0	9.0	5.0	1.2	49	1	-
FSRC271113RN000T	27.0	22.25	11.3	8.05	2.15	55	1	-
FSRC310060RN000T	31.0	27.0	6.0	5.0	0.8	47	1	-
FSRC310090RN000T	31.0	27.0	9.0	5.0	0.8	58	1	-
FSRC310120RN000T	31.0	27.0	12.0	5.0	0.8	70	1	-
FSRC310200RN000T	31.0	27.0	20.0	5.0	0.8	102	1	-
FSRC320080RT000T	32.0	27.8	8.0	6.5	1.3	45	1	-
FSRC320120RT000T	32.0	27.8	12.0	6.5	1.3	60	1	-
FSRC401120RT000T	40.0	35.0	12.0	4.5	1.0	65	1	-
FSRC410150RN000T	41.2	35.0	15.0	7.7	1.5	70	1	-
FSRC560120RT000T	56.2	52.2	12.0	4.8	0.9	70	1	-
FSRC580060RT000T	58.0	52.8	6.0	6.7	1.5	46	1	-

Continued on the following page.

Continued from the preceding page.

Part Number	A: Outer Dimension (mm)	B: Inner Dimension (mm)	H: Length Dimension (mm)	E: Width Dimension (mm)	C: Gap Dimension (mm)	Impedance at 100MHz (ohm)	Number of Turn	Note
FSRC580120RT000T	58.0	52.8	12.0	6.7	1.5	62	1	-
FSRC581180RTF00T	58.0	52.8	18.0	6.2	1.0	95	1	Division Type
FSRC600100RN000T	60.0	48.0	10.0	12.0	1.9	69	1	-
FSRC600127RN000T	60.0	48.0	12.7	12.0	1.9	72	1	-
FSRC800127RTF30T	80.0	68.6	12.7	10.0	2.6	71	1	Division Type

● Wide Type

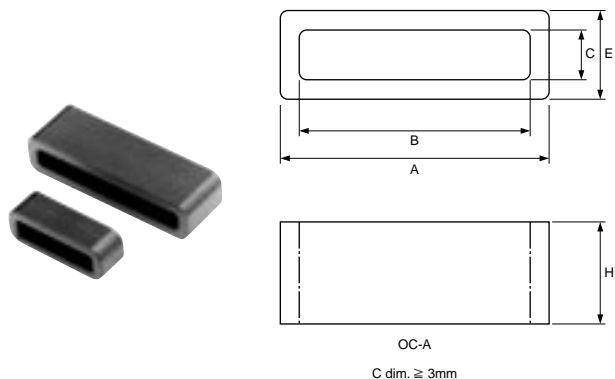

Part Number	A: Outer Dimension (mm)	B: Inner Dimension (mm)	H: Length Dimension (mm)	E: Width Dimension (mm)	C: Gap Dimension (mm)	Impedance at 100MHz (ohm)	Number of Turn	Note
FSRC142150RTB00T	14.0	9.0	15.0	9.0	4.0	90	1	Wide Type
FSRC190060RTB00T	19.0	15.0	6.0	7.0	3.5	34	1	Wide Type
FSRC191085RT000T	19.0	13.0	8.5	18.0	12.0	44	1	for USB Connector (Type B)
FSRC321100RN000T	32.0	28.0	10.0	7.5	3.5	35	1	Wide Type
FSRC321150RN000T	32.0	28.0	15.0	7.5	3.5	47	1	Wide Type
FSRC440100RN000T	44.0	40.0	10.0	7.5	3.8	34	1	Wide Type

Ferrite Core for EMI Suppression

Multi-hole Cores

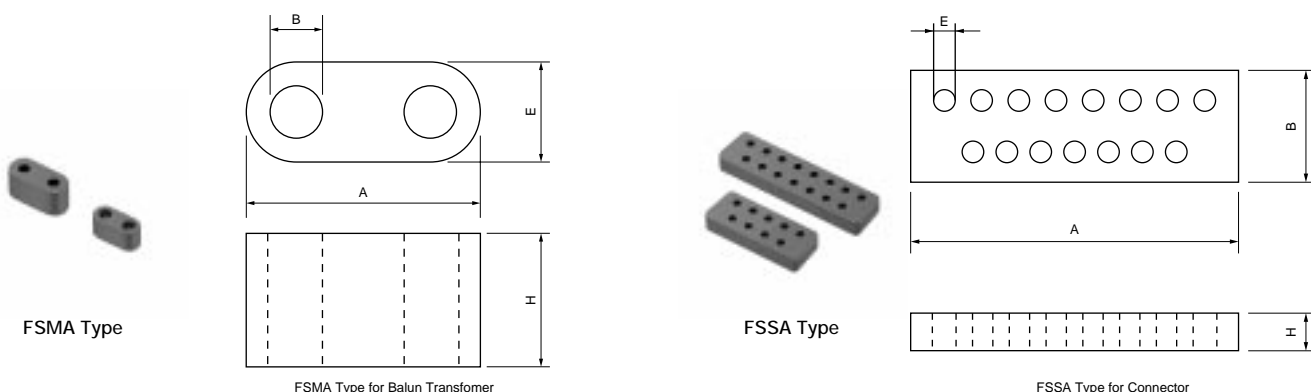

Part Number	A: Outer Dimension (mm)	B, E: Hole Dimension (mm)	H: Length Dimension (mm)	B, E: Width Dimension (mm)	Impedance at 100MHz (ohm)	Note
FSMA050020RLB00B	5.20	1.30	2.00	2.50	21	-
FSMA050020RTB00B	5.20	1.30	2.00	2.50	20	-
FSMA072020RLB00B	6.50	1.10	2.00	3.00	23	-
FSSA160025RN000T	16.0	1.15	2.5	6.4	43	for Connector
FSSA240025RN000T	24.0	1.15	2.5	6.4	45	for Connector

△Note • This PDF catalog is downloaded from the website of Murata Manufacturing co., ltd. Therefore, it's specifications are subject to change or our products in it may be discontinued without advance notice. Please check with our sales representatives or product engineers before ordering.
• This PDF catalog has only typical specifications because there is no space for detailed specifications. Therefore, please approve our product specifications or transact the approval sheet for product specifications before ordering.

Ferrite Core for EMI Suppression

Plate Cores

Noise Suppression Products/EMI Suppression Filters

2

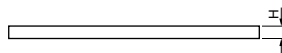
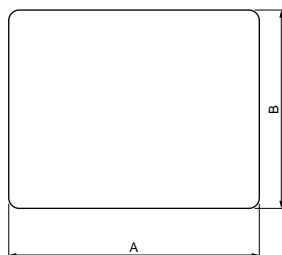

Part Number	A: Outer Dimension (mm)	B: Width Dimension (mm)	H: Thickness Dimension (mm)	Note
FSSA100008RN000T	10.0	10.0	0.8	-
FSSA100010RN000T	10.0	10.0	1.0	-
FSSA100Z55RN000T	10.0	10.0	0.55	-
FSSA101005RN000T	10.0	5.0	0.5	-
FSSA130004RN000T	13.0	5.0	0.4	-
FSSA150015RN000T	15.5	15.5	1.5	-
FSSA151005RN000T	15.0	5.0	0.5	-
FSSA190010RN000T	19.0	6.0	1.0	-
FSSA202010RN000T	20.0	16.5	1.0	-
FSSA202015RN000T	20.0	16.5	1.5	-
FSSA203005RN000T	20.0	20.0	0.5	-
FSSA203010RN000T	20.0	20.0	1.0	-
FSSA203015RN000T	20.0	20.0	1.5	-
FSSA205007RN000T	20.0	7.0	0.7	-
FSSA220007RN000T	22.0	7.0	0.7	-
FSSA222011RT000T	22.8	16.5	1.1	-
FSSA230008RN000T	23.0	23.0	0.8	-
FSSA230010RN000T	23.0	23.0	1.0	-
FSSA230015RN000T	23.0	23.0	1.5	-
FSSA250004RN000T	25.0	7.0	0.4	-
FSSA270010RN000T	27.0	20.0	1.0	-
FSSA271010RN000T	27.0	27.0	1.0	-
FSSA271020RN000T	27.0	27.0	2.0	-
FSSA271050RN000T	27.0	27.0	5.0	-
FSSA272010RN000T	27.0	15.0	1.0	-
FSSA290005RN000T	29.0	5.0	0.5	-
FSSA300010RN000T	30.0	30.0	1.0	-
FSSA401010RN000T	41.5	10.0	1.0	-
FSSA450015RT000T	45.0	10.0	1.5	-
FSSA530015RT000T	52.8	28.5	1.5	-
FSSA600020RN000T	60.5	30.6	2.0	-

Note • This PDF catalog is downloaded from the website of Murata Manufacturing co., Ltd. Therefore, it's specifications are subject to change or our products in it may be discontinued without advance notice. Please check with our sales representatives or product engineers before ordering.
 • This PDF catalog has only typical specifications because there is no space for detailed specifications. Therefore, please approve our product specifications or transact the approval sheet for product specifications before ordering.

Ferrite Core for EMI Suppression

Thin Type Sandwich Core

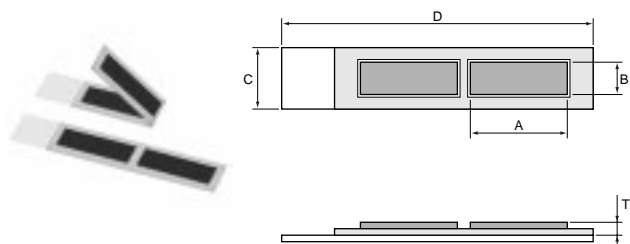

Part Number	A: Outer Dimension of Ferrite Core (mm)	B: Width Dimension (mm)	T: Thickness Dimension of Ferrite Core (mm)	C: Width of Adhesion Film (mm)	D: Length of Adhesion Film (mm)	Impedance at 100MHz (ohm)	Mass (g)	Note
FSSA101005RNN00S	10.0	5.0	0.5	9.5	35.0	28	0.28	-
FSSA101005RNN30S	10.0	5.0	0.5	9.5	35.0	28	0.28	Tape: UL510FR
FSSA151005RNN00S	15.0	5.0	0.5	9.5	45.0	28	0.43	-
FSSA151005RNN30S	15.0	5.0	0.5	9.5	45.0	28	0.43	Tape: UL510FR
FSSA205007RNN00S	20.0	7.0	0.7	13.5	55.0	34	0.98	-
FSSA205007RNN30S	20.0	7.0	0.7	13.5	55.0	34	0.98	Tape: UL510FR
FSSA220007RNN00S	22.0	7.0	0.7	11.5	59.0	35	1.17	-
FSSA220007RNN30S	22.0	7.0	0.7	11.5	59.0	35	1.17	Tape: UL510FR
FSSA290005RNN00S	29.0	5.0	0.5	9.5	73.0	29	0.79	-
FSSA290005RNN30S	29.0	5.0	0.5	9.5	73.0	29	0.79	Tape: UL510FR

3

Inductors (Coils)

Chip Inductor (Chip Coil)

Balun

Coupler

● Part Numbering

Chip Inductors (Chip Coils)

(Part Number)

LQ	H	32	M	N	331	K	2	3	L
①	②	③	④	⑤	⑥	⑦	⑧	⑨	⑩

- ① Product ID
- ② Structure
- ③ Dimensions (L×W)
- ④ Applications and Characteristics

Code	Series	Applications and Characteristics
H	LQG	Monolithic Air-core
N	LQM	for Resonant Circuit
D		for Choke (Low-current DC Power Supplies)
F	LQP	for Choke (DC Power Supplies)
M		Film Type
T	LQW	Film Type (Low DC Resistance Type)
A		High Q Type (UHF-SHF)
H	LQH	High Q Type (VHF-UHF)
N		for Resonant Circuit
M		for Resonant Circuit (Coating Type)
D		for Choke
C		for Choke (Coating Type)
S		for Choke (Magnetically Shielded Type)
H		for High-frequency Resonant Circuit
P		LQM/LQH

- ⑤ Category
- ⑥ Inductance

Expressed by three-digit alphanumerics. The unit is micro-henry (μH). The first and second figures are significant digits, and the third figure expresses the number of zeros which follow the two figures. If there is a decimal point, it is expressed by the capital letter "R". In this case, all figures are significant digits. If inductance is less than 0.1μH, the inductance code is expressed by a combination of two figures and the capital letter "N", and the unit of inductance is nano-henry (nH). The capital letter "N" indicates the unit of "nH", and also expresses a decimal point. In this case, all figures are significant digits.

- ⑦ Inductance Tolerance
- ⑧ Features (Except LQH□□P/LQM□□P)

Code	Features	Series
0	Standard Type	LQG/LQP/LQW/LQM*1/LQH*2
1	High-Q/ Low DC Resistance	LQW15A/18A/2BH
	Standard Type	LQM21N
2	Standard Type	LQH32C/32M
3	Low DC Resistance	LQH32C
5	Low Profile Type	LQH2MC/32C
7	Large Current Type	LQM21F
8	Low DC Resistance /Large Current Type	

*1 : Except LQM21N Series
*2 : Except LQH32 Series



⑨ Thickness (LQH□□P/LQM□□P only)

Code	Dimensions (T)
C	0.5mm
E	0.7mm
0	0.85mm
G	0.9mm
J	1.1mm
M	1.4mm
N	1.55mm
P	1.65mm
R	1.85mm

⑨ Electrode (Except LQH□□P/LQM□□P)

•Lead (Pb) Free

Code	Electrode	Series
0	Sn	LQG18H/LQP03T/LQW□□A/LQM
2		LQG15H/LQP□□T/□□M/LQH2MC
3	LF Solder	LQW□□H/LQH (Except LQH2MC)
4	Au	LQP03T

⑨ Specification (LQH□□P/LQM□□P only)

Code	Specification
0	Standard Type

⑩ Packaging

Micro Chip Transformer

(Part Number)

DX	P	18	B	N	75	14	T	L
①	②	③	④	⑤	⑥	⑦	⑧	⑨

- ① Product ID
- ② Structure
- ③ Dimensions (L×W)
- ④ Type of Transformer

Code	Type of Transformer
B	Balun
C	Coupler

- ⑤ Category
- ⑥ Port Impedance

Code	Port Impedance
50	50Ω
75	75Ω



⑦ Characteristics (Balun)

Code	Impedance Ratio
11	one to one
14	one to four

⑦ Characteristics (Coupler)

Code	Coupling Loss
10	10 dB
15	15 dB

⑧ Frequency Range

Code	Frequency Range
T	50MHz to 870MHz
H	470MHz to 702MHz
S	950MHz to 2150MHz

⑨ Packaging

Application	Part Number	Structure	Dimensions		Inductance Range (H)															
			(mm)	EIA Code	1n	10n	100n	1μ	10μ	100μ	1m	10m								
High Frequency Range	LQG15H	Multilayer	1.0 ±0.5	0402	1.0nH								270nH							
	LQG18H		1.6 ±0.8	0603	1.2nH									100nH						
	Tight Inductance Tolerance	LQP02T	Film	0.4 ±0.2	01005	0.4nH								18nH						
		LQP03T_00		0.6 ±0.3	0201	0.6nH									56nH					
		LQP03T_02		0.6 ±0.3	0201										68nH				120nH	
		LQP03T_04		0.6 ±0.3	0201	0.6nH									56nH					
		LQP15T		1.0 ±0.5	0402	1.0nH									18nH					
		LQP15M		1.0 ±0.5	0402	1.0nH									33nH					
		LQP18M		1.6 ±0.8	0603	1.3nH									100nH					
		LQW04A		Wire Wound (air core)	0.8 ±0.4	03015	1.1nH									33nH				
		LQW15A			1.0 ±0.5	0402	1.3nH									120nH				
		LQW18A			1.6 ±0.8	0603	2.2nH									470nH				
		LQW2BH			2.0 ±1.5	0805	2.7nH									470nH				
		LQW31H			3.2 ±1.6	1206	8.8nH									100nH				
		LQW21H		Wire Wound (ferrite core)	2.0 ±1.25	0805										0.47μH				2.2μH
		LQH31H			3.2 ±1.6	1206										54nH				880nH
		General Frequency Range		LQM18N	Magnetically Shielded Multilayer	1.6 ±0.8	0603									47nH				2200nH
LQM21N	2.0 ±1.25		0805											0.1μH				4.7μH		
LQH31M	Wire Wound (ferrite core)		3.2 ±1.6	1206										0.15μH				100μH		
LQH32M			3.2 ±2.5	1210										1.0μH				560μH		
LQH43M(N)			3.2 ±4.5	1812										1.0μH				2200μH		
DC-DC Converter Type	LQM21P	Magnetically Shielded Multilayer	2.0 ±1.25	0805										0.47μH				2.2μH		
	LQM2MP_G0		2.0 ±1.6	0806										0.47μH				4.7μH		
	LQM2HP_J0		2.5 ±2.0	1008										1.0μH				3.3μH		
	LQM2HP_G0		2.5 ±2.0	1008										0.47μH				4.7μH		
	LQM2HP_E0		2.5 ±2.0	1008										0.56μH						
	LQM31P_00		3.2 ±1.6	1206										0.47μH				4.7μH		
	LQM31P_C0		3.2 ±1.6	1206										0.47μH				2.2μH		
	LQH2MC_02		Wire Wound	2.0 ±1.6	0806										1.0μH				82μH	
	LQH2MC_52			2.0 ±1.6	0806										1.0μH				22μH	
	LQH3NP_M0			3.0 ±3.0	1212										1.0μH				100μH	
	LQH3NP_J0			3.0 ±3.0	1212										1.0μH				47μH	
	LQH3NP_G0			3.0 ±3.0	1212										1.0μH				250μH	
	LQH32P			3.2 ±2.5	1210										0.47μH				22μH	
	LQH44P			4.0 ±4.0	1515										1.0μH				22μH	
	LQH55P			5.87 ±5.2	2220										1.2μH				22μH	
Chokes	LQM18F	Magnetically Shielded Multilayer		1.6 ±0.8	0603									1.0μH				10μH		
	LQM21D			2.0 ±1.25	0805										1.0μH				47μH	
	LQM21F			2.0 ±1.25	0805										1.0μH				47μH	
	LQM31F	3.2 ±1.6		1206											10μH					
	LQH31C	Wire Wound		3.2 ±1.6	1206										0.12μH				100μH	
	LQH32C			3.2 ±2.5	1210										0.15μH				560μH	
	LQH32C_53			3.2 ±2.5	1210										1.0μH				100μH	
	LQH43C		3.2 ±4.5	1812										1.0μH				470μH		
	LQH55D		5.7 ±5.0	2220										0.12μH				10000μH		
	LQH66S		Magnetically Shielded	6.3 ±6.3	2525										0.27μH				10000μH	
	6.3 ±6.3			2525																

CAUTION : Use rosin-based flux, but not strong acidic flux (with chlorine content exceeding 0.2wt%) when soldering Chip Inductor (Chip Coil). Do not use water-soluble flux.

Note • This PDF catalog is downloaded from the website of Murata Manufacturing co., Ltd. Therefore, it's specifications are subject to change or our products in it may be discontinued without advance notice. Please check with our sales representatives or product engineers before ordering.
• This PDF catalog has only typical specifications because there is no space for detailed specifications. Therefore, please approve our product specifications or transact the approval sheet for product specifications before ordering.

Chip Inductor (Chip Coil)

for High Frequency Horizontal Wire Wound

● LQW04A Series (03015)

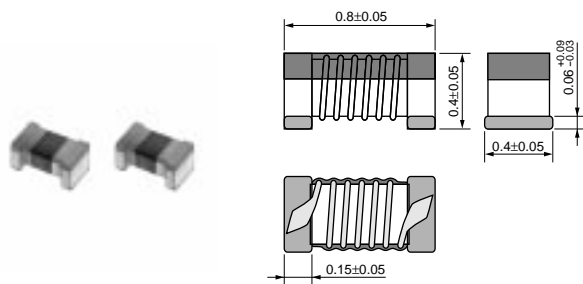

(in mm)

Part Number	Inductance (nH)	Test Frequency (MHz)	Rated Current (mA)	DC Resistance (ohm)	Q (min.)	Test Frequency (MHz)	Self Resonance Frequency (min.) (GHz)
LQW04AN1N1C00	1.1 ±0.2nH	100	990	0.03 max.	15	250	20.0
LQW04AN1N1D00	1.1 ±0.5nH	100	990	0.03 max.	15	250	20.0
LQW04AN1N8C00	1.8 ±0.2nH	100	700	0.06 max.	15	250	17.0
LQW04AN1N8D00	1.8 ±0.5nH	100	700	0.06 max.	15	250	17.0
LQW04AN2N7C00	2.7 ±0.2nH	100	570	0.07 max.	15	250	15.0
LQW04AN2N7D00	2.7 ±0.5nH	100	570	0.07 max.	15	250	15.0
LQW04AN3N0C00	3.0 ±0.2nH	100	620	0.07 max.	15	250	13.0
LQW04AN3N0D00	3.0 ±0.5nH	100	620	0.07 max.	15	250	13.0
LQW04AN3N6C00	3.6 ±0.2nH	100	530	0.10 max.	15	250	13.0
LQW04AN3N6D00	3.6 ±0.5nH	100	530	0.10 max.	15	250	13.0
LQW04AN3N9C00	3.9 ±0.2nH	100	530	0.10 max.	15	250	12.0
LQW04AN3N9D00	3.9 ±0.5nH	100	530	0.10 max.	15	250	12.0
LQW04AN4N3C00	4.3 ±0.2nH	100	530	0.10 max.	15	250	11.0
LQW04AN4N3D00	4.3 ±0.5nH	100	530	0.10 max.	15	250	11.0
LQW04AN4N7C00	4.7 ±0.2nH	100	440	0.14 max.	20	250	10.0
LQW04AN4N7D00	4.7 ±0.5nH	100	440	0.14 max.	20	250	10.0
LQW04AN5N1C00	5.1 ±0.2nH	100	470	0.12 max.	20	250	10.0
LQW04AN5N1D00	5.1 ±0.5nH	100	470	0.12 max.	20	250	10.0
LQW04AN5N6C00	5.6 ±0.2nH	100	470	0.12 max.	20	250	9.0
LQW04AN5N6D00	5.6 ±0.5nH	100	470	0.12 max.	20	250	9.0
LQW04AN6N2C00	6.2 ±0.2nH	100	390	0.19 max.	20	250	9.0
LQW04AN6N2D00	6.2 ±0.5nH	100	390	0.19 max.	20	250	9.0
LQW04AN6N8C00	6.8 ±0.2nH	100	440	0.14 max.	20	250	9.0
LQW04AN6N8D00	6.8 ±0.5nH	100	440	0.14 max.	20	250	9.0
LQW04AN7N5C00	7.5 ±0.2nH	100	440	0.14 max.	20	250	8.0
LQW04AN7N5D00	7.5 ±0.5nH	100	440	0.14 max.	20	250	8.0
LQW04AN8N2C00	8.2 ±0.2nH	100	350	0.23 max.	20	250	8.0
LQW04AN8N2D00	8.2 ±0.5nH	100	350	0.23 max.	20	250	8.0
LQW04AN9N1C00	9.1 ±0.2nH	100	400	0.16 max.	20	250	7.0
LQW04AN9N1D00	9.1 ±0.5nH	100	400	0.16 max.	20	250	7.0
LQW04AN10NH00	10 ±3%	100	330	0.26 max.	20	250	7.0
LQW04AN10NJ00	10 ±5%	100	330	0.26 max.	20	250	7.0
LQW04AN11NH00	11 ±3%	100	310	0.28 max.	15	250	7.0
LQW04AN11NJ00	11 ±5%	100	310	0.28 max.	15	250	7.0
LQW04AN12NH00	12 ±3%	100	310	0.28 max.	15	250	6.0
LQW04AN12NJ00	12 ±5%	100	310	0.28 max.	15	250	6.0
LQW04AN13NH00	13 ±3%	100	280	0.34 max.	15	250	6.0
LQW04AN13NJ00	13 ±5%	100	280	0.34 max.	15	250	6.0
LQW04AN15NH00	15 ±3%	100	240	0.48 max.	15	250	5.5

Continued on the following page.

△Note • This PDF catalog is downloaded from the website of Murata Manufacturing co., ltd. Therefore, it's specifications are subject to change or our products in it may be discontinued without advance notice. Please check with our sales representatives or product engineers before ordering.
• This PDF catalog has only typical specifications because there is no space for detailed specifications. Therefore, please approve our product specifications or transact the approval sheet for product specifications before ordering.

Continued from the preceding page.

Part Number	Inductance (nH)	Test Frequency (MHz)	Rated Current (mA)	DC Resistance (ohm)	Q (min.)	Test Frequency (MHz)	Self Resonance Frequency (min.) (GHz)
LQW04AN15NJ00	15 ±5%	100	240	0.48 max.	15	250	5.5
LQW04AN16NH00	16 ±3%	100	270	0.38 max.	15	250	5.5
LQW04AN16NJ00	16 ±5%	100	270	0.38 max.	15	250	5.5
LQW04AN18NH00	18 ±3%	100	220	0.54 max.	15	250	5.0
LQW04AN18NJ00	18 ±5%	100	220	0.54 max.	15	250	5.0
LQW04AN19NH00	19 ±3%	100	160	0.73 max.	15	250	5.0
LQW04AN19NJ00	19 ±5%	100	160	0.73 max.	15	250	5.0
LQW04AN20NH00	20 ±3%	100	210	0.56 max.	15	250	5.0
LQW04AN20NJ00	20 ±5%	100	210	0.56 max.	15	250	5.0
LQW04AN22NH00	22 ±3%	100	200	0.63 max.	15	250	5.0
LQW04AN22NJ00	22 ±5%	100	200	0.63 max.	15	250	5.0
LQW04AN23NH00	23 ±3%	100	160	0.95 max.	15	250	4.0
LQW04AN23NJ00	23 ±5%	100	160	0.95 max.	15	250	4.0
LQW04AN24NH00	24 ±3%	100	160	0.95 max.	15	250	4.0
LQW04AN24NJ00	24 ±5%	100	160	0.95 max.	15	250	4.0
LQW04AN25NH00	25 ±3%	100	160	0.95 max.	15	250	4.0
LQW04AN25NJ00	25 ±5%	100	160	0.95 max.	15	250	4.0
LQW04AN27NH00	27 ±3%	100	160	0.95 max.	15	250	4.0
LQW04AN27NJ00	27 ±5%	100	160	0.95 max.	15	250	4.0
LQW04AN33NH00	33 ±3%	100	140	1.11 max.	15	250	4.0
LQW04AN33NJ00	33 ±5%	100	140	1.11 max.	15	250	4.0

 Operating Temperature Range: -55 to +125°C
 Only for reflow soldering.

● LQW15A Series (0402)

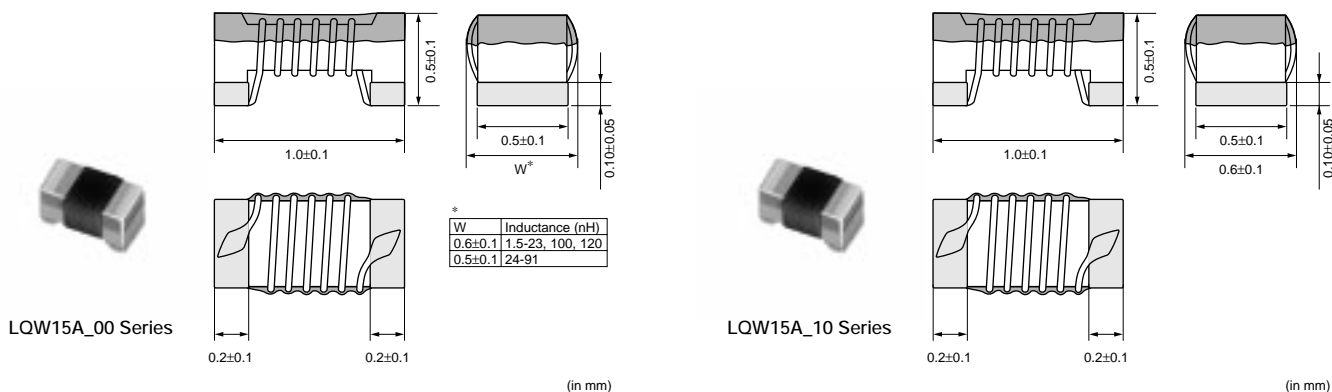

Part Number	Inductance (nH)	Test Frequency (MHz)	Rated Current (mA)	DC Resistance (ohm)	Q (min.)	Test Frequency (MHz)	Self Resonance Frequency (min.) (GHz)
LQW15AN1N5B00	1.5 ±0.1nH	100	1000	0.03 max.	10	250	18.0
LQW15AN1N5C00	1.5 ±0.2nH	100	1000	0.03 max.	10	250	18.0
LQW15AN1N5D00	1.5 ±0.5nH	100	1000	0.03 max.	10	250	18.0
LQW15AN2N4B00	2.4 ±0.1nH	100	850	0.05 max.	20	250	15.0
LQW15AN2N4C00	2.4 ±0.2nH	100	850	0.05 max.	20	250	15.0
LQW15AN2N4D00	2.4 ±0.5nH	100	850	0.05 max.	20	250	15.0
LQW15AN2N5B00	2.5 ±0.1nH	100	850	0.05 max.	20	250	15.0
LQW15AN2N5C00	2.5 ±0.2nH	100	850	0.05 max.	20	250	15.0
LQW15AN2N5D00	2.5 ±0.5nH	100	850	0.05 max.	20	250	15.0
LQW15AN2N7B00	2.7 ±0.1nH	100	850	0.05 max.	20	250	15.0
LQW15AN2N7C00	2.7 ±0.2nH	100	850	0.05 max.	20	250	15.0
LQW15AN2N7D00	2.7 ±0.5nH	100	850	0.05 max.	20	250	15.0
LQW15AN2N9B00	2.9 ±0.1nH	100	750	0.07 max.	20	250	15.0
LQW15AN2N9C00	2.9 ±0.2nH	100	750	0.07 max.	20	250	15.0

Continued on the following page.

 Continued from the preceding page.

Part Number	Inductance (nH)	Test Frequency (MHz)	Rated Current (mA)	DC Resistance (ohm)	Q (min.)	Test Frequency (MHz)	Self Resonance Frequency (min.) (GHz)
LQW15AN2N9D00	2.9 ±0.5nH	100	750	0.07 max.	20	250	15.0
LQW15AN3N9B00	3.9 ±0.1nH	100	750	0.07 max.	25	250	10.0
LQW15AN3N9C00	3.9 ±0.2nH	100	750	0.07 max.	25	250	10.0
LQW15AN3N9D00	3.9 ±0.5nH	100	750	0.07 max.	25	250	10.0
LQW15AN4N1B00	4.1 ±0.1nH	100	750	0.07 max.	25	250	10.0
LQW15AN4N1C00	4.1 ±0.2nH	100	750	0.07 max.	25	250	10.0
LQW15AN4N1D00	4.1 ±0.5nH	100	750	0.07 max.	25	250	10.0
LQW15AN4N3B00	4.3 ±0.1nH	100	750	0.07 max.	25	250	10.0
LQW15AN4N3C00	4.3 ±0.2nH	100	750	0.07 max.	25	250	10.0
LQW15AN4N3D00	4.3 ±0.5nH	100	750	0.07 max.	25	250	10.0
LQW15AN4N7B00	4.7 ±0.1nH	100	750	0.07 max.	25	250	8.0
LQW15AN4N7C00	4.7 ±0.2nH	100	750	0.07 max.	25	250	8.0
LQW15AN4N7D00	4.7 ±0.5nH	100	750	0.07 max.	25	250	8.0
LQW15AN5N1B00	5.1 ±0.1nH	100	600	0.12 max.	25	250	8.0
LQW15AN5N1C00	5.1 ±0.2nH	100	600	0.12 max.	25	250	8.0
LQW15AN5N1D00	5.1 ±0.5nH	100	600	0.12 max.	25	250	8.0
LQW15AN5N8B00	5.8 ±0.1nH	100	700	0.12 max.	25	250	8.0
LQW15AN5N8C00	5.8 ±0.2nH	100	700	0.12 max.	25	250	8.0
LQW15AN5N8D00	5.8 ±0.5nH	100	700	0.12 max.	25	250	8.0
LQW15AN6N2B00	6.2 ±0.1nH	100	700	0.09 max.	25	250	8.0
LQW15AN6N2C00	6.2 ±0.2nH	100	700	0.09 max.	25	250	8.0
LQW15AN6N2D00	6.2 ±0.5nH	100	700	0.09 max.	25	250	8.0
LQW15AN6N8G00	6.8 ±2%	100	700	0.09 max.	25	250	6.0
LQW15AN6N8H00	6.8 ±3%	100	700	0.09 max.	25	250	6.0
LQW15AN6N8J00	6.8 ±5%	100	700	0.09 max.	25	250	6.0
LQW15AN7N3G00	7.3 ±2%	100	570	0.13 max.	25	250	6.0
LQW15AN7N3H00	7.3 ±3%	100	570	0.13 max.	25	250	6.0
LQW15AN7N3J00	7.3 ±5%	100	570	0.13 max.	25	250	6.0
LQW15AN7N5G00	7.5 ±2%	100	570	0.13 max.	25	250	6.0
LQW15AN7N5H00	7.5 ±3%	100	570	0.13 max.	25	250	6.0
LQW15AN7N5J00	7.5 ±5%	100	570	0.13 max.	25	250	6.0
LQW15AN8N2G00	8.2 ±2%	100	540	0.14 max.	25	250	5.5
LQW15AN8N2H00	8.2 ±3%	100	540	0.14 max.	25	250	5.5
LQW15AN8N2J00	8.2 ±5%	100	540	0.14 max.	25	250	5.5
LQW15AN8N7G00	8.7 ±2%	100	540	0.14 max.	25	250	5.5
LQW15AN8N7H00	8.7 ±3%	100	540	0.14 max.	25	250	5.5
LQW15AN8N7J00	8.7 ±5%	100	540	0.14 max.	25	250	5.5
LQW15AN9N1G00	9.1 ±2%	100	540	0.14 max.	25	250	5.5
LQW15AN9N1H00	9.1 ±3%	100	540	0.14 max.	25	250	5.5
LQW15AN9N1J00	9.1 ±5%	100	540	0.14 max.	25	250	5.5
LQW15AN9N5G00	9.5 ±2%	100	540	0.14 max.	25	250	5.5
LQW15AN9N5H00	9.5 ±3%	100	540	0.14 max.	25	250	5.5
LQW15AN9N5J00	9.5 ±5%	100	540	0.14 max.	25	250	5.5
LQW15AN10NG00	10 ±2%	100	500	0.17 max.	25	250	5.5
LQW15AN10NH00	10 ±3%	100	500	0.17 max.	25	250	5.5
LQW15AN10NJ00	10 ±5%	100	500	0.17 max.	25	250	5.5
LQW15AN11NG00	11 ±2%	100	500	0.14 max.	30	250	5.5
LQW15AN11NH00	11 ±3%	100	500	0.14 max.	30	250	5.5
LQW15AN11NJ00	11 ±5%	100	500	0.14 max.	30	250	5.5
LQW15AN12NG00	12 ±2%	100	500	0.14 max.	30	250	5.5
LQW15AN12NH00	12 ±3%	100	500	0.14 max.	30	250	5.5
LQW15AN12NJ00	12 ±5%	100	500	0.14 max.	30	250	5.5
LQW15AN13NG00	13 ±2%	100	430	0.21 max.	25	250	5.0
LQW15AN13NH00	13 ±3%	100	430	0.21 max.	25	250	5.0
LQW15AN13NJ00	13 ±5%	100	430	0.21 max.	25	250	5.0

Continued on the following page. 

Note • This PDF catalog is downloaded from the website of Murata Manufacturing co., Ltd. Therefore, it's specifications are subject to change or our products in it may be discontinued without advance notice. Please check with our sales representatives or product engineers before ordering.
• This PDF catalog has only typical specifications because there is no space for detailed specifications. Therefore, please approve our product specifications or transact the approval sheet for product specifications before ordering.

Continued from the preceding page.

Part Number	Inductance (nH)	Test Frequency (MHz)	Rated Current (mA)	DC Resistance (ohm)	Q (min.)	Test Frequency (MHz)	Self Resonance Frequency (min.) (GHz)
LQW15AN15NG00	15 ±2%	100	460	0.16 max.	30	250	5.0
LQW15AN15NH00	15 ±3%	100	460	0.16 max.	30	250	5.0
LQW15AN15NJ00	15 ±5%	100	460	0.16 max.	30	250	5.0
LQW15AN16NG00	16 ±2%	100	370	0.24 max.	25	250	4.5
LQW15AN16NH00	16 ±3%	100	370	0.24 max.	25	250	4.5
LQW15AN16NJ00	16 ±5%	100	370	0.24 max.	25	250	4.5
LQW15AN18NG00	18 ±2%	100	370	0.27 max.	25	250	4.5
LQW15AN18NH00	18 ±3%	100	370	0.27 max.	25	250	4.5
LQW15AN18NJ00	18 ±5%	100	370	0.27 max.	25	250	4.5
LQW15AN19NG00	19 ±2%	100	370	0.27 max.	25	250	4.5
LQW15AN19NH00	19 ±3%	100	370	0.27 max.	25	250	4.5
LQW15AN19NJ00	19 ±5%	100	370	0.27 max.	25	250	4.5
LQW15AN20NG00	20 ±2%	100	370	0.27 max.	25	250	4.0
LQW15AN20NH00	20 ±3%	100	370	0.27 max.	25	250	4.0
LQW15AN20NJ00	20 ±5%	100	370	0.27 max.	25	250	4.0
LQW15AN22NG00	22 ±2%	100	310	0.30 max.	25	250	4.0
LQW15AN22NH00	22 ±3%	100	310	0.30 max.	25	250	4.0
LQW15AN22NJ00	22 ±5%	100	310	0.30 max.	25	250	4.0
LQW15AN23NG00	23 ±2%	100	310	0.30 max.	25	250	3.8
LQW15AN23NH00	23 ±3%	100	310	0.30 max.	25	250	3.8
LQW15AN23NJ00	23 ±5%	100	310	0.30 max.	25	250	3.8
LQW15AN24NG00	24 ±2%	100	280	0.52 max.	25	250	3.5
LQW15AN24NH00	24 ±3%	100	280	0.52 max.	25	250	3.5
LQW15AN24NJ00	24 ±5%	100	280	0.52 max.	25	250	3.5
LQW15AN27NG00	27 ±2%	100	280	0.52 max.	25	250	3.5
LQW15AN27NH00	27 ±3%	100	280	0.52 max.	25	250	3.5
LQW15AN27NJ00	27 ±5%	100	280	0.52 max.	25	250	3.5
LQW15AN30NG00	30 ±2%	100	270	0.58 max.	25	250	3.3
LQW15AN30NH00	30 ±3%	100	270	0.58 max.	25	250	3.3
LQW15AN30NJ00	30 ±5%	100	270	0.58 max.	25	250	3.3
LQW15AN33NG00	33 ±2%	100	260	0.63 max.	25	250	3.2
LQW15AN33NH00	33 ±3%	100	260	0.63 max.	25	250	3.2
LQW15AN33NJ00	33 ±5%	100	260	0.63 max.	25	250	3.2
LQW15AN36NG00	36 ±2%	100	260	0.63 max.	25	250	3.1
LQW15AN36NH00	36 ±3%	100	260	0.63 max.	25	250	3.1
LQW15AN36NJ00	36 ±5%	100	260	0.63 max.	25	250	3.1
LQW15AN39NG00	39 ±2%	100	250	0.70 max.	25	250	3.0
LQW15AN39NH00	39 ±3%	100	250	0.70 max.	25	250	3.0
LQW15AN39NJ00	39 ±5%	100	250	0.70 max.	25	250	3.0
LQW15AN40NG00	40 ±2%	100	250	0.70 max.	25	250	3.0
LQW15AN40NH00	40 ±3%	100	250	0.70 max.	25	250	3.0
LQW15AN40NJ00	40 ±5%	100	250	0.70 max.	25	250	3.0
LQW15AN43NG00	43 ±2%	100	250	0.70 max.	25	250	3.0
LQW15AN43NH00	43 ±3%	100	250	0.70 max.	25	250	3.0
LQW15AN43NJ00	43 ±5%	100	250	0.70 max.	25	250	3.0
LQW15AN47NG00	47 ±2%	100	210	1.08 max.	25	200	2.9
LQW15AN47NH00	47 ±3%	100	210	1.08 max.	25	200	2.9
LQW15AN47NJ00	47 ±5%	100	210	1.08 max.	25	200	2.9
LQW15AN51NG00	51 ±2%	100	210	1.08 max.	25	200	2.85
LQW15AN51NH00	51 ±3%	100	210	1.08 max.	25	200	2.85
LQW15AN51NJ00	51 ±5%	100	210	1.08 max.	25	200	2.85
LQW15AN56NG00	56 ±2%	100	200	1.17 max.	25	200	2.8
LQW15AN56NH00	56 ±3%	100	200	1.17 max.	25	200	2.8
LQW15AN56NJ00	56 ±5%	100	200	1.17 max.	25	200	2.8
LQW15AN62NG00	62 ±2%	100	145	1.82 max.	20	200	2.6

Continued on the following page.

Continued from the preceding page.

Part Number	Inductance (nH)	Test Frequency (MHz)	Rated Current (mA)	DC Resistance (ohm)	Q (min.)	Test Frequency (MHz)	Self Resonance Frequency (min.) (GHz)
LQW15AN62NH00	62 ±3%	100	145	1.82 max.	20	200	2.6
LQW15AN62NJ00	62 ±5%	100	145	1.82 max.	20	200	2.6
LQW15AN68NG00	68 ±2%	100	140	1.96 max.	20	200	2.5
LQW15AN68NJ00	68 ±5%	100	140	1.96 max.	20	200	2.5
LQW15AN72NG00	72 ±2%	100	135	2.10 max.	20	150	2.5
LQW15AN72NJ00	72 ±5%	100	135	2.10 max.	20	150	2.5
LQW15AN75NG00	75 ±2%	100	135	2.10 max.	20	150	2.4
LQW15AN75NJ00	75 ±5%	100	135	2.10 max.	20	150	2.4
LQW15AN82NG00	82 ±2%	100	130	2.24 max.	20	150	2.3
LQW15AN82NJ00	82 ±5%	100	130	2.24 max.	20	150	2.3
LQW15AN91NG00	91 ±2%	100	125	2.38 max.	20	150	2.1
LQW15AN91NJ00	91 ±5%	100	125	2.38 max.	20	150	2.1
LQW15ANR10J00	100 ±5%	100	120	2.52 max.	20	150	1.5
LQW15ANR12J00	120 ±5%	100	110	2.66 max.	20	150	1.0
LQW15AN1N3C10	1.3 ±0.2nH	100	1200	0.017 max.	20	250	16.0
LQW15AN1N3D10	1.3 ±0.5nH	100	1200	0.017 max.	20	250	16.0
LQW15AN2N2C10	2.2 ±0.2nH	100	1000	0.027 max.	25	250	14.0
LQW15AN2N2D10	2.2 ±0.5nH	100	1000	0.027 max.	25	250	14.0
LQW15AN2N4D10	2.4 ±0.5nH	100	1000	0.027 max.	25	250	14.0
LQW15AN3N3D10	3.3 ±0.5nH	100	900	0.040 max.	30	250	12.0
LQW15AN3N4C10	3.4 ±0.2nH	100	900	0.040 max.	30	250	12.0
LQW15AN3N4D10	3.4 ±0.5nH	100	900	0.040 max.	30	250	12.0
LQW15AN3N6C10	3.6 ±0.2nH	100	900	0.040 max.	30	250	9.5
LQW15AN3N6D10	3.6 ±0.5nH	100	900	0.040 max.	30	250	9.5
LQW15AN3N9D10	3.9 ±0.5nH	100	900	0.040 max.	30	250	7.0
LQW15AN4N7D10	4.7 ±0.5nH	100	800	0.051 max.	30	250	8.0
LQW15AN5N1C10	5.1 ±0.2nH	100	800	0.051 max.	30	250	8.0
LQW15AN5N1D10	5.1 ±0.5nH	100	800	0.051 max.	30	250	8.0
LQW15AN5N6C10	5.6 ±0.2nH	100	800	0.051 max.	30	250	8.0
LQW15AN5N6D10	5.6 ±0.5nH	100	800	0.051 max.	30	250	8.0

Operating Temperature Range: -55 to +125°C
Only for reflow soldering.

● LQW18A Series (0603)

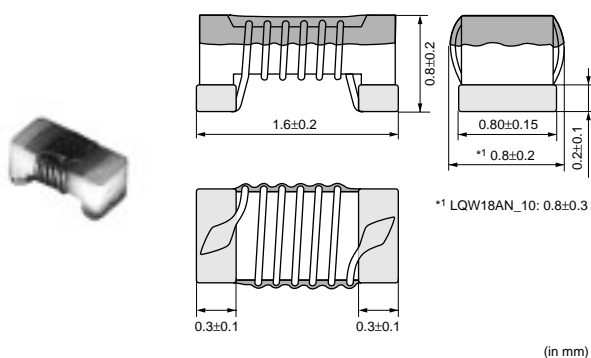

Part Number	Inductance (nH)	Test Frequency (MHz)	Rated Current (mA)	DC Resistance (ohm)	Q (min.)	Test Frequency (MHz)	Self Resonance Frequency (min.) (MHz)
LQW18AN2N2D00	2.2 ±0.5nH	100	700	0.049 max.	16	250	6000
LQW18AN3N6C00	3.6 ±0.2nH	100	850	0.059 max.	25	250	6000
LQW18AN3N6D00	3.6 ±0.5nH	100	850	0.059 max.	25	250	6000
LQW18AN3N9C00	3.9 ±0.2nH	100	850	0.059 max.	35	250	6000
LQW18AN3N9D00	3.9 ±0.5nH	100	850	0.059 max.	35	250	6000

Continued on the following page. ↗

△Note • This PDF catalog is downloaded from the website of Murata Manufacturing co., ltd. Therefore, it's specifications are subject to change or our products in it may be discontinued without advance notice. Please check with our sales representatives or product engineers before ordering.
• This PDF catalog has only typical specifications because there is no space for detailed specifications. Therefore, please approve our product specifications or transact the approval sheet for product specifications before ordering.

Continued from the preceding page.

Part Number	Inductance (nH)	Test Frequency (MHz)	Rated Current (mA)	DC Resistance (ohm)	Q (min.)	Test Frequency (MHz)	Self Resonance Frequency (min.) (MHz)
LQW18AN4N3C00	4.3 ±0.2nH	100	850	0.059 max.	35	250	6000
LQW18AN4N3D00	4.3 ±0.5nH	100	850	0.059 max.	35	250	6000
LQW18AN4N7D00	4.7 ±0.5nH	100	850	0.059 max.	35	250	6000
LQW18AN5N6C00	5.6 ±0.2nH	100	750	0.082 max.	35	250	6000
LQW18AN5N6D00	5.6 ±0.5nH	100	750	0.082 max.	35	250	6000
LQW18AN6N2C00	6.2 ±0.2nH	100	750	0.082 max.	35	250	6000
LQW18AN6N2D00	6.2 ±0.5nH	100	750	0.082 max.	35	250	6000
LQW18AN6N8C00	6.8 ±0.2nH	100	750	0.082 max.	35	250	6000
LQW18AN6N8D00	6.8 ±0.5nH	100	750	0.082 max.	35	250	6000
LQW18AN7N5D00	7.5 ±0.5nH	100	750	0.082 max.	35	250	6000
LQW18AN8N2D00	8.2 ±0.5nH	100	650	0.11 max.	35	250	6000
LQW18AN8N7D00	8.7 ±0.5nH	100	650	0.11 max.	35	250	6000
LQW18AN9N1D00	9.1 ±0.5nH	100	650	0.11 max.	35	250	6000
LQW18AN9N5D00	9.5 ±0.5nH	100	650	0.11 max.	35	250	6000
LQW18AN10NG00	10 ±2%	100	650	0.11 max.	35	250	6000
LQW18AN10NJ00	10 ±5%	100	650	0.11 max.	35	250	6000
LQW18AN11NG00	11 ±2%	100	650	0.11 max.	35	250	6000
LQW18AN11NJ00	11 ±5%	100	650	0.11 max.	35	250	6000
LQW18AN12NG00	12 ±2%	100	600	0.13 max.	35	250	6000
LQW18AN12NJ00	12 ±5%	100	600	0.13 max.	35	250	6000
LQW18AN13NG00	13 ±2%	100	600	0.13 max.	35	250	6000
LQW18AN13NJ00	13 ±5%	100	600	0.13 max.	35	250	6000
LQW18AN15NG00	15 ±2%	100	600	0.13 max.	40	250	6000
LQW18AN15NJ00	15 ±5%	100	600	0.13 max.	40	250	6000
LQW18AN16NG00	16 ±2%	100	550	0.16 max.	40	250	5500
LQW18AN16NJ00	16 ±5%	100	550	0.16 max.	40	250	5500
LQW18AN18NG00	18 ±2%	100	550	0.16 max.	40	250	5500
LQW18AN18NJ00	18 ±5%	100	550	0.16 max.	40	250	5500
LQW18AN20NG00	20 ±2%	100	550	0.16 max.	40	250	4900
LQW18AN20NJ00	20 ±5%	100	550	0.16 max.	40	250	4900
LQW18AN22NG00	22 ±2%	100	500	0.17 max.	40	250	4600
LQW18AN22NJ00	22 ±5%	100	500	0.17 max.	40	250	4600
LQW18AN24NG00	24 ±2%	100	500	0.21 max.	40	250	3800
LQW18AN24NJ00	24 ±5%	100	500	0.21 max.	40	250	3800
LQW18AN27NG00	27 ±2%	100	440	0.21 max.	40	250	3700
LQW18AN27NJ00	27 ±5%	100	440	0.21 max.	40	250	3700
LQW18AN30NG00	30 ±2%	100	420	0.23 max.	40	250	3300
LQW18AN30NJ00	30 ±5%	100	420	0.23 max.	40	250	3300
LQW18AN33NG00	33 ±2%	100	420	0.23 max.	40	250	3200
LQW18AN33NJ00	33 ±5%	100	420	0.23 max.	40	250	3200
LQW18AN36NG00	36 ±2%	100	400	0.26 max.	40	250	2900
LQW18AN36NJ00	36 ±5%	100	400	0.26 max.	40	250	2900
LQW18AN39NG00	39 ±2%	100	400	0.26 max.	40	250	2800
LQW18AN39NJ00	39 ±5%	100	400	0.26 max.	40	250	2800
LQW18AN43NG00	43 ±2%	100	380	0.29 max.	40	200	2700
LQW18AN43NJ00	43 ±5%	100	380	0.29 max.	40	200	2700
LQW18AN47NG00	47 ±2%	100	380	0.29 max.	38	200	2600
LQW18AN47NJ00	47 ±5%	100	380	0.29 max.	38	200	2600
LQW18AN51NG00	51 ±2%	100	370	0.33 max.	38	200	2500
LQW18AN51NJ00	51 ±5%	100	370	0.33 max.	38	200	2500
LQW18AN56NG00	56 ±2%	100	360	0.35 max.	38	200	2400
LQW18AN56NJ00	56 ±5%	100	360	0.35 max.	38	200	2400
LQW18AN62NG00	62 ±2%	100	280	0.51 max.	38	200	2300
LQW18AN62NJ00	62 ±5%	100	280	0.51 max.	38	200	2300
LQW18AN68NG00	68 ±2%	100	340	0.38 max.	38	200	2200

Continued on the following page.

Continued from the preceding page.

Part Number	Inductance (nH)	Test Frequency (MHz)	Rated Current (mA)	DC Resistance (ohm)	Q (min.)	Test Frequency (MHz)	Self Resonance Frequency (min.) (MHz)
LQW18AN68NJ00	68 ±5%	100	340	0.38 max.	38	200	2200
LQW18AN72NG00	72 ±2%	100	270	0.56 max.	34	150	2100
LQW18AN72NJ00	72 ±5%	100	270	0.56 max.	34	150	2100
LQW18AN75NG00	75 ±2%	100	270	0.56 max.	34	150	2050
LQW18AN75NJ00	75 ±5%	100	270	0.56 max.	34	150	2050
LQW18AN82NG00	82 ±2%	100	250	0.60 max.	34	150	2000
LQW18AN82NJ00	82 ±5%	100	250	0.60 max.	34	150	2000
LQW18AN91NG00	91 ±2%	100	230	0.64 max.	34	150	1900
LQW18AN91NJ00	91 ±5%	100	230	0.64 max.	34	150	1900
LQW18ANR10G00	100 ±2%	100	220	0.68 max.	34	150	1800
LQW18ANR10J00	100 ±5%	100	220	0.68 max.	34	150	1800
LQW18ANR11G00	110 ±2%	100	200	1.2 max.	32	150	1700
LQW18ANR11J00	110 ±5%	100	200	1.2 max.	32	150	1700
LQW18ANR12G00	120 ±2%	100	180	1.3 max.	32	150	1600
LQW18ANR12J00	120 ±5%	100	180	1.3 max.	32	150	1600
LQW18ANR13G00	130 ±2%	100	170	1.4 max.	32	150	1450
LQW18ANR13J00	130 ±5%	100	170	1.4 max.	32	150	1450
LQW18ANR15G00	150 ±2%	100	160	1.5 max.	32	150	1400
LQW18ANR15J00	150 ±5%	100	160	1.5 max.	32	150	1400
LQW18ANR16G00	160 ±2%	100	150	2.1 max.	32	150	1350
LQW18ANR16J00	160 ±5%	100	150	2.1 max.	32	150	1350
LQW18ANR18G00	180 ±2%	100	140	2.2 max.	25	100	1300
LQW18ANR18J00	180 ±5%	100	140	2.2 max.	25	100	1300
LQW18ANR20G00	200 ±2%	100	120	2.4 max.	25	100	1250
LQW18ANR20J00	200 ±5%	100	120	2.4 max.	25	100	1250
LQW18ANR22G00	220 ±2%	100	120	2.5 max.	25	100	1200
LQW18ANR22J00	220 ±5%	100	120	2.5 max.	25	100	1200
LQW18ANR27G00	270 ±2%	100	110	3.4 max.	30	100	960
LQW18ANR27J00	270 ±5%	100	110	3.4 max.	30	100	960
LQW18ANR33G00	330 ±2%	100	85	5.5 max.	30	100	800
LQW18ANR33J00	330 ±5%	100	85	5.5 max.	30	100	800
LQW18ANR39G00	390 ±2%	100	80	6.2 max.	30	100	800
LQW18ANR39J00	390 ±5%	100	80	6.2 max.	30	100	800
LQW18ANR47G00	470 ±2%	100	75	7.0 max.	30	100	700
LQW18ANR47J00	470 ±5%	100	75	7.0 max.	30	100	700
LQW18AN2N2D10	2.2 ±0.5nH	100	1400	0.018 max.	25	250	18000
LQW18AN3N9C10	3.9 ±0.2nH	100	1000	0.032 max.	38	250	11000
LQW18AN3N9D10	3.9 ±0.5nH	100	1000	0.032 max.	38	250	11000
LQW18AN5N6D10	5.6 ±0.5nH	100	900	0.045 max.	38	250	10000
LQW18AN6N8C10	6.8 ±0.2nH	100	900	0.045 max.	38	250	7000
LQW18AN6N8D10	6.8 ±0.5nH	100	900	0.045 max.	38	250	7000
LQW18AN8N2D10	8.2 ±0.5nH	100	800	0.058 max.	38	250	7000
LQW18AN10NG10	10 ±2%	100	800	0.058 max.	38	250	5000
LQW18AN10NJ10	10 ±5%	100	800	0.058 max.	38	250	5000
LQW18AN12NG10	12 ±2%	100	750	0.071 max.	38	250	5000
LQW18AN12NJ10	12 ±5%	100	750	0.071 max.	38	250	5000
LQW18AN15NJ10	15 ±5%	100	700	0.085 max.	42	250	4500
LQW18AN18NG10	18 ±2%	100	700	0.085 max.	42	250	3500
LQW18AN18NJ10	18 ±5%	100	700	0.085 max.	42	250	3500
LQW18AN22NG10	22 ±2%	100	640	0.099 max.	42	250	3200
LQW18AN22NJ10	22 ±5%	100	640	0.099 max.	42	250	3200
LQW18AN27NG10	27 ±2%	100	590	0.116 max.	42	250	2800
LQW18AN27NJ10	27 ±5%	100	590	0.116 max.	42	250	2800
LQW18AN33NJ10	33 ±5%	100	550	0.132 max.	42	250	2500

Operating Temperature Range: -55 to +125°C

Only for reflow soldering.

△Note • This PDF catalog is downloaded from the website of Murata Manufacturing co., ltd. Therefore, it's specifications are subject to change or our products in it may be discontinued without advance notice. Please check with our sales representatives or product engineers before ordering.
• This PDF catalog has only typical specifications because there is no space for detailed specifications. Therefore, please approve our product specifications or transact the approval sheet for product specifications before ordering.

Chip Inductor (Chip Coil)

for High Frequency Vertical Wire Wound

● LQW2BH Series (0805)

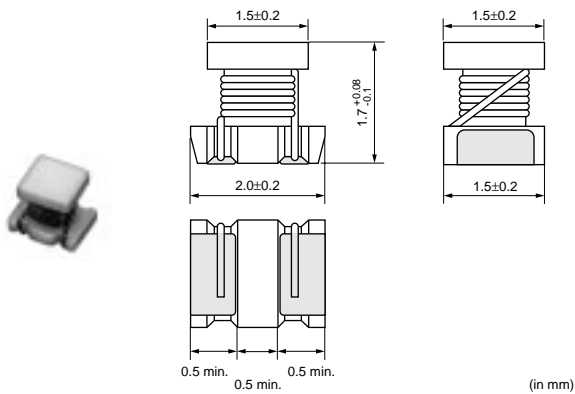

(in mm)

Part Number	Inductance (nH)	Test Frequency (MHz)	Rated Current (mA)	DC Resistance (ohm)	Q (min.)	Test Frequency (MHz)	Self Resonance Frequency (min.) (MHz)
LQW2BHN3N3D03	3.3 ±0.5nH	100	910	0.05 max.	10	250	6000
LQW2BHN6N8D03	6.8 ±0.5nH	100	680	0.11 max.	20	250	5400
LQW2BHN8N2D03	8.2 ±0.5nH	100	630	0.12 max.	20	250	3900
LQW2BHN10NJ03	10 ±5%	100	1320	0.03 max.	30	250	3300
LQW2BHN12NJ03	12 ±5%	100	680	0.11 max.	30	250	3200
LQW2BHN15NJ03	15 ±5%	100	630	0.12 max.	30	250	2700
LQW2BHN18NJ03	18 ±5%	100	690	0.10 max.	30	250	2600
LQW2BHN22NJ03	22 ±5%	100	720	0.09 max.	30	250	2100
LQW2BHN27NJ03	27 ±5%	100	540	0.17 max.	40	250	2300
LQW2BHN33NG03	33 ±2%	100	570	0.15 max.	40	250	1900
LQW2BHN33NJ03	33 ±5%	100	570	0.15 max.	40	250	1900
LQW2BHN39NG03	39 ±2%	100	730	0.09 max.	40	250	1700
LQW2BHN39NJ03	39 ±5%	100	730	0.09 max.	40	250	1700
LQW2BHN47NG03	47 ±2%	100	450	0.23 max.	40	200	1600
LQW2BHN47NJ03	47 ±5%	100	450	0.23 max.	40	200	1600
LQW2BHN56NG03	56 ±2%	100	430	0.26 max.	40	200	1500
LQW2BHN56NJ03	56 ±5%	100	430	0.26 max.	40	200	1500
LQW2BHN68NG03	68 ±2%	100	460	0.23 max.	40	200	1200
LQW2BHN68NJ03	68 ±5%	100	460	0.23 max.	40	200	1200
LQW2BHN82NG03	82 ±2%	100	320	0.42 max.	40	150	1100
LQW2BHN82NJ03	82 ±5%	100	320	0.42 max.	40	150	1100
LQW2BHNR10G03	100 ±2%	100	270	0.55 max.	35	150	900
LQW2BHNR10J03	100 ±5%	100	350	0.38 max.	40	150	900
LQW2BHNR12G03	120 ±2%	100	320	0.40 max.	40	150	750
LQW2BHNR12J03	120 ±5%	100	320	0.40 max.	40	150	750
LQW2BHNR15G03	150 ±2%	100	260	0.68 max.	30	150	350
LQW2BHNR15J03	150 ±5%	100	390	0.47 max.	30	150	350
LQW2BHNR18G03	180 ±2%	100	250	0.71 max.	35	100	700
LQW2BHNR18J03	180 ±5%	100	250	0.71 max.	35	100	700
LQW2BHNR22G03	220 ±2%	100	240	0.70 max.	35	100	500
LQW2BHNR22J03	220 ±5%	100	240	0.70 max.	35	100	500
LQW2BHNR27J03	270 ±5%	10	190	2.00 max.	15	25.5	550
LQW2BHNR27K03	270 ±10%	10	190	2.00 max.	15	25.5	550
LQW2BHNR33J03	330 ±5%	10	180	2.20 max.	15	25.5	500
LQW2BHNR33K03	330 ±10%	10	180	2.20 max.	15	25.5	500
LQW2BHNR39J03	390 ±5%	10	170	2.50 max.	15	25.5	400
LQW2BHNR39K03	390 ±10%	10	170	2.50 max.	15	25.5	400
LQW2BHNR47J03	470 ±5%	10	160	2.80 max.	15	25.5	350
LQW2BHNR47K03	470 ±10%	10	160	2.80 max.	15	25.5	350

Continued on the following page.

Continued from the preceding page.

Part Number	Inductance (nH)	Test Frequency (MHz)	Rated Current (mA)	DC Resistance (ohm)	Q (min.)	Test Frequency (MHz)	Self Resonance Frequency (min.) (MHz)
LQW2BHN2N7D13	2.7 ±0.5nH	100	1900	0.02 max.	20	250	6000
LQW2BHN3N1D13	3.1 ±0.5nH	100	1800	0.02 max.	20	250	6000
LQW2BHN3N3D13	3.3 ±0.5nH	100	1700	0.02 max.	20	250	6000
LQW2BHN5N6D13	5.6 ±0.5nH	100	1500	0.02 max.	35	250	6000
LQW2BHN6N8D13	6.8 ±0.5nH	100	1400	0.02 max.	35	250	5400
LQW2BHN8N6D13	8.6 ±0.5nH	100	1300	0.03 max.	35	250	3900
LQW2BHN10NJ13	10 ±5%	100	1320	0.03 max.	35	250	3300
LQW2BHN12NK13	12 ±10%	100	1100	0.04 max.	40	250	3200
LQW2BHN15NK13	15 ±10%	100	1000	0.04 max.	40	250	3100
LQW2BHN18NK13	18.8 ±10%	100	1000	0.05 max.	40	250	2600
LQW2BHN21NK13	21 ±10%	100	950	0.05 max.	40	250	2200
LQW2BHN27NK13	27 ±10%	100	900	0.06 max.	40	250	1800

Operating Temperature Range: -40 to +85°C

● LQW31H Series (1206)

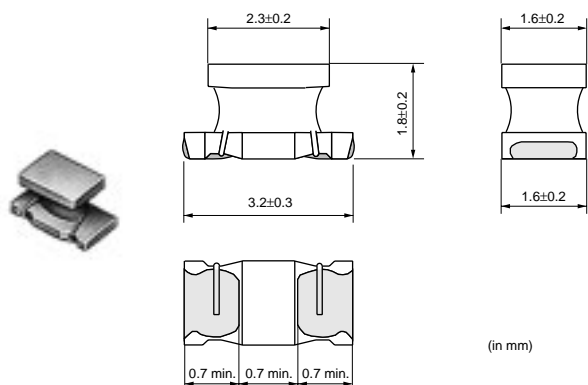

Part Number	Inductance (nH)	Test Frequency (MHz)	Rated Current (mA)	DC Resistance (ohm)	Q (min.)	Test Frequency (MHz)	Self Resonance Frequency (min.) (MHz)
LQW31HN8N8J03	8.8 ±5%	100	750	0.029 ±40%	50	436	1000
LQW31HN8N8K03	8.8 ±10%	100	750	0.029 ±40%	50	436	1000
LQW31HN15NJ03	14.7 ±5%	100	680	0.035 ±40%	60	436	1000
LQW31HN15NK03	14.7 ±10%	100	680	0.035 ±40%	60	436	1000
LQW31HN17NJ03	17 ±5%	100	650	0.037 ±40%	60	436	1000
LQW31HN17NK03	17 ±10%	100	650	0.037 ±40%	60	436	1000
LQW31HN23NJ03	23 ±5%	100	590	0.046 ±40%	60	436	1000
LQW31HN23NK03	23 ±10%	100	590	0.046 ±40%	60	436	1000
LQW31HN27NJ03	27 ±5%	100	560	0.051 ±40%	60	436	1000
LQW31HN27NK03	27 ±10%	100	560	0.051 ±40%	60	436	1000
LQW31HN33NJ03	33 ±5%	100	530	0.057 ±40%	60	436	1000
LQW31HN33NK03	33 ±10%	100	530	0.057 ±40%	60	436	1000
LQW31HN39NJ03	39 ±5%	100	490	0.067 ±40%	60	436	1000
LQW31HN39NK03	39 ±10%	100	490	0.067 ±40%	60	436	1000
LQW31HN47NJ03	47 ±5%	100	380	0.11 ±40%	60	436	1000
LQW31HN47NK03	47 ±10%	100	380	0.11 ±40%	60	436	1000
LQW31HN56NJ03	56 ±5%	100	330	0.14 ±40%	60	436	1000
LQW31HN56NK03	56 ±10%	100	330	0.14 ±40%	60	436	1000
LQW31HN64NJ03	64 ±5%	100	290	0.18 ±40%	60	436	1000
LQW31HN64NK03	64 ±10%	100	290	0.18 ±40%	60	436	1000
LQW31HN84NJ03	84 ±5%	100	240	0.28 ±40%	60	436	1000
LQW31HN84NK03	84 ±10%	100	240	0.28 ±40%	60	436	1000
LQW31HNR10J03	100 ±5%	100	230	0.3 ±40%	60	436	900
LQW31HNR10K03	100 ±10%	100	230	0.3 ±40%	60	436	900

Operating Temperature Range: -40 to +85°C

△Note • This PDF catalog is downloaded from the website of Murata Manufacturing co., ltd. Therefore, it's specifications are subject to change or our products in it may be discontinued without advance notice. Please check with our sales representatives or product engineers before ordering.
• This PDF catalog has only typical specifications because there is no space for detailed specifications. Therefore, please approve our product specifications or transact the approval sheet for product specifications before ordering.

Chip Inductor (Chip Coil)

for High Frequency Horizontal Wire Wound Ferrite Type

● LQW21H Series (0805)

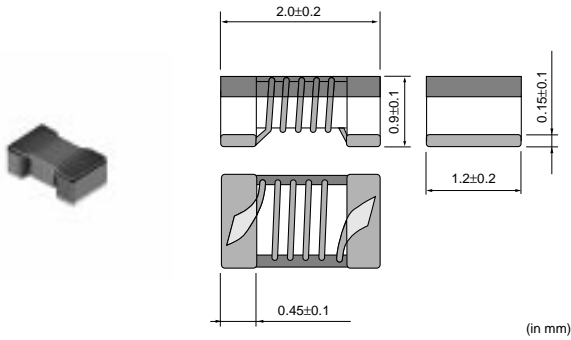

Part Number	Inductance (μH)	Test Frequency (MHz)	Rated Current (mA)	DC Resistance (ohm)	Q (min.)	Test Frequency (MHz)	Self Resonance Frequency (min.) (MHz)
LQW21HNR47J00	0.47 ±5%	10	160	1.30 max.	35	100	620
LQW21HNR56J00	0.56 ±5%	10	150	1.43 max.	35	100	580
LQW21HNR68J00	0.68 ±5%	10	130	2.21 max.	35	100	520
LQW21HNR82J00	0.82 ±5%	10	125	2.34 max.	35	100	480
LQW21HN1R0J00	1.0 ±5%	10	115	2.86 max.	35	100	450
LQW21HN1R2J00	1.2 ±5%	10	100	3.12 max.	35	100	400
LQW21HN1R5J00	1.5 ±5%	10	85	5.33 max.	35	100	350
LQW21HN1R8J00	1.8 ±5%	10	80	5.85 max.	35	100	320
LQW21HN2R2J00	2.2 ±5%	10	75	6.50 max.	35	100	300

Operating Temperature Range: -40 to +85°C
Only for reflow soldering.

Chip Inductor (Chip Coil)

for High Frequency Vertical Wire Wound Ferrite Type

● LQH31H Series (1206)

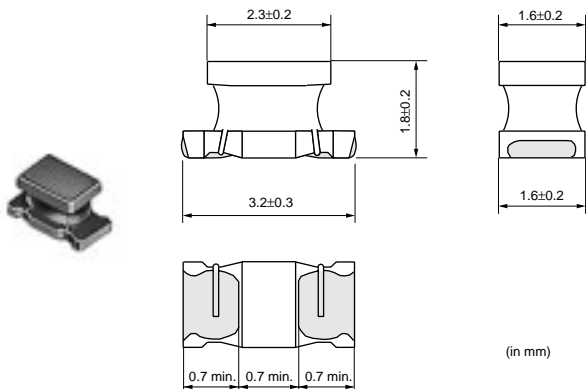

Part Number	Inductance (nH)	Test Frequency (MHz)	Rated Current (mA)	DC Resistance (ohm)	Q (min.)	Test Frequency (MHz)	Self Resonance Frequency (min.) (MHz)
LQH31HN54NK03	54 ±10%	1	920	0.035 ±30%	50	100	800
LQH31HN95NK03	95 ±10%	1	790	0.047 ±30%	60	100	650
LQH31HNR14J03	145 ±5%	1	700	0.061 ±30%	60	100	500
LQH31HNR14K03	145 ±10%	1	700	0.061 ±30%	60	100	500
LQH31HNR21J03	215 ±5%	1	520	0.11 ±30%	60	100	430
LQH31HNR21K03	215 ±10%	1	520	0.11 ±30%	60	100	430

Continued on the following page.

Note • This PDF catalog is downloaded from the website of Murata Manufacturing co., Ltd. Therefore, it's specifications are subject to change or our products in it may be discontinued without advance notice. Please check with our sales representatives or product engineers before ordering.
• This PDF catalog has only typical specifications because there is no space for detailed specifications. Therefore, please approve our product specifications or transact the approval sheet for product specifications before ordering.

Continued from the preceding page.

Part Number	Inductance (nH)	Test Frequency (MHz)	Rated Current (mA)	DC Resistance (ohm)	Q (min.)	Test Frequency (MHz)	Self Resonance Frequency (min.) (MHz)
LQH31HNR29J03	290 ±5%	1	420	0.17 ±30%	60	100	360
LQH31HNR29K03	290 ±10%	1	420	0.17 ±30%	60	100	360
LQH31HNR39J03	390 ±5%	1	330	0.26 ±30%	60	100	300
LQH31HNR39K03	390 ±10%	1	330	0.26 ±30%	60	100	300
LQH31HNR50J03	500 ±5%	1	260	0.44 ±30%	60	100	270
LQH31HNR50K03	500 ±10%	1	260	0.44 ±30%	60	100	270
LQH31HNR61J03	610 ±5%	1	250	0.48 ±30%	60	100	240
LQH31HNR61K03	610 ±10%	1	250	0.48 ±30%	60	100	240
LQH31HNR75J03	750 ±5%	1	190	0.79 ±30%	60	100	220
LQH31HNR75K03	750 ±10%	1	190	0.79 ±30%	60	100	220
LQH31HNR88J03	880 ±5%	1	180	0.86 ±30%	60	100	200
LQH31HNR88K03	880 ±10%	1	180	0.86 ±30%	60	100	200

Operating Temperature Range: -40 to +85°C

Chip Inductor (Chip Coil)

for High Frequency Multilayer Type

● LQG15HN Series (0402)

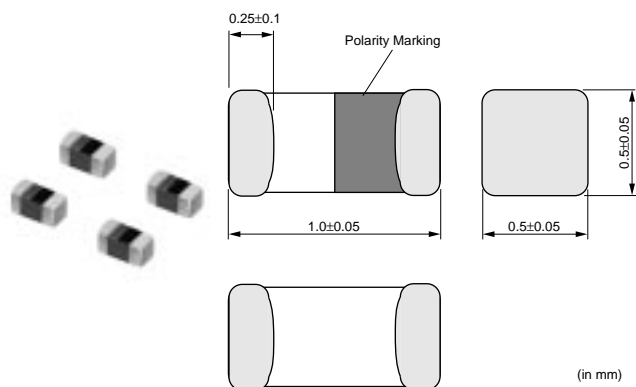

Part Number	Inductance (nH)	Test Frequency (MHz)	Rated Current (mA)	DC Resistance (ohm)	Q (min.)	Test Frequency (MHz)	Self Resonance Frequency (min.) (MHz)
LQG15HN1N0S02	1.0 ±0.3nH	100	300	0.10 max.	8	100	6000
LQG15HN1N1S02	1.1 ±0.3nH	100	300	0.10 max.	8	100	6000
LQG15HN1N2S02	1.2 ±0.3nH	100	300	0.10 max.	8	100	6000
LQG15HN1N3S02	1.3 ±0.3nH	100	300	0.10 max.	8	100	6000
LQG15HN1N5S02	1.5 ±0.3nH	100	300	0.10 max.	8	100	6000
LQG15HN1N6S02	1.6 ±0.3nH	100	300	0.10 max.	8	100	6000
LQG15HN1N8S02	1.8 ±0.3nH	100	300	0.10 max.	8	100	6000
LQG15HN2N0S02	2.0 ±0.3nH	100	300	0.12 max.	8	100	6000
LQG15HN2N2S02	2.2 ±0.3nH	100	300	0.15 max.	8	100	6000
LQG15HN2N4S02	2.4 ±0.3nH	100	300	0.16 max.	8	100	6000
LQG15HN2N7S02	2.7 ±0.3nH	100	300	0.17 max.	8	100	6000
LQG15HN3N0S02	3.0 ±0.3nH	100	300	0.18 max.	8	100	6000
LQG15HN3N3S02	3.3 ±0.3nH	100	300	0.19 max.	8	100	6000
LQG15HN3N6S02	3.6 ±0.3nH	100	300	0.19 max.	8	100	6000
LQG15HN3N9S02	3.9 ±0.3nH	100	300	0.19 max.	8	100	6000
LQG15HN4N3S02	4.3 ±0.3nH	100	300	0.21 max.	8	100	6000
LQG15HN4N7S02	4.7 ±0.3nH	100	300	0.23 max.	8	100	6000
LQG15HN5N1S02	5.1 ±0.3nH	100	300	0.24 max.	8	100	6000
LQG15HN5N6S02	5.6 ±0.3nH	100	300	0.26 max.	8	100	5300
LQG15HN6N2S02	6.2 ±0.3nH	100	300	0.27 max.	8	100	4300

Continued on the following page. ↗

△Note • This PDF catalog is downloaded from the website of Murata Manufacturing co., ltd. Therefore, it's specifications are subject to change or our products in it may be discontinued without advance notice. Please check with our sales representatives or product engineers before ordering.
• This PDF catalog has only typical specifications because there is no space for detailed specifications. Therefore, please approve our product specifications or transact the approval sheet for product specifications before ordering.

Continued from the preceding page.

Part Number	Inductance (nH)	Test Frequency (MHz)	Rated Current (mA)	DC Resistance (ohm)	Q (min.)	Test Frequency (MHz)	Self Resonance Frequency (min.) (MHz)
LQG15HN6N8J02	6.8 ±5%	100	300	0.29 max.	8	100	4200
LQG15HN7N5J02	7.5 ±5%	100	300	0.31 max.	8	100	3900
LQG15HN8N2J02	8.2 ±5%	100	300	0.33 max.	8	100	3600
LQG15HN9N1J02	9.1 ±5%	100	300	0.34 max.	8	100	3400
LQG15HN10NJ02	10 ±5%	100	300	0.35 max.	8	100	3200
LQG15HN12NJ02	12 ±5%	100	300	0.41 max.	8	100	2800
LQG15HN15NJ02	15 ±5%	100	300	0.46 max.	8	100	2300
LQG15HN18NJ02	18 ±5%	100	300	0.51 max.	8	100	2100
LQG15HN22NJ02	22 ±5%	100	300	0.58 max.	8	100	1800
LQG15HN27NJ02	27 ±5%	100	300	0.67 max.	8	100	1600
LQG15HN33NJ02	33 ±5%	100	200	0.67 max.	8	100	1500
LQG15HN39NJ02	39 ±5%	100	200	1.06 max.	8	100	1200
LQG15HN47NJ02	47 ±5%	100	200	1.15 max.	8	100	1000
LQG15HN56NJ02	56 ±5%	100	200	1.20 max.	8	100	800
LQG15HN68NJ02	68 ±5%	100	180	1.25 max.	8	100	800
LQG15HN82NJ02	82 ±5%	100	150	1.60 max.	8	100	600
LQG15HNR10J02	100 ±5%	100	150	1.60 max.	8	100	600
LQG15HNR12J02	120 ±5%	100	150	1.60 max.	8	100	600

 Operating Temperature Range: -55 to +125°C
 Only for reflow soldering.

● LQG15HS Series (0402)

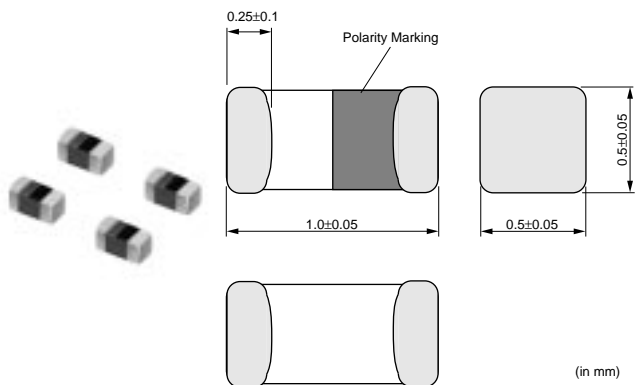

Part Number	Inductance (nH)	Test Frequency (MHz)	Rated Current (mA)	DC Resistance (ohm)	Q (min.)	Test Frequency (MHz)	Self Resonance Frequency (min.) (MHz)
LQG15HS1N0S02	1.0 ±0.3nH	100	300	0.07 max.	8	100	10000
LQG15HS1N1S02	1.1 ±0.3nH	100	300	0.09 max.	8	100	6000
LQG15HS1N2S02	1.2 ±0.3nH	100	300	0.09 max.	8	100	6000
LQG15HS1N3S02	1.3 ±0.3nH	100	300	0.09 max.	8	100	6000
LQG15HS1N5S02	1.5 ±0.3nH	100	300	0.1 max.	8	100	6000
LQG15HS1N6S02	1.6 ±0.3nH	100	300	0.1 max.	8	100	6000
LQG15HS1N8S02	1.8 ±0.3nH	100	300	0.1 max.	8	100	6000
LQG15HS2N0S02	2.0 ±0.3nH	100	300	0.1 max.	8	100	6000
LQG15HS2N2S02	2.2 ±0.3nH	100	300	0.12 max.	8	100	6000
LQG15HS2N4S02	2.4 ±0.3nH	100	300	0.15 max.	8	100	6000
LQG15HS2N7S02	2.7 ±0.3nH	100	300	0.15 max.	8	100	6000
LQG15HS3N0S02	3.0 ±0.3nH	100	300	0.17 max.	8	100	6000
LQG15HS3N3S02	3.3 ±0.3nH	100	300	0.17 max.	8	100	6000
LQG15HS3N6S02	3.6 ±0.3nH	100	300	0.18 max.	8	100	6000
LQG15HS3N9S02	3.9 ±0.3nH	100	300	0.18 max.	8	100	6000
LQG15HS4N3S02	4.3 ±0.3nH	100	300	0.18 max.	8	100	6000
LQG15HS4N7S02	4.7 ±0.3nH	100	300	0.18 max.	8	100	6000

Continued on the following page.

Continued from the preceding page.

Part Number	Inductance (nH)	Test Frequency (MHz)	Rated Current (mA)	DC Resistance (ohm)	Q (min.)	Test Frequency (MHz)	Self Resonance Frequency (min.) (MHz)
LQG15HS5N1S02	5.1 ±0.3nH	100	300	0.2 max.	8	100	5300
LQG15HS5N6S02	5.6 ±0.3nH	100	300	0.2 max.	8	100	4500
LQG15HS6N2S02	6.2 ±0.3nH	100	300	0.22 max.	8	100	4500
LQG15HS6N8J02	6.8 ±5%	100	300	0.24 max.	8	100	4500
LQG15HS7N5J02	7.5 ±5%	100	300	0.24 max.	8	100	4200
LQG15HS8N2J02	8.2 ±5%	100	300	0.24 max.	8	100	3700
LQG15HS9N1J02	9.1 ±5%	100	300	0.26 max.	8	100	3400
LQG15HS10NJ02	10 ±5%	100	300	0.26 max.	8	100	3400
LQG15HS12NJ02	12 ±5%	100	300	0.28 max.	8	100	3000
LQG15HS15NJ02	15 ±5%	100	300	0.32 max.	8	100	2500
LQG15HS18NJ02	18 ±5%	100	300	0.36 max.	8	100	2200
LQG15HS22NJ02	22 ±5%	100	300	0.42 max.	8	100	1900
LQG15HS27NJ02	27 ±5%	100	300	0.46 max.	8	100	1700
LQG15HS33NJ02	33 ±5%	100	200	0.58 max.	8	100	1600
LQG15HS39NJ02	39 ±5%	100	200	0.65 max.	8	100	1200
LQG15HS47NJ02	47 ±5%	100	200	0.72 max.	8	100	1000
LQG15HS56NJ02	56 ±5%	100	200	0.82 max.	8	100	800
LQG15HS68NJ02	68 ±5%	100	180	0.92 max.	8	100	800
LQG15HS82NJ02	82 ±5%	100	150	1.2 max.	8	100	700
LQG15HSR10J02	100 ±5%	100	150	1.25 max.	8	100	600
LQG15HSR12J02	120 ±5%	100	150	1.3 max.	8	100	600
LQG15HSR15J02	150 ±5%	100	140	2.99 max.	8	100	550
LQG15HSR18J02	180 ±5%	100	130	3.38 max.	8	100	500
LQG15HSR22J02	220 ±5%	100	120	3.77 max.	8	100	450
LQG15HSR27J02	270 ±5%	100	110	4.94 max.	8	100	400

Operating Temperature Range: -55 to +125°C

Only for reflow soldering.

● LQG18H Series (0603)

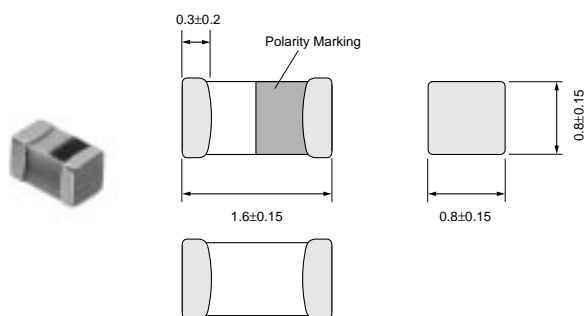

(in mm)

Part Number	Inductance (nH)	Test Frequency (MHz)	Rated Current (mA)	DC Resistance (ohm)	Q (min.)	Test Frequency (MHz)	Self Resonance Frequency (min.) (MHz)
LQG18HN1N2S00	1.2 ±0.3nH	100	500	0.10 max.	12	100	6000
LQG18HN1N5S00	1.5 ±0.3nH	100	500	0.10 max.	12	100	6000
LQG18HN1N8S00	1.8 ±0.3nH	100	500	0.10 max.	12	100	6000
LQG18HN2N2S00	2.2 ±0.3nH	100	500	0.10 max.	12	100	6000
LQG18HN2N7S00	2.7 ±0.3nH	100	500	0.15 max.	12	100	6000
LQG18HN3N3S00	3.3 ±0.3nH	100	500	0.15 max.	12	100	6000
LQG18HN3N9S00	3.9 ±0.3nH	100	450	0.15 max.	12	100	6000
LQG18HN4N7S00	4.7 ±0.3nH	100	450	0.20 max.	12	100	6000
LQG18HN5N6S00	5.6 ±0.3nH	100	430	0.20 max.	12	100	5000
LQG18HN6N8J00	6.8 ±5%	100	430	0.25 max.	12	100	5000

Continued on the following page. ↗

△Note • This PDF catalog is downloaded from the website of Murata Manufacturing co., Ltd. Therefore, it's specifications are subject to change or our products in it may be discontinued without advance notice. Please check with our sales representatives or product engineers before ordering.
• This PDF catalog has only typical specifications because there is no space for detailed specifications. Therefore, please approve our product specifications or transact the approval sheet for product specifications before ordering.

Part Number	Inductance (nH)	Test Frequency (MHz)	Rated Current (mA)	DC Resistance (ohm)	Q (min.)	Test Frequency (MHz)	Self Resonance Frequency (min.) (MHz)
LQG18HN8N2J00	8.2 ±5%	100	400	0.25 max.	12	100	4000
LQG18HN10NJ00	10 ±5%	100	400	0.30 max.	12	100	3500
LQG18HN12NJ00	12 ±5%	100	400	0.35 max.	12	100	3000
LQG18HN15NJ00	15 ±5%	100	350	0.40 max.	12	100	2800
LQG18HN18NJ00	18 ±5%	100	350	0.45 max.	12	100	2600
LQG18HN22NJ00	22 ±5%	100	300	0.50 max.	12	100	2300
LQG18HN27NJ00	27 ±5%	100	300	0.55 max.	12	100	2000
LQG18HN33NJ00	33 ±5%	100	300	0.60 max.	12	100	1700
LQG18HN39NJ00	39 ±5%	100	300	0.65 max.	12	100	1500
LQG18HN47NJ00	47 ±5%	100	300	0.70 max.	12	100	1200
LQG18HN56NJ00	56 ±5%	100	300	0.75 max.	12	100	1100
LQG18HN68NJ00	68 ±5%	100	300	0.80 max.	12	100	1000
LQG18HN82NJ00	82 ±5%	100	300	0.85 max.	12	100	900
LQG18HNR10J00	100 ±5%	100	300	0.90 max.	12	100	800

Operating Temperature Range: -40 to +85°C
Only for reflow soldering.

Chip Inductor (Chip Coil)

for High Frequency Film Type

● LQP02T Series (01005)

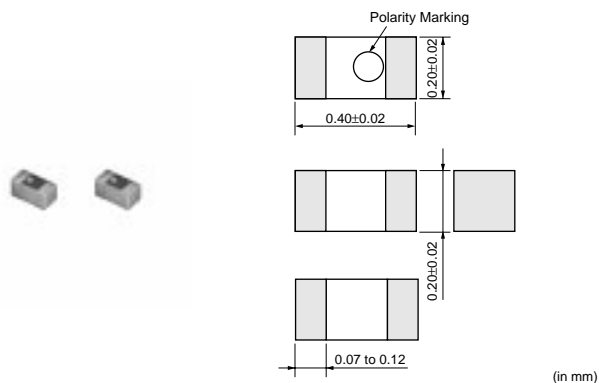

Part Number	Inductance (nH)	Test Frequency (MHz)	Rated Current (mA)	DC Resistance (ohm)	Q (min.)	Test Frequency (MHz)	Self Resonance Frequency (min.) (MHz)
LQP02TN0N4S02	0.4 ±0.3nH	500	320	0.60 max.	8	500	6000
LQP02TN0N5S02	0.5 ±0.3nH	500	320	0.60 max.	8	500	6000
LQP02TN0N6S02	0.6 ±0.3nH	500	320	0.60 max.	8	500	6000
LQP02TN0N7S02	0.7 ±0.3nH	500	320	0.60 max.	8	500	6000
LQP02TN0N8S02	0.8 ±0.3nH	500	320	0.60 max.	8	500	6000
LQP02TN0N9S02	0.9 ±0.3nH	500	320	0.60 max.	8	500	6000
LQP02TN1N0S02	1.0 ±0.3nH	500	220	0.90 max.	8	500	6000
LQP02TN1N1S02	1.1 ±0.3nH	500	220	0.90 max.	8	500	6000
LQP02TN1N2S02	1.2 ±0.3nH	500	220	0.90 max.	8	500	6000
LQP02TN1N3S02	1.3 ±0.3nH	500	220	0.90 max.	8	500	6000
LQP02TN1N5S02	1.5 ±0.3nH	500	220	0.90 max.	8	500	6000
LQP02TN1N6S02	1.6 ±0.3nH	500	220	0.90 max.	8	500	6000
LQP02TN1N8S02	1.8 ±0.3nH	500	200	1.35 max.	8	500	6000
LQP02TN2N0S02	2.0 ±0.3nH	500	200	1.35 max.	8	500	6000
LQP02TN2N2S02	2.2 ±0.3nH	500	200	1.35 max.	8	500	6000
LQP02TN2N4S02	2.4 ±0.3nH	500	200	1.35 max.	8	500	6000
LQP02TN2N7S02	2.7 ±0.3nH	500	200	1.35 max.	8	500	6000

Continued on the following page.

Continued from the preceding page.

Part Number	Inductance (nH)	Test Frequency (MHz)	Rated Current (mA)	DC Resistance (ohm)	Q (min.)	Test Frequency (MHz)	Self Resonance Frequency (min.) (MHz)
LQP02TN3N0S02	3.0 ±0.3nH	500	200	1.35 max.	8	500	6000
LQP02TN3N3S02	3.3 ±0.3nH	500	180	1.65 max.	8	500	6000
LQP02TN3N6S02	3.6 ±0.3nH	500	180	1.65 max.	8	500	6000
LQP02TN3N9S02	3.9 ±0.3nH	500	180	1.65 max.	8	500	6000
LQP02TN4N3S02	4.3 ±0.3nH	500	180	1.65 max.	8	500	6000
LQP02TN4N7S02	4.7 ±0.3nH	500	160	2.10 max.	8	500	6000
LQP02TN5N1S02	5.1 ±0.3nH	500	160	2.10 max.	8	500	6000
LQP02TN5N6S02	5.6 ±0.3nH	500	140	2.40 max.	8	500	6000
LQP02TN6N2J02	6.2 ±5%	500	140	2.40 max.	8	500	5500
LQP02TN6N8J02	6.8 ±5%	500	140	2.85 max.	8	500	5500
LQP02TN7N5J02	7.5 ±5%	500	140	2.85 max.	8	500	4500
LQP02TN8N2J02	8.2 ±5%	500	140	3.15 max.	8	500	5000
LQP02TN9N1J02	9.1 ±5%	500	140	3.15 max.	8	500	4000
LQP02TN10N0J02	10 ±5%	500	140	3.60 max.	8	500	4000
LQP02TN12N0J02	12 ±5%	500	140	3.90 max.	7	500	3500
LQP02TN15N0J02	15 ±5%	500	140	4.35 max.	7	500	3000
LQP02TN18N0J02	18 ±5%	500	140	4.80 max.	7	500	2500

Operating Temperature Range: -40 to +85°C
 Only for reflow soldering.

● LQP03T Series (0201)

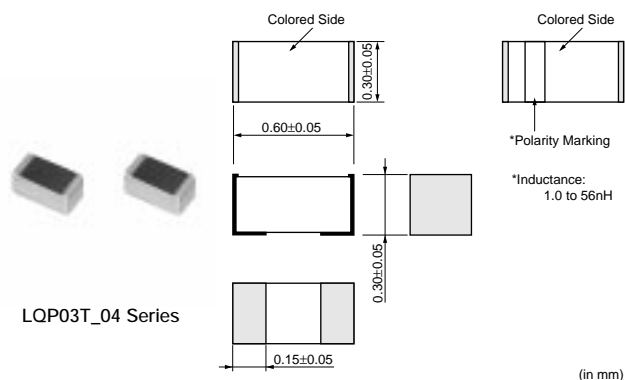
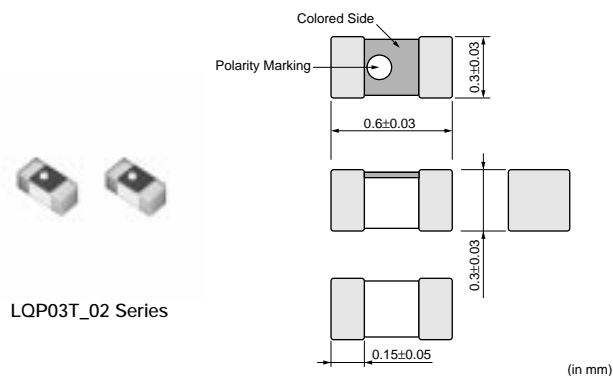
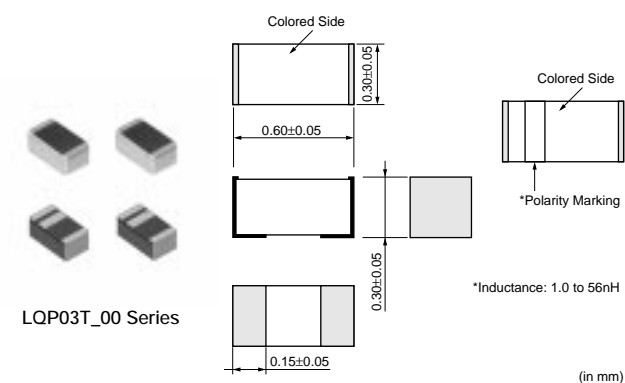

Part Number	Inductance (nH)	Test Frequency (MHz)	Rated Current (mA)	DC Resistance (ohm)	Q (min.)	Test Frequency (MHz)	Self Resonance Frequency (min.) (MHz)
LQP03TN0N6B00	0.6 ±0.1nH	500	840	0.08 max.	13	500	6000
LQP03TN0N6C00	0.6 ±0.2nH	500	840	0.08 max.	13	500	6000
LQP03TN0N7B00	0.7 ±0.1nH	500	820	0.09 max.	13	500	6000
LQP03TN0N8B00	0.8 ±0.1nH	500	820	0.09 max.	13	500	6000
LQP03TN0N8C00	0.8 ±0.2nH	500	820	0.09 max.	13	500	6000

Continued on the following page. ↗

△Note • This PDF catalog is downloaded from the website of Murata Manufacturing co., ltd. Therefore, it's specifications are subject to change or our products in it may be discontinued without advance notice. Please check with our sales representatives or product engineers before ordering.
 • This PDF catalog has only typical specifications because there is no space for detailed specifications. Therefore, please approve our product specifications or transact the approval sheet for product specifications before ordering.

Continued from the preceding page.

Part Number	Inductance (nH)	Test Frequency (MHz)	Rated Current (mA)	DC Resistance (ohm)	Q (min.)	Test Frequency (MHz)	Self Resonance Frequency (min.) (MHz)
LQP03TN0N9B00	0.9 ±0.1nH	500	800	0.10 max.	13	500	6000
LQP03TN1N0B00	1.0 ±0.1nH	500	800	0.10 max.	13	500	6000
LQP03TN1N0C00	1.0 ±0.2nH	500	800	0.10 max.	13	500	6000
LQP03TN1N1B00	1.1 ±0.1nH	500	560	0.13 max.	13	500	6000
LQP03TN1N2B00	1.2 ±0.1nH	500	560	0.13 max.	13	500	6000
LQP03TN1N2C00	1.2 ±0.2nH	500	560	0.13 max.	13	500	6000
LQP03TN1N3B00	1.3 ±0.1nH	500	560	0.16 max.	13	500	6000
LQP03TN1N4B00	1.4 ±0.1nH	500	560	0.16 max.	13	500	6000
LQP03TN1N5B00	1.5 ±0.1nH	500	560	0.16 max.	13	500	6000
LQP03TN1N5C00	1.5 ±0.2nH	500	560	0.16 max.	13	500	6000
LQP03TN1N6B00	1.6 ±0.1nH	500	560	0.16 max.	13	500	6000
LQP03TN1N7B00	1.7 ±0.1nH	500	560	0.16 max.	13	500	6000
LQP03TN1N8B00	1.8 ±0.1nH	500	560	0.16 max.	13	500	6000
LQP03TN1N8C00	1.8 ±0.2nH	500	560	0.16 max.	13	500	6000
LQP03TN1N9B00	1.9 ±0.1nH	500	440	0.18 max.	13	500	6000
LQP03TN2N0B00	2.0 ±0.1nH	500	440	0.18 max.	13	500	6000
LQP03TN2N1B00	2.1 ±0.1nH	500	440	0.18 max.	13	500	6000
LQP03TN2N2B00	2.2 ±0.1nH	500	440	0.18 max.	13	500	6000
LQP03TN2N2C00	2.2 ±0.2nH	500	440	0.18 max.	13	500	6000
LQP03TN2N3B00	2.3 ±0.1nH	500	440	0.21 max.	13	500	6000
LQP03TN2N4B00	2.4 ±0.1nH	500	440	0.21 max.	13	500	6000
LQP03TN2N5B00	2.5 ±0.1nH	500	440	0.21 max.	13	500	6000
LQP03TN2N6B00	2.6 ±0.1nH	500	440	0.21 max.	13	500	6000
LQP03TN2N7B00	2.7 ±0.1nH	500	440	0.21 max.	13	500	6000
LQP03TN2N7C00	2.7 ±0.2nH	500	440	0.21 max.	13	500	6000
LQP03TN2N8B00	2.8 ±0.1nH	500	440	0.21 max.	13	500	6000
LQP03TN2N9B00	2.9 ±0.1nH	500	440	0.21 max.	13	500	6000
LQP03TN3N0B00	3.0 ±0.1nH	500	380	0.30 max.	13	500	6000
LQP03TN3N1B00	3.1 ±0.1nH	500	380	0.30 max.	13	500	6000
LQP03TN3N2B00	3.2 ±0.1nH	500	380	0.30 max.	13	500	6000
LQP03TN3N3B00	3.3 ±0.1nH	500	380	0.30 max.	13	500	6000
LQP03TN3N3C00	3.3 ±0.2nH	500	380	0.30 max.	13	500	6000
LQP03TN3N4B00	3.4 ±0.1nH	500	380	0.30 max.	13	500	6000
LQP03TN3N5B00	3.5 ±0.1nH	500	380	0.30 max.	13	500	6000
LQP03TN3N6B00	3.6 ±0.1nH	500	340	0.45 max.	13	500	6000
LQP03TN3N7B00	3.7 ±0.1nH	500	340	0.45 max.	13	500	6000
LQP03TN3N8B00	3.8 ±0.1nH	500	340	0.45 max.	13	500	6000
LQP03TN3N9B00	3.9 ±0.1nH	500	340	0.45 max.	13	500	6000
LQP03TN3N9C00	3.9 ±0.2nH	500	340	0.45 max.	13	500	6000
LQP03TN4N3H00	4.3 ±3%	500	320	0.55 max.	13	500	6000
LQP03TN4N7H00	4.7 ±3%	500	320	0.55 max.	13	500	6000
LQP03TN4N7J00	4.7 ±5%	500	320	0.55 max.	13	500	6000
LQP03TN5N1H00	5.1 ±3%	500	280	0.68 max.	13	500	6000
LQP03TN5N6H00	5.6 ±3%	500	280	0.68 max.	13	500	6000
LQP03TN5N6J00	5.6 ±5%	500	280	0.68 max.	13	500	6000
LQP03TN6N2H00	6.2 ±3%	500	260	0.75 max.	13	500	6000
LQP03TN6N8H00	6.8 ±3%	500	260	0.75 max.	13	500	6000
LQP03TN6N8J00	6.8 ±5%	500	260	0.75 max.	13	500	6000
LQP03TN7N5H00	7.5 ±3%	500	220	0.86 max.	13	500	5500
LQP03TN8N2H00	8.2 ±3%	500	220	0.86 max.	13	500	5500
LQP03TN8N2J00	8.2 ±5%	500	220	0.86 max.	13	500	5500
LQP03TN9N1H00	9.1 ±3%	500	200	1.10 max.	13	500	4500
LQP03TN10NH00	10 ±3%	500	200	1.10 max.	13	500	4500
LQP03TN10NJ00	10 ±5%	500	200	1.10 max.	13	500	4500
LQP03TN12NH00	12 ±3%	500	180	1.25 max.	11	500	3700

Continued on the following page.

 Continued from the preceding page.

Part Number	Inductance (nH)	Test Frequency (MHz)	Rated Current (mA)	DC Resistance (ohm)	Q (min.)	Test Frequency (MHz)	Self Resonance Frequency (min.) (MHz)
LQP03TN12NJ00	12 ±5%	500	180	1.25 max.	11	500	3700
LQP03TN15NH00	15 ±3%	500	180	1.40 max.	11	500	3300
LQP03TN15NJ00	15 ±5%	500	180	1.40 max.	11	500	3300
LQP03TN18NH00	18 ±3%	500	160	1.60 max.	11	500	3100
LQP03TN18NJ00	18 ±5%	500	160	1.60 max.	11	500	3100
LQP03TN22NH00	22 ±3%	500	140	2.55 max.	11	500	2800
LQP03TN22NJ00	22 ±5%	500	140	2.55 max.	11	500	2800
LQP03TN27NH00	27 ±3%	500	140	2.90 max.	11	500	2500
LQP03TN27NJ00	27 ±5%	500	140	2.90 max.	11	500	2500
LQP03TN33NJ00	33 ±5%	300	120	2.95 max.	8	300	2000
LQP03TN39NJ00	39 ±5%	300	120	3.35 max.	8	300	1800
LQP03TN47NJ00	47 ±5%	300	100	3.60 max.	8	300	1600
LQP03TN56NJ00	56 ±5%	300	100	4.30 max.	8	300	1400
LQP03TN0N6C02	0.6 ±0.2nH	500	850	0.07 max.	14	500	6000
LQP03TN0N7C02	0.7 ±0.2nH	500	800	0.08 max.	14	500	6000
LQP03TN0N8C02	0.8 ±0.2nH	500	800	0.08 max.	14	500	6000
LQP03TN0N9C02	0.9 ±0.2nH	500	750	0.10 max.	14	500	6000
LQP03TN1N0C02	1.0 ±0.2nH	500	750	0.10 max.	14	500	6000
LQP03TN1N1C02	1.1 ±0.2nH	500	750	0.10 max.	14	500	6000
LQP03TN1N2C02	1.2 ±0.2nH	500	750	0.10 max.	14	500	6000
LQP03TN1N3C02	1.3 ±0.2nH	500	600	0.15 max.	14	500	6000
LQP03TN1N5C02	1.5 ±0.2nH	500	600	0.15 max.	14	500	6000
LQP03TN1N6C02	1.6 ±0.2nH	500	600	0.15 max.	14	500	6000
LQP03TN1N8C02	1.8 ±0.2nH	500	600	0.15 max.	14	500	6000
LQP03TN2N0C02	2.0 ±0.2nH	500	600	0.15 max.	14	500	6000
LQP03TN2N2C02	2.2 ±0.2nH	500	600	0.15 max.	14	500	6000
LQP03TN2N4C02	2.4 ±0.2nH	500	500	0.20 max.	14	500	6000
LQP03TN2N7C02	2.7 ±0.2nH	500	500	0.20 max.	14	500	6000
LQP03TN3N0C02	3.0 ±0.2nH	500	450	0.25 max.	14	500	6000
LQP03TN3N3C02	3.3 ±0.2nH	500	450	0.25 max.	14	500	6000
LQP03TN3N6C02	3.6 ±0.2nH	500	400	0.30 max.	14	500	6000
LQP03TN3N9C02	3.9 ±0.2nH	500	400	0.30 max.	14	500	5700
LQP03TN5N1J02	5.1 ±5%	500	350	0.40 max.	14	500	4200
LQP03TN5N6J02	5.6 ±5%	500	350	0.40 max.	14	500	4000
LQP03TN6N2J02	6.2 ±5%	500	300	0.60 max.	14	500	4000
LQP03TN6N8J02	6.8 ±5%	500	300	0.60 max.	14	500	3900
LQP03TN7N5J02	7.5 ±5%	500	300	0.60 max.	14	500	3700
LQP03TN8N2J02	8.2 ±5%	500	250	0.70 max.	14	500	3600
LQP03TN9N1J02	9.1 ±5%	500	250	0.70 max.	14	500	3300
LQP03TN10NJ02	10 ±5%	500	250	0.70 max.	14	500	3200
LQP03TN12NJ02	12 ±5%	500	250	0.70 max.	12	500	2900
LQP03TN15NJ02	15 ±5%	500	250	0.70 max.	12	500	2600
LQP03TN22NJ02	22 ±5%	500	150	1.90 max.	12	500	2200
LQP03TN27NJ02	27 ±5%	500	140	2.30 max.	12	500	2000
LQP03TN33NJ02	33 ±5%	300	120	2.95 max.	9	300	1700
LQP03TN39NJ02	39 ±5%	300	120	3.00 max.	9	300	1500
LQP03TN47NJ02	47 ±5%	300	100	3.60 max.	9	300	1300
LQP03TN56NJ02	56 ±5%	300	100	3.90 max.	9	300	1200
LQP03TN68NJ02	68 ±5%	300	50	8.00 max.	8	300	1100
LQP03TN82NJ02	82 ±5%	300	50	10.0 max.	8	300	1000
LQP03TNR10J02	100 ±5%	300	40	10.0 max.	8	300	900
LQP03TNR12J02	120 ±5%	300	40	12.0 max.	8	300	800
LQP03TN0N6B04	0.6 ±0.1nH	500	420	0.08 max.	13	500	6000
LQP03TN0N6C04	0.6 ±0.2nH	500	420	0.08 max.	13	500	6000
LQP03TN0N7B04	0.7 ±0.1nH	500	410	0.09 max.	13	500	6000

Continued on the following page. 

Note • This PDF catalog is downloaded from the website of Murata Manufacturing co., Ltd. Therefore, it's specifications are subject to change or our products in it may be discontinued without advance notice. Please check with our sales representatives or product engineers before ordering.
 • This PDF catalog has only typical specifications because there is no space for detailed specifications. Therefore, please approve our product specifications or transact the approval sheet for product specifications before ordering.

Continued from the preceding page.

Part Number	Inductance (nH)	Test Frequency (MHz)	Rated Current (mA)	DC Resistance (ohm)	Q (min.)	Test Frequency (MHz)	Self Resonance Frequency (min.) (MHz)
LQP03TN0N8B04	0.8 ±0.1nH	500	410	0.09 max.	13	500	6000
LQP03TN0N8C04	0.8 ±0.2nH	500	410	0.09 max.	13	500	6000
LQP03TN0N9B04	0.9 ±0.1nH	500	400	0.10 max.	13	500	6000
LQP03TN1N0B04	1.0 ±0.1nH	500	400	0.10 max.	13	500	6000
LQP03TN1N0C04	1.0 ±0.2nH	500	400	0.10 max.	13	500	6000
LQP03TN1N1B04	1.1 ±0.1nH	500	280	0.13 max.	13	500	6000
LQP03TN1N2B04	1.2 ±0.1nH	500	280	0.13 max.	13	500	6000
LQP03TN1N2C04	1.2 ±0.2nH	500	280	0.13 max.	13	500	6000
LQP03TN1N3B04	1.3 ±0.1nH	500	280	0.16 max.	13	500	6000
LQP03TN1N4B04	1.4 ±0.1nH	500	280	0.16 max.	13	500	6000
LQP03TN1N5B04	1.5 ±0.1nH	500	280	0.16 max.	13	500	6000
LQP03TN1N5C04	1.5 ±0.2nH	500	280	0.16 max.	13	500	6000
LQP03TN1N6B04	1.6 ±0.1nH	500	280	0.16 max.	13	500	6000
LQP03TN1N7B04	1.7 ±0.1nH	500	280	0.16 max.	13	500	6000
LQP03TN1N8B04	1.8 ±0.1nH	500	280	0.16 max.	13	500	6000
LQP03TN1N8C04	1.8 ±0.2nH	500	280	0.16 max.	13	500	6000
LQP03TN1N9B04	1.9 ±0.1nH	500	220	0.18 max.	13	500	6000
LQP03TN2N0B04	2.0 ±0.1nH	500	220	0.18 max.	13	500	6000
LQP03TN2N1B04	2.1 ±0.1nH	500	220	0.18 max.	13	500	6000
LQP03TN2N2B04	2.2 ±0.1nH	500	220	0.18 max.	13	500	6000
LQP03TN2N2C04	2.2 ±0.2nH	500	220	0.18 max.	13	500	6000
LQP03TN2N3B04	2.3 ±0.1nH	500	220	0.20 max.	13	500	6000
LQP03TN2N4B04	2.4 ±0.1nH	500	220	0.20 max.	13	500	6000
LQP03TN2N5B04	2.5 ±0.1nH	500	220	0.20 max.	13	500	6000
LQP03TN2N6B04	2.6 ±0.1nH	500	220	0.20 max.	13	500	6000
LQP03TN2N7B04	2.7 ±0.1nH	500	220	0.20 max.	13	500	6000
LQP03TN2N7C04	2.7 ±0.2nH	500	220	0.20 max.	13	500	6000
LQP03TN2N8B04	2.8 ±0.1nH	500	220	0.20 max.	13	500	6000
LQP03TN2N9B04	2.9 ±0.1nH	500	220	0.20 max.	13	500	6000
LQP03TN3N0B04	3.0 ±0.1nH	500	190	0.20 max.	13	500	6000
LQP03TN3N1B04	3.1 ±0.1nH	500	190	0.20 max.	13	500	6000
LQP03TN3N2B04	3.2 ±0.1nH	500	190	0.20 max.	13	500	6000
LQP03TN3N3B04	3.3 ±0.1nH	500	190	0.20 max.	13	500	6000
LQP03TN3N3C04	3.3 ±0.2nH	500	190	0.20 max.	13	500	6000
LQP03TN3N4B04	3.4 ±0.1nH	500	190	0.30 max.	13	500	6000
LQP03TN3N5B04	3.5 ±0.1nH	500	190	0.30 max.	13	500	6000
LQP03TN3N6B04	3.6 ±0.1nH	500	170	0.30 max.	13	500	6000
LQP03TN3N7B04	3.7 ±0.1nH	500	170	0.30 max.	13	500	6000
LQP03TN3N8B04	3.8 ±0.1nH	500	170	0.30 max.	13	500	6000
LQP03TN3N9B04	3.9 ±0.1nH	500	170	0.30 max.	13	500	6000
LQP03TN3N9C04	3.9 ±0.2nH	500	170	0.30 max.	13	500	6000
LQP03TN4N3H04	4.3 ±3%	500	160	0.40 max.	13	500	6000
LQP03TN4N7H04	4.7 ±3%	500	160	0.40 max.	13	500	6000
LQP03TN4N7J04	4.7 ±5%	500	160	0.40 max.	13	500	6000
LQP03TN5N1H04	5.1 ±3%	500	140	0.55 max.	13	500	6000
LQP03TN5N6H04	5.6 ±3%	500	140	0.55 max.	13	500	6000
LQP03TN5N6J04	5.6 ±5%	500	140	0.55 max.	13	500	6000
LQP03TN6N2H04	6.2 ±3%	500	130	0.60 max.	13	500	6000
LQP03TN6N2J04	6.2 ±5%	500	130	0.60 max.	13	500	6000
LQP03TN6N8H04	6.8 ±3%	500	130	0.60 max.	13	500	6000
LQP03TN6N8J04	6.8 ±5%	500	130	0.60 max.	13	500	6000
LQP03TN7N5H04	7.5 ±3%	500	110	0.65 max.	13	500	5500
LQP03TN7N5J04	7.5 ±5%	500	110	0.65 max.	13	500	5500
LQP03TN8N2H04	8.2 ±3%	500	110	0.86 max.	13	500	5500
LQP03TN8N2J04	8.2 ±5%	500	110	0.86 max.	13	500	5500

Continued on the following page.

Continued from the preceding page.

Part Number	Inductance (nH)	Test Frequency (MHz)	Rated Current (mA)	DC Resistance (ohm)	Q (min.)	Test Frequency (MHz)	Self Resonance Frequency (min.) (MHz)
LQP03TN9N1H04	9.1 ±3%	500	100	1.10 max.	13	500	4500
LQP03TN9N1J04	9.1 ±5%	500	100	1.10 max.	13	500	4500
LQP03TN10NH04	10 ±3%	500	100	1.10 max.	13	500	4500
LQP03TN10NJ04	10 ±5%	500	100	1.10 max.	13	500	4500
LQP03TN12NH04	12 ±3%	500	90	1.15 max.	11	500	3700
LQP03TN12NJ04	12 ±5%	500	90	1.15 max.	11	500	3700
LQP03TN15NH04	15 ±3%	500	90	1.40 max.	11	500	3300
LQP03TN15NJ04	15 ±5%	500	90	1.40 max.	11	500	3300
LQP03TN18NH04	18 ±3%	500	80	1.60 max.	11	500	3100
LQP03TN18NJ04	18 ±5%	500	80	1.60 max.	11	500	3100
LQP03TN22NH04	22 ±3%	500	70	2.55 max.	11	500	2800
LQP03TN22NJ04	22 ±5%	500	70	2.55 max.	11	500	2800
LQP03TN27NH04	27 ±3%	500	70	2.90 max.	11	500	2500
LQP03TN27NJ04	27 ±5%	500	70	2.90 max.	11	500	2500
LQP03TN33NJ04	33 ±5%	300	60	2.95 max.	8	300	2000
LQP03TN39NJ04	39 ±5%	300	60	3.35 max.	8	300	1800
LQP03TN47NJ04	47 ±5%	300	50	3.60 max.	8	300	1600
LQP03TN56NJ04	56 ±5%	300	50	4.30 max.	8	300	1400

Operating Temperature Range: -40 to +85°C

Only for reflow soldering.

● LQP15T Series (0402)

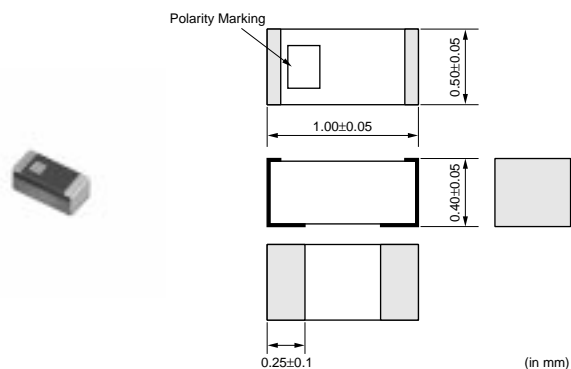

Part Number	Inductance (nH)	Test Frequency (MHz)	Rated Current (mA)	DC Resistance (ohm)	Q (min.)	Test Frequency (MHz)	Self Resonance Frequency (min.) (MHz)
LQP15TN1N0B02	1.0 ±0.1nH	500	300	0.1 max.	17	500	6000
LQP15TN1N0C02	1.0 ±0.2nH	500	300	0.1 max.	17	500	6000
LQP15TN1N1B02	1.1 ±0.1nH	500	300	0.1 max.	17	500	6000
LQP15TN1N1C02	1.1 ±0.2nH	500	300	0.1 max.	17	500	6000
LQP15TN1N2B02	1.2 ±0.1nH	500	300	0.1 max.	17	500	6000
LQP15TN1N2C02	1.2 ±0.2nH	500	300	0.1 max.	17	500	6000
LQP15TN1N3B02	1.3 ±0.1nH	500	300	0.15 max.	17	500	6000
LQP15TN1N3C02	1.3 ±0.2nH	500	300	0.15 max.	17	500	6000
LQP15TN1N5B02	1.5 ±0.1nH	500	300	0.15 max.	17	500	6000
LQP15TN1N5C02	1.5 ±0.2nH	500	300	0.15 max.	17	500	6000
LQP15TN1N6B02	1.6 ±0.1nH	500	250	0.15 max.	17	500	6000
LQP15TN1N6C02	1.6 ±0.2nH	500	250	0.15 max.	17	500	6000
LQP15TN1N8B02	1.8 ±0.1nH	500	250	0.15 max.	17	500	6000
LQP15TN1N8C02	1.8 ±0.2nH	500	250	0.15 max.	17	500	6000
LQP15TN2N0C02	2.0 ±0.2nH	500	220	0.2 max.	17	500	6000
LQP15TN2N2C02	2.2 ±0.2nH	500	220	0.2 max.	17	500	6000
LQP15TN2N4C02	2.4 ±0.2nH	500	220	0.2 max.	17	500	6000

Continued on the following page. ↗

△Note • This PDF catalog is downloaded from the website of Murata Manufacturing co., Ltd. Therefore, it's specifications are subject to change or our products in it may be discontinued without advance notice. Please check with our sales representatives or product engineers before ordering.
• This PDF catalog has only typical specifications because there is no space for detailed specifications. Therefore, please approve our product specifications or transact the approval sheet for product specifications before ordering.

Continued from the preceding page.

Part Number	Inductance (nH)	Test Frequency (MHz)	Rated Current (mA)	DC Resistance (ohm)	Q (min.)	Test Frequency (MHz)	Self Resonance Frequency (min.) (MHz)
LQP15TN2N7C02	2.7 ±0.2nH	500	220	0.2 max.	17	500	6000
LQP15TN3N0C02	3.0 ±0.2nH	500	190	0.3 max.	17	500	5500
LQP15TN3N3C02	3.3 ±0.2nH	500	190	0.3 max.	17	500	5500
LQP15TN3N6C02	3.6 ±0.2nH	500	170	0.3 max.	17	500	5500
LQP15TN3N9C02	3.9 ±0.2nH	500	170	0.4 max.	17	500	5500
LQP15TN4N7C02	4.7 ±0.2nH	500	160	0.5 max.	17	500	5000
LQP15TN5N6C02	5.6 ±0.2nH	500	140	0.6 max.	17	500	4500
LQP15TN6N8H02	6.8 ±3%	500	130	0.7 max.	17	500	3500
LQP15TN8N2H02	8.2 ±3%	500	110	0.8 max.	17	500	3000
LQP15TN10NH02	10 ±3%	500	100	1.0 max.	17	500	2500
LQP15TN12NH02	12 ±3%	500	90	1.0 max.	17	500	2500
LQP15TN15NH02	15 ±3%	500	90	1.3 max.	17	500	2000
LQP15TN18NH02	18 ±3%	500	80	1.5 max.	17	500	1500

 Operating Temperature Range: -40 to +85°C
 Only for reflow soldering.

● LQP15M Series (0402)

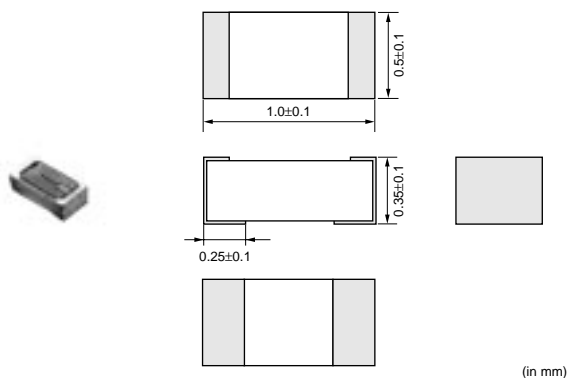

Part Number	Inductance (nH)	Test Frequency (MHz)	Rated Current (mA)	DC Resistance (ohm)	Q (min.)	Test Frequency (MHz)	Self Resonance Frequency (min.) (MHz)
LQP15MN1N0B02	1.0 ±0.1nH	500	400	0.1 max.	13	500	6000
LQP15MN1N0W02	1.0 ±0.05nH	500	400	0.1 max.	13	500	6000
LQP15MN1N1B02	1.1 ±0.1nH	500	390	0.1 max.	13	500	6000
LQP15MN1N1W02	1.1 ±0.05nH	500	390	0.1 max.	13	500	6000
LQP15MN1N2B02	1.2 ±0.1nH	500	390	0.1 max.	13	500	6000
LQP15MN1N2W02	1.2 ±0.05nH	500	390	0.1 max.	13	500	6000
LQP15MN1N3B02	1.3 ±0.1nH	500	280	0.2 max.	13	500	6000
LQP15MN1N3W02	1.3 ±0.05nH	500	280	0.2 max.	13	500	6000
LQP15MN1N4W02	1.4 ±0.05nH	500	280	0.2 max.	13	500	6000
LQP15MN1N5B02	1.5 ±0.1nH	500	280	0.2 max.	13	500	6000
LQP15MN1N5W02	1.5 ±0.05nH	500	280	0.2 max.	13	500	6000
LQP15MN1N6B02	1.6 ±0.1nH	500	220	0.3 max.	13	500	6000
LQP15MN1N6W02	1.6 ±0.05nH	500	220	0.3 max.	13	500	6000
LQP15MN1N7W02	1.7 ±0.05nH	500	280	0.2 max.	13	500	6000
LQP15MN1N8B02	1.8 ±0.1nH	500	280	0.2 max.	13	500	6000
LQP15MN1N8W02	1.8 ±0.05nH	500	280	0.2 max.	13	500	6000
LQP15MN1N9W02	1.9 ±0.05nH	500	220	0.3 max.	13	500	6000
LQP15MN2N0B02	2.0 ±0.1nH	500	220	0.3 max.	13	500	6000
LQP15MN2N0W02	2.0 ±0.05nH	500	220	0.3 max.	13	500	6000
LQP15MN2N1W02	2.1 ±0.05nH	500	220	0.3 max.	13	500	6000
LQP15MN2N2B02	2.2 ±0.1nH	500	220	0.3 max.	13	500	6000
LQP15MN2N2W02	2.2 ±0.05nH	500	220	0.3 max.	13	500	6000

Continued on the following page.

 Continued from the preceding page.

Part Number	Inductance (nH)	Test Frequency (MHz)	Rated Current (mA)	DC Resistance (ohm)	Q (min.)	Test Frequency (MHz)	Self Resonance Frequency (min.) (MHz)
LQP15MN2N3W02	2.3 ±0.05nH	500	220	0.3 max.	13	500	6000
LQP15MN2N4B02	2.4 ±0.1nH	500	220	0.3 max.	13	500	6000
LQP15MN2N4W02	2.4 ±0.05nH	500	220	0.3 max.	13	500	6000
LQP15MN2N5W02	2.5 ±0.05nH	500	220	0.3 max.	13	500	6000
LQP15MN2N6W02	2.6 ±0.05nH	500	220	0.3 max.	13	500	6000
LQP15MN2N7B02	2.7 ±0.1nH	500	220	0.3 max.	13	500	6000
LQP15MN2N7W02	2.7 ±0.05nH	500	220	0.3 max.	13	500	6000
LQP15MN2N8W02	2.8 ±0.05nH	500	190	0.4 max.	13	500	6000
LQP15MN2N9W02	2.9 ±0.05nH	500	190	0.4 max.	13	500	6000
LQP15MN3N0B02	3.0 ±0.1nH	500	190	0.4 max.	13	500	6000
LQP15MN3N0W02	3.0 ±0.05nH	500	190	0.4 max.	13	500	6000
LQP15MN3N1W02	3.1 ±0.05nH	500	190	0.4 max.	13	500	6000
LQP15MN3N2W02	3.2 ±0.05nH	500	190	0.4 max.	13	500	6000
LQP15MN3N3B02	3.3 ±0.1nH	500	190	0.4 max.	13	500	6000
LQP15MN3N3W02	3.3 ±0.05nH	500	190	0.4 max.	13	500	6000
LQP15MN3N4W02	3.4 ±0.05nH	500	170	0.5 max.	13	500	6000
LQP15MN3N5W02	3.5 ±0.05nH	500	170	0.5 max.	13	500	6000
LQP15MN3N6B02	3.6 ±0.1nH	500	170	0.5 max.	13	500	6000
LQP15MN3N6W02	3.6 ±0.05nH	500	170	0.5 max.	13	500	6000
LQP15MN3N7W02	3.7 ±0.05nH	500	170	0.5 max.	13	500	6000
LQP15MN3N8W02	3.8 ±0.05nH	500	170	0.5 max.	13	500	6000
LQP15MN3N9B02	3.9 ±0.1nH	500	170	0.5 max.	13	500	6000
LQP15MN3N9W02	3.9 ±0.05nH	500	170	0.5 max.	13	500	6000
LQP15MN4N3B02	4.3 ±0.1nH	500	160	0.6 max.	13	500	6000
LQP15MN4N7B02	4.7 ±0.1nH	500	160	0.6 max.	13	500	6000
LQP15MN5N1B02	5.1 ±0.1nH	500	140	0.7 max.	13	500	6000
LQP15MN5N6B02	5.6 ±0.1nH	500	140	0.7 max.	13	500	6000
LQP15MN6N2B02	6.2 ±0.1nH	500	130	0.9 max.	13	500	6000
LQP15MN6N8B02	6.8 ±0.1nH	500	130	0.9 max.	13	500	6000
LQP15MN7N5B02	7.5 ±0.1nH	500	110	1.1 max.	13	500	5500
LQP15MN8N2B02	8.2 ±0.1nH	500	110	1.1 max.	13	500	5500
LQP15MN9N1B02	9.1 ±0.1nH	500	100	1.3 max.	13	500	4500
LQP15MN10NG02	10 ±2%	500	100	1.3 max.	13	500	4500
LQP15MN12NG02	12 ±2%	500	90	1.6 max.	13	500	3700
LQP15MN15NG02	15 ±2%	500	90	1.8 max.	13	500	3300
LQP15MN18NG02	18 ±2%	500	80	2.0 max.	13	500	3100
LQP15MN22NG02	22 ±2%	500	70	2.6 max.	13	500	2800
LQP15MN27NG02	27 ±2%	500	70	3.1 max.	13	500	2500
LQP15MN33NG02	33 ±2%	500	60	3.8 max.	13	500	2100

Operating Temperature Range: -40 to +85°C
Only for reflow soldering.

● LQP18M Series (0603)

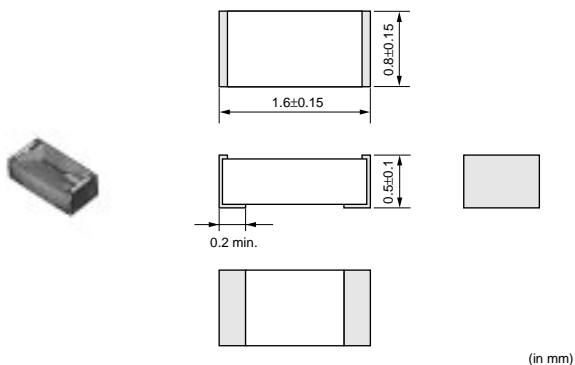

3 Inductors (Coils)

Part Number	Inductance (nH)	Test Frequency (MHz)	Rated Current (mA)	DC Resistance (ohm)	Q (min.)	Test Frequency (MHz)	Self Resonance Frequency (min.) (MHz)
LQP18MN1N3C02	1.3 ±0.2nH	500	300	0.3 max.	17	500	6000
LQP18MN1N5C02	1.5 ±0.2nH	500	300	0.3 max.	17	500	6000
LQP18MN1N8C02	1.8 ±0.2nH	500	250	0.4 max.	17	500	6000
LQP18MN2N2C02	2.2 ±0.2nH	500	250	0.4 max.	17	500	6000
LQP18MN2N7C02	2.7 ±0.2nH	500	250	0.4 max.	17	500	6000
LQP18MN3N3C02	3.3 ±0.2nH	500	250	0.4 max.	17	500	6000
LQP18MN3N9C02	3.9 ±0.2nH	500	200	0.5 max.	17	500	5900
LQP18MN4N7C02	4.7 ±0.2nH	500	200	0.5 max.	17	500	5200
LQP18MN5N6C02	5.6 ±0.2nH	500	200	0.6 max.	17	500	4700
LQP18MN6N8C02	6.8 ±0.2nH	500	200	0.7 max.	17	500	4300
LQP18MN8N2C02	8.2 ±0.2nH	500	150	0.8 max.	17	500	3600
LQP18MN10NG02	10 ±2%	500	150	1.0 max.	17	500	3400
LQP18MN12NG02	12 ±2%	500	150	1.0 max.	17	500	3000
LQP18MN15NG02	15 ±2%	500	150	1.3 max.	17	500	2700
LQP18MN18NG02	18 ±2%	500	100	1.5 max.	17	500	2300
LQP18MN22NG02	22 ±2%	500	100	1.9 max.	17	500	2100
LQP18MN27NG02	27 ±2%	500	100	2.4 max.	17	500	1900
LQP18MN33NG02	33 ±2%	500	100	2.8 max.	17	500	1700
LQP18MN39NG02	39 ±2%	500	100	2.8 max.	17	500	1400
LQP18MN47NG02	47 ±2%	300	100	2.2 max.	17	300	1200
LQP18MN56NG02	56 ±2%	300	50	3.4 max.	17	300	1000
LQP18MN68NG02	68 ±2%	300	50	3.5 max.	17	300	900
LQP18MN82NG02	82 ±2%	300	50	4.6 max.	17	300	800
LQP18MNR10G02	100 ±2%	300	50	6.1 max.	17	300	700

Operating Temperature Range: -40 to +85°C
 Only for reflow soldering.

Chip Inductor (Chip Coil)

for General Use Wire Wound Type

● LQH31M Series (1206)

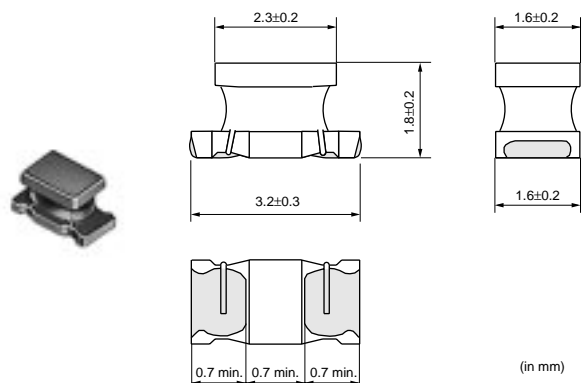

Part Number	Inductance (μH)	Test Frequency (MHz)	Rated Current (mA)	DC Resistance (ohm)	Q (min.)	Test Frequency (MHz)	Self Resonance Frequency (min.) (MHz)
LQH31MNR15K03	0.15 ±10%	1	250	0.39 ±40%	20	25	250
LQH31MNR22K03	0.22 ±10%	1	240	0.43 ±40%	20	25	250
LQH31MNR33K03	0.33 ±10%	1	230	0.45 ±40%	30	25	250
LQH31MNR47K03	0.47 ±10%	1	215	0.83 ±40%	30	25	200
LQH31MNR56K03	0.56 ±10%	1	200	0.61 ±40%	30	25	180
LQH31MNR68K03	0.68 ±10%	1	190	0.67 ±40%	30	25	160
LQH31MNR82K03	0.82 ±10%	1	185	0.73 ±40%	30	25	120
LQH31MN1R0K03	1.0 ±10%	1	175	0.49 ±30%	35	10	100
LQH31MN1R2J03	1.2 ±5%	1	165	0.37 ±30%	35	10	90
LQH31MN1R2K03	1.2 ±10%	1	165	0.9 ±30%	35	10	90
LQH31MN1R5J03	1.5 ±5%	1	155	1.0 ±30%	35	10	75
LQH31MN1R5K03	1.5 ±10%	1	155	1.0 ±30%	35	10	75
LQH31MN1R8J03	1.8 ±5%	1	150	1.6 ±30%	35	10	60
LQH31MN1R8K03	1.8 ±10%	1	150	1.6 ±30%	35	10	60
LQH31MN2R2J03	2.2 ±5%	1	140	0.7 ±30%	35	10	50
LQH31MN2R2K03	2.2 ±10%	1	140	0.7 ±30%	35	10	50
LQH31MN2R7J03	2.7 ±5%	1	135	0.55 ±30%	35	10	43
LQH31MN2R7K03	2.7 ±10%	1	135	0.55 ±30%	35	10	43
LQH31MN3R3J03	3.3 ±5%	1	130	0.61 ±30%	35	8	38
LQH31MN3R3K03	3.3 ±10%	1	130	0.61 ±30%	35	8	38
LQH31MN3R9J03	3.9 ±5%	1	125	1.5 ±30%	35	8	35
LQH31MN3R9K03	3.9 ±10%	1	125	1.5 ±30%	35	8	35
LQH31MN4R7J03	4.7 ±5%	1	120	1.7 ±30%	35	8	31
LQH31MN4R7K03	4.7 ±10%	1	120	1.7 ±30%	35	8	31
LQH31MN5R6J03	5.6 ±5%	1	115	1.8 ±30%	35	8	28
LQH31MN5R6K03	5.6 ±10%	1	115	1.8 ±30%	35	8	28
LQH31MN6R8J03	6.8 ±5%	1	110	2.0 ±30%	35	8	25
LQH31MN6R8K03	6.8 ±10%	1	110	2.0 ±30%	35	8	25
LQH31MN8R2J03	8.2 ±5%	1	105	2.2 ±30%	35	8	23
LQH31MN8R2K03	8.2 ±10%	1	105	2.2 ±30%	35	8	23
LQH31MN100J03	10 ±5%	1	100	2.5 ±30%	35	5	20
LQH31MN100K03	10 ±10%	1	100	2.5 ±30%	35	5	20
LQH31MN120J03	12 ±5%	1	95	2.7 ±30%	35	5	18
LQH31MN120K03	12 ±10%	1	95	2.7 ±30%	35	5	18
LQH31MN150J03	15 ±5%	1	90	3.0 ±30%	35	5	16
LQH31MN150K03	15 ±10%	1	90	3.0 ±30%	35	5	16
LQH31MN180J03	18 ±5%	1	85	3.4 ±30%	35	5	15
LQH31MN180K03	18 ±10%	1	85	3.4 ±30%	35	5	15
LQH31MN220J03	22 ±5%	1	85	3.1 ±30%	40	2.5	14

Continued on the following page.

△Note • This PDF catalog is downloaded from the website of Murata Manufacturing co., Ltd. Therefore, it's specifications are subject to change or our products in it may be discontinued without advance notice. Please check with our sales representatives or product engineers before ordering.
• This PDF catalog has only typical specifications because there is no space for detailed specifications. Therefore, please approve our product specifications or transact the approval sheet for product specifications before ordering.

Continued from the preceding page.

Part Number	Inductance (μH)	Test Frequency (MHz)	Rated Current (mA)	DC Resistance (ohm)	Q (min.)	Test Frequency (MHz)	Self Resonance Frequency (min.) (MHz)
LQH31MN220K03	22 ±10%	1	85	3.1 ±30%	40	2.5	14
LQH31MN270J03	27 ±5%	1	85	3.4 ±30%	40	2.5	13
LQH31MN270K03	27 ±10%	1	85	3.4 ±30%	40	2.5	13
LQH31MN330J03	33 ±5%	1	80	3.8 ±30%	40	2.5	12
LQH31MN330K03	33 ±10%	1	80	3.8 ±30%	40	2.5	12
LQH31MN390J03	39 ±5%	1	55	7.2 ±30%	40	2.5	11
LQH31MN390K03	39 ±10%	1	55	7.2 ±30%	40	2.5	11
LQH31MN470J03	47 ±5%	1	55	8.0 ±30%	40	2.5	10
LQH31MN470K03	47 ±10%	1	55	8.0 ±30%	40	2.5	10
LQH31MN560J03	56 ±5%	1	50	8.9 ±30%	40	2.5	9
LQH31MN560K03	56 ±10%	1	50	8.9 ±30%	40	2.5	9
LQH31MN680J03	68 ±5%	1	50	9.9 ±30%	40	2.5	8.5
LQH31MN680K03	68 ±10%	1	50	9.9 ±30%	40	2.5	8.5
LQH31MN820J03	82 ±5%	1	45	11 ±30%	40	2.5	7.5
LQH31MN820K03	82 ±10%	1	45	11 ±30%	40	2.5	7.5
LQH31MN101J03	100 ±5%	1	45	12 ±30%	40	2.5	7
LQH31MN101K03	100 ±10%	1	45	12 ±30%	40	2.5	7

Operating Temperature Range: -40 to +85°C

● LQH32M Series (1210)

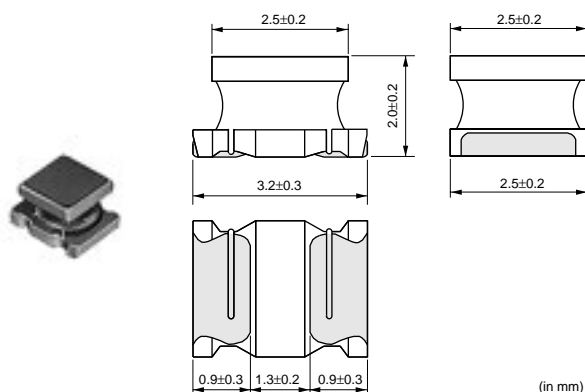

Part Number	Inductance (μH)	Test Frequency	Rated Current (mA)	DC Resistance (ohm)	Q (min.)	Test Frequency	Self Resonance Frequency (min.) (MHz)
LQH32MN1R0M23	1.0 ±20%	1MHz	445	0.5 max.	20	1MHz	100
LQH32MN1R2M23	1.2 ±20%	1MHz	425	0.6 max.	20	1MHz	100
LQH32MN1R5K23	1.5 ±10%	1MHz	400	0.6 max.	20	1MHz	75
LQH32MN1R8K23	1.8 ±10%	1MHz	390	0.7 max.	20	1MHz	60
LQH32MN2R2K23	2.2 ±10%	1MHz	370	0.8 max.	20	1MHz	50
LQH32MN2R7K23	2.7 ±10%	1MHz	320	0.9 max.	20	1MHz	43
LQH32MN3R3K23	3.3 ±10%	1MHz	300	1.0 max.	20	1MHz	38
LQH32MN3R9K23	3.9 ±10%	1MHz	290	1.1 max.	20	1MHz	35
LQH32MN4R7K23	4.7 ±10%	1MHz	270	1.2 max.	20	1MHz	31
LQH32MN5R6K23	5.6 ±10%	1MHz	250	1.3 max.	20	1MHz	28
LQH32MN6R8K23	6.8 ±10%	1MHz	240	1.5 max.	20	1MHz	25
LQH32MN8R2K23	8.2 ±10%	1MHz	225	1.6 max.	20	1MHz	23
LQH32MN100J23	10 ±5%	1MHz	190	1.8 max.	35	1MHz	20
LQH32MN100K23	10 ±10%	1MHz	190	1.8 max.	35	1MHz	20
LQH32MN120J23	12 ±5%	1MHz	180	2.0 max.	35	1MHz	18
LQH32MN120K23	12 ±10%	1MHz	180	2.0 max.	35	1MHz	18
LQH32MN150J23	15 ±5%	1MHz	170	2.2 max.	35	1MHz	16
LQH32MN150K23	15 ±10%	1MHz	170	2.2 max.	35	1MHz	16
LQH32MN180J23	18 ±5%	1MHz	165	2.5 max.	35	1MHz	15

Continued on the following page.

 Continued from the preceding page.

Part Number	Inductance (μH)	Test Frequency	Rated Current (mA)	DC Resistance (ohm)	Q (min.)	Test Frequency	Self Resonance Frequency (min.) (MHz)
LQH32MN180K23	18 ±10%	1MHz	165	2.5 max.	35	1MHz	15
LQH32MN220J23	22 ±5%	1MHz	150	2.8 max.	35	1MHz	14
LQH32MN220K23	22 ±10%	1MHz	150	2.8 max.	35	1MHz	14
LQH32MN270J23	27 ±5%	1MHz	125	3.1 max.	35	1MHz	13
LQH32MN270K23	27 ±10%	1MHz	125	3.1 max.	35	1MHz	13
LQH32MN330J23	33 ±5%	1MHz	115	3.5 max.	40	1MHz	12
LQH32MN330K23	33 ±10%	1MHz	115	3.5 max.	40	1MHz	12
LQH32MN390J23	39 ±5%	1MHz	110	3.9 max.	40	1MHz	11
LQH32MN390K23	39 ±10%	1MHz	110	3.9 max.	40	1MHz	11
LQH32MN470J23	47 ±5%	1MHz	100	4.3 max.	40	1MHz	11
LQH32MN470K23	47 ±10%	1MHz	100	4.3 max.	40	1MHz	11
LQH32MN560J23	56 ±5%	1MHz	85	4.9 max.	40	1MHz	10
LQH32MN560K23	56 ±10%	1MHz	85	4.9 max.	40	1MHz	10
LQH32MN680J23	68 ±5%	1MHz	80	5.5 max.	40	1MHz	9
LQH32MN680K23	68 ±10%	1MHz	80	5.5 max.	40	1MHz	9
LQH32MN820J23	82 ±5%	1MHz	70	6.2 max.	40	1MHz	8.5
LQH32MN820K23	82 ±10%	1MHz	70	6.2 max.	40	1MHz	8.5
LQH32MN101J23	100 ±5%	1MHz	80	7.0 max.	40	796kHz	8
LQH32MN101K23	100 ±10%	1MHz	80	7.0 max.	40	796kHz	8
LQH32MN121J23	120 ±5%	1MHz	75	8.0 max.	40	796kHz	7.5
LQH32MN121K23	120 ±10%	1MHz	75	8.0 max.	40	796kHz	7.5
LQH32MN151J23	150 ±5%	1MHz	70	9.3 max.	40	796kHz	7
LQH32MN151K23	150 ±10%	1MHz	70	9.3 max.	40	796kHz	7
LQH32MN181J23	180 ±5%	1MHz	65	10.2 max.	40	796kHz	6
LQH32MN181K23	180 ±10%	1MHz	65	10.2 max.	40	796kHz	6
LQH32MN221J23	220 ±5%	1MHz	65	11.8 max.	40	796kHz	5.5
LQH32MN221K23	220 ±10%	1MHz	65	11.8 max.	40	796kHz	5.5
LQH32MN271J23	270 ±5%	1MHz	65	12.5 max.	40	796kHz	5
LQH32MN271K23	270 ±10%	1MHz	65	12.5 max.	40	796kHz	5
LQH32MN331J23	330 ±5%	1MHz	65	13.0 max.	40	796kHz	5
LQH32MN331K23	330 ±10%	1MHz	65	13.0 max.	40	796kHz	5
LQH32MN391J23	390 ±5%	1MHz	50	22.0 max.	50	796kHz	5
LQH32MN391K23	390 ±10%	1MHz	50	22.0 max.	50	796kHz	5
LQH32MN471J23	470 ±5%	1kHz	45	25.0 max.	50	796kHz	5
LQH32MN471K23	470 ±10%	1kHz	45	25.0 max.	50	796kHz	5
LQH32MN561J23	560 ±5%	1kHz	40	28.0 max.	50	796kHz	5
LQH32MN561K23	560 ±10%	1kHz	40	28.0 max.	50	796kHz	5

Operating Temperature Range: -40 to +85°C

● LQH43M/N Series (1812)

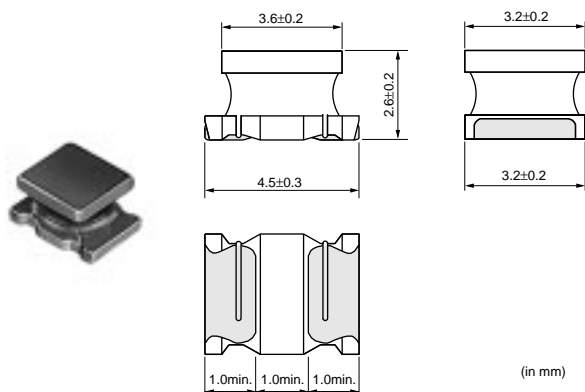

△Note • This PDF catalog is downloaded from the website of Murata Manufacturing co., ltd. Therefore, it's specifications are subject to change or our products in it may be discontinued without advance notice. Please check with our sales representatives or product engineers before ordering.
• This PDF catalog has only typical specifications because there is no space for detailed specifications. Therefore, please approve our product specifications or transact the approval sheet for product specifications before ordering.

Part Number	Inductance (μH)	Test Frequency	Rated Current (mA)	DC Resistance (ohm)	Q (min.)	Test Frequency	Self Resonance Frequency (min.) (MHz)
LQH43MN1R0M03	1.0 ±20%	1MHz	500	0.20 max.	20	1MHz	120
LQH43MN1R2M03	1.2 ±20%	1MHz	500	0.20 max.	20	1MHz	100
LQH43MN1R5M03	1.5 ±20%	1MHz	500	0.30 max.	20	1MHz	85
LQH43MN1R8M03	1.8 ±20%	1MHz	500	0.30 max.	20	1MHz	75
LQH43MN2R2M03	2.2 ±20%	1MHz	500	0.30 max.	20	1MHz	62
LQH43MN2R7M03	2.7 ±20%	1MHz	500	0.32 max.	20	1MHz	53
LQH43MN3R3M03	3.3 ±20%	1MHz	500	0.35 max.	20	1MHz	47
LQH43MN3R9M03	3.9 ±20%	1MHz	500	0.38 max.	20	1MHz	41
LQH43MN4R7K03	4.7 ±10%	1MHz	500	0.40 max.	30	1MHz	38
LQH43MN5R6K03	5.6 ±10%	1MHz	500	0.47 max.	30	1MHz	33
LQH43MN6R8K03	6.8 ±10%	1MHz	450	0.50 max.	30	1MHz	31
LQH43MN8R2K03	8.2 ±10%	1MHz	450	0.56 max.	30	1MHz	27
LQH43MN100J03	10 ±5%	1MHz	400	0.56 max.	35	1MHz	23
LQH43MN100K03	10 ±10%	1MHz	400	0.56 max.	35	1MHz	23
LQH43MN120J03	12 ±5%	1MHz	380	0.62 max.	35	1MHz	21
LQH43MN120K03	12 ±10%	1MHz	380	0.62 max.	35	1MHz	21
LQH43MN150J03	15 ±5%	1MHz	360	0.73 max.	35	1MHz	19
LQH43MN150K03	15 ±10%	1MHz	360	0.73 max.	35	1MHz	19
LQH43MN180J03	18 ±5%	1MHz	340	0.82 max.	35	1MHz	17
LQH43MN180K03	18 ±10%	1MHz	340	0.82 max.	35	1MHz	17
LQH43MN220J03	22 ±5%	1MHz	320	0.94 max.	35	1MHz	15
LQH43MN220K03	22 ±10%	1MHz	320	0.94 max.	35	1MHz	15
LQH43MN270J03	27 ±5%	1MHz	300	1.1 max.	35	1MHz	14
LQH43MN270K03	27 ±10%	1MHz	300	1.1 max.	35	1MHz	14
LQH43MN330J03	33 ±5%	1MHz	270	1.2 max.	35	1MHz	12
LQH43MN330K03	33 ±10%	1MHz	270	1.2 max.	35	1MHz	12
LQH43MN390J03	39 ±5%	1MHz	240	1.4 max.	35	1MHz	11
LQH43MN390K03	39 ±10%	1MHz	240	1.4 max.	35	1MHz	11
LQH43MN470J03	47 ±5%	1MHz	220	1.5 max.	35	1MHz	10
LQH43MN470K03	47 ±10%	1MHz	220	1.5 max.	35	1MHz	10
LQH43MN560J03	56 ±5%	1MHz	200	1.7 max.	35	1MHz	9.3
LQH43MN560K03	56 ±10%	1MHz	200	1.7 max.	35	1MHz	9.3
LQH43MN680J03	68 ±5%	1MHz	180	1.9 max.	35	1MHz	8.4
LQH43MN680K03	68 ±10%	1MHz	180	1.9 max.	35	1MHz	8.4
LQH43MN820J03	82 ±5%	1MHz	170	2.2 max.	35	1MHz	7.5
LQH43MN820K03	82 ±10%	1MHz	170	2.2 max.	35	1MHz	7.5
LQH43MN101J03	100 ±5%	1MHz	160	2.5 max.	40	796kHz	6.8
LQH43MN101K03	100 ±10%	1MHz	160	2.5 max.	40	796kHz	6.8
LQH43MN121J03	120 ±5%	1MHz	150	3.0 max.	40	796kHz	6.2
LQH43MN121K03	120 ±10%	1MHz	150	3.0 max.	40	796kHz	6.2
LQH43MN151J03	150 ±5%	1MHz	130	3.7 max.	40	796kHz	5.5
LQH43MN151K03	150 ±10%	1MHz	130	3.7 max.	40	796kHz	5.5
LQH43MN181J03	180 ±5%	1MHz	120	4.5 max.	40	796kHz	5
LQH43MN181K03	180 ±10%	1MHz	120	4.5 max.	40	796kHz	5
LQH43MN221J03	220 ±5%	1MHz	110	5.4 max.	40	796kHz	4.5
LQH43MN221K03	220 ±10%	1MHz	110	5.4 max.	40	796kHz	4.5
LQH43MN271J03	270 ±5%	1MHz	100	6.8 max.	40	796kHz	4
LQH43MN271K03	270 ±10%	1MHz	100	6.8 max.	40	796kHz	4
LQH43MN331J03	330 ±5%	1MHz	95	8.2 max.	40	796kHz	3.6
LQH43MN331K03	330 ±10%	1MHz	95	8.2 max.	40	796kHz	3.6
LQH43MN391J03	390 ±5%	1MHz	90	9.7 max.	40	796kHz	3.3
LQH43MN391K03	390 ±10%	1MHz	90	9.7 max.	40	796kHz	3.3
LQH43MN471J03	470 ±5%	1kHz	80	11.8 max.	40	796kHz	3
LQH43MN471K03	470 ±10%	1kHz	80	11.8 max.	40	796kHz	3
LQH43MN561J03	560 ±5%	1kHz	70	14.5 max.	40	796kHz	2.7

Continued on the following page.

Continued from the preceding page.

Part Number	Inductance (μH)	Test Frequency	Rated Current (mA)	DC Resistance (ohm)	Q (min.)	Test Frequency	Self Resonance Frequency (min.) (MHz)
LQH43MN561K03	560 ±10%	1kHz	70	14.5 max.	40	796kHz	2.7
LQH43MN681J03	680 ±5%	1kHz	65	17.0 max.	40	796kHz	2.5
LQH43MN681K03	680 ±10%	1kHz	65	17.0 max.	40	796kHz	2.5
LQH43MN821J03	820 ±5%	1kHz	60	20.5 max.	40	796kHz	2.2
LQH43MN821K03	820 ±10%	1kHz	60	20.5 max.	40	796kHz	2.2
LQH43MN102J03	1000 ±5%	1kHz	50	25.0 max.	40	252kHz	2
LQH43MN102K03	1000 ±10%	1kHz	50	25.0 max.	40	252kHz	2
LQH43MN122J03	1200 ±5%	1kHz	45	30.0 max.	40	252kHz	1.8
LQH43MN122K03	1200 ±10%	1kHz	45	30.0 max.	40	252kHz	1.8
LQH43MN152J03	1500 ±5%	1kHz	40	37.0 max.	40	252kHz	1.6
LQH43MN152K03	1500 ±10%	1kHz	40	37.0 max.	40	252kHz	1.6
LQH43NN182J03	1800 ±5%	1kHz	35	45.0 max.	40	252kHz	1.5
LQH43NN182K03	1800 ±10%	1kHz	35	45.0 max.	40	252kHz	1.5
LQH43NN222J03	2200 ±5%	1kHz	30	50.0 max.	40	252kHz	1.3
LQH43NN222K03	2200 ±10%	1kHz	30	50.0 max.	40	252kHz	1.3

Operating Temperature Range: -40 to +85°C

Chip Inductor (Chip Coil)

for General Use Multilayer Type

● LQM18N Series (0603)

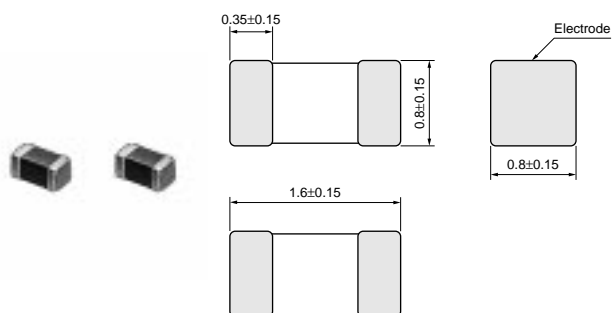

(in mm)

Part Number	Inductance (nH)	Test Frequency (MHz)	Rated Current (mA)	DC Resistance (ohm)	Q (min.)	Test Frequency (MHz)	Self Resonance Frequency (min.) (MHz)
LQM18NN47NM00	47 ±20%	50	50	0.30 max.	10	50	260
LQM18NN68NM00	68 ±20%	50	50	0.30 max.	10	50	250
LQM18NN82NM00	82 ±20%	50	50	0.30 max.	10	50	245
LQM18NNR10K00	100 ±10%	25	50	0.50 max.	15	25	240
LQM18NNR12K00	120 ±10%	25	50	0.50 max.	15	25	205
LQM18NNR15K00	150 ±10%	25	50	0.60 max.	15	25	180
LQM18NNR18K00	180 ±10%	25	50	0.60 max.	15	25	165
LQM18NNR22K00	220 ±10%	25	50	0.80 max.	15	25	150
LQM18NNR27K00	270 ±10%	25	50	0.80 max.	15	25	136
LQM18NNR33K00	330 ±10%	25	35	0.85 max.	15	25	125
LQM18NNR39K00	390 ±10%	25	35	1.00 max.	15	25	110
LQM18NNR47K00	470 ±10%	25	35	1.35 max.	15	25	105
LQM18NNR56K00	560 ±10%	25	35	1.55 max.	15	25	95
LQM18NNR68K00	680 ±10%	25	35	1.70 max.	15	25	90
LQM18NNR82K00	820 ±10%	25	35	2.10 max.	15	25	85
LQM18NN1R0K00	1000 ±10%	10	25	0.60 max.	35	10	75
LQM18NN1R2K00	1200 ±10%	10	25	0.80 max.	35	10	65

Continued on the following page.

Note • This PDF catalog is downloaded from the website of Murata Manufacturing co., Ltd. Therefore, its specifications are subject to change or our products in it may be discontinued without advance notice. Please check with our sales representatives or product engineers before ordering.
 • This PDF catalog has only typical specifications because there is no space for detailed specifications. Therefore, please approve our product specifications or transact the approval sheet for product specifications before ordering.

Continued from the preceding page.

Part Number	Inductance (nH)	Test Frequency (MHz)	Rated Current (mA)	DC Resistance (ohm)	Q (min.)	Test Frequency (MHz)	Self Resonance Frequency (min.) (MHz)
LQM18NN1R5K00	1500 ±10%	10	25	0.80 max.	35	10	60
LQM18NN1R8K00	1800 ±10%	10	25	0.95 max.	35	10	55
LQM18NN2R2K00	2200 ±10%	10	15	1.15 max.	35	10	50

Operating Temperature Range: -40 to +85°C

● LQM21N Series (0805)

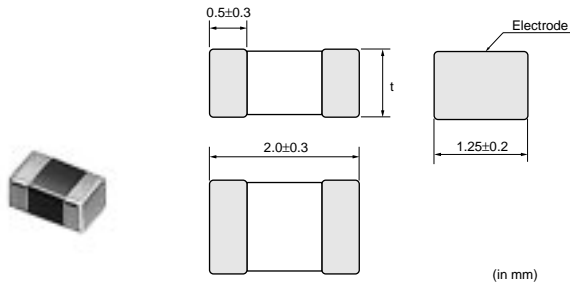

Dimension of t	Inductance: 0.1 to 2.2μH	0.85±0.2
		Inductance: 2.7 to 4.7μH

Part Number	Inductance (μH)	Test Frequency (MHz)	Rated Current (mA)	DC Resistance (ohm)	Q (min.)	Test Frequency (MHz)	Self Resonance Frequency (min.) (MHz)
LQM21NNR10K10	0.1 ±10%	25	250	0.26 max.	20	25	340
LQM21NNR12K10	0.12 ±10%	25	250	0.29 max.	20	25	310
LQM21NNR15K10	0.15 ±10%	25	250	0.32 max.	20	25	270
LQM21NNR18K10	0.18 ±10%	25	250	0.35 max.	20	25	250
LQM21NNR22K10	0.22 ±10%	25	250	0.38 max.	20	25	220
LQM21NNR27K10	0.27 ±10%	25	250	0.42 max.	20	25	200
LQM21NNR33K10	0.33 ±10%	25	250	0.48 max.	20	25	180
LQM21NNR39K10	0.39 ±10%	25	200	0.53 max.	25	25	165
LQM21NNR47K10	0.47 ±10%	25	200	0.57 max.	25	25	150
LQM21NNR56K10	0.56 ±10%	25	150	0.63 max.	25	25	140
LQM21NNR68K10	0.68 ±10%	25	150	0.72 max.	25	25	125
LQM21NNR82K10	0.82 ±10%	25	150	0.81 max.	25	25	115
LQM21NN1R0K10	1 ±10%	10	50	0.40 max.	45	10	107
LQM21NN1R2K10	1.2 ±10%	10	50	0.47 max.	45	10	97
LQM21NN1R5K10	1.5 ±10%	10	50	0.50 max.	45	10	87
LQM21NN1R8K10	1.8 ±10%	10	50	0.57 max.	45	10	80
LQM21NN2R2K10	2.2 ±10%	10	30	0.63 max.	45	10	71
LQM21NN2R7K10	2.7 ±10%	10	30	0.69 max.	45	10	66
LQM21NN3R3K10	3.3 ±10%	10	30	0.80 max.	45	10	59
LQM21NN3R9K10	3.9 ±10%	10	30	0.89 max.	45	10	53
LQM21NN4R7K10	4.7 ±10%	10	30	1.00 max.	45	10	47

Operating Temperature Range: -40 to +85°C

Chip Inductor (Chip Coil)

for DC-DC Converter Wire Wound Type

● LQH2MC_02/LQH2MC_52 Series

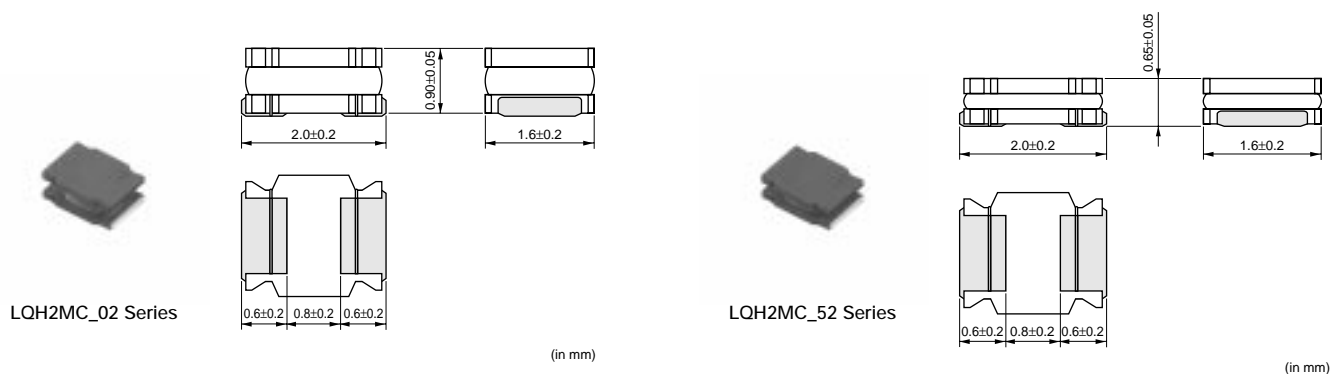

Part Number	Inductance (μH)	Test Frequency (MHz)	Allowable DC Current (Based on Temperature Rise) (mA)	Allowable DC Current (Based on Inductance Change)	DC Resistance (ohm)	Self Resonance Frequency (min.) (MHz)
LQH2MCN1R0M02	1.0 ±20%	1	485	-	0.30 ±30%	100
LQH2MCN1R5M02	1.5 ±20%	1	445	-	0.40 ±30%	95
LQH2MCN2R2M02	2.2 ±20%	1	425	-	0.48 ±30%	70
LQH2MCN3R3M02	3.3 ±20%	1	375	-	0.60 ±30%	65
LQH2MCN4R7M02	4.7 ±20%	1	300	-	0.8 ±30%	60
LQH2MCN5R6M02	5.6 ±20%	1	280	-	0.9 ±30%	60
LQH2MCN6R8M02	6.8 ±20%	1	255	-	1.0 ±30%	55
LQH2MCN8R2M02	8.2 ±20%	1	235	-	1.1 ±30%	50
LQH2MCN100K02	10 ±10%	1	225	-	1.2 ±30%	48
LQH2MCN120K02	12 ±10%	1	210	-	1.4 ±30%	44
LQH2MCN150K02	15 ±10%	1	200	-	1.6 ±30%	40
LQH2MCN180K02	18 ±10%	1	190	-	1.8 ±30%	35
LQH2MCN220K02	22 ±10%	1	185	-	2.1 ±30%	30
LQH2MCN270K02	27 ±10%	1	180	-	2.5 ±30%	30
LQH2MCN330K02	33 ±10%	1	160	-	2.8 ±30%	28
LQH2MCN390K02	39 ±10%	1	125	-	4.4 ±30%	24
LQH2MCN470K02	47 ±10%	1	120	-	5.1 ±30%	18
LQH2MCN560K02	56 ±10%	1	110	-	5.7 ±30%	17
LQH2MCN680K02	68 ±10%	1	100	-	6.6 ±30%	14
LQH2MCN820K02	82 ±10%	1	90	-	7.5 ±30%	14
LQH2MCN1R0M52	1.0 ±20%	1	595	-	0.25 ±30%	215
LQH2MCN1R5M52	1.5 ±20%	1	540	-	0.33 ±30%	165
LQH2MCN2R2M52	2.2 ±20%	1	500	-	0.42 ±30%	125
LQH2MCN3R3M52	3.3 ±20%	1	360	-	0.74 ±30%	110
LQH2MCN4R7M52	4.7 ±20%	1	335	-	0.91 ±30%	90
LQH2MCN6R8M52	6.8 ±20%	1	285	-	1.23 ±30%	65
LQH2MCN100M52	10 ±20%	1	200	-	2.27 ±30%	60
LQH2MCN120M52	12 ±20%	1	170	-	2.4 ±30%	30
LQH2MCN150M52	15 ±20%	1	150	-	3.5 ±30%	30
LQH2MCN180M52	18 ±20%	1	140	-	4 ±30%	30
LQH2MCN220M52	22 ±20%	1	130	-	5.5 ±30%	30

Operating Temperature Range: -40°C to +85°C

Only for reflow soldering.

△Note • This PDF catalog is downloaded from the website of Murata Manufacturing co., ltd. Therefore, it's specifications are subject to change or our products in it may be discontinued without advance notice. Please check with our sales representatives or product engineers before ordering.
• This PDF catalog has only typical specifications because there is no space for detailed specifications. Therefore, please approve our product specifications or transact the approval sheet for product specifications before ordering.

● LQH32P Series

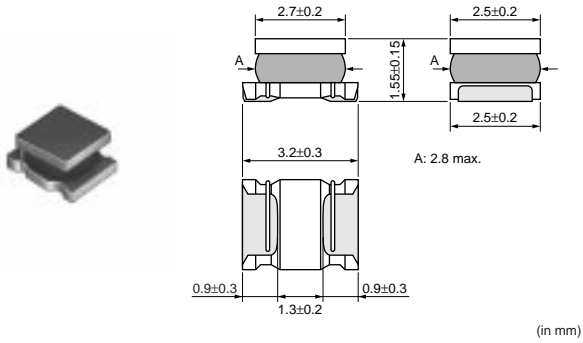

Part Number	Inductance (μH)	Test Frequency (MHz)	Allowable DC Current (Based on Temperature Rise) (mA)	Allowable DC Current (Based on Inductance Change) (mA)	DC Resistance (ohm)	Self Resonance Frequency (min.) (MHz)
LQH32PNR47NN0	$0.47 \pm 30\%$	1	2550	3400	$0.03 \pm 20\%$	100
LQH32PN1R0NN0	$1.0 \pm 30\%$	1	2050	2300	$0.045 \pm 20\%$	100
LQH32PN1R5NN0	$1.5 \pm 30\%$	1	1750	1750	$0.057 \pm 20\%$	70
LQH32PN2R2NN0	$2.2 \pm 30\%$	1	1600	1550	$0.076 \pm 20\%$	70
LQH32PN3R3NN0	$3.3 \pm 30\%$	1	1200	1250	$0.12 \pm 20\%$	50
LQH32PN4R7NN0	$4.7 \pm 30\%$	1	1000	1000	$0.18 \pm 20\%$	40
LQH32PN6R8NN0	$6.8 \pm 30\%$	1	850	850	$0.24 \pm 20\%$	40
LQH32PN100MN0	$10 \pm 20\%$	1	700	750	$0.38 \pm 20\%$	30
LQH32PN220MN0	$22 \pm 20\%$	1	450	500	$0.81 \pm 20\%$	20

Operating Temperature Range: -40°C to $+85^\circ\text{C}$
 Only for reflow soldering.

● LQH3NP Series

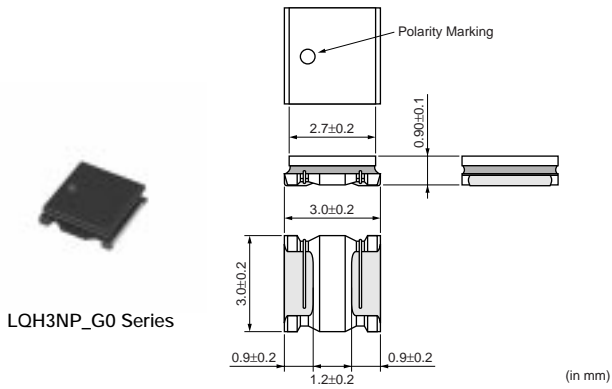

LQH3NP_G0 Series

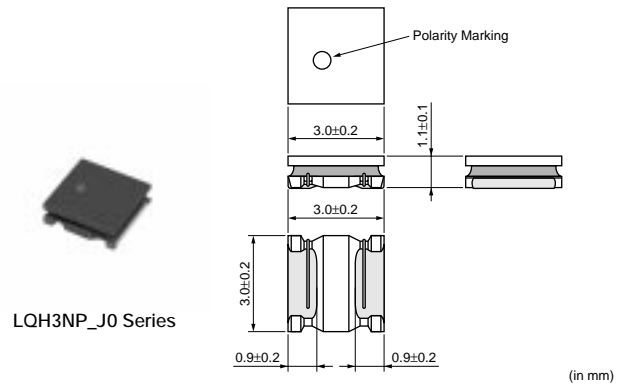

LQH3NP_J0 Series

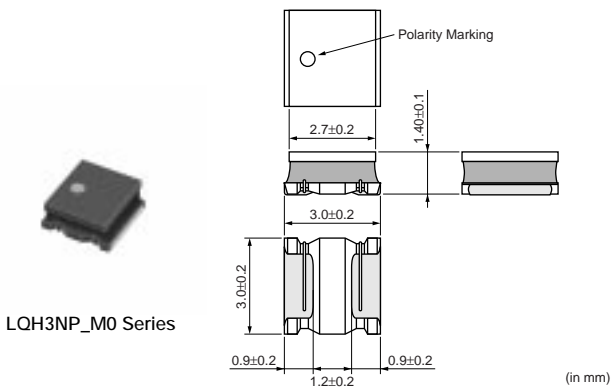

LQH3NP_M0 Series

Note • This PDF catalog is downloaded from the website of Murata Manufacturing co., Ltd. Therefore, it's specifications are subject to change or our products in it may be discontinued without advance notice. Please check with our sales representatives or product engineers before ordering.
 • This PDF catalog has only typical specifications because there is no space for detailed specifications. Therefore, please approve our product specifications or transact the approval sheet for product specifications before ordering.

Part Number	Inductance (μH)	Test Frequency (MHz)	Allowable DC Current (Based on Temperature Rise) (mA)	Allowable DC Current (Based on Inductance Change) (mA)	DC Resistance (ohm)	Self Resonance Frequency (min.) (MHz)
LQH3NPN1R0NG0	1.0 ±30%	1	1525	1650	0.08 ±20%	160
LQH3NPN1R5NG0	1.5 ±30%	1	1470	1300	0.10 ±20%	130
LQH3NPN2R2NG0	2.2 ±30%	1	1270	1250	0.14 ±20%	100
LQH3NPN3R3NG0	3.3 ±30%	1	1130	850	0.18 ±20%	75
LQH3NPN4R7NG0	4.7 ±30%	1	925	800	0.26 ±20%	60
LQH3NPN6R8NG0	6.8 ±30%	1	710	650	0.45 ±20%	48
LQH3NPN100NG0	10 ±30%	1	630	500	0.57 ±20%	45
LQH3NPN150NG0	15 ±30%	1	475	370	0.91 ±20%	35
LQH3NPN220MG0	22 ±20%	1	430	340	1.1 ±20%	25
LQH3NPN220NG0	22 ±30%	1	430	340	1.1 ±20%	25
LQH3NPN330MG0	33 ±20%	1	345	250	2.1 ±20%	24
LQH3NPN330NG0	33 ±30%	1	345	250	2.1 ±20%	24
LQH3NPN470MG0	47 ±20%	1	270	170	3.0 ±20%	19
LQH3NPN470NG0	47 ±30%	1	270	170	3.0 ±20%	19
LQH3NPN680MG0	68 ±20%	1	235	150	4.2 ±20%	16
LQH3NPN680NG0	68 ±30%	1	235	150	4.2 ±20%	16
LQH3NPN101MG0	100 ±20%	1	165	140	8.0 ±20%	10
LQH3NPN101NG0	100 ±30%	1	165	140	8.0 ±20%	10
LQH3NPN151MG0	150 ±20%	1	145	110	11.0 ±20%	10
LQH3NPN151NG0	150 ±30%	1	145	110	11.0 ±20%	10
LQH3NPN221MG0	220 ±20%	1	130	100	14.0 ±20%	8.5
LQH3NPN221NG0	220 ±30%	1	130	100	14.0 ±20%	8.5
LQH3NPN251MG0	250 ±20%	1	130	80	15.0 ±20%	8.0
LQH3NPN251NG0	250 ±30%	1	130	80	15.0 ±20%	8.0
LQH3NPN1R0NJ0	1.0 ±30%	1	1620	1650	0.040 ±20%	140
LQH3NPN1R5NJ0	1.5 ±30%	1	1500	1200	0.055 ±20%	90
LQH3NPN2R2NJ0	2.2 ±30%	1	1460	1150	0.069 ±20%	90
LQH3NPN3R3NJ0	3.3 ±30%	1	1270	950	0.105 ±20%	70
LQH3NPN4R7NJ0	4.7 ±30%	1	1120	780	0.130 ±20%	65
LQH3NPN6R8NJ0	6.8 ±30%	1	850	700	0.210 ±20%	45
LQH3NPN100NJ0	10 ±30%	1	710	560	0.300 ±20%	35
LQH3NPN150NJ0	15 ±30%	1	590	440	0.440 ±20%	30
LQH3NPN220MJ0	22 ±20%	1	510	350	0.600 ±20%	25
LQH3NPN220NJ0	22 ±30%	1	510	350	0.600 ±20%	25
LQH3NPN330MJ0	33 ±20%	1	410	280	0.900 ±20%	20
LQH3NPN330NJ0	33 ±30%	1	410	280	0.900 ±20%	20
LQH3NPN470MJ0	47 ±20%	1	350	200	1.30 ±20%	15
LQH3NPN470NJ0	47 ±30%	1	350	200	1.30 ±20%	15
LQH3NPN1R0MM0	1.0 ±20%	1	2050	1400	0.044 ±20%	130
LQH3NPN1R0NM0	1.0 ±30%	1	2050	1400	0.044 ±20%	130
LQH3NPN2R2MM0	2.2 ±20%	1	1600	1250	0.073 ±20%	90
LQH3NPN2R2NM0	2.2 ±30%	1	1600	1250	0.073 ±20%	90
LQH3NPN3R3MM0	3.3 ±20%	1	1450	1000	0.092 ±20%	75
LQH3NPN3R3NM0	3.3 ±30%	1	1450	1000	0.092 ±20%	75
LQH3NPN4R7MM0	4.7 ±20%	1	1250	880	0.13 ±20%	65
LQH3NPN4R7NM0	4.7 ±30%	1	1250	880	0.13 ±20%	65
LQH3NPN6R8MM0	6.8 ±20%	1	1000	820	0.20 ±20%	50
LQH3NPN6R8NM0	6.8 ±30%	1	1000	820	0.20 ±20%	50
LQH3NPN100MM0	10 ±20%	1	870	550	0.26 ±20%	45
LQH3NPN100NM0	10 ±30%	1	870	550	0.26 ±20%	45
LQH3NPN220MM0	22 ±20%	1	650	410	0.51 ±20%	28
LQH3NPN330MM0	33 ±20%	1	500	370	0.85 ±20%	22
LQH3NPN470MM0	47 ±20%	1	410	310	1.25 ±20%	18
LQH3NPN101MM0	100 ±20%	1	240	200	3.50 ±20%	12

Operating Temperature Range: -40°C to +85°C

Only for reflow soldering.

△Note • This PDF catalog is downloaded from the website of Murata Manufacturing co., Ltd. Therefore, it's specifications are subject to change or our products in it may be discontinued without advance notice. Please check with our sales representatives or product engineers before ordering.
• This PDF catalog has only typical specifications because there is no space for detailed specifications. Therefore, please approve our product specifications or transact the approval sheet for product specifications before ordering.

● LQH44P Series

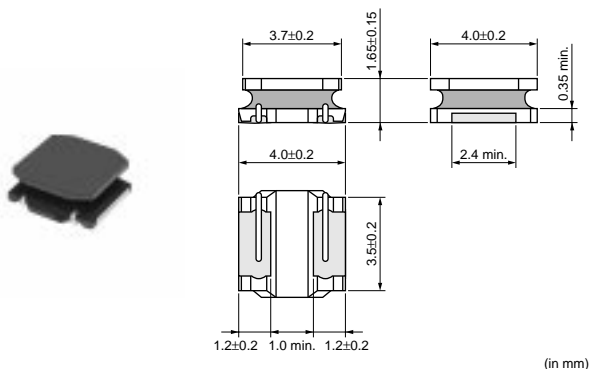

Part Number	Inductance (μH)	Test Frequency (MHz)	Allowable DC Current (Based on Temperature Rise) (mA)	Allowable DC Current (Based on Inductance Change) (mA)	DC Resistance (ohm)	Self Resonance Frequency (min.) (MHz)
LQH44PN1R0NP0	1.0 ±30%	1	2450	2950	0.030 ±20%	90
LQH44PN2R2MP0	2.2 ±20%	1	1800	2500	0.049 ±20%	70
LQH44PN3R3MP0	3.3 ±20%	1	1770	2100	0.065 ±20%	50
LQH44PN4R7MP0	4.7 ±20%	1	1700	1700	0.080 ±20%	40
LQH44PN6R8MP0	6.8 ±20%	1	1340	1400	0.12 ±20%	35
LQH44PN100MP0	10 ±20%	1	1170	1150	0.16 ±20%	25
LQH44PN220MP0	22 ±20%	1	790	800	0.37 ±20%	17

● LQH55P Series

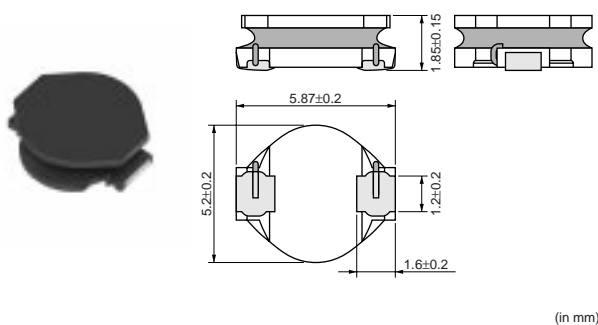

Part Number	Inductance (μH)	Test Frequency (kHz)	Allowable DC Current (Based on Temperature Rise) (mA)	Allowable DC Current (Based on Inductance Change) (mA)	DC Resistance (ohm)	Self Resonance Frequency (min.) (MHz)
LQH55PN1R2NR0	1.2 ±30%	100	2900	2600	0.021 ±20%	80
LQH55PN2R2NR0	2.2 ±30%	100	2500	2100	0.031 ±20%	60
LQH55PN2R7NR0	2.7 ±30%	100	2150	2070	0.040 ±20%	50
LQH55PN3R3NR0	3.3 ±30%	100	2000	2000	0.044 ±20%	35
LQH55PN4R7NR0	4.7 ±30%	100	1750	1400	0.060 ±20%	30
LQH55PN6R8NR0	6.8 ±30%	100	1450	1200	0.087 ±20%	25
LQH55PN100MR0	10 ±20%	100	1250	1000	0.11 ±20%	20
LQH55PN220MR0	22 ±20%	100	850	670	0.26 ±20%	10

Operating Temperature Range: -40°C to +85°C
Only for reflow soldering.

Chip Inductor (Chip Coil)

for DC-DC Converter Multilayer Type

● LQM21P Series (0805)

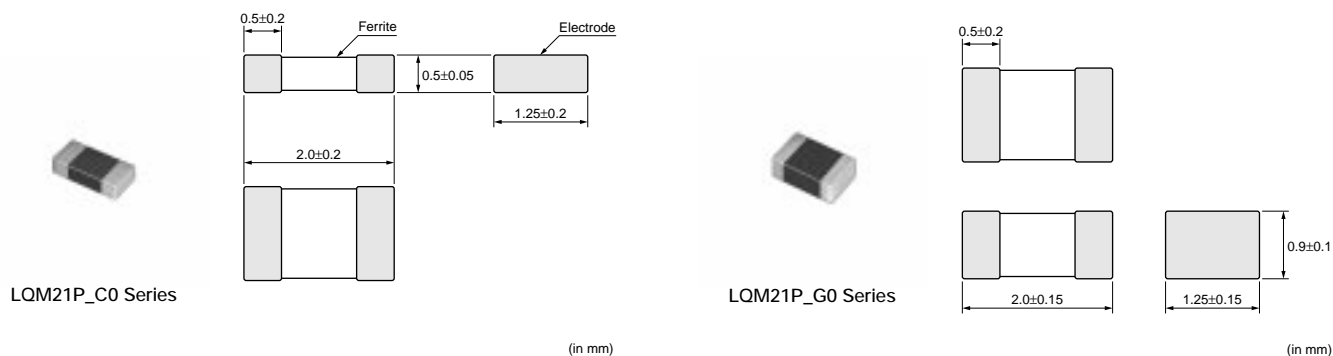

LQM21P_C0 Series (0805)

Part Number	Inductance (μH)	Test Frequency (MHz)	Rated Current (mA)	DC Resistance (ohm)	Self Resonance Frequency (min.) (MHz)
LQM21PNR47MC0	0.47 ±20%	1	1100	0.12 ±25%	100
LQM21PN1R0MC0	1.0 ±20%	1	800	0.19 ±25%	90
LQM21PN1R5MC0	1.5 ±20%	1	700	0.26 ±25%	70
LQM21PN2R2MC0	2.2 ±20%	1	600	0.34 ±25%	50

Operating Temperature Range: -55 to +125°C

LQM21P_G0 Series (0805)

Part Number	Inductance (μH)	Test Frequency (MHz)	Rated Current (mA)	DC Resistance (ohm)	Self Resonance Frequency (min.) (MHz)
LQM21PNR54MG0	0.54 ±20%	1	1300	0.075 ±25%	100

Operating Temperature Range: -55 to +125°C

● LQM2MP Series (0806)

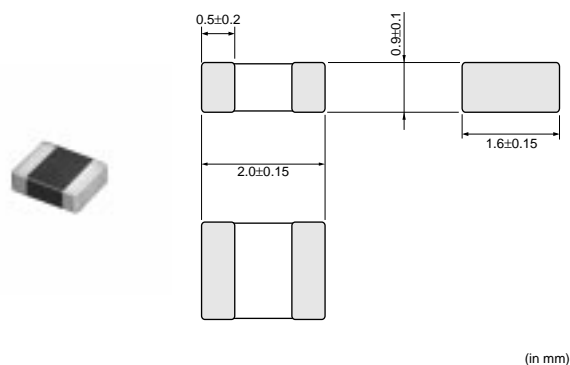

Part Number	Inductance (μH)	Test Frequency (MHz)	Rated Current (mA)	DC Resistance (ohm)	Self Resonance Frequency (min.) (MHz)
LQM2MPNR47NG0	0.47 ±30%	1	1600	0.06 ±25%	100
LQM2MPN1R0NG0	1.0 ±30%	1	1400	0.085 ±25%	60
LQM2MPN1R5NG0	1.5 ±30%	1	1200	0.11 ±25%	50
LQM2MPN2R2NG0	2.2 ±30%	1	1200	0.11 ±25%	40
LQM2MPN3R3NG0	3.3 ±30%	1	1200	0.12 ±25%	30
LQM2MPN4R7NG0	4.7 ±30%	1	1100	0.14 ±25%	20

Operating Temperature Range: -55 to +125°C

△Note • This PDF catalog is downloaded from the website of Murata Manufacturing co., ltd. Therefore, it's specifications are subject to change or our products in it may be discontinued without advance notice. Please check with our sales representatives or product engineers before ordering.
• This PDF catalog has only typical specifications because there is no space for detailed specifications. Therefore, please approve our product specifications or transact the approval sheet for product specifications before ordering.

● LQM2HP Series (1008)



LQM2HP_J0 Series

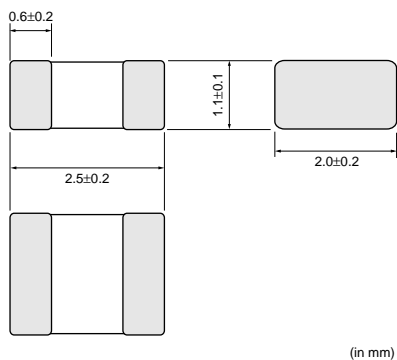

LQM2HP_G0 Series

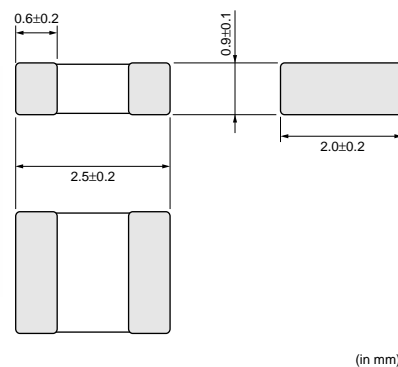

LQM2HP_E0 Series

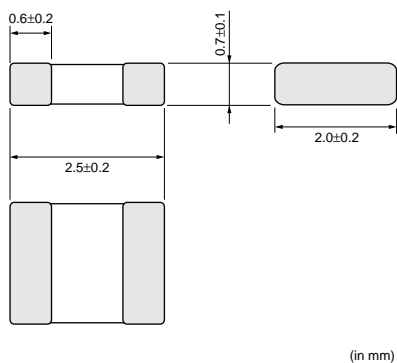

Part Number	Inductance (μH)	Test Frequency (MHz)	Rated Current (mA)	DC Resistance (ohm)	Self Resonance Frequency (min.) (MHz)
LQM2HPN1R0MJ0	1.0 ±20%	1	1500	0.09 ±25%	70
LQM2HPN2R2MJ0	2.2 ±20%	1	1000	0.12 ±25%	40
LQM2HPN3R3MJ0	3.3 ±20%	1	1000	0.12 ±25%	30
LQM2HPNR47MG0	0.47 ±20%	1	1800	0.04 ±25%	100
LQM2HPN1R0MG0	1.0 ±20%	1	1600	0.055 ±25%	60
LQM2HPN1R5MG0	1.5 ±20%	1	1500	0.07 ±25%	50
LQM2HPN2R2MG0	2.2 ±20%	1	1300	0.08 ±25%	40
LQM2HPN3R3MG0	3.3 ±20%	1	1200	0.10 ±25%	30
LQM2HPN4R7MG0	4.7 ±20%	1	1100	0.11 ±25%	25
LQM2HPNR56ME0	0.56 ±20%	1	1500	0.06 ±25%	70

Operating Temperature Range: -55 to +125°C

● LQM31P Series (1206)



LQM31P_00 Series

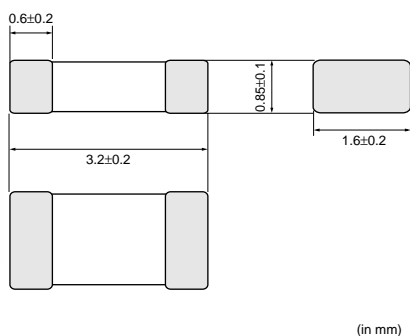

LQM31P_C0 Series

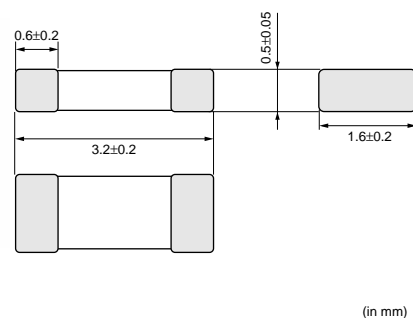

Part Number	Inductance (μH)	Test Frequency (MHz)	Rated Current (mA)	DC Resistance (ohm)	Self Resonance Frequency (min.) (MHz)
LQM31PNR47M00	0.47 ±20%	1	1400	0.07 ±25%	80
LQM31PN1R0M00	1.0 ±20%	1	1200	0.12 ±25%	60
LQM31PN1R5M00	1.5 ±20%	1	1000	0.14 ±25%	50
LQM31PN2R2M00	2.2 ±20%	1	900	0.19 ±25%	40
LQM31PN3R3M00	3.3 ±20%	1	800	0.24 ±25%	30
LQM31PN4R7M00	4.7 ±20%	1	700	0.30 ±25%	25
LQM31PNR47MC0	0.47 ±20%	1	1300	0.085 ±25%	90
LQM31PN1R0MC0	1.0 ±20%	1	1100	0.14 ±25%	70
LQM31PN1R5MC0	1.5 ±20%	1	1000	0.17 ±25%	60
LQM31PN2R2MC0	2.2 ±20%	1	900	0.25 ±25%	50

Operating Temperature Range: -55 to +125°C

Chip Inductor (Chip Coil)

for Choke Wire Wound Type

● LQH31C Series (1206)

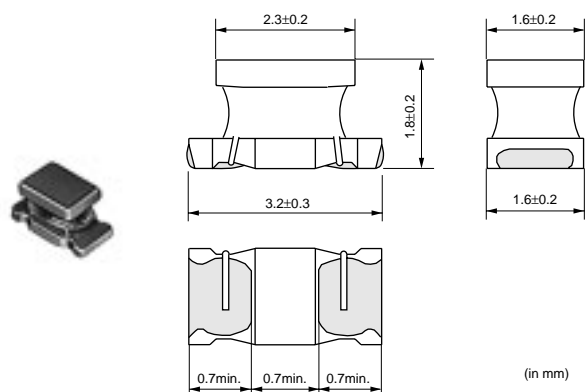

Part Number	Inductance (μH)	Test Frequency (MHz)	Rated Current (mA)	DC Resistance (ohm)	Self Resonance Frequency (min.) (MHz)
LQH31CNR12M03	0.12 ±20%	1	970	0.08 ±40%	250
LQH31CNR22M03	0.22 ±20%	1	850	0.1 ±40%	250
LQH31CNR47M03	0.47 ±20%	1	700	0.15 ±40%	180
LQH31CN1R0M03	1.0 ±20%	1	510	0.28 ±30%	100
LQH31CN2R2M03	2.2 ±20%	1	430	0.41 ±30%	50
LQH31CN4R7M03	4.7 ±20%	1	340	0.65 ±30%	31
LQH31CN100K03	10 ±10%	1	230	1.3 ±30%	20
LQH31CN220K03	22 ±10%	1	160	3.0 ±30%	14
LQH31CN470K03	47 ±10%	1	100	8.0 ±30%	10
LQH31CN101K03	100 ±10%	1	80	12 ±30%	7

Operating Temperature Range: -40 to +85°C

● LQH32C Series (1210)

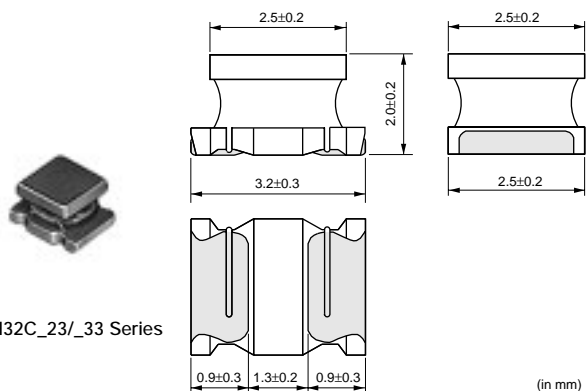

LQH32C_23/_33 Series

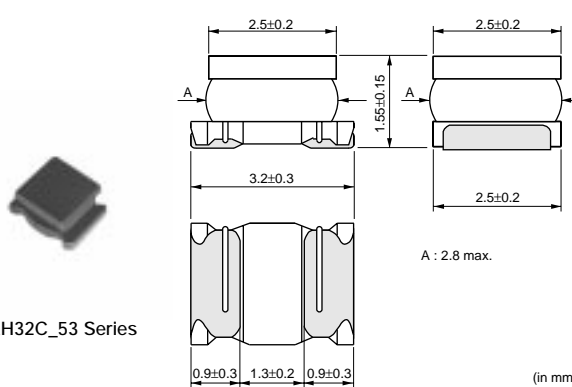

LQH32C_53 Series

(in mm)

(in mm)

Part Number	Inductance (μH)	Test Frequency	Rated Current (mA)	DC Resistance (ohm)	Self Resonance Frequency (min.) (MHz)
LQH32CN1R0M23	1.0 ±20%	1MHz	800	0.09 ±30%	96
LQH32CN2R2M23	2.2 ±20%	1MHz	600	0.13 ±30%	64
LQH32CN4R7M23	4.7 ±20%	1MHz	450	0.2 ±30%	43
LQH32CN100K23	10 ±10%	1MHz	300	0.44 ±30%	26
LQH32CN220K23	22 ±10%	1MHz	250	0.71 ±30%	19
LQH32CN470K23	47 ±10%	1MHz	170	1.3 ±30%	15
LQH32CN101K23	100 ±10%	1MHz	100	3.5 ±30%	10
LQH32CN221K23	220 ±10%	1MHz	70	8.4 ±30%	6.8
LQH32CN331K23	330 ±10%	1MHz	60	10 ±30%	5.6
LQH32CN391K23	390 ±10%	1MHz	60	17 ±30%	5
LQH32CN471K23	470 ±10%	1kHz	60	19 ±30%	5
LQH32CN561K23	560 ±10%	1kHz	60	22 ±30%	5
LQH32CNR15M33	0.15 ±20%	1MHz	1450	0.028 ±30%	400
LQH32CNR27M33	0.27 ±20%	1MHz	1250	0.034 ±30%	250
LQH32CNR47M33	0.47 ±20%	1MHz	1100	0.042 ±30%	150
LQH32CN1R0M33	1.0 ±20%	1MHz	1000	0.06 ±30%	100
LQH32CN2R2M33	2.2 ±20%	1MHz	790	0.097 ±30%	64
LQH32CN4R7M33	4.7 ±20%	1MHz	650	0.15 ±30%	43
LQH32CN100K33	10 ±10%	1MHz	450	0.3 ±30%	26
LQH32CN1R0M53	1.0 ±20%	1MHz	1000	0.060 ±30%	100
LQH32CN2R2M53	2.2 ±20%	1MHz	790	0.097 ±30%	64
LQH32CN3R3M53	3.3 ±20%	1MHz	710	0.12 ±30%	50
LQH32CN4R7M53	4.7 ±20%	1MHz	650	0.15 ±30%	43
LQH32CN6R8M53	6.8 ±20%	1MHz	540	0.25 ±30%	32
LQH32CN100K53	10 ±10%	1MHz	450	0.30 ±30%	26
LQH32CN150K53	15 ±10%	1MHz	300	0.58 ±30%	26
LQH32CN220K53	22 ±10%	1MHz	250	0.71 ±30%	19
LQH32CN330K53	33 ±10%	1MHz	200	1.1 ±30%	17
LQH32CN470K53	47 ±10%	1MHz	170	1.3 ±30%	15
LQH32CN680K53	68 ±10%	1MHz	130	2.2 ±30%	12
LQH32CN101K53	100 ±10%	1MHz	100	3.5 ±30%	10

Operating Temperature Range: -40 to +85°C

● LQH43C Series (1812)

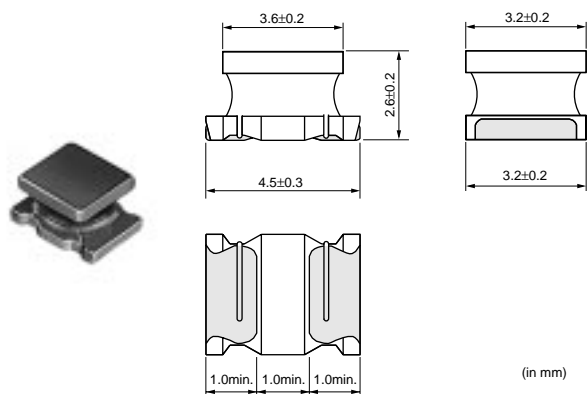

Part Number	Inductance (μH)	Test Frequency	Rated Current (mA)	DC Resistance (ohm)	Self Resonance Frequency (min.) (MHz)
LQH43CN1R0M03	1.0 ±20%	1MHz	1080	0.08 max.	100
LQH43CN1R5M03	1.5 ±20%	1MHz	1000	0.09 max.	85
LQH43CN2R2M03	2.2 ±20%	1MHz	900	0.11 max.	60
LQH43CN3R3M03	3.3 ±20%	1MHz	800	0.13 max.	47
LQH43CN4R7M03	4.7 ±20%	1MHz	750	0.15 max.	35
LQH43CN6R8M03	6.8 ±20%	1MHz	720	0.20 max.	30
LQH43CN100K03	10 ±10%	1MHz	650	0.24 max.	23
LQH43CN150K03	15 ±10%	1MHz	570	0.32 max.	20
LQH43CN220K03	22 ±10%	1MHz	420	0.6 max.	15
LQH43CN330K03	33 ±10%	1MHz	310	1.0 max.	12
LQH43CN470K03	47 ±10%	1MHz	280	1.1 max.	10
LQH43CN680K03	68 ±10%	1MHz	220	1.7 max.	8.4
LQH43CN101K03	100 ±10%	1MHz	190	2.2 max.	6.8
LQH43CN151K03	150 ±10%	1MHz	130	3.5 max.	5.5
LQH43CN221K03	220 ±10%	1MHz	110	4.0 max.	4.5
LQH43CN331K03	330 ±10%	1MHz	100	6.8 max.	3.6
LQH43CN471K03	470 ±10%	1kHz	90	8.5 max.	3.0

Operating Temperature Range: -40 to +85°C

Chip Inductor (Chip Coil)

for Choke Multilayer Type

● LQM18F Series (0603)

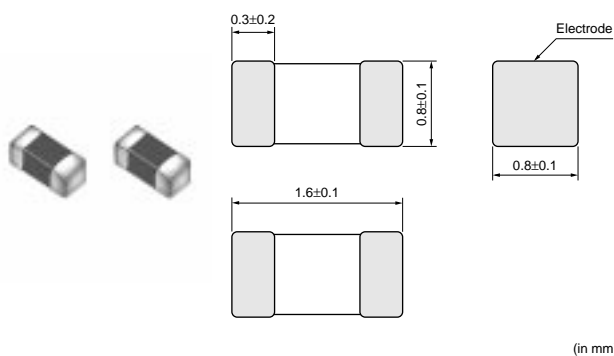

△Note • This PDF catalog is downloaded from the website of Murata Manufacturing co., ltd. Therefore, it's specifications are subject to change or our products in it may be discontinued without advance notice. Please check with our sales representatives or product engineers before ordering.
• This PDF catalog has only typical specifications because there is no space for detailed specifications. Therefore, please approve our product specifications or transact the approval sheet for product specifications before ordering.

Part Number	Inductance (μH)	Test Frequency (MHz)	Rated Current (mA)	DC Resistance (ohm)	Self Resonance Frequency (min.) (MHz)
LQM18FN1R0M00	1.0 ±20%	1	150	0.20 ±30%	120
LQM18FN2R2M00	2.2 ±20%	1	120	0.40 ±30%	80
LQM18FN4R7M00	4.7 ±20%	1	80	0.60 ±30%	50
LQM18FN100M00	10 ±20%	1	50	0.90 ±30%	30

Operating Temperature Range: -55 to +125°C

3

Inductors (Coils)

● LQM21D/F Series (0805)

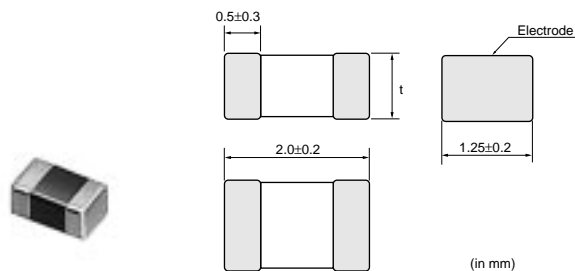

LQM21D Series

Dimension of t	Inductance: 1.0 to 10μH	0.85±0.2
		Inductance: 22 to 47μH

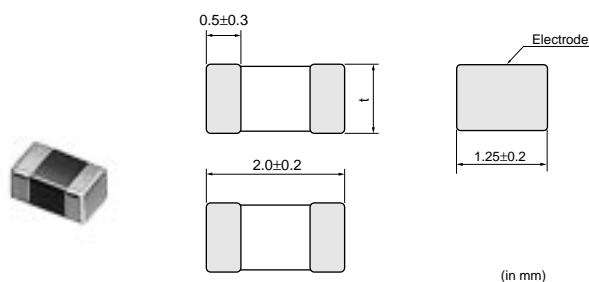

LQM21F_00 Series

Dimension of t	Inductance: 1.0 to 2.2μH	0.85±0.2
		Inductance: 4.7 to 47μH

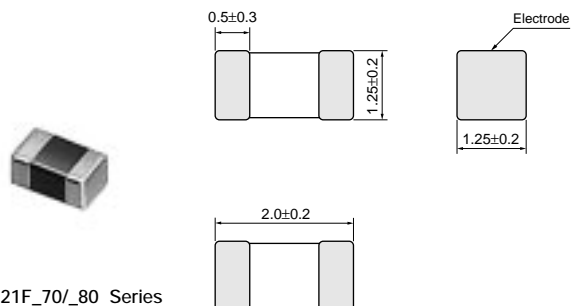

LQM21F_70/_80 Series

(in mm)

Part Number	Inductance (μH)	Test Frequency (MHz)	Rated Current (mA)	DC Resistance (ohm)	Self Resonance Frequency (min.) (MHz)
LQM21DN1R0N00	1.0 ±30%	1	60	0.10 max.	75
LQM21DN2R2N00	2.2 ±30%	1	40	0.17 max.	50
LQM21DN4R7N00	4.7 ±30%	1	30	0.30 max.	35
LQM21DN100N00	10 ±30%	1	15	0.50 max.	24
LQM21DN220N00	22 ±30%	1	13	0.65 max.	16
LQM21DN470N00	47 ±30%	1	7	1.20 max.	7.5
LQM21FN1R0N00	1.0 ±30%	1	220	0.20 ±30%	105
LQM21FN2R2N00	2.2 ±30%	1	150	0.28 ±30%	70
LQM21FN4R7N00	4.7 ±30%	1	80	0.30 ±30%	25
LQM21FN100N00	10 ±30%	1	60	0.50 ±30%	15
LQM21FN220N00	22 ±30%	1	13	0.35 ±30%	15
LQM21FN470N00	47 ±30%	1	7	0.60 ±30%	7.5
LQM21FN4R7M70	4.7 ±20%	1	120	0.35 ±30%	25
LQM21FN100M70	10 ±20%	1	100	0.60 ±30%	15
LQM21FN4R7M80	4.7 ±20%	1	120	0.18 ±30%	25
LQM21FN100M80	10 ±20%	1	100	0.30 ±30%	15

Operating Temperature Range: -40°C to +85°C (LQM21D/21F_00 Series), -55°C to +125°C (LQM21F_70/_80 Series)

● LQM31F Series (1206)

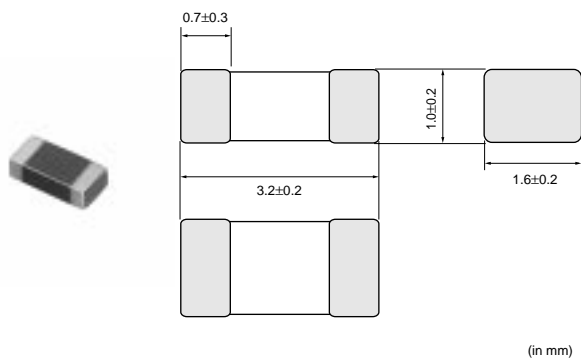

Part Number	Inductance (μH)	Test Frequency (MHz)	Rated Current (mA)	DC Resistance (ohm)	Self Resonance Frequency (min.) (MHz)
LQM31FN100M00	10 ±20%	1	70	0.50 max.	20

Operating Temperature Range: -40 to +85°C

Chip Inductor (Chip Coil)

for Choke Large Current Type

● LQH55D Series (2220)

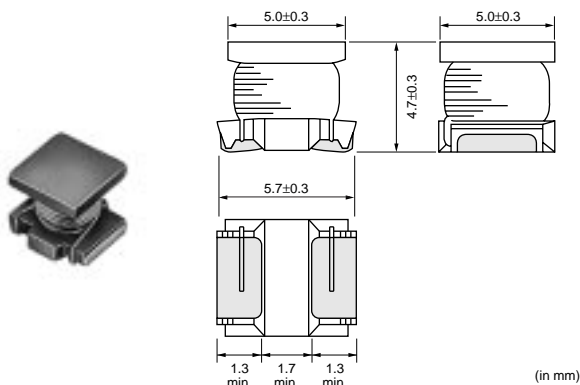

Part Number	Inductance (μH)	Test Frequency	Rated Current (mA)	DC Resistance (ohm)	Self Resonance Frequency (min.) (MHz)
LQH55DNR12M03	0.12 ±20%	1MHz	6000	0.007 ±40%	450
LQH55DNR27M03	0.27 ±20%	1MHz	5300	0.010 ±40%	300
LQH55DNR47M03	0.47 ±20%	1MHz	4800	0.013 ±40%	200
LQH55DN1R0M03	1.0 ±20%	1MHz	4000	0.019 ±40%	150
LQH55DN1R5M03	1.5 ±20%	1MHz	3700	0.022 ±40%	110
LQH55DN2R2M03	2.2 ±20%	1MHz	3200	0.029 ±40%	80
LQH55DN3R3M03	3.3 ±20%	1MHz	2900	0.036 ±40%	40
LQH55DN4R7M03	4.7 ±20%	1MHz	2700	0.041 ±40%	30
LQH55DN6R8M03	6.8 ±20%	1MHz	2000	0.074 ±40%	25
LQH55DN100M03	10 ±20%	1MHz	1700	0.093 ±40%	20
LQH55DN150M03	15 ±20%	1MHz	1400	0.15 ±40%	17
LQH55DN220M03	22 ±20%	1MHz	1200	0.19 ±40%	15
LQH55DN330M03	33 ±20%	1MHz	900	0.32 ±40%	12
LQH55DN470M03	47 ±20%	1MHz	800	0.40 ±40%	10
LQH55DN680M03	68 ±20%	1MHz	640	0.67 ±40%	7.6
LQH55DN101M03	100 ±20%	100kHz	560	0.86 ±40%	6.5
LQH55DN151M03	150 ±20%	100kHz	420	1.9 ±40%	5.0
LQH55DN221M03	220 ±20%	100kHz	320	2.4 ±40%	4.0

Continued on the following page.

△Note • This PDF catalog is downloaded from the website of Murata Manufacturing co., ltd. Therefore, it's specifications are subject to change or our products in it may be discontinued without advance notice. Please check with our sales representatives or product engineers before ordering.
• This PDF catalog has only typical specifications because there is no space for detailed specifications. Therefore, please approve our product specifications or transact the approval sheet for product specifications before ordering.

Continued from the preceding page.

Part Number	Inductance (μH)	Test Frequency	Rated Current (mA)	DC Resistance (ohm)	Self Resonance Frequency (min.) (MHz)
LQH55DN331M03	330 ±20%	100kHz	270	4.4 ±40%	3.1
LQH55DN471M03	470 ±20%	100kHz	240	5.4 ±40%	2.4
LQH55DN681M03	680 ±20%	100kHz	190	8.1 ±40%	1.9
LQH55DN102M03	1000 ±20%	10kHz	150	10.3 ±40%	1.7
LQH55DN222M03	2200 ±20%	10kHz	100	21.5 ±40%	1.2
LQH55DN472M03	4700 ±20%	10kHz	70	43.6 ±40%	0.8
LQH55DN103M03	10000 ±20%	10kHz	50	100 ±40%	0.5

Operating Temperature Range: -40 to +80°C
Only for reflow soldering.

● LQH66S Series (2525)

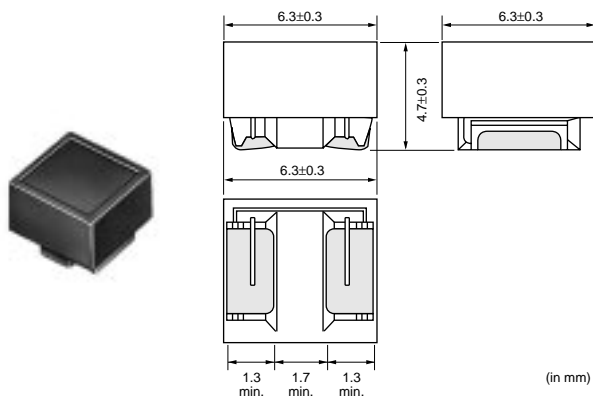

Part Number	Inductance (μH)	Test Frequency	Rated Current (mA)	DC Resistance (ohm)	Self Resonance Frequency (min.) (MHz)
LQH66SNR27M03	0.27 ±20%	1MHz	6000	0.007 ±40%	300
LQH66SNR68M03	0.68 ±20%	1MHz	5300	0.010 ±40%	180
LQH66SN1R0M03	1.0 ±20%	1MHz	4700	0.013 ±40%	150
LQH66SN1R5M03	1.5 ±20%	1MHz	3800	0.016 ±40%	110
LQH66SN2R2M03	2.2 ±20%	1MHz	3300	0.019 ±40%	80
LQH66SN3R3M03	3.3 ±20%	1MHz	2600	0.022 ±40%	40
LQH66SN4R7M03	4.7 ±20%	1MHz	2200	0.025 ±40%	30
LQH66SN6R8M03	6.8 ±20%	1MHz	1800	0.029 ±40%	25
LQH66SN100M03	10 ±20%	1MHz	1600	0.036 ±40%	20
LQH66SN150M03	15 ±20%	1MHz	1300	0.069 ±40%	17
LQH66SN220M03	22 ±20%	1MHz	1100	0.087 ±40%	15
LQH66SN330M03	33 ±20%	1MHz	860	0.14 ±40%	12
LQH66SN470M03	47 ±20%	1MHz	760	0.17 ±40%	10
LQH66SN680M03	68 ±20%	1MHz	600	0.29 ±40%	7.6
LQH66SN101M03	100 ±20%	100kHz	520	0.36 ±40%	6.5
LQH66SN151M03	150 ±20%	100kHz	420	0.63 ±40%	5.0
LQH66SN221M03	220 ±20%	100kHz	350	0.79 ±40%	4.0
LQH66SN331M03	330 ±20%	100kHz	280	1.8 ±40%	3.2
LQH66SN471M03	470 ±20%	100kHz	240	2.2 ±40%	2.5
LQH66SN681M03	680 ±20%	100kHz	200	3.9 ±40%	2.0
LQH66SN102M03	1000 ±20%	10kHz	160	4.9 ±40%	1.7
LQH66SN222M03	2200 ±20%	10kHz	100	9.4 ±40%	1.2
LQH66SN472M03	4700 ±20%	10kHz	70	19.5 ±40%	0.8
LQH66SN103M03	10000 ±20%	10kHz	50	39.7 ±40%	0.5

Operating Temperature Range: -40 to +85°C
Only for reflow soldering.

Balun

Film Type

● DXP18BN Series

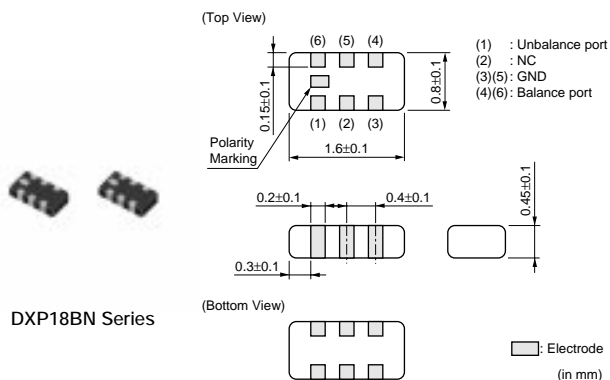

Equivalent Circuit

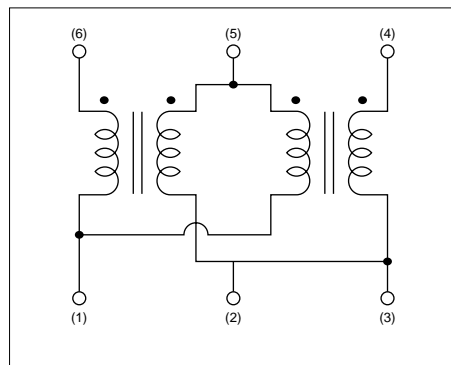

Part Number	Min. Frequency Range (MHz)	Max. Frequency Range (MHz)	Port Impedance	Insertion Loss at Freq. Range (max.) (dB)	CMRR at Freq. Range (min.) (dB)	Rated Power (dBm)
DXP18BN5014H	470	790	50/200	1.2	25	20
DXP18BN5014T	50	870	50/200	1.5	25	20
DXP18BN7514T	50	870	75/300	1.5	25	20

Operating Temperature Range: -40°C to +85°C
Only for reflow soldering.

Balun

Wire Wound Type

● DXW21BN Series

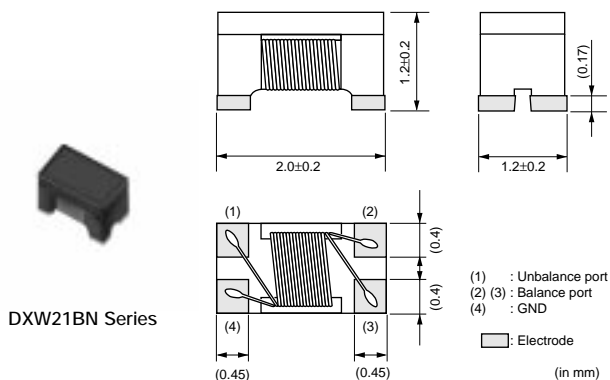

Equivalent Circuit

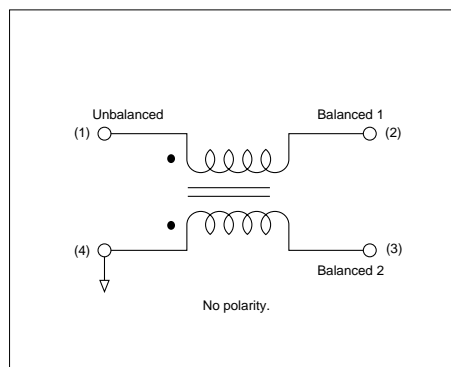

Part Number	Min. Frequency Range	Max. Frequency Range	Port Impedance	Insertion Loss at Freq. Range (max.) (dB)	CMRR at Freq. Range (min.) (dB)	Rated Power (dBm)
DXW21BN7511S	1GHz	1.5GHz	75/75	1.4	20	27
DXW21BN7511T	50MHz	870MHz	75/75	1.0	20	27

Operating Temperature Range: -40°C to +85°C
Only for reflow soldering.

△Note • This PDF catalog is downloaded from the website of Murata Manufacturing co., ltd. Therefore, it's specifications are subject to change or our products in it may be discontinued without advance notice. Please check with our sales representatives or product engineers before ordering.
• This PDF catalog has only typical specifications because there is no space for detailed specifications. Therefore, please approve our product specifications or transact the approval sheet for product specifications before ordering.

Coupler

Film Type

● **DXP18C Series**

Equivalent Circuit

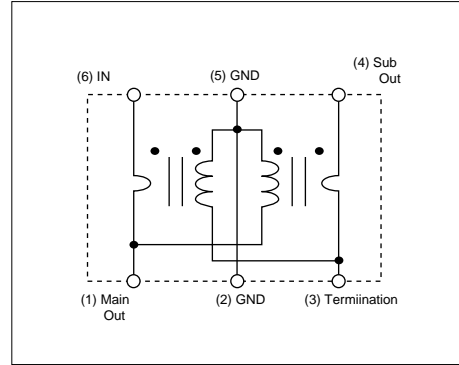
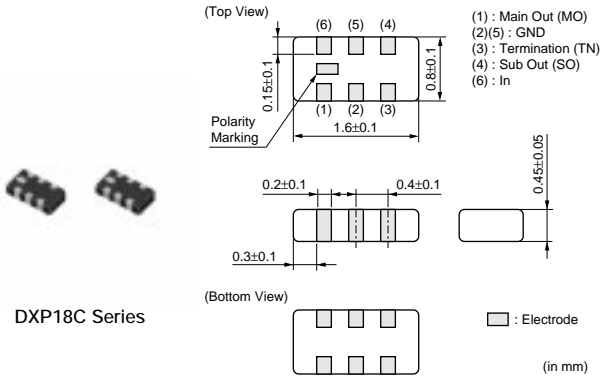

3
Inductors (Coils)

Part Number	Min. Frequency Range (MHz)	Max. Frequency Range (MHz)	Port Impedance	Insertion Loss at Freq. Range (max.) (dB)	Coupling Loss at Freq. Range (Typ.) (dB)	Isolation at Freq. Range (Min) (dB)	Rated Power (dBm)
DXP18CN7510T	50	870	75 ohm ALL	2.3	10	18	20
DXP18CN7515T	50	870	75 ohm ALL	1.5	15	20	20

Operating Temperature Range: -40°C to +85°C
Only for reflow soldering.

⚠️Note • This PDF catalog is downloaded from the website of Murata Manufacturing co., ltd. Therefore, it's specifications are subject to change or our products in it may be discontinued without advance notice. Please check with our sales representatives or product engineers before ordering.
• This PDF catalog has only typical specifications because there is no space for detailed specifications. Therefore, please approve our product specifications or transact the approval sheet for product specifications before ordering.

4

Resistors

High Voltage Resistors

R Networks

Trimmer Potentiometers

High Voltage Resistors

(Part Number) **MHR** **0409** **S** **A** **107** **J** **60**
 ① ② ③ ④ ⑤ ⑥ ⑦

- ① Product ID
- ② Board (W×L) Dimensions
- ③ Type
- ④ Circuit
- ⑤ Resistance

Expressed by three figures. The unit is ohm (Ω). The first and second figures are significant digits, and the third figure expresses the number of zeros which follow the two figures.

Ex.)

Code	Resistance
406	40MΩ
207	200MΩ

- ⑥ Resistance Tolerance
- ⑦ Individual Specifications

R Network

(Part Number)
 X, Y, L Circuit **RG** **LD** **8** **X** **103** **J** **T2**
 ① ② ③ ④ ⑤ ⑥ ⑨

Z, M Circuit **RG** **LD** **8** **M** **103** **J** **104** **J** **T2**
 ① ② ③ ④ ⑤ ⑥ ⑦ ⑧ ⑨

Custom Circuit **RG** **LD** **8** **A** ****
 ① ② ③ ④ ⑩

- ① Product ID
- ② Structure
- ③ Number of Element
- ④ Circuit
- ⑤ Nominal Resistance (Z, M Circuit : R_A
L Circuit : Output Impedance)

Expressed by three figures. The unit is ohm (Ω). The first and second figures are significant digits, and the third figure expresses the number of zeros which follow the two figures.

Ex.)

Code	Nominal Resistance
150	15Ω
103	10kΩ

- ⑥ Resistance Tolerance (Z, M Circuit : R_A
L Circuit : Impedance Tolerance)

- ⑦ Nominal Resistance (Z, M Circuit : R_B)

Expressed by three figures. The unit is ohm (Ω). The first and second figures are significant digits, and the third figure expresses the number of zeros which follow the two figures.

Ex.)

Code	Nominal Resistance
150	15Ω
104	100kΩ

If R_A and R_B values are the same, ⑦ and ⑧ remain blanks, and the corresponding code is omitted.



- ⑧ Resistance Tolerance (Z, M Circuit : R_B)
- ⑨ Packaging
- ⑩ Design No.

Trimmer Potentiometers

(Part Number) **PV** **A2** **A** **103** **A01** **R00**
 ① ② ③ ④ ⑤ ⑥

- ① Product ID
- ② Series

Code	Series
Z2	SMD Open 2mm Size Carbon Resistive Element
A2	SMD Open 2mm Size
Z3	SMD Open 3mm Size Carbon Resistive Element
F2	SMD Sealed 2mm Size
G3	SMD Sealed 3mm Size
M4	SMD Sealed 4mm Size
G5	SMD Sealed 5mm Square 11-turns
32	Lead Sealed 6mm Round Single-turn
12	Lead Sealed 7mm Round 4-turns
36	Lead Sealed 10mm Square 25-turns
37	Lead Sealed 6mm Square 12-turns

- ③ Adjustment Direction /Lead Type
- ④ Total Resistance

Expressed by three figures. The unit is ohm (Ω). The first and second figures are significant digits, and the third figure expresses the number of zeros which follow the two figures.

Ex.)

Code	Total Resistance
100	10Ω
102	1000Ω
104	100000Ω (=100kΩ)

- ⑤ Individual Specification

Series	Code	Individual Specification
PVA2	A01	Standard Type
PVZ2	C04	Standard, High-heat Resistance Type (for Ultra-thin Type)
PVZ3	C01	Standard, High-heat Resistance Type (for Top Adjustment)
	E01	Standard, High-heat Resistance Type (for Rear Adjustment)
PVM4	C01	Standard Type
	D01	High-liability Type
PVF2	A11	Standard Type (Resistance Change Characteristics: Linear)
PV32/PV12	A01	Standard Type
PVG3	C01	Standard Type
PV36/PV37	C01	Standard Type
	C31	Radial Taping
PVG5	C03	Standard Type

- ⑥ Packaging

High Voltage Resistors

● MHR_SA Series

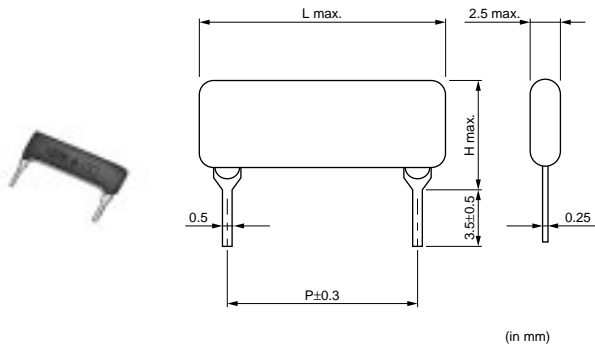

Part Number	Resistance (min.) (M ohm)	Resistance (max.) (M ohm)	Rated Voltage (Single Use) (kV)	Rated Voltage (Molded Use) (kV)	Rated Power (W)	Lead Pitch P (mm)	Length L (mm)	Height H (mm)
MHR0307SA○○○△□□	1	500	2	3	0.3	5.08	7.6	5.0
MHR0309SA○○○△□□	1	500	3.5	5	0.5	7.62	10.1	5.0
MHR0312SA○○○△□□	1	600	5	7	0.6	10.16	12.6	5.0
MHR0314SA○○○△□□	1	1000	6	10	0.7	12.70	15.1	5.0
MHR0317SA○○○△□□	1	1000	7	12	0.8	15.24	17.6	5.0
MHR0319SA○○○△□□	1	1000	8	14	1.0	17.78	20.2	5.0
MHR0409SA○○○△□□	1	1000	3.5	10	0.6	7.62	10.1	6.5
MHR0412SA○○○△□□	1	1000	5	10	0.8	10.16	12.6	6.5
MHR0414SA○○○△□□	1	1000	6	10	1.0	12.70	15.1	6.5
MHR0417SA○○○△□□	1	1000	7	12	1.1	15.24	17.6	6.5
MHR0419SA○○○△□□	1	1000	8	14	1.2	17.78	20.2	6.5
MHR0422SA○○○△□□	1	1000	9	16	1.3	20.32	22.7	6.5
MHR0609SA○○○△□□	1	1000	3.5	10	0.8	7.62	10.1	9.0
MHR0612SA○○○△□□	1	1000	5	10	1.0	10.16	12.6	9.0
MHR0614SA○○○△□□	1	1000	6	12	1.2	12.70	15.1	9.0
MHR0617SA○○○△□□	1	1000	7	14	1.3	15.24	17.6	9.0
MHR0619SA○○○△□□	1	1000	8	16	1.4	17.78	20.2	9.0
MHR0622SA○○○△□□	1	1000	9	18	1.5	20.32	22.7	9.0

For resistance value and ratio of B circuit, please contact us.

R Networks

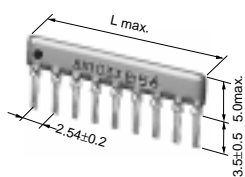

Standard Profile RGLD Series

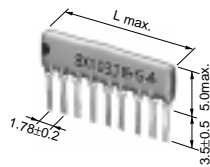

Shrink Profile RGLE Series

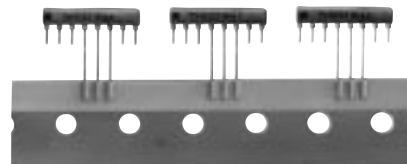

RGLD Series Taping Type (4-9 pin)

in mm

△Note • This PDF catalog is downloaded from the website of Murata Manufacturing co., ltd. Therefore, it's specifications are subject to change or our products in it may be discontinued without advance notice. Please check with our sales representatives or product engineers before ordering.
• This PDF catalog has only typical specifications because there is no space for detailed specifications. Therefore, please approve our product specifications or transact the approval sheet for product specifications before ordering.

● Standard Circuits

Type	X Type	Y Type	Z Type	M Type	
Circuit (n: Number of resistors)					
Number of Resistor	RGLD RGLE	3 to 12 3 to 15	3 to 7 3 to 8	8 to 18 —	6 to 12 6 to 12

● Rating

	RGLD Series	RGLE Series
Rated Power (W)	1/8	1/10
Package Power (W)	Rated Power X Number of Resistors X K (K: coefficient)	
Resistance Range (Ω)	10 to 1M (X, Y, M Type)	
Resistance Value	E-12 Value (X, Y, M Type)	
Resistance Tolerance (%)	J ; ±5, G ; ±2 (22Ω min.)	
T.C.R (ppm/°C)	±200	
Max Operating Voltage (V)	100	
Operating Temperature (°C)	-55 to +125	
Derating Curve		E-12 Values 10, 12, 15, 18, 22, 27, 33, 39, 47, 56, 68, 82 Standard Resistance Value for Z type (Ω) R1/R2=180/390, 220/330, 330/390, 330/470

● L Dimensions

Series \ Number of Pins	4	5	6	7	8	9	10	11	12	13	14	15	16
RGLE (pitch 1.78)	7.7	9.5	11.2	12.9	14.6	16.4	18.2	20.0	21.8	23.5	25.3	27.1	28.9
RGLD (pitch 2.54)	10.1	12.6	15.1	17.6	20.2	22.7	25.3	27.8	30.5	33.0	35.5	-	-

in mm

Custom-made circuits are also available. Please contact us.

Minimum Quantity (order in sets only) : 1,000 pcs. (Bulk/Taping)

Trimmer Potentiometers

SMD Open Type 2mm Size

● PVZ2 Series

PVZ2A Series

*1 Driver Plate Rotation Area:
Please do not place any components more than 0.5mm in height within this area.
(Tolerance: ±0.2 in mm)

PVZ2R Series

*1 Driver Plate Rotation Area
(Tolerance: ±0.2 in mm)

Part Number	Power Rating (W)	Soldering Method	Number of Turns (Effective Rotation Angle)	Total Resistance Value	TCR (ppm/°C)
PVZ2A_C04	0.05(50°C)	Reflow/Soldering Iron	1(240°±10°)	470ohm to 1M ohm ±30%	±500
PVZ2R_C04	0.1(50°C)	Reflow/Soldering Iron	1(240°±10°)	470ohm to 1M ohm ±30%	±500

Operating Temperature: -25 to +85°C

The order quantity should be an integral multiple of the "Minimum Quantity" shown in the beginning of this catalog.

● PVA2 Series

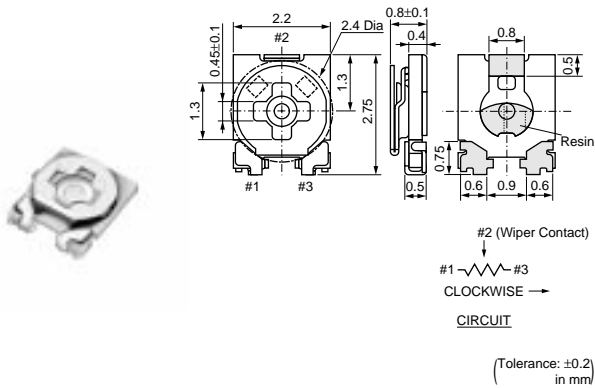

Part Number	Power Rating (W)	Soldering Method	Number of Turns (Effective Rotation Angle)	Total Resistance Value	TCR (ppm/°C)
PVA2A	0.1(70°C)	Reflow/Soldering Iron	1(260°±10°)	100ohm to 2.2M ohm ±25%	±250

Operating Temperature: -55 to +125°C

The order quantity should be an integral multiple of the "Minimum Quantity" shown in the beginning of this catalog.

Trimmer Potentiometers

SMD Open Type 3mm Size

● PVZ3 Series

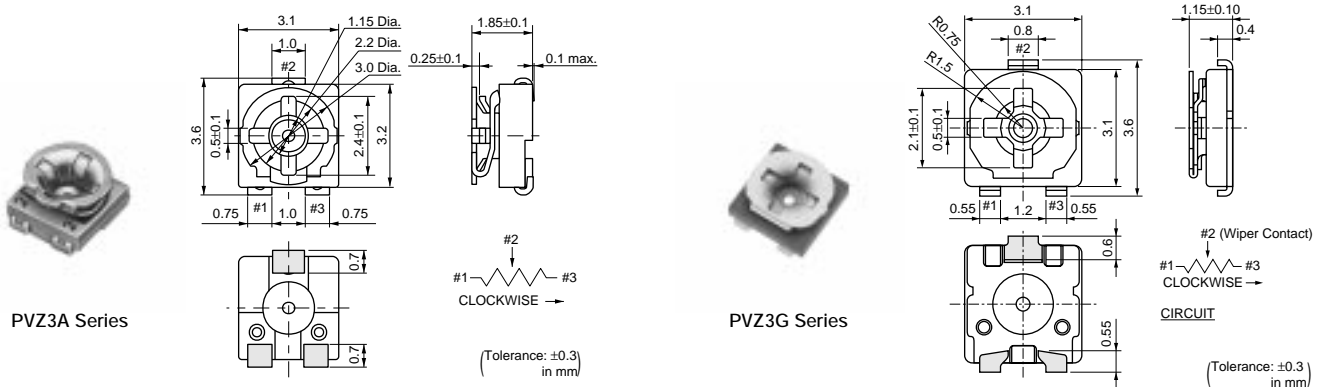

Continued on the following page.

Continued from the preceding page.



PVZ3K Series

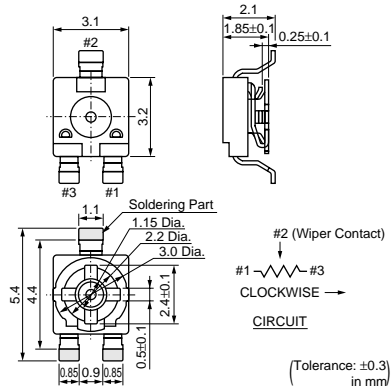

Part Number	Power Rating (W)	Soldering Method	Number of Turns (Effective Rotation Angle)	Total Resistance Value	TCR (ppm/°C)
PVZ3A_C01	0.1(50°C)	Reflow/Soldering Iron	1(230°±10°)	220ohm to 2.2M ohm ±30%	±500
PVZ3G_C01	0.1(50°C)	Reflow/Soldering Iron	1(230°±10°)	220ohm to 2.2M ohm ±30%	±500
PVZ3K_E01	0.1(50°C)	Reflow/Soldering Iron	1(230°±10°)	220ohm to 2.2M ohm ±30%	±500

Operating Temperature: -25 to +85°C

The order quantity should be an integral multiple of the "Minimum Quantity" shown in the beginning of this catalog.

Trimmer Potentiometers

SMD Sealed Type 2mm Size

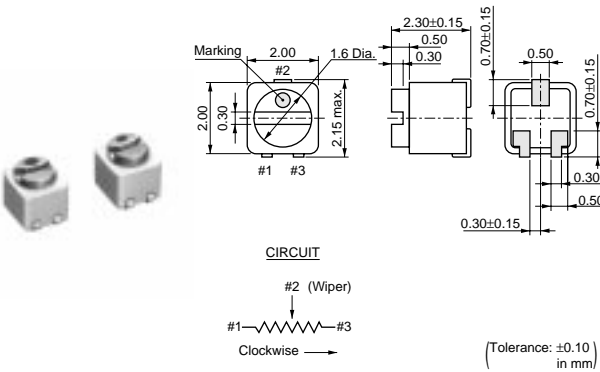

Part Number	Power Rating (W)	Soldering Method	Number of Turns (Effective Rotation Angle)	Total Resistance Value	TCR (ppm/°C)
PVF2A	0.001(50°C)	Reflow/Soldering Iron	1(210°±10°)	500ohm to 1M ohm ±30%	±500

Operating Temperature: -25 to +60°C

The order quantity should be an integral multiple of the "Minimum Quantity" shown in the beginning of this catalog.

Trimmer Potentiometers

SMD Sealed Type 3mm Size



PVG3A Series

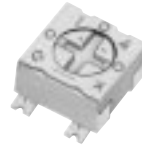
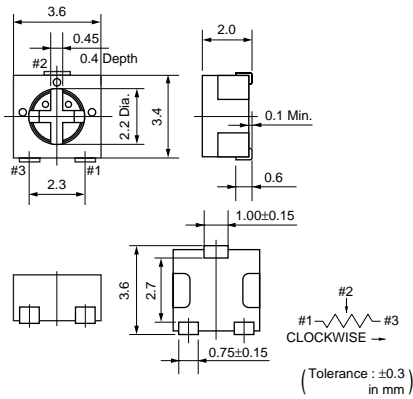

PVG3G Series

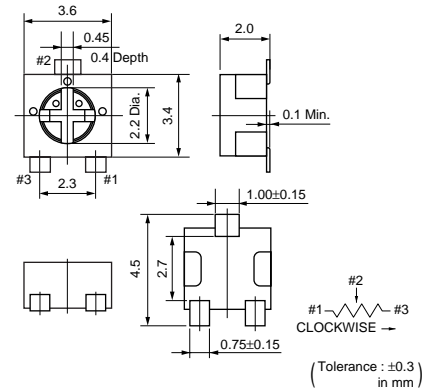

PVG3K Series

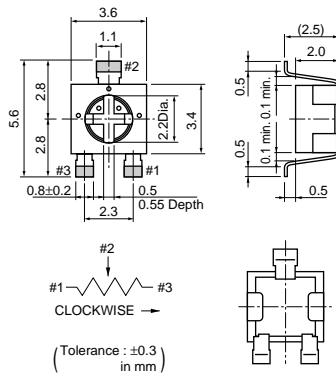

Part Number	Power Rating (W)	Soldering Method	Number of Turns (Effective Rotation Angle)	Total Resistance Value	TCR (ppm/°C)
PVG3A	0.25(70°C)	Reflow/Soldering Iron	1(210°±10°)	10ohm to 2M ohm ±20%	±150
PVG3G	0.25(70°C)	Reflow/Soldering Iron	1(210°±10°)	10ohm to 2M ohm ±20%	±150
PVG3K	0.25(70°C)	Reflow/Soldering Iron	1(210°±10°)	10ohm to 2M ohm ±20%	±150

Operating Temperature: -55 to +125°C

The order quantity should be an integral multiple of the "Minimum Quantity" shown in the beginning of this catalog.

Trimmer Potentiometers

SMD Sealed Type 4mm Size

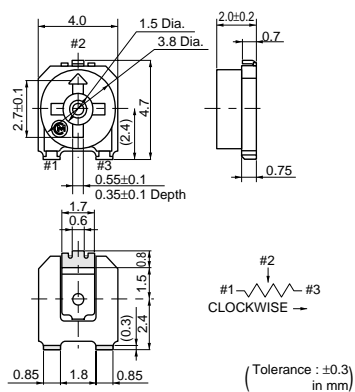

△Note • This PDF catalog is downloaded from the website of Murata Manufacturing co., ltd. Therefore, it's specifications are subject to change or our products in it may be discontinued without advance notice. Please check with our sales representatives or product engineers before ordering.
• This PDF catalog has only typical specifications because there is no space for detailed specifications. Therefore, please approve our product specifications or transact the approval sheet for product specifications before ordering.

Part Number	Power Rating (W)	Soldering Method	Number of Turns (Effective Rotation Angle)	Total Resistance Value	TCR (ppm/°C)
PVM4A□□□C01	0.1(70°C)	Flow/Reflow/Soldering Iron	1(240°±10°)	100ohm to 2M ohm ±25%	±250
PVM4A□□□D01	0.25(70°C)	Flow/Reflow/Soldering Iron	1(240°±10°)	100ohm to 500ohm ±20%	±100
	0.25(70°C)	Flow/Reflow/Soldering Iron	1(240°±10°)	1k ohm to 5k ohm ±20%	±200
	0.25(70°C)	Flow/Reflow/Soldering Iron	1(240°±10°)	10k ohm to 2M ohm ±20%	±150

Operating Temperature: -55 to +125°C

The order quantity should be an integral multiple of the "Minimum Quantity" shown in the beginning of this catalog.

Trimmer Potentiometers

SMD Sealed Type Multi-turns

● **PVG5 Series**

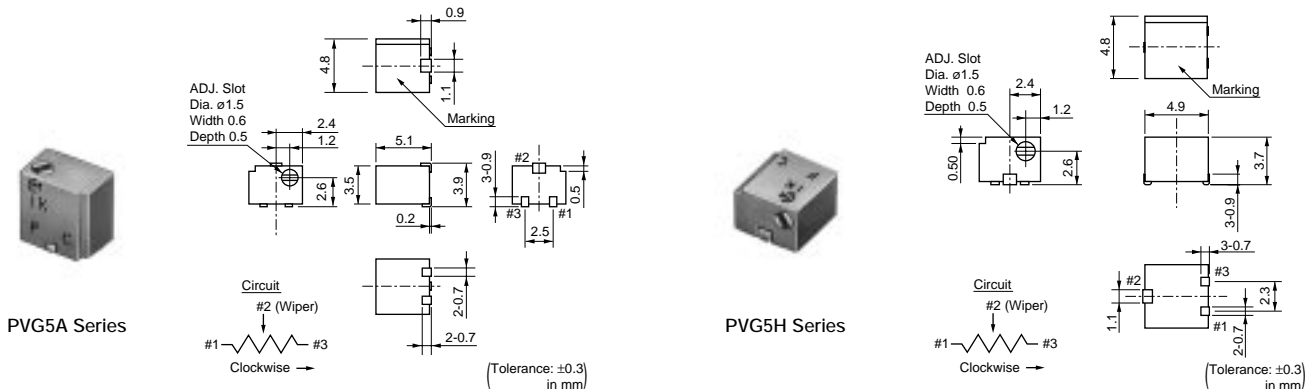

Part Number	Power Rating (W)	Soldering Method	Number of Turns (Effective Rotation Angle)	Total Resistance Value	TCR (ppm/°C)
PVG5A	0.25(70°C)	Reflow/Soldering Iron	11	10ohm to 2M ohm ±10%	±150
PVG5H	0.25(70°C)	Reflow/Soldering Iron	11	10ohm to 2M ohm ±10%	±150

Operating Temperature: -55 to +125°C

The order quantity should be an integral multiple of the "Minimum Quantity" shown in the beginning of this catalog.

Trimmer Potentiometers

Lead Sealed Type Single-turn

● **PV32 Series**

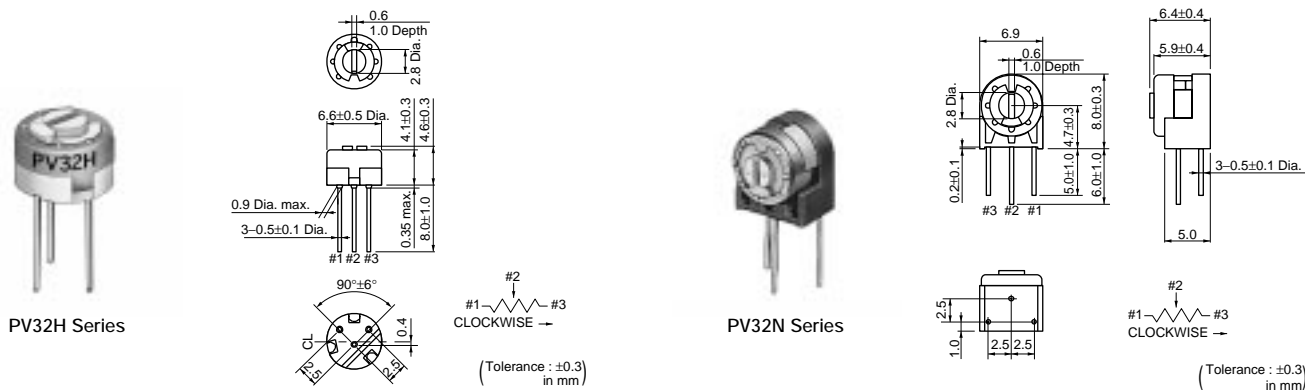

Continued on the following page.

Continued from the preceding page.



PV32P Series

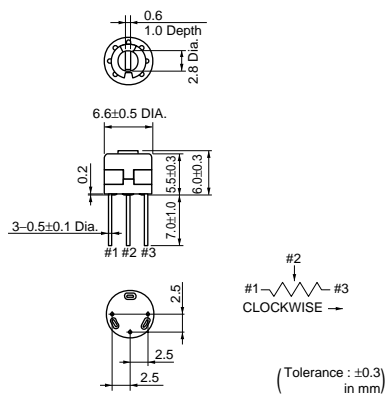

PV32R Series

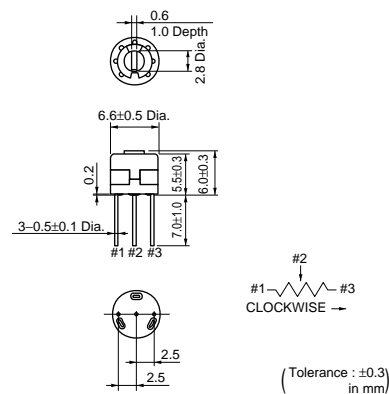

PV32S Series

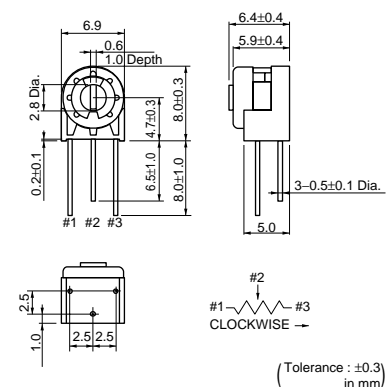

PV32T Series

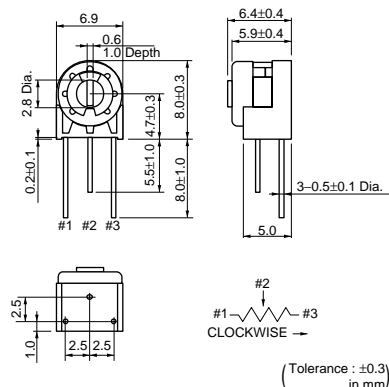

Part Number	Power Rating (W)	Soldering Method	Number of Turns (Effective Rotation Angle)	Total Resistance Value	TCR (ppm/°C)
PV32H	0.5(70°C)	Flow/Soldering Iron	1(230°±5°)	10ohm to 5M ohm ±20%	±100
PV32N	0.5(70°C)	Flow/Soldering Iron	1(230°±5°)	10ohm to 5M ohm ±20%	±100
PV32P	0.5(70°C)	Flow/Soldering Iron	1(230°±5°)	10ohm to 5M ohm ±20%	±100
PV32R	0.5(70°C)	Flow/Soldering Iron	1(230°±5°)	10ohm to 5M ohm ±20%	±100
PV32S	0.5(70°C)	Flow/Soldering Iron	1(230°±5°)	10ohm to 5M ohm ±20%	±100
PV32T	0.5(70°C)	Flow/Soldering Iron	1(230°±5°)	10ohm to 5M ohm ±20%	±100

Operating Temperature: -55 to +125°C

The order quantity should be an integral multiple of the "Minimum Quantity" shown in the beginning of this catalog.

Trimmer Potentiometers

Lead Sealed Type Multi-turns

● PV12 Series



PV12H Series

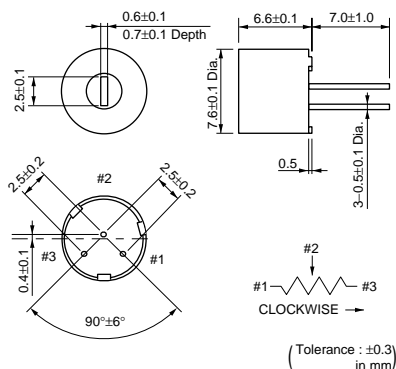

PV12P Series

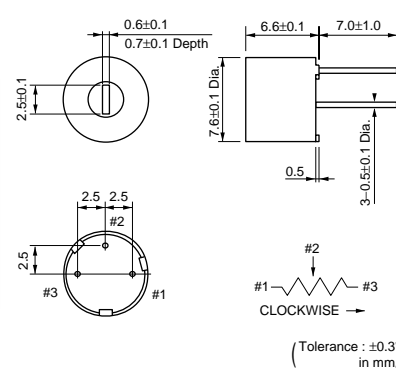

Continued on the following page.

Note • This PDF catalog is downloaded from the website of Murata Manufacturing co., ltd. Therefore, it's specifications are subject to change or our products in it may be discontinued without advance notice. Please check with our sales representatives or product engineers before ordering.
• This PDF catalog has only typical specifications because there is no space for detailed specifications. Therefore, please approve our product specifications or transact the approval sheet for product specifications before ordering.

Continued from the preceding page.

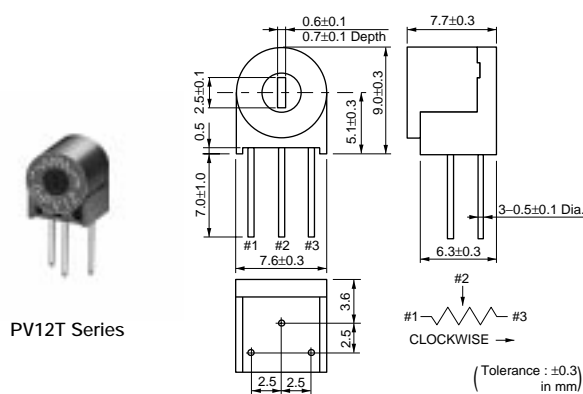
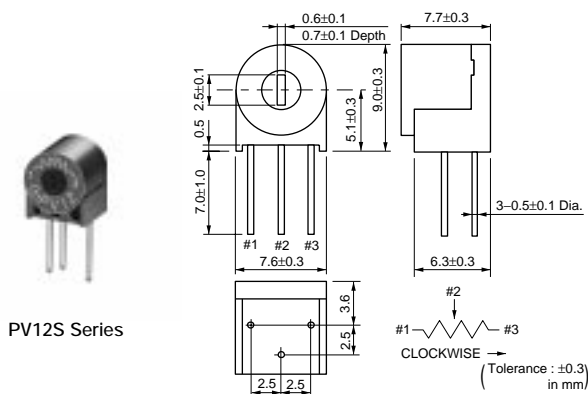

Resistors

Part Number	Power Rating (W)	Soldering Method	Number of Turns (Effective Rotation Angle)	Total Resistance Value	TCR (ppm/°C)
PV12H	0.5(70°C)	Flow/Soldering Iron	4	10ohm to 2M ohm ±10%	±100
PV12P	0.5(70°C)	Flow/Soldering Iron	4	10ohm to 2M ohm ±10%	±100
PV12S	0.5(70°C)	Flow/Soldering Iron	4	10ohm to 2M ohm ±10%	±100
PV12T	0.5(70°C)	Flow/Soldering Iron	4	10ohm to 2M ohm ±10%	±100

Operating Temperature: -55 to +125°C

The order quantity should be an integral multiple of the "Minimum Quantity" shown in the beginning of this catalog.

● PV36 Series

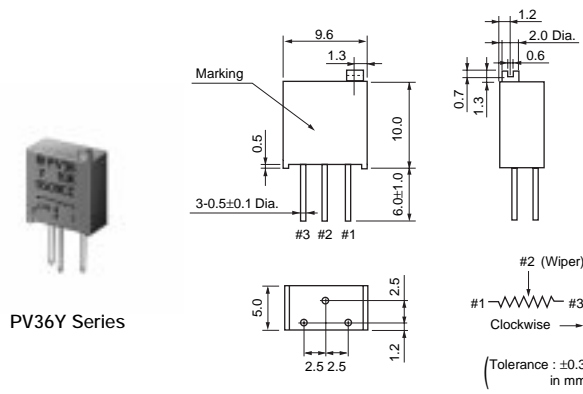
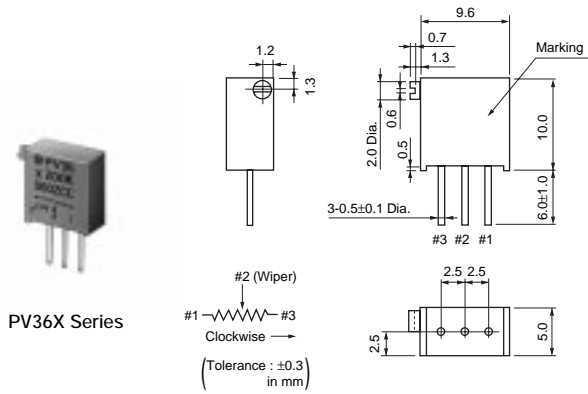
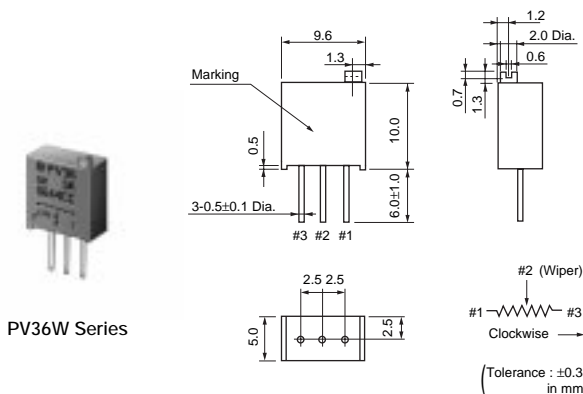
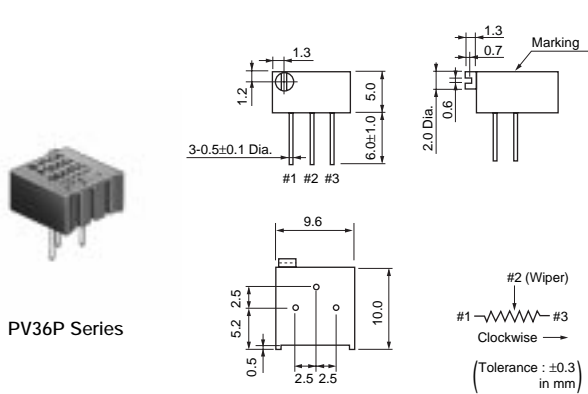

Continued on the following page.

Note • This PDF catalog is downloaded from the website of Murata Manufacturing co., ltd. Therefore, it's specifications are subject to change or our products in it may be discontinued without advance notice. Please check with our sales representatives or product engineers before ordering.
• This PDF catalog has only typical specifications because there is no space for detailed specifications. Therefore, please approve our product specifications or transact the approval sheet for product specifications before ordering.

Continued from the preceding page.

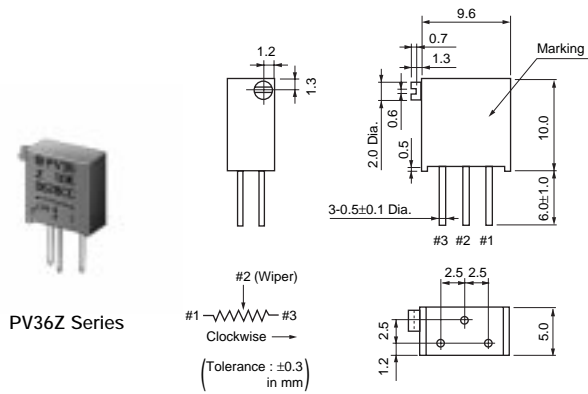

PV36Z Series

Part Number	Power Rating (W)	Soldering Method	Number of Turns (Effective Rotation Angle)	Total Resistance Value	TCR (ppm/°C)
PV36P	0.5(70°C)	Flow/Soldering Iron	25	10ohm to 100ohm ±10%	±150
	0.5(70°C)	Flow/Soldering Iron	25	200ohm to 2M ohm ±10%	±100
PV36W	0.5(70°C)	Flow/Soldering Iron	25	10ohm to 100ohm ±10%	±150
	0.5(70°C)	Flow/Soldering Iron	25	200ohm to 2M ohm ±10%	±100
PV36X	0.5(70°C)	Flow/Soldering Iron	25	10ohm to 100ohm ±10%	±150
	0.5(70°C)	Flow/Soldering Iron	25	200ohm to 2M ohm ±10%	±100
PV36Y	0.5(70°C)	Flow/Soldering Iron	25	10ohm to 100ohm ±10%	±150
	0.5(70°C)	Flow/Soldering Iron	25	200ohm to 2M ohm ±10%	±100
PV36Z	0.5(70°C)	Flow/Soldering Iron	25	10ohm to 100ohm ±10%	±150
	0.5(70°C)	Flow/Soldering Iron	25	200ohm to 2M ohm ±10%	±100

Operating Temperature: -55 to +125°C

The order quantity should be an integral multiple of the "Minimum Quantity" shown in the beginning of this catalog.

● PV37 Series

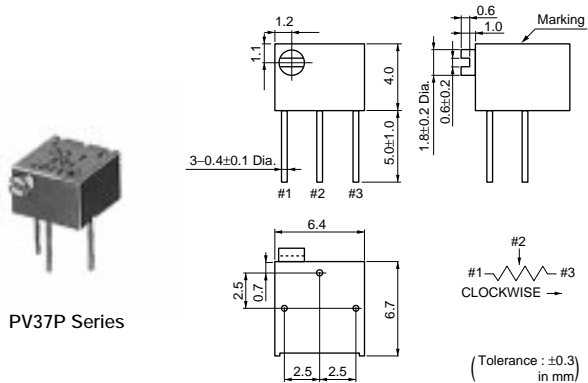

PV37P Series

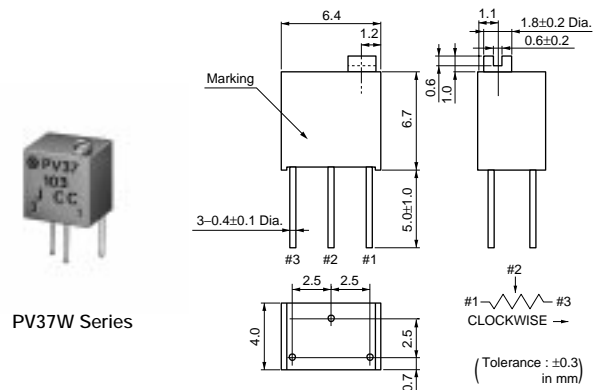

PV37W Series

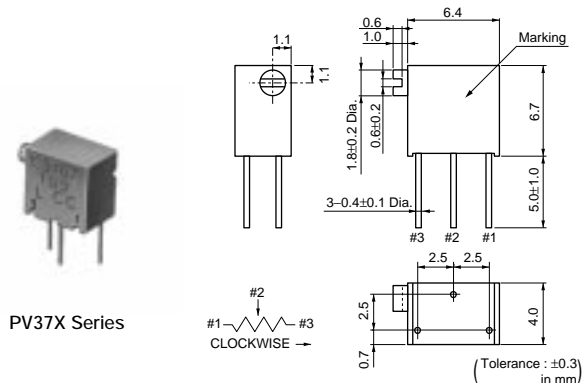

PV37X Series

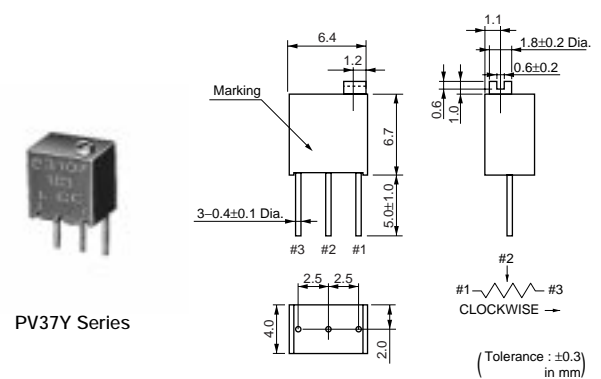

PV37Y Series

Continued on the following page. ↗

△Note • This PDF catalog is downloaded from the website of Murata Manufacturing co., ltd. Therefore, it's specifications are subject to change or our products in it may be discontinued without advance notice. Please check with our sales representatives or product engineers before ordering.
• This PDF catalog has only typical specifications because there is no space for detailed specifications. Therefore, please approve our product specifications or transact the approval sheet for product specifications before ordering.

Continued from the preceding page.



PV37Z Series

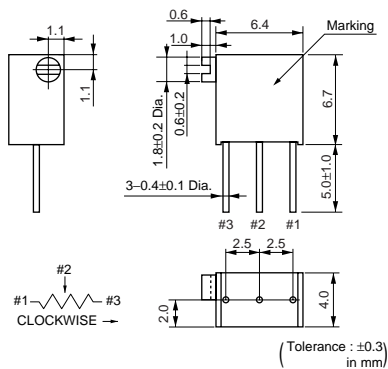

Part Number	Power Rating (W)	Soldering Method	Number of Turns (Effective Rotation Angle)	Total Resistance Value	TCR (ppm/°C)
PV37P	0.25(85°C)	Flow/Soldering Iron	12	10ohm to 2M ohm ±10%	±150
PV37W	0.25(85°C)	Flow/Soldering Iron	12	10ohm to 2M ohm ±10%	±150
PV37X	0.25(85°C)	Flow/Soldering Iron	12	10ohm to 2M ohm ±10%	±150
PV37Y	0.25(85°C)	Flow/Soldering Iron	12	10ohm to 2M ohm ±10%	±150
PV37Z	0.25(85°C)	Flow/Soldering Iron	12	10ohm to 2M ohm ±10%	±150

Operating Temperature: -55 to +125°C

The order quantity should be an integral multiple of the "Minimum Quantity" shown in the beginning of this catalog.

Note • This PDF catalog is downloaded from the website of Murata Manufacturing co., Ltd. Therefore, it's specifications are subject to change or our products in it may be discontinued without advance notice. Please check with our sales representatives or product engineers before ordering.
• This PDF catalog has only typical specifications because there is no space for detailed specifications. Therefore, please approve our product specifications or transact the approval sheet for product specifications before ordering.

5

Resonators

Crystal Resonators

Ceramic Resonators (CERALOCK®)(MHz)

Ceramic Resonators (CERALOCK®)(kHz)

● Part Numbering

Crystal Resonators

(Part Number) **XR** **C** **GA** **33M868** **F0L** **00** **R0**
 ① ② ③ ④ ⑤ ⑥ ⑦

① Product ID

② Lead Style

Code	Lead Style
C	SMD

③ Structure/Size

Code	Structure/Size
GA	Cap Chip Type

④ Nominal Center Frequency

Expressed by five-digit alphanumeric. The unit is in hertz (Hz).
 Decimal point is expressed by capital letter "M".

⑤ Design

Code	Design
F□□	Thickness Expander mode (Fundamental wave)

□□: indicates initial frequency tolerance and application.

⑥ Individual Specification

Code	Design
00	Two-digit alphanumeric express Individual Specification.

00: Standard specification type.

⑦ Packaging

Code	Packaging
R0	Plastic Taping ø180mm
R1	Plastic Taping ø330mm

CERALOCK® (MHz)

(Part Number) **CS** **T** **CE** **16M0** **V** **5** **3** ******* **-R0**
 ① ② ③ ④ ⑤ ⑥ ⑦ ⑧ ⑨

① Product ID

② Frequency/Capacitance

Code	Frequency/Capacitance
A	MHz No capacitance built-in
T	MHz Built-in Capacitance

③ Structure/Size

Code	Structure/Size
LS	Round Lead Type
CC	Cap Chip Type
CR/CE/CG	Small-cap Chip Type
CV	Monolithic Chip Type
CW/CZ	Small Monolithic Chip Type



④ Nominal Center Frequency

Expressed by four-digit alphanumeric. The unit is in hertz (Hz).
 Decimal point is expressed by capital letter "M".

⑤ Design

Code	Design
G	Thickness Shear mode
T/V	Thickness Expander mode
X	Thickness Expander mode (3rd overtone)

⑥ Initial Frequency Tolerance

Code	Design
5	±0.5%
3	±0.3%
2	±0.2%
1	±0.1%
H	±0.07%
K	-0.025/0.02%

⑦ Load Capacity

Code	Design
1	3/5/6pF
2	10pF
3	15pF
4	22pF
5	30/33/39pF
6	47pF

⑧ Individual Specification

⑨ Packaging

CERALOCK® (kHz)

(Part Number) **CS** **B** **FB** **500K** **J58** ******* **-R1**
 ① ② ③ ④ ⑤ ⑥ ⑦

① Product ID

② Frequency/Capacitance

③ Structure/Size

Code	Structure/Size
LA	Two-Terminal Lead Type
FB	SMD Type

④ Nominal Center Frequency

Expressed by four-digit alphanumeric. The unit is in hertz (Hz).
 Capital letter "K" following three figures expresses the unit of "kHz".
 In case of 1.0MHz (1000kHz) or above, expressed by three figures and capital letter "M" for decimal point.

⑤ Design

Code	Design
E□□	Area Expansion mode
J□□	Area Expansion mode (Closed Type)

□□ indicates initial frequency tolerance and load capacitance.

⑥ Individual Specification

⑦ Packaging

△Note • This PDF catalog is downloaded from the website of Murata Manufacturing co., Ltd. Therefore, it's specifications are subject to change or our products in it may be discontinued without advance notice. Please check with our sales representatives or product engineers before ordering.
 • This PDF catalog has only typical specifications because there is no space for detailed specifications. Therefore, please approve our product specifications or transact the approval sheet for product specifications before ordering.

Crystal Resonators

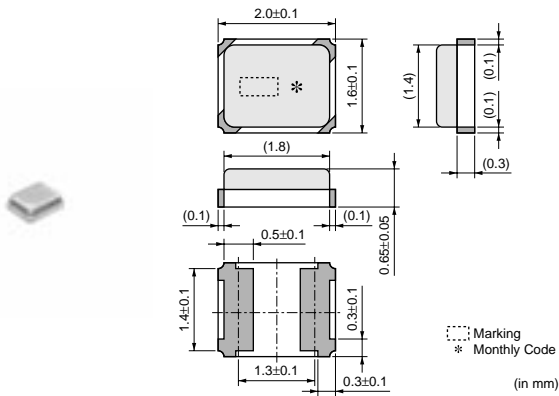

Part Number	Nominal Frequency (MHz)	Frequency Tolerance	Equivalent Series Resistance (ohm)	Temp. Stability	Drive Level (μW)	Load Capacitance (pF)
XRCGA30M000F0L00R0	30.0000	±100ppmmax. (25±3°C)	100 max.	±50ppmmax. (-30 to +85°C)	300 max.	6
XRCGA33M868F0L00R0	33.8688	±100ppmmax. (25±3°C)	100 max.	±50ppmmax. (-30 to +85°C)	300 max.	6
XRCGA40M000F0L00R0	40.0000	±100ppmmax. (25±3°C)	100 max.	±50ppmmax. (-30 to +85°C)	300 max.	6
XRCGA48M000F0L00R0	48.0000	±100ppmmax. (25±3°C)	100 max.	±50ppmmax. (-30 to +85°C)	300 max.	6

Operating Temperature Range: -30 to +85°C

5 Resonators

CERALOCK® (MHz)

● MHz Chip Type for Automotive -Tight Frequency Tolerance-

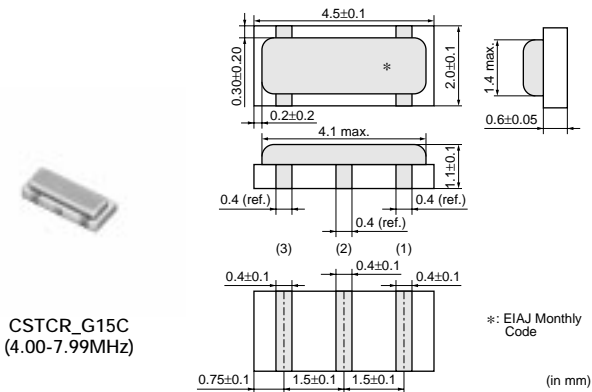

CSTCR_G15C
(4.00-7.99MHz)

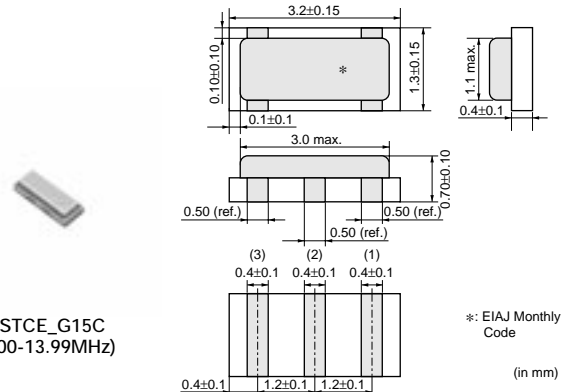

CSTCE_G15C
(8.00-13.99MHz)

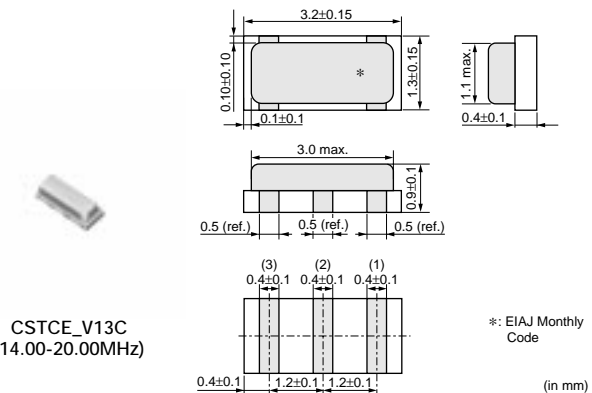

CSTCE_V13C
(14.00-20.00MHz)

△Note • This PDF catalog is downloaded from the website of Murata Manufacturing co., Ltd. Therefore, it's specifications are subject to change or our products in it may be discontinued without advance notice. Please check with our sales representatives or product engineers before ordering.
• This PDF catalog has only typical specifications because there is no space for detailed specifications. Therefore, please approve our product specifications or transact the approval sheet for product specifications before ordering.

Part Number	Oscillating Frequency (MHz)	Initial Tolerance	Temp. Stability (%)	Temp. Range (°C)
CSTCR_G15C	4.00 to 7.99	±0.1%	±0.13	-40 to 125
CSTCE_G15C	8.00 to 13.99	±0.1%	±0.13	-40 to 125
CSTCE_V13C	14.00 to 20.00	±0.1%	±0.13	-40 to 125

Irregular or stop oscillation may occur under unmatched circuit conditions. Please check the actual conditions prior to use.

CSTCE_V13C: The size of external electrode is not same as CSTCE_V.

CSTCR_G15C: The size of external electrode is not same as CSTCR_G and CSTCR_G_B.

● MHz Chip Type for Automotive -Standard Frequency Tolerance-

Resonators 5

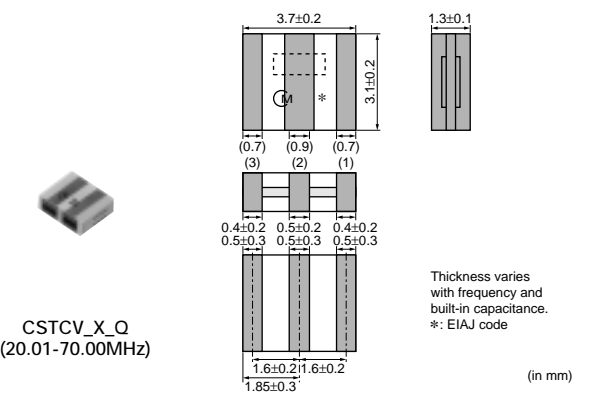
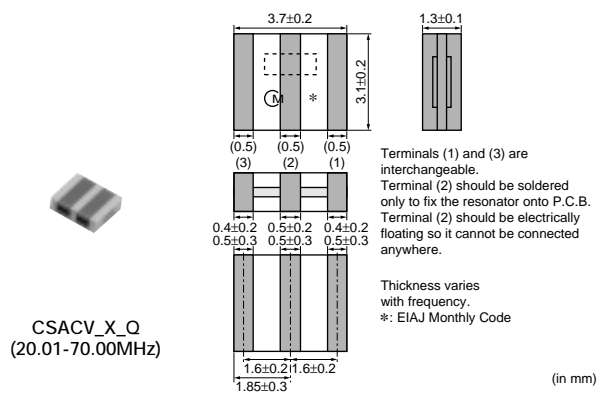
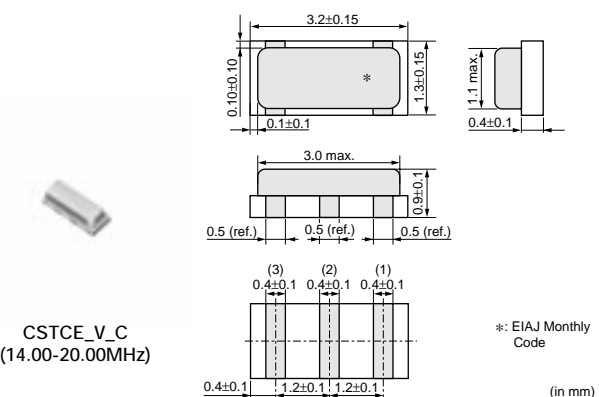
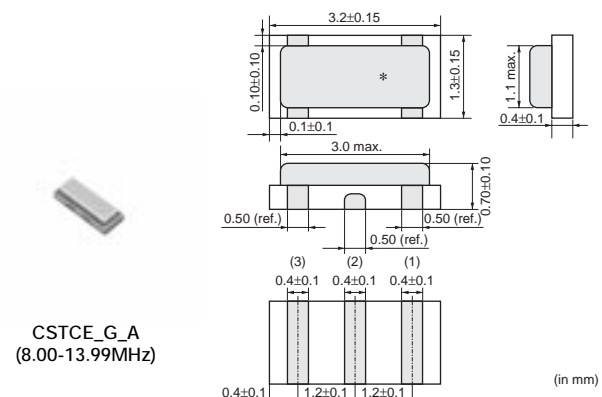
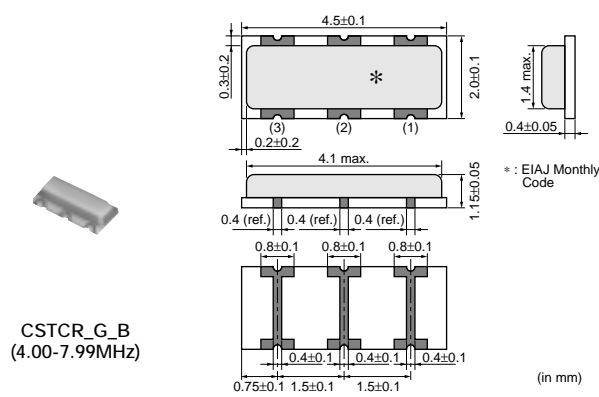
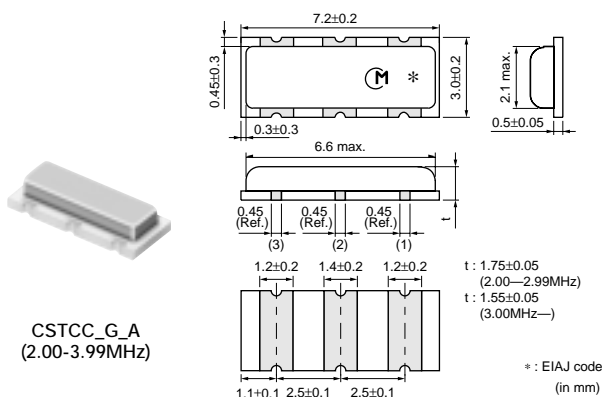

Part Number	Oscillating Frequency (MHz)	Initial Tolerance	Temp. Stability (%)	Temp. Range (°C)
CSTCC_G_A	2.00 to 3.99	±0.5%	±0.4 [-0.6% to +0.3%:Built-in Capacitance 47pF type within Freq.2.00 to 3.49MHz]	-40 to 125
CSTCR_G_B	4.00 to 7.99	±0.5%	±0.15	-40 to 125
CSTCE_G_A	8.00 to 13.99	±0.5%	±0.2	-40 to 125
CSTCE_V_C	14.00 to 20.00	±0.5%	±0.15	-40 to 125
CSACV_X_Q	20.01 to 70.00	±0.5%	±0.3	-40 to 125
CSTCV_X_Q	20.01 to 70.00	±0.5%	±0.3	-40 to 125

Irregular or stop oscillation may occur under unmatched circuit conditions. Please check the actual conditions prior to use.
 CSTCE_V_C: The size of external electrode is not same as CSTCE_V.

● MHz Chip Type for General Usage -Tight Frequency Tolerance-

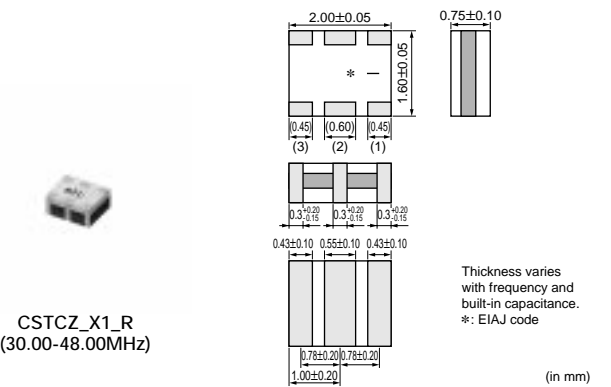
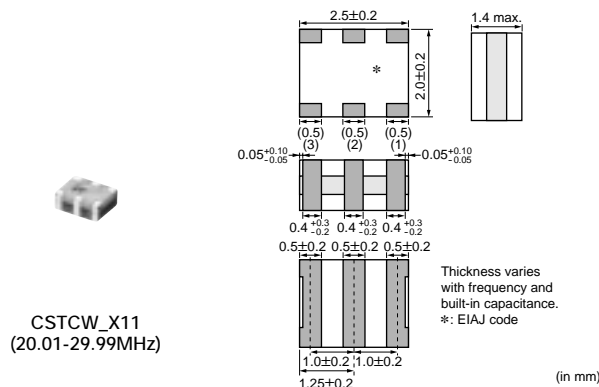
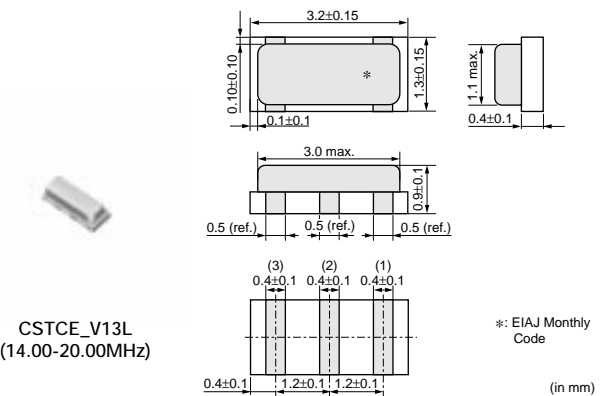
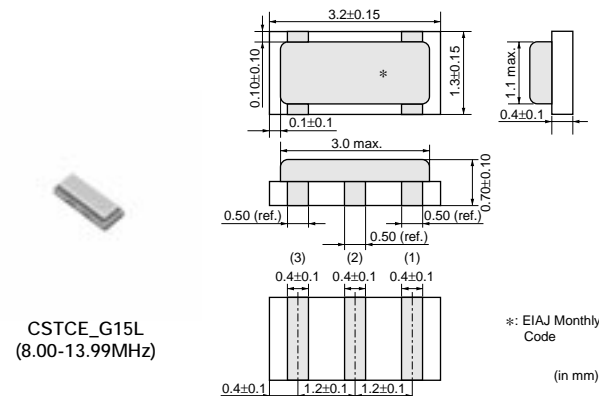
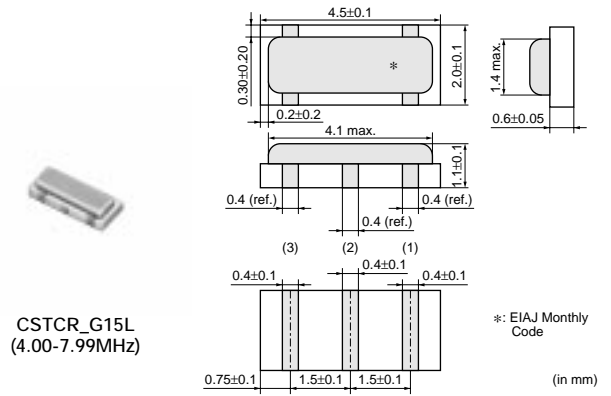
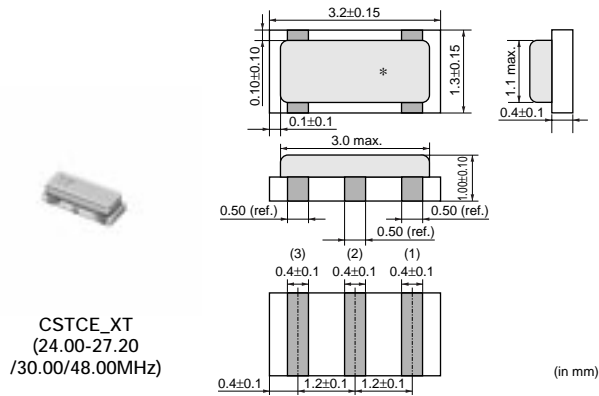

△Note • This PDF catalog is downloaded from the website of Murata Manufacturing co., ltd. Therefore, it's specifications are subject to change or our products in it may be discontinued without advance notice. Please check with our sales representatives or product engineers before ordering.
 • This PDF catalog has only typical specifications because there is no space for detailed specifications. Therefore, please approve our product specifications or transact the approval sheet for product specifications before ordering.

Part Number	Oscillating Frequency (MHz)	Initial Tolerance	Temp. Stability (%)	Temp. Range (°C)
CSTCE_XT	24.00 to 27.20 /30.00/48.00	±0.027%	±0.015	0 to 70
CSTCR_G15L	4.00 to 7.99	±0.1%	±0.08	0 to 70
CSTCE_G15L	8.00 to 13.99	±0.1%	±0.08	0 to 70
CSTCE_V13L	14.00 to 20.00	±0.1%	±0.08	0 to 70
CSTCW_X11	20.01 to 29.99	±0.1%	±0.1	0 to 70
CSTCZ_X1_R	30.00 to 48.00	±0.15%	±0.05 [0 to 70°C:±0.03%]	-30 to 85

Irregular or stop oscillation may occur under unmatched circuit conditions. Please check the actual conditions prior to use.

CSTCE_XT: Initial tolerance is including frequency aging.

CSTCE_V13L: The size of external electrode is not same as CSTCE_V.

● MHz Chip Type for General Usage -Standard Frequency Tolerance-

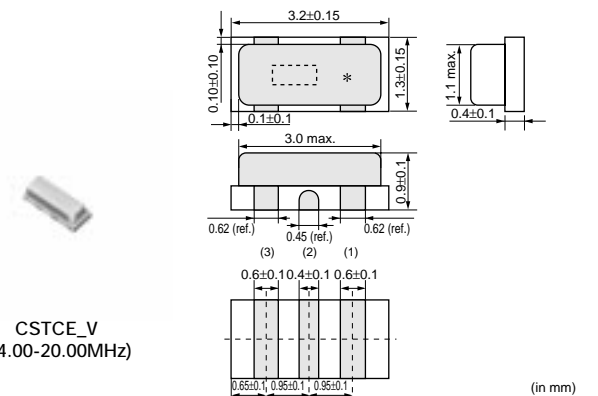
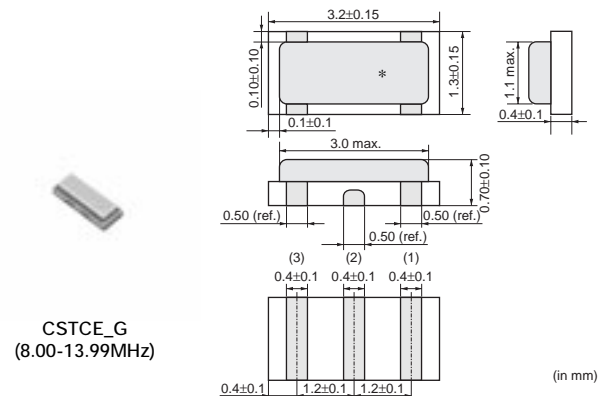
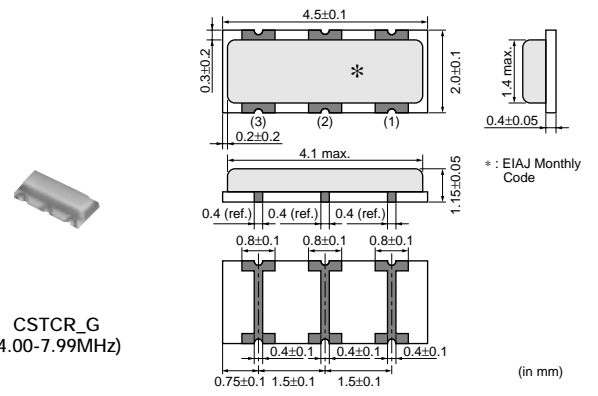
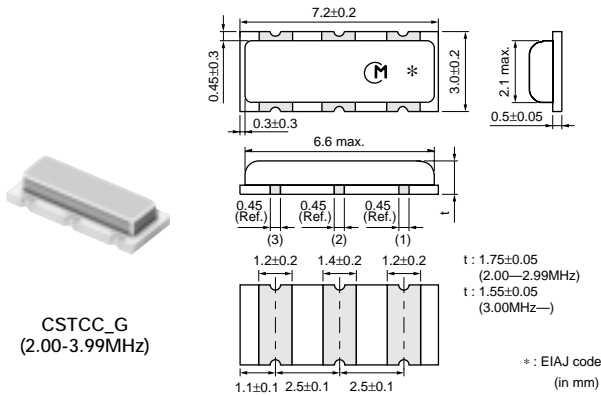

Continued on the following page.

Continued from the preceding page.

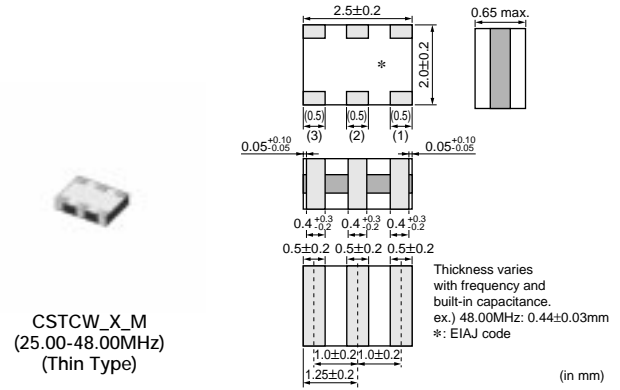
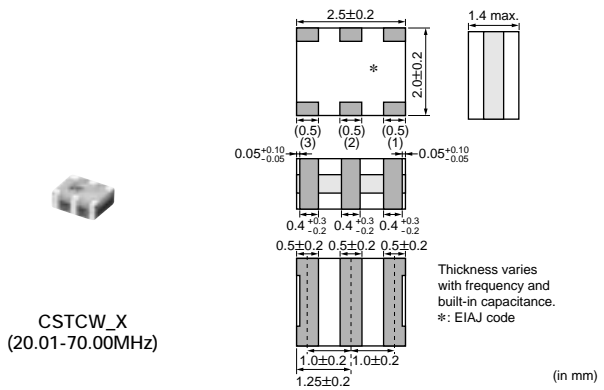
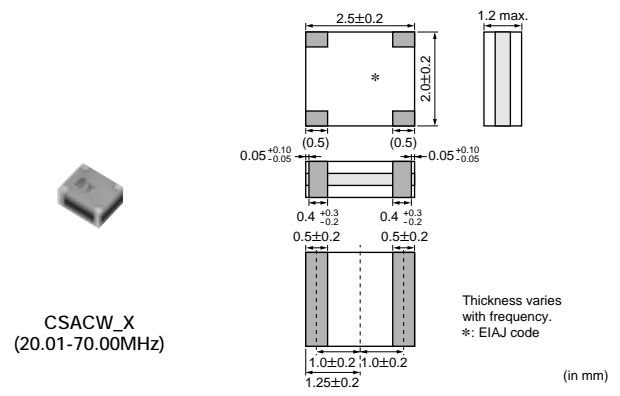
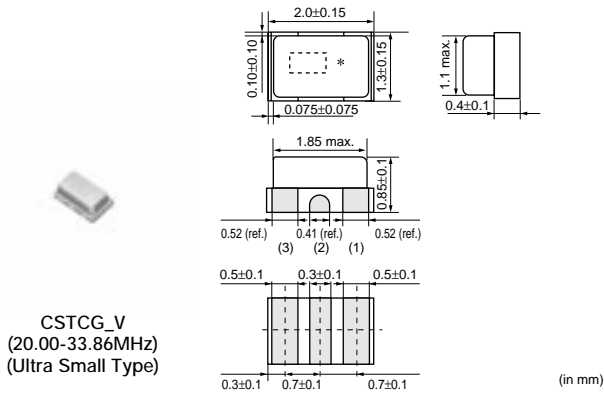

Part Number	Oscillating Frequency (MHz)	Initial Tolerance	Temp. Stability (%)	Temp. Range (°C)
CSTCC_G	2.00 to 3.99	±0.5%	±0.3 [±0.4%:Built-in Capacitance 47pF type within Freq.2.00 to 3.49MHz]	-20 to 80
CSTCR_G	4.00 to 7.99	±0.5%	±0.2	-20 to 80
CSTCE_G	8.00 to 13.99	±0.5%	±0.2	-20 to 80
CSTCE_V	14.00 to 20.00	±0.5%	±0.3	-20 to 80
CSTCG_V	20.00 to 33.86	±0.5%	±0.3	-20 to 80
CSACW_X	20.01 to 70.00	±0.5%	±0.2	-20 to 80
CSTCW_X	20.01 to 70.00	±0.5%	±0.2	-20 to 80
CSTCW_X_M	25.00 to 48.00	±0.5%	±0.2	-20 to 80

Irregular or stop oscillation may occur under unmatched circuit conditions. Please check the actual conditions prior to use.
CSTCE_V: The size of external electrode is not same as CSTCE_V_C and CSTCE_V13C.

△Note • This PDF catalog is downloaded from the website of Murata Manufacturing co., ltd. Therefore, it's specifications are subject to change or our products in it may be discontinued without advance notice. Please check with our sales representatives or product engineers before ordering.
• This PDF catalog has only typical specifications because there is no space for detailed specifications. Therefore, please approve our product specifications or transact the approval sheet for product specifications before ordering.

● MHz Lead Type for General Usage -Standard Frequency Tolerance-

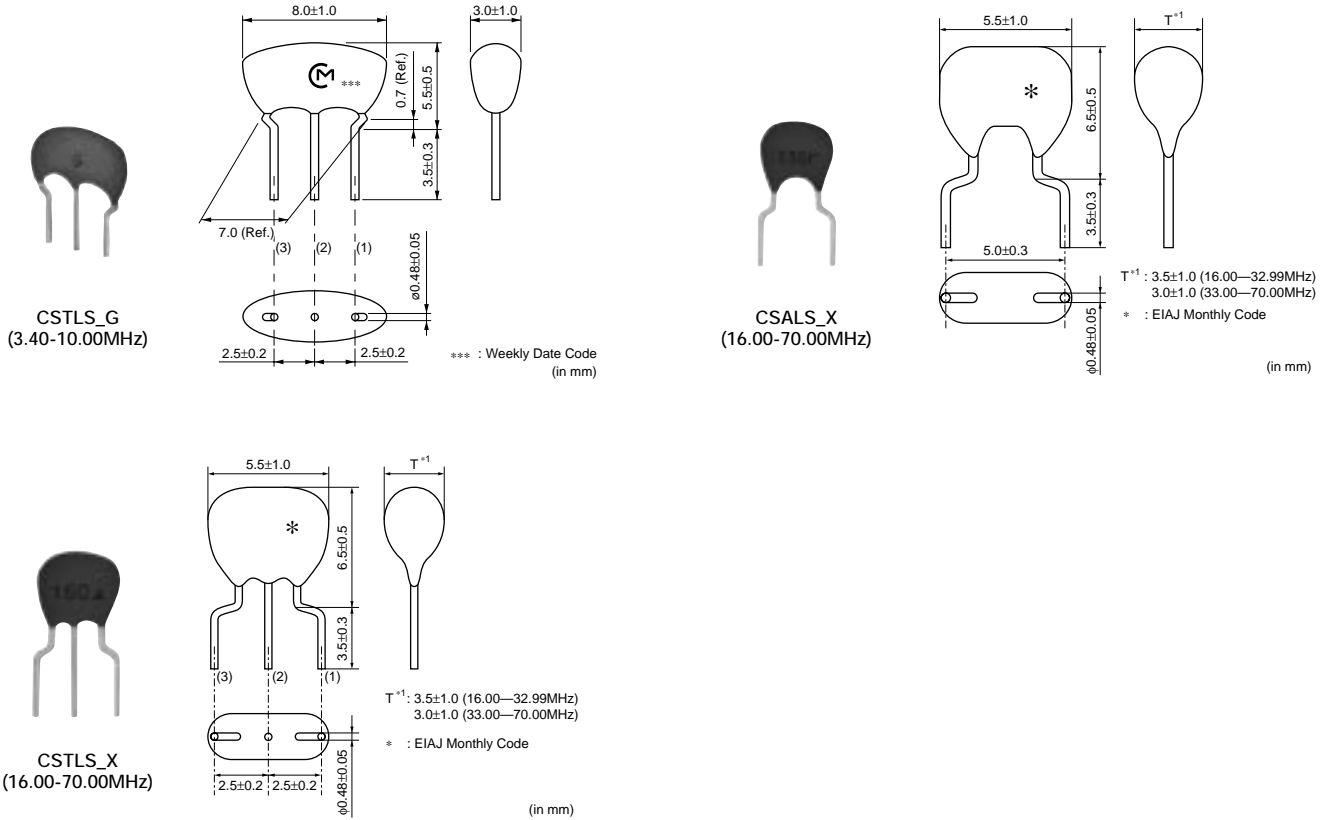

Resonators 5

Part Number	Oscillating Frequency (MHz)	Initial Tolerance	Temp. Stability (%)	Temp. Range (°C)
CSTLS_G	3.40 to 10.00	±0.5%	±0.2 [-0.4% to +0.2%:Built-in Capacitance 47pF type]	-20 to 80
CSALS_X	16.00 to 70.00	±0.5%	±0.2	-20 to 80
CSTLS_X	16.00 to 70.00	±0.5%	±0.2	-20 to 80

Irregular or stop oscillation may occur under unmatched circuit conditions. Please check the actual conditions prior to use.
The order quantity should be an integral multiple of the "Minimum Quantity" shown in the beginning of this catalog.

CERALOCK® (kHz)

● Chip Type Two Terminals CSBFB Series

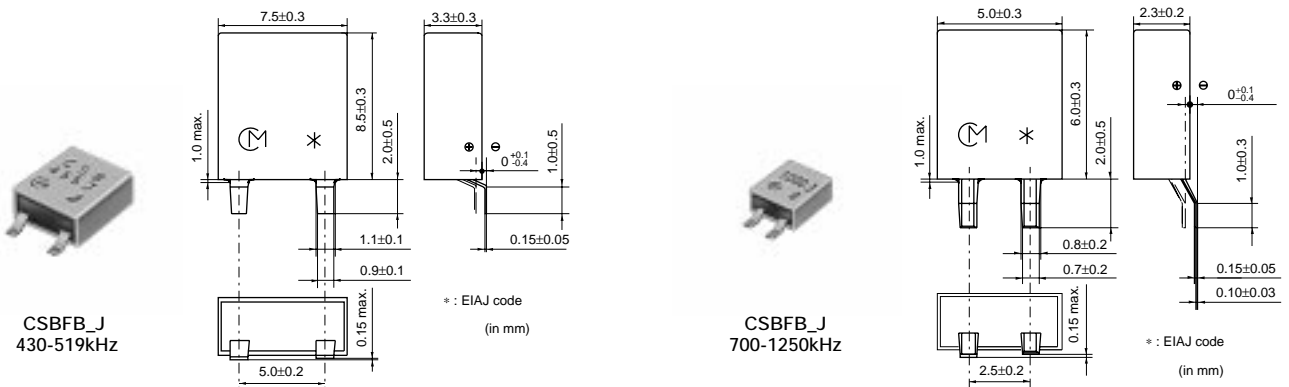

Part Number	Oscillating Frequency (kHz)	Initial Tolerance	Temp. Stability (%)	Temp. Range (°C)
CSBFB_J	430 to 519, 700 to 1250	±0.5%	±0.3	-20 to 80

Irregular or stop oscillation may occur under unmatched circuit conditions. Please check the actual conditions prior to use.

● Lead Type Two Terminals CSBLA Series



CSBLA_E
375-429kHz

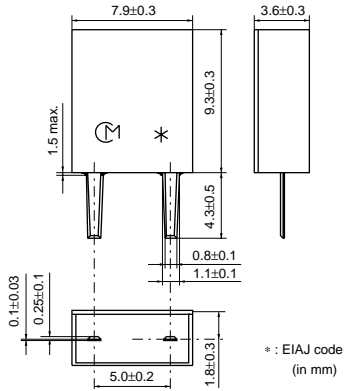

CSBLA_E
430-509kHz

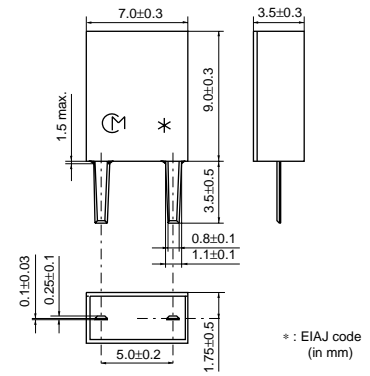

CSBLA_E
510-699kHz

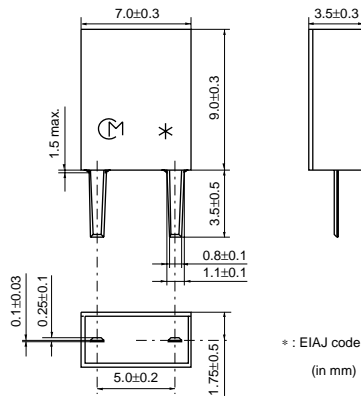

CSBLA_J
700-1250kHz

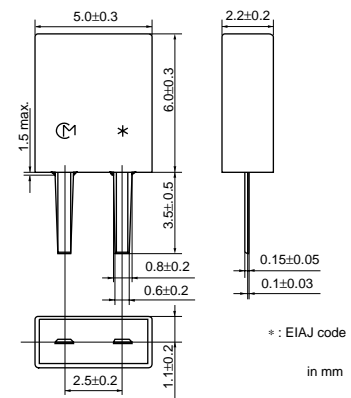

Part Number	Oscillating Frequency (kHz)	Initial Tolerance	Temp. Stability (%)	Temp. Range (°C)
CSBLA_E	375 to 699	-	±0.3	-20 to +80
CSBLA_J	700 to 1250	±0.5%	±0.3	-20 to 80

Irregular or stop oscillation may occur under unmatched circuit conditions. Please check the actual conditions prior to use.

The order quantity should be an integral multiple of the "Minimum Quantity" shown in the beginning of this catalog.

Resonators 5

△Note • This PDF catalog is downloaded from the website of Murata Manufacturing co., ltd. Therefore, it's specifications are subject to change or our products in it may be discontinued without advance notice. Please check with our sales representatives or product engineers before ordering.
• This PDF catalog has only typical specifications because there is no space for detailed specifications. Therefore, please approve our product specifications or transact the approval sheet for product specifications before ordering.

6

Filters for Audio Visual Equipment

CERAFIL[®] for AM

CERAFIL[®] for FM

Discriminators for FM

CERAFIL[®] for TV/VCR

Traps for TV/VCR

SAW Traps

● Part Numbering

CERAFIL® for AM

(Part Number) **SF** **P** **KA** **455K** **D4A** **-R0**
 ① ② ③ ④ ⑤ ⑥

- ① Product ID
- ② Oscillation/Numbers of Element

Code	Oscillation/Numbers of Element
U	1 Element Area Expansion mode
Z	2 Elements Area Expansion mode
P	4 Elements Area Expansion mode

- ③ Structure/Size
- ④ Nominal Center Frequency
Expressed by four-digit alphanumerics. The unit is in hertz (Hz). Capital letter "K" following three figures expresses the unit of "kHz".
- ⑤ Product Specification
- ⑥ Packaging

CERAFIL® for FM

(Part Number) **SF** **E** **LF** **10M7** **FAA0** **-B0**
 ① ② ③ ④ ⑤ ⑥

- ① Product ID
- ② Oscillation/Numbers of Element

Code	Oscillation/Numbers of Element
E	2 Elements Thickness Expander mode
V	2 Elements Thickness Expander mode (2nd Harmonic)
K	2 Elements Thickness Expander mode (3rd Over Tone)

- ③ Structure/Size
- ④ Nominal Center Frequency
Expressed by four-digit alphanumerics. The unit is in hertz (Hz). If the unit is "MHz", a decimal point is expressed by capital letter "M".
- ⑤ Product Specification
- ⑥ Packaging

Discriminators for FM

(Part Number) **CD** **A** **LF** **10M7** **GA** **001** **-B0**
 ① ② ③ ④ ⑤ ⑥ ⑦

- ① Product ID
- ② Oscillation

Code	Oscillation
A	Thickness Expander mode
S	Thickness Shear mode

- ③ Structure/Size
- ④ Nominal Center Frequency
Expressed by four-digit alphanumerics. The unit is in hertz (Hz). If the unit is "MHz", a decimal point is expressed by capital letter "M".
- ⑤ Product Specification
- ⑥ IC
- ⑦ Packaging

CERAFIL® for TV/VCR

(Part Number) **SF** **S** **KA** **4M50** **CF** **00** **-R1**
 ① ② ③ ④ ⑤ ⑥ ⑦

- ① Product ID
- ② Oscillation/Numbers of Element

Code	Oscillation/Numbers of Element
S	2 Elements Thickness Shear mode

- ③ Structure/Size
- ④ Nominal Center Frequency
Expressed by four-digit alphanumerics. The unit is in hertz (Hz). If the unit is "MHz", a decimal point is expressed by capital letter "M".
- ⑤ Product Specification Code (1)
- ⑥ Product Specification Code (2)
- ⑦ Packaging

Ceramic Traps

(Part Number) **TP** **S** **KA** **4M00** **B** **00** **-R0**
① ② ③ ④ ⑤ ⑥ ⑦

- ① Product ID
- ② Trap Point

Code	Trap Point
S	Single Traps
W	Double Traps

- ③ Structure/Size
- ④ Nominal Center Frequency
Expressed by four-digit alphanumerics. The unit is in hertz (Hz). If the unit is "MHz", a decimal point is expressed by capital letter "M".
- ⑤ Product Specification Code (1)
- ⑥ Product Specification Code (2)
- ⑦ Packaging

Ceramic Filters (CERAFIL®) for AM

● Chip Type SFPKA Series

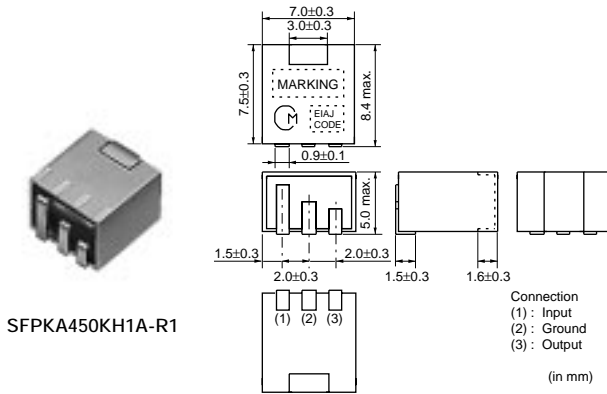

SFPKA450KH1A-R1

Part Number	Center Frequency (fo) (kHz)	6dB Bandwidth (kHz)	Selectivity (+) (dB)	Selectivity (-) (dB)	Insertion Loss (dB)	Input/Output Impedance (ohm)	Elements
SFPKA450KH1A-R1	450.0 ±1.0kHz	fn±3.0 min.	40 min.[fn+9kHz]	40 min.[fn-9kHz]	6.0 max.	2000	4
SFPKA450KG1A-R1	450.0 ±1.0kHz	fn±4.5 min.	40 min.[fn+10kHz]	40 min.[fn-10kHz]	6.0 max.	1500	4

Area of Insertion Loss: at minimum loss point

Center frequency (fo) is defined by the center of 6dB bandwidth.

(fn) means nominal center frequency (450kHz).

For safety purposes, connect the output of filters to the IF amplifier through a D.C. blocking capacitor. Avoid applying a direct current to the output of ceramic filters.

The order quantity should be an integral multiple of the "Minimum Quantity" shown in the package page.

● SFULA/SFZLA Series

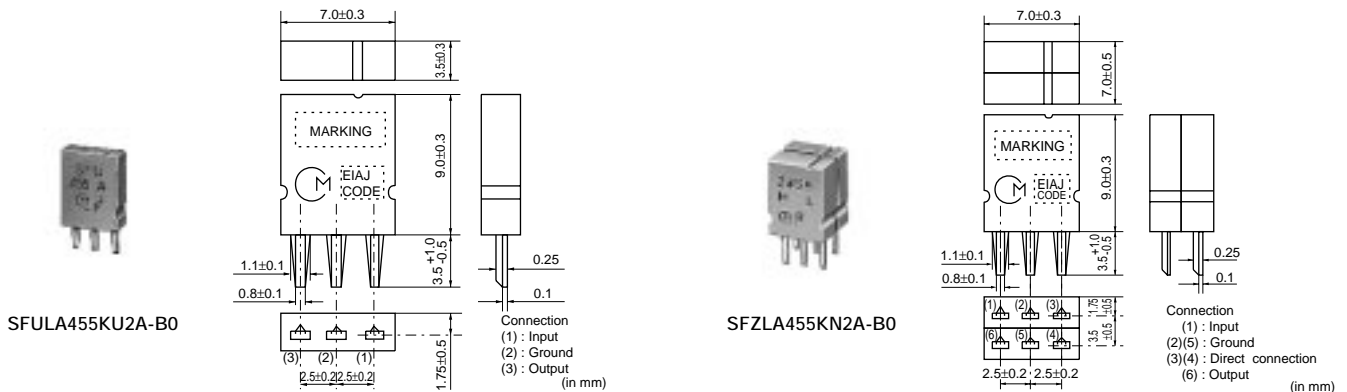

SFULA455KU2A-B0

SFZLA455KN2A-B0

Part Number	Center Frequency (fo) (kHz)	3dB Bandwidth (kHz)	Selectivity (+) (dB)	Selectivity (-) (dB)	Insertion Loss (dB)	Input/Output Impedance (ohm)	Elements
SFULA455KU2A-B0	455.0 ±2.0kHz	10.0 ±3.0kHz	4 min.[fo+10kHz]	6 min.[fo-10kHz]	5.0 max.	3000	1
SFULA455KU2B-B0	462.0 ±2.0kHz	10.0 ±3.0kHz	4 min.[fo+10kHz]	6 min.[fo-10kHz]	5.0 max.	3000	1
SFZLA455KN2A-B0	455.5 ±2.0kHz	4.0 ±1.0kHz	23 min.[fo+9kHz]	23 min.[fo-9kHz]	7.0 max.	3000	2
SFZLA455KS2A-B0	456.0 ±2.0kHz	5.5 ±1.0kHz	18 min.[fo+9kHz]	18 min.[fo-9kHz]	7.0 max.	3000	2
SFZLA455KT2A-B0	456.0 ±2.0kHz	7.0 ±1.0kHz	16 min.[fo+9kHz]	16 min.[fo-9kHz]	6.0 max.	3000	2

Area of Insertion Loss: at minimum loss point

Center frequency (fo) is defined by the center of 3dB bandwidth.

For safety purposes, connect the output of filters to the IF amplifier through a D.C. blocking capacitor. Avoid applying a direct current to the output of ceramic filters.

The order quantity should be an integral multiple of the "Minimum Quantity" shown in the beginning of this catalog.

● SFPLA/CFWLA Series

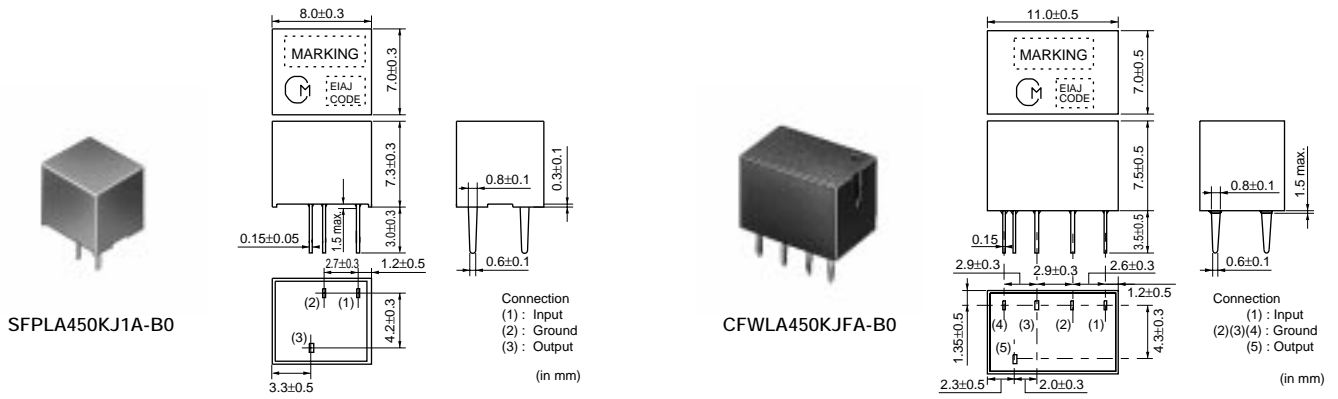

Part Number	Center Frequency (fo) (kHz)	6dB Bandwidth (kHz)	Selectivity (+) (dB)	Selectivity (-) (dB)	Insertion Loss (dB)	Input/Output Impedance (ohm)	Elements
SFPLA450KJ1A-B0	450.0 ±1.0kHz	fn±2.0 min.	40 min.[fn+7.5kHz]	40 min.[fn-7.5kHz]	6.0 max.	2000	4
SFPLA450KH1A-B0	450.0 ±1.0kHz	fn±3.0 min.	40 min.[fn+9kHz]	40 min.[fn-9kHz]	6.0 max.	2000	4
CFWLA450KJFA-B0	450.0 (fn)	fn±2.0 min.	50 min.[fn+7.5kHz]	50 min.[fn-7.5kHz]	7.0 max.	2000	6
CFWLA450KHFA-B0	450.0 (fn)	fn±3.0 min.	50 min.[fn+9kHz]	50 min.[fn-9kHz]	6.0 max.	2000	6

Area of Insertion Loss: at minimum loss point

Center frequency (fo) is defined by the center of 6dB bandwidth.

(fn) means nominal center frequency (450kHz)

For safety purposes, connect the output of filters to the IF amplifier through a D.C. blocking capacitor. Avoid applying a direct current to the output of ceramic filters.

The order quantity should be an integral multiple of the "Minimum Quantity" shown in the beginning of this catalog.

● SFPLA/CFWLA/CFULA Series (For AM Stereo Wide Band Type)

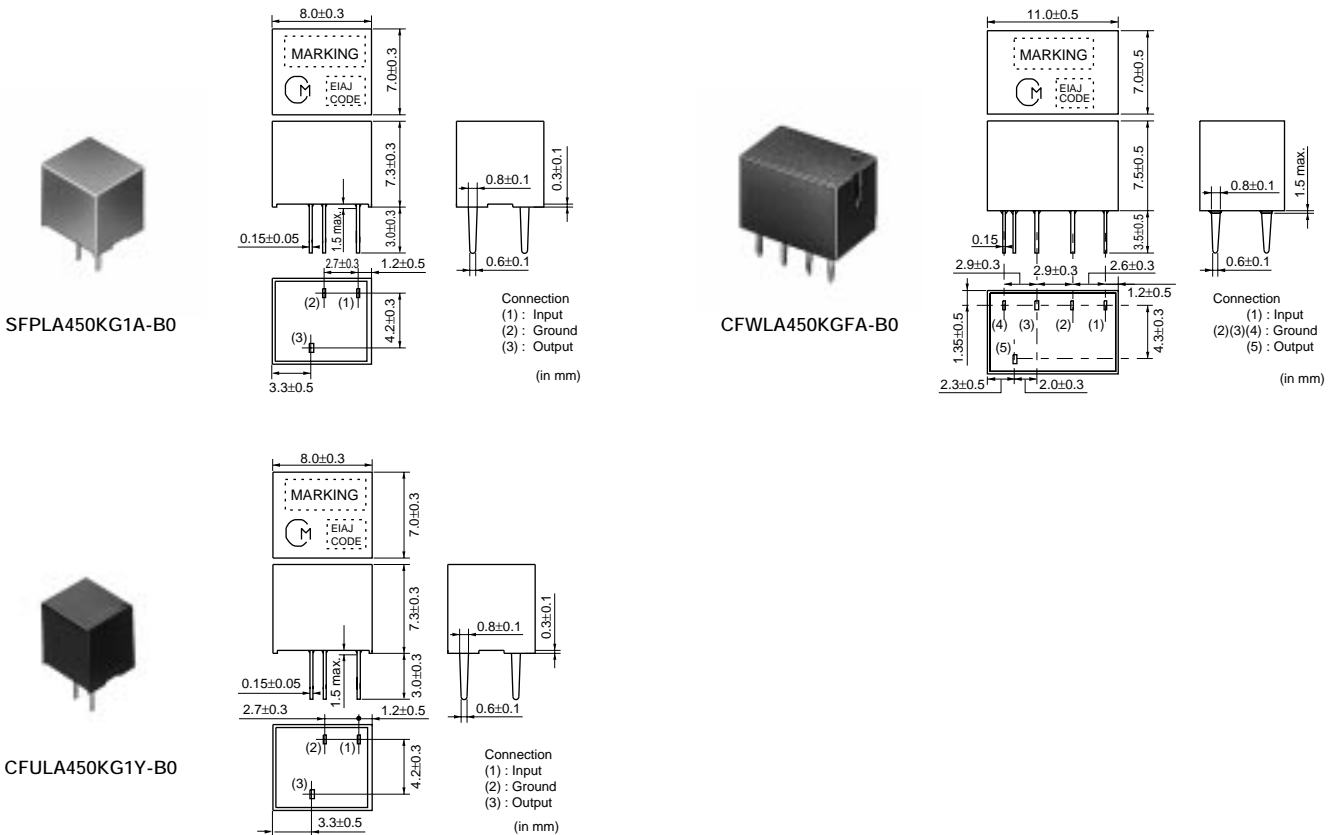

Part Number	Center Frequency (fo) (kHz)	6dB Bandwidth (kHz)	Selectivity (+) (dB)	Selectivity (-) (dB)	Insertion Loss (dB)	GDT 20μsec. Bandwidth (kHz)	Input/Output Impedance (ohm)	Elements
SFPLA450KG1A-B0	450.0 ±1.0kHz	fn±4.5 min.	30 min.[fn+9kHz]	30 min.[fn-9kHz]	6.0 max.	-	2000	4
SFPLA450KF1A-B0	450.0 ±1.0kHz	fn±6.0 min.	40 min.[fn+12.5kHz]	40 min.[fn-12.5kHz]	6.0 max.	-	2000	4
SFPLA450KE1A-B0	450.0 ±1.0kHz	fn±7.5 min.	40 min.[fn+15kHz]	40 min.[fn-15kHz]	6.0 max.	-	1500	4

Continued on the following page.

△Note • This PDF catalog is downloaded from the website of Murata Manufacturing co., ltd. Therefore, it's specifications are subject to change or our products in it may be discontinued without advance notice. Please check with our sales representatives or product engineers before ordering.
• This PDF catalog has only typical specifications because there is no space for detailed specifications. Therefore, please approve our product specifications or transact the approval sheet for product specifications before ordering.

Continued from the preceding page.

Part Number	Center Frequency (fo) (kHz)	6dB Bandwidth (kHz)	Selectivity (+) (dB)	Selectivity (-) (dB)	Insertion Loss (dB)	GDT 20μsec. Bandwidth (kHz)	Input/Output Impedance (ohm)	Elements
SFPLA450KD1A-B0	450.0 ±1.0kHz	fn±10.0 min.	40 min.[fn+20kHz]	40 min.[fn-20kHz]	4.0 max.	-	1500	4
CFWLA450KGFA-B0	450.0 (fn)	fn±4.5 min.	50 min.[fn+10kHz]	50 min.[fn-10kHz]	6.0 max.	-	2000	6
CFWLA450KFFA-B0	450.0 (fn)	fn±6.0 min.	50 min.[fn+12.5kHz]	50 min.[fn-12.5kHz]	6.0 max.	-	2000	6
CFWLA450KEFA-B0	450.0 (fn)	fn±7.5 min.	50 min.[fn+15kHz]	50 min.[fn-15kHz]	6.0 max.	-	1500	6
CFWLA450KDFA-B0	450.0 (fn)	fn±10.0 min.	50 min.[fn+20kHz]	50 min.[fn-20kHz]	4.0 max.	-	1500	6
CFWLA450KG1Y-B0	450.0 ±1.0kHz	fn±4.5 min.	50 min.[fn+15kHz]	50 min.[fn-15kHz]	11.0 max.	fn±4	2000	6
CFWLA450KF1Y-B0	450.0 ±1.0kHz	fn±6.0 min.	50 min.[fn+17.5kHz]	50 min.[fn-17.5kHz]	10.0 max.	fn±5	2000	6
CFWLA450KD1Y-B0	450.0 ±1.0kHz	fn±10.0 min.	50 min.[fn+25kHz]	50 min.[fn-25kHz]	8.0 max.	fn±8	1500	6
CFULA450KG1Y-B0	450.0 ±1.0kHz	fn±4.5 min.	40 min.[fn+15kHz]	40 min.[fn-15kHz]	10.0 max.	fn±3	2000	4
CFULA450KF1Y-B0	450.0 ±1.0kHz	fn±6.0 min.	40 min.[fn+17.5kHz]	40 min.[fn-17.5kHz]	9.0 max.	fn±4	2000	4
CFULA450KD1Y-B0	450.0 ±1.0kHz	fn±10.0 min.	40 min.[fn+25kHz]	40 min.[fn-25kHz]	7.0 max.	fn±7	1500	4

Area of Insertion Loss: at minimum loss point

Center frequency (fo) is defined by the center of 6dB bandwidth.

(fn) means nominal center frequency (450kHz)

For safety purposes, connect the output of filters to the IF amplifier through a D.C. blocking capacitor. Avoid applying a direct current to the output of ceramic filters.

The order quantity should be an integral multiple of the "Minimum Quantity" shown in the beginning of this catalog.

Ceramic Filters (CERAFIL®) for FM

6

Filters for Audio Visual Equipment

● Chip Type SFECF Series (Standard Type)

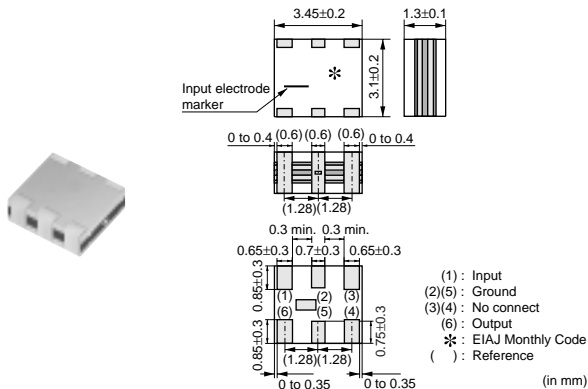

Part Number	Center Frequency (fo) (MHz)	Nominal Center Frequency (fn) (MHz)	3dB Bandwidth (kHz)	Attenuation (kHz)	Insertion Loss (dB)	Ripple (dB)	Spurious Attenuation (1) (dB)	Input/Output Impedance (ohm)	Spurious Attenuation (2) (dB)
SFECF10M7HA00-R0	10.700 ±30kHz	-	180 ±40kHz	470 max.	4.0 ±2.0dB	1.0 max.	30 min. [within 9MHz to fo]	330	30 min. [within fo to 12MHz]
SFECF10M7HF00-R0	-	10.700	fn±25 min.	510 max.	8.0 max. [at fn]	1.0 max.	30 min. [within 9MHz to fn]	330	25 min. [within fn to 12MHz]
SFECF10M7GA00-R0	10.700 ±30kHz	-	230 ±50kHz	510 max.	3.5 ±2.0dB	1.0 max.	30 min. [within 9MHz to fo]	330	30 min. [within fo to 12MHz]
SFECF10M7GF00-R0	-	10.700	fn±45 min.	560 max.	8.0 max. [at fn]	1.0 max.	30 min. [within 9MHz to fn]	330	25 min. [within fn to 12MHz]
SFECF10M7FA00-R0	10.700 ±30kHz	-	280 ±50kHz	590 max.	3.0 ±2.0dB	1.0 max.	30 min. [within 9MHz to fo]	330	30 min. [within fo to 12MHz]
SFECF10M7FF00-R0	-	10.700	fn±65 min.	620 max.	7.0 max. [at fn]	1.0 max.	30 min. [within 9MHz to fn]	330	25 min. [within fn to 12MHz]
SFECF10M7EA00-R0	10.700 ±30kHz	-	330 ±50kHz	700 max.	3.0 ±2.0dB	1.0 max.	30 min. [within 9MHz to fo]	330	30 min. [within fo to 12MHz]
SFECF10M7DA0001-R0	10.700 ±30kHz	-	420 min.	950 max.	3.0 ±2.0dB	3.0 max.	35 min. [within 9MHz to fo]	330	25 min. [within fo to 12MHz]

Continued on the following page.

Continued from the preceding page.

Part Number	Center Frequency (fo) (MHz)	Nominal Center Frequency (fn) (MHz)	3dB Bandwidth (kHz)	Attenuation (kHz)	Insertion Loss (dB)	Ripple (dB)	Spurious Attenuation (1) (dB)	Input/Output Impedance (ohm)	Spurious Attenuation (2) (dB)
SFECF10M7DF00-R0	-	10.700	fn±150 min.	990 max.	6.0 max. [at fn]	3.0 max.	20 min. [within 9MHz to fn]	330	20 min. [within fn to 12MHz]

Area of Attenuation: [within 20dB]

Area of Spurious Attenuation: [within 9MHz to 12MHz]

Area of Insertion Loss: at minimum loss point

Area of Ripple: within 3dB B.W.

Center frequency (fo) defined by the center of 3dB bandwidth.

For safety purposes, connect the output of filters to the IF amplifier through a D.C. blocking capacitor. Avoid applying a direct current to the output of ceramic filters.

The order quantity should be an integral multiple of the "Minimum Quantity" shown in the package page.

● Chip Type SFECF Series (High-reliability Type)

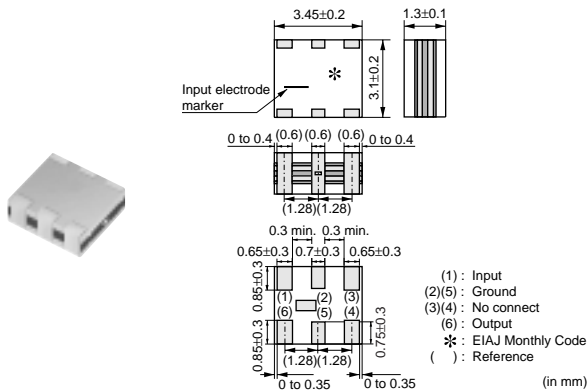

Part Number	Center Frequency (fo) (MHz)	Nominal Center Frequency (fn) (MHz)	3dB Bandwidth (kHz)	Attenuation (kHz)	Insertion Loss (dB)	Ripple (dB)	Spurious Attenuation (1) (dB)	Input/Output Impedance (ohm)	Spurious Attenuation (2) (dB)
SFECF10M7HA00S0-R0	10.700 ±30kHz	-	180 ±40kHz	470 max.	4.0 ±2.0dB	1.0 max.	30 min. [within 9MHz to fo]	330	30 min. [within fo to 12MHz]
SFECF10M7HF00S0-R0	-	10.700	fn±25 min.	510 max.	8.0 max. [at fn]	1.0 max.	30 min. [within 9MHz to fn]	330	25 min. [within fn to 12MHz]
SFECF10M7GA00S0-R0	10.700 ±30kHz	-	230 ±50kHz	510 max.	3.5 ±2.0dB	1.0 max.	30 min. [within 9MHz to fo]	330	30 min. [within fo to 12MHz]
SFECF10M7GF00S0-R0	-	10.700	fn±45 min.	560 max.	8.0 max. [at fn]	1.0 max.	30 min. [within 9MHz to fn]	330	25 min. [within fn to 12MHz]
SFECF10M7FA00S0-R0	10.700 ±30kHz	-	280 ±50kHz	590 max.	3.0 ±2.0dB	1.0 max.	30 min. [within 9MHz to fo]	330	30 min. [within fo to 12MHz]
SFECF10M7FF00S0-R0	-	10.700	fn±65 min.	630 max.	7.0 max. [at fn]	1.0 max.	30 min. [within 9MHz to fn]	330	25 min. [within fn to 12MHz]
SFECF10M7EA00S0-R0	10.700 ±30kHz	-	330 ±50kHz	700 max.	3.0 ±2.0dB	1.0 max.	30 min. [within 9MHz to fo]	330	30 min. [within fo to 12MHz]
SFECF10M7DF00S0-R0	-	10.700	fn±145 min.	990 max.	6.0 max. [at fn]	3.0 max.	20 min. [within 9MHz to fn]	330	20 min. [within fn to 12MHz]

Area of Attenuation: [within 20dB]

Area of Spurious Attenuation: [within 9MHz to 12MHz]

Area of Insertion Loss: at minimum loss point

Area of Ripple: within 3dB B.W.

Center frequency (fo) defined by the center of 3dB bandwidth.

For safety purposes, connect the output of filters to the IF amplifier through a D.C. blocking capacitor. Avoid applying a direct current to the output of ceramic filters.

The order quantity should be an integral multiple of the "Minimum Quantity" shown in the package page.

△Note • This PDF catalog is downloaded from the website of Murata Manufacturing co., ltd. Therefore, it's specifications are subject to change or our products in it may be discontinued without advance notice. Please check with our sales representatives or product engineers before ordering.
• This PDF catalog has only typical specifications because there is no space for detailed specifications. Therefore, please approve our product specifications or transact the approval sheet for product specifications before ordering.

● Chip Type SFECK Series (High-reliability Type)

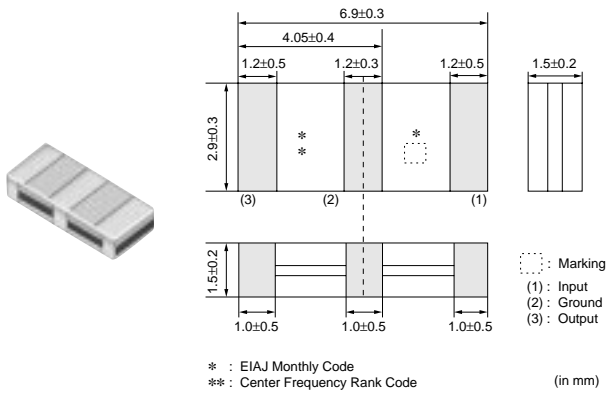

Part Number	Center Frequency (fo) (MHz)	Nominal Center Frequency (fn)	3dB Bandwidth (kHz)	Attenuation (kHz)	Insertion Loss (dB)	Spurious Attenuation (1) (dB)	Input/Output Impedance (ohm)	Spurious Attenuation (2) (dB)
SFECK10M7JA00S0-R0	10.700 ±30kHz	-	150 ±40kHz	380 max.	5.5 ±2.0dB	35 min.	330	35 min.
SFECK10M7KA00S0-R0	10.700 ±30kHz	-	110 ±30kHz	320 max.	6.0 ±2.0dB	35 min.	330	35 min.

Area of Attenuation: [within 20dB]

Area of Spurious Attenuation: [within 9MHz to 12MHz]

Area of Insertion Loss: at minimum loss point

Area of Ripple: within 3dB B.W.

Center frequency (fo) defined by the center of 3dB bandwidth.

For safety purposes, connect the output of filters to the IF amplifier through a D.C. blocking capacitor. Avoid applying a direct current to the output of ceramic filters.

The order quantity should be an integral multiple of the "Minimum Quantity" shown in the package page.

6

Filters for Audio Visual Equipment

● Chip Type SFECV Series

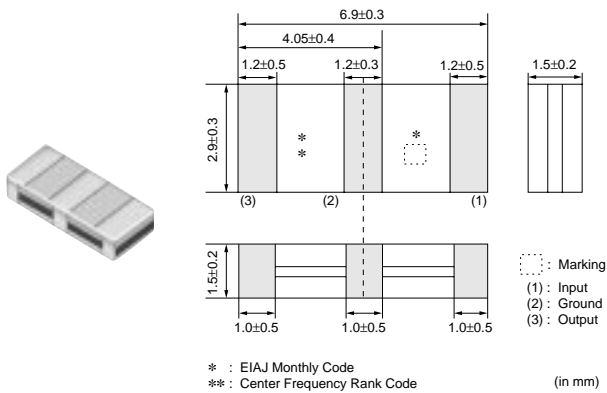

Part Number	Center Frequency (fo) (MHz)	Nominal Center Frequency (fn)	3dB Bandwidth (kHz)	Attenuation (kHz)	Insertion Loss (dB)	Ripple (dB)	Spurious Attenuation (1) (dB)	Input/Output Impedance (ohm)	Spurious Attenuation (2) (dB)
SFECV15M0EQ0001-R0	15.000 ±50kHz	-	300 min.	750 max.	7.0 max.	1.0 max.	30 min.	330	30 min.
SFECV10M7KA00-R0	10.700 ±30kHz	-	110 ±30kHz	320 max.	6.0 ±2.0dB	1.0 max.	35 min.	330	35 min.
SFECV10M7JA00-R0	10.700 ±30kHz	-	150 ±40kHz	380 max.	5.5 ±2.0dB	1.0 max.	35 min.	330	35 min.

Area of Attenuation: [within 20dB]

Area of Spurious Attenuation: [within 9MHz to 12MHz], SFECV15M0EQ0001-R0: [within 14MHz to fo/fo to 16MHz]

Area of Insertion Loss: at minimum loss point

Center frequency (fo) defined by the center of 3dB bandwidth.

For safety purposes, connect the output of filters to the IF amplifier through a D.C. blocking capacitor. Avoid applying a direct current to the output of ceramic filters.

The order quantity should be an integral multiple of the "Minimum Quantity" shown in the package page.

● Standard Lead Type

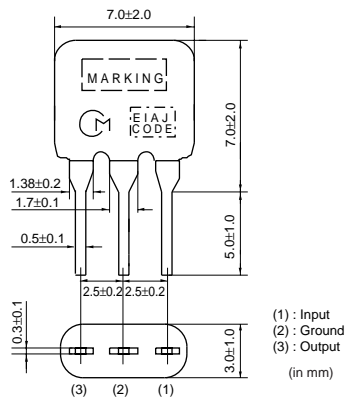

Part Number	Center Frequency (fo) (MHz)	3dB Bandwidth (kHz)	Attenuation (kHz)	Insertion Loss (dB)	Spurious Attenuation (1) (dB)	Input/Output Impedance (ohm)	Spurious Attenuation (2) (dB)
SFELF10M7HA00-B0	10.700 ±30kHz	180 ±40kHz	520 max.	7.0 max.	40 min.	330	40 min.
SFELF10M7GA00-B0	10.700 ±30kHz	230 ±50kHz	570 max.	4.0 ±2.0dB	40 min.	330	40 min.
SFELF10M7FA00-B0	10.700 ±30kHz	280 ±50kHz	650 max.	4.0 ±2.0dB	30 min.	330	30 min.

Area of Attenuation: [within 20dB]

Area of Spurious Attenuation: [within 9MHz to 12MHz]

Area of Insertion Loss: at minimum loss point

Center frequency (fo) defined by the center of 3dB bandwidth.

For safety purposes, connect the output of filters to the IF amplifier through a D.C. blocking capacitor. Avoid applying a direct current to the output of ceramic filters.

The order quantity should be an integral multiple of the "Minimum Quantity" shown in the package page.

● Low Loss Type

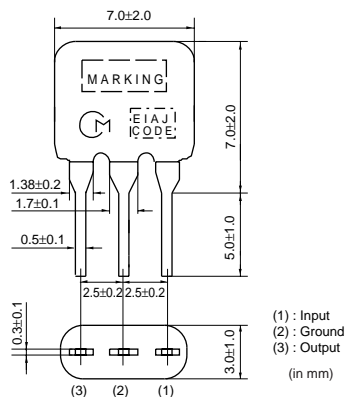

Part Number	Center Frequency (fo) (MHz)	3dB Bandwidth (kHz)	Attenuation (kHz)	Insertion Loss (dB)	Spurious Attenuation (1) (dB)	Input/Output Impedance (ohm)	Spurious Attenuation (2) (dB)
SFELF10M7JAA0-B0	10.700 ±30kHz	150 ±40kHz	360 max.	4.5 ±2.0dB	35 min.	330	35 min.
SFELF10M7HAA0-B0	10.700 ±30kHz	180 ±40kHz	470 max.	3.5 ±1.5dB	35 min.	330	35 min.
SFELF10M7GAA0-B0	10.700 ±30kHz	230 ±50kHz	520 max.	3.0 ±2.0dB	35 min.	330	35 min.
SFELF10M7FAA0-B0	10.700 ±30kHz	280 ±50kHz	590 max.	2.5 ±2.0dB	30 min.	330	30 min.

Area of Attenuation: [within 20dB]

Area of Spurious Attenuation: [within 9MHz to 12MHz]

Area of Insertion Loss: at minimum loss point

Center frequency (fo) defined by the center of 3dB bandwidth.

For safety purposes, connect the output of filters to the IF amplifier through a D.C. blocking capacitor. Avoid applying a direct current to the output of ceramic filters.

The order quantity should be an integral multiple of the "Minimum Quantity" shown in the package page.

△Note • This PDF catalog is downloaded from the website of Murata Manufacturing co., ltd. Therefore, it's specifications are subject to change or our products in it may be discontinued without advance notice. Please check with our sales representatives or product engineers before ordering.
• This PDF catalog has only typical specifications because there is no space for detailed specifications. Therefore, please approve our product specifications or transact the approval sheet for product specifications before ordering.

● Low Profile Type

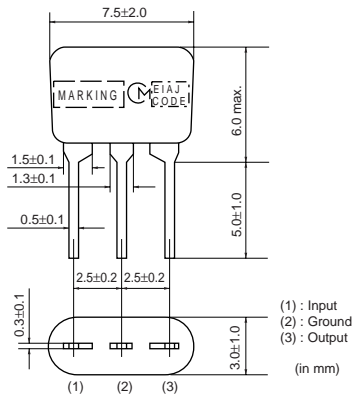

Part Number	Center Frequency (fo) (MHz)	3dB Bandwidth (kHz)	Attenuation (kHz)	Insertion Loss (dB)	Spurious Attenuation (1) (dB)	Input/Output Impedance (ohm)	Spurious Attenuation (2) (dB)
SFELG10M7KA00-B0	10.700 ±30kHz	110 ±30kHz	350 max.	7.0 ±2.0dB	30 min.	330	30 min.
SFELG10M7JA00-B0	10.700 ±30kHz	150 ±40kHz	360 max.	4.5 ±2.0dB	35 min.	330	35 min.
SFELG10M7HA00-B0	10.700 ±30kHz	180 ±40kHz	470 max.	3.5 ±2.0dB	35 min.	330	35 min.
SFELG10M7GA00-B0	10.700 ±30kHz	230 ±50kHz	570 max.	3.0 ±2.0dB	40 min.	330	40 min.
SFELG10M7FA00-B0	10.700 ±30kHz	280 ±50kHz	650 max.	3.0 ±2.0dB	30 min.	330	30 min.

Area of Attenuation: [within 20dB]

Area of Spurious Attenuation: [within 9MHz to 12MHz]

Area of Insertion Loss: at minimum loss point

Center frequency (fo) defined by the center of 3dB bandwidth.

For safety purposes, connect the output of filters to the IF amplifier through a D.C. blocking capacitor. Avoid applying a direct current to the output of ceramic filters.

The order quantity should be an integral multiple of the "Minimum Quantity" shown in the package page.

● Lower Spurious Response Type

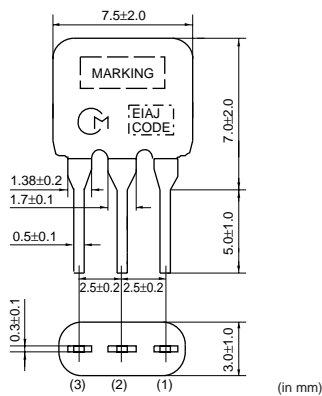

Part Number	Center Frequency (fo) (MHz)	3dB Bandwidth (kHz)	Attenuation (kHz)	Insertion Loss (dB)	Spurious Attenuation (1) (dB)	Input/Output Impedance (ohm)	Spurious Attenuation (2) (dB)
SFELF10M7KAB0-B0	10.700 ±30kHz	110 ±30kHz	350 max.	7.0 ±2.0dB	45/30 min.	330	30 min.
SFELF10M7JAB0-B0	10.700 ±30kHz	150 ±40kHz	380 max.	5.5 ±2.0dB	45 min.	330	45 min.
SFELF10M7HAB0-B0	10.700 ±30kHz	180 ±40kHz	520 max.	5.0 ±2.0dB	45 min.	330	45 min.
SFELF10M7GAB0-B0	10.700 ±30kHz	230 ±50kHz	570 max.	3.0 ±2.0dB	45 min.	330	45 min.

Continued on the following page.

Note • This PDF catalog is downloaded from the website of Murata Manufacturing co., Ltd. Therefore, it's specifications are subject to change or our products in it may be discontinued without advance notice. Please check with our sales representatives or product engineers before ordering.
• This PDF catalog has only typical specifications because there is no space for detailed specifications. Therefore, please approve our product specifications or transact the approval sheet for product specifications before ordering.

Continued from the preceding page.

Part Number	Center Frequency (fo) (MHz)	3dB Bandwidth (kHz)	Attenuation (kHz)	Insertion Loss (dB)	Spurious Attenuation (1) (dB)	Input/Output Impedance (ohm)	Spurious Attenuation (2) (dB)
SFELF10M7FAB0-B0	10.700 ±30kHz	280 ±50kHz	650 max.	3.0 ±2.0dB	45 min.	330	45 min.

Area of Attenuation: [within 20dB]

Area of Spurious Attenuation: [within 9MHz to 12MHz], SFELF10M7KAB0-B0: [within 9MHz to fo/fo to 12MHz]

Area of Insertion Loss: at minimum loss point

Center frequency (fo) defined by the center of 3dB bandwidth.

For safety purposes, connect the output of filters to the IF amplifier through a D.C. blocking capacitor. Avoid applying a direct current to the output of ceramic filters.

The order quantity should be an integral multiple of the "Minimum Quantity" shown in the package page.

Wider Band Width Type

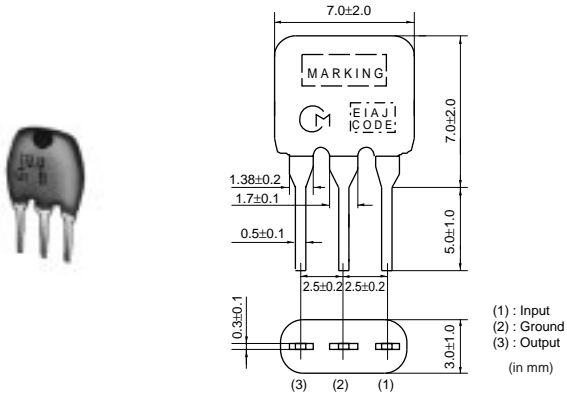

Part Number	Center Frequency (fo) (MHz)	Nominal Center Frequency (fn) (MHz)	3dB Bandwidth (kHz)	Attenuation (kHz)	Insertion Loss (dB)	Spurious Attenuation (1) (dB)	Input/Output Impedance (ohm)	Spurious Attenuation (2) (dB)
SFELF10M7EA00-B0	10.700 ±30kHz	-	330 ±50kHz	680 max.	4.0 ±2.0dB	30 min.	330	30 min.
SFELF10M7DF00-B0	-	10.700	fn±175 min.	950 max.	3.0 ±2.0dB	20 min.	470	20 min.

Area of Attenuation: [within 20dB]

Area of Spurious Attenuation: SFELF10M7DF00-B0: [within 5MHz to 15MHz]

Area of Insertion Loss: at minimum loss point

Center frequency (fo) defined by the center of 3dB bandwidth.

For safety purposes, connect the output of filters to the IF amplifier through a D.C. blocking capacitor. Avoid applying a direct current to the output of ceramic filters.

The order quantity should be an integral multiple of the "Minimum Quantity" shown in the package page.

Narrow Band Type

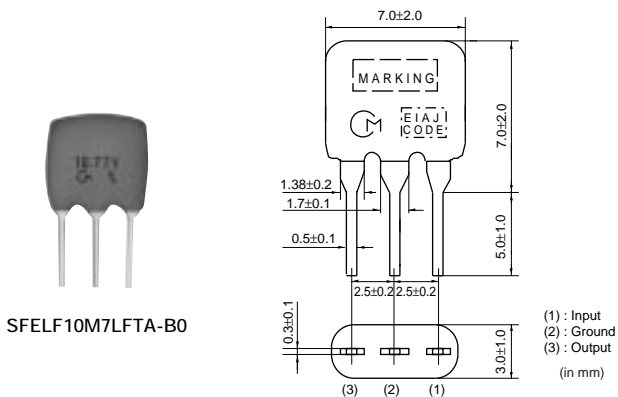

SFELF10M7LFTA-B0

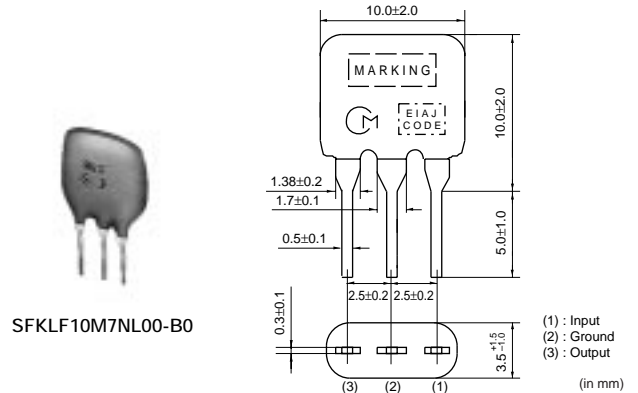

SFKLF10M7NL00-B0

Continued on the following page.

Note • This PDF catalog is downloaded from the website of Murata Manufacturing co., ltd. Therefore, it's specifications are subject to change or our products in it may be discontinued without advance notice. Please check with our sales representatives or product engineers before ordering.
• This PDF catalog has only typical specifications because there is no space for detailed specifications. Therefore, please approve our product specifications or transact the approval sheet for product specifications before ordering.

Continued from the preceding page.



SFVLF10M7LF00-B0

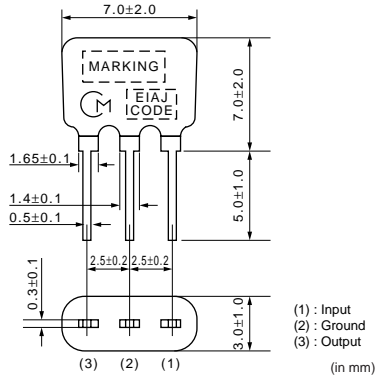

Part Number	Center Frequency (fo) (MHz)	Nominal Center Frequency (fn) (MHz)	3dB Bandwidth (kHz)	Attenuation (kHz)	Insertion Loss (dB)	Spurious Attenuation (1) (dB)	Input/Output Impedance (ohm)	Spurious Attenuation (2) (dB)
SFELF10M7KAH0-B0	10.700 ±30kHz	-	110 ±30kHz	350 max.	7.0 ±2.0dB	30 min.	330	30 min.
SFELF10M7LFTA-B0	-	10.700	fn±25 min.	280 max.	7.0 ±2.0dB	30 min.	330	30 min.
SFKLF10M7NL00-B0	10.700 ±15kHz	-	20 min.	95 max.	6.0 max.	24 min.	600	24 min.
SFVLF10M7LF00-B0	-	10.700	fn±25 min.	-	5.5 ±2.5dB	30 min.	330	30 min.
SFVLF10M7MF00-B0	-	10.700	fn±13 min.	135 max.	5.0 ±2.0dB	35 min.	330	35 min.

Area of Attenuation: [within 20dB]

Area of Spurious Attenuation: [within 9MHz to 12MHz], SFKLF10M7NL00-B0: [within fo-1.0MHz to fo+1.0MHz]

Area of Insertion Loss: at minimum loss point

Center frequency (fo) defined by the center of 3dB bandwidth.

For safety purposes, connect the output of filters to the IF amplifier through a D.C. blocking capacitor. Avoid applying a direct current to the output of ceramic filters.

The order quantity should be an integral multiple of the "Minimum Quantity" shown in the package page.

● For FM -IF Tuners



SFELF10M7HA0G-B0

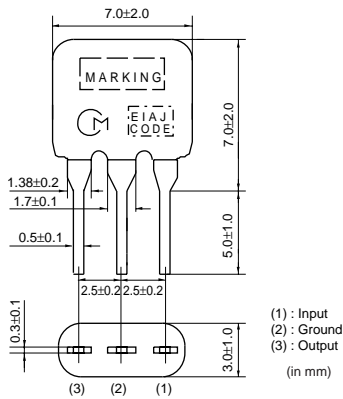

SFELF10M7FA0G-B0

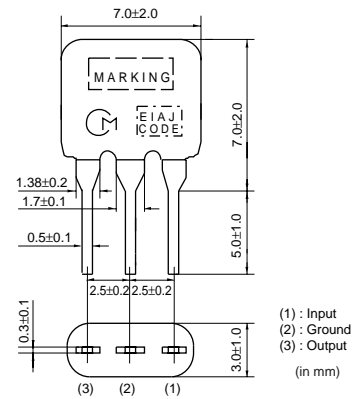

Part Number	Center Frequency (fo) (MHz)	3dB Bandwidth (kHz)	Attenuation (kHz)	Insertion Loss (dB)	Spurious Attenuation (1) (dB)	GDT Bandwidth (kHz)	Input/Output Impedance (ohm)	Spurious Attenuation (2) (dB)
SFELF10M7HA0G-B0	10.700 ±30kHz	180 ±40kHz	520 max.	7.0 max.	40 min.	fo±45 min. [within 0.5µsec.]	330	40 min.
SFELF10M7GA0G-B0	10.700 ±30kHz	230 ±50kHz	600 max.	7.0 max.	40 min.	fo±60 min. [within 0.5µsec.]	330	40 min.
SFELF10M7FA0G-B0	10.700 ±30kHz	280 ±50kHz	650 max.	4.0 ±2.0dB	30 min.	fo±85 min. [within 0.5µsec.]	330	30 min.

Area of Attenuation: [within 20dB]

Area of Spurious Attenuation: [within 9MHz to 12MHz]

Area of Insertion Loss: at minimum loss point

Center frequency (fo) defined by the center of 3dB bandwidth.

For safety purposes, connect the output of filters to the IF amplifier through a D.C. blocking capacitor. Avoid applying a direct current to the output of ceramic filters.

The order quantity should be an integral multiple of the "Minimum Quantity" shown in the package page.

Note • This PDF catalog is downloaded from the website of Murata Manufacturing co., Ltd. Therefore, it's specifications are subject to change or our products in it may be discontinued without advance notice. Please check with our sales representatives or product engineers before ordering.
 • This PDF catalog has only typical specifications because there is no space for detailed specifications. Therefore, please approve our product specifications or transact the approval sheet for product specifications before ordering.

Ceramic Discriminators for FM

● CDSCB Series

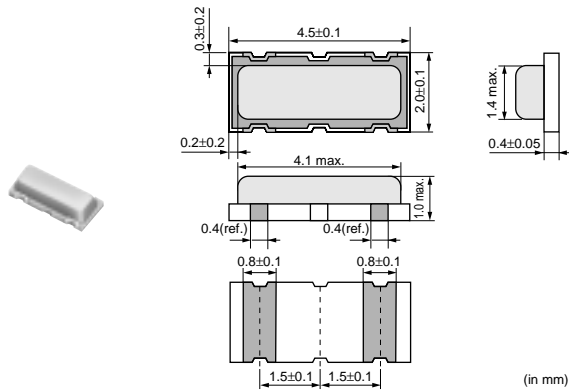

Part Number	Center Frequency (fo) (MHz)	Recovered Audio 3dB BW (kHz)	Recovered Audio Output (mV)	Distortion (%)	S Curve (mV)	IC
CDSCB10M7GA105A-R0	10.700 ±30kHz	220 min.	110 min.	1.5 max.	-	TEA5757HL
CDSCB10M7GA113-R0	10.700 ±30kHz	300 min.	110 min.	1.0 max.	-	TA2154FN
CDSCB10M7GA119-R0	10.700 ±30kHz	500 min.	75 min.	1.0 max.	-	TRF6901
CDSCB10M7GA121-R0	10.700 ±30kHz	390 min.	80 min.	1.0 max.	-	LV23100V
CDSCB10M7GA135-R0	10.700 ±30kHz	155 min.	75 min.	-	-	TH71101
CDSCB10M7GA136-R0	10.700 ±30kHz	140 min.	120 min.	-	-	TH7122
CDSCB10M7GF072-R0	10.700 (fn)	fn±150 min.	130 min.	2.0 max.	-	TA31161
CDSCB10M7GF107S-R0	10.700 (fn)	fn±80 min.	52 min.	3.0 max.	-	TA31272FN
CDSCB10M7GF109-R0	10.700 (fn)	fn±100 min.	170 min.	3.0 max.	-	TK14588V
CDSCB10M7GF123-R0	10.700 (fn)	-	-	-	900 min.	TA31275FN
CDSCB10M7GF123S-R0	10.700 (fn)	-	-	-	900 min.	TA31275FN
CDSCB10M7GF126-R0	10.700 (fn)	-	-	-	400 min.	NJM2295AV

For safety purposes, avoid applying a direct current between the terminals.
The order quantity should be an integral multiple of the "minimum quantity" shown in the package page.

● CDALF Series

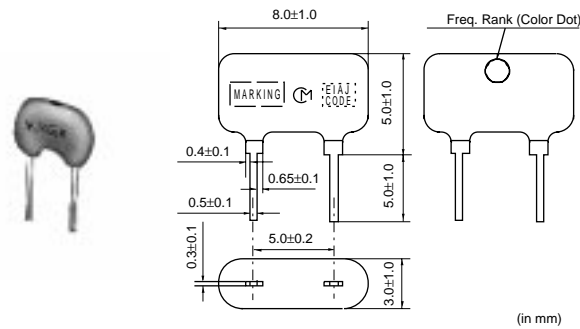

Part Number	Center Frequency (fo) (MHz)	Recovered Audio 3dB BW (kHz)	Recovered Audio Output (mV)	Distortion (%)	IC
CDALF10M7CA005A-B0	10.700 ±30kHz	100 min.	600 min.	6.0 max.	LA7770
CDALF10M7CA040-B0	10.700 ±30kHz	130 min.	40 min.	0.7 max.	TEA5710
CDALF10M7GA016-B0	10.700 ±30kHz	300 min.	within60 to 90mV	0.9 max.	TA8122F
CDALF10M7GA018-B0	10.700 ±30kHz	300 min.	within60 to 90mV	0.9 max.	TA8132N
CDALF10M7GA046-B0	10.700 ±30kHz	330 min.	280 min.	1.0 max.	LA1832
CDALF10M7GA048-B0	10.700 ±30kHz	400 min.	700 min.	1.0 max.	LA1835
CDALF10M7GA092-B0	10.700 ±30kHz	300 min.	60 min.	1.0 max.	TA2132P

(fn) means nominal center frequency (10.700MHz)
For safety purposes, avoid applying a direct current between the terminals.
The order quantity should be an integral multiple of the "minimum quantity" shown in the package page.
CDALF10M7GA018-B0: Color dot is different from standard series.

△Note • This PDF catalog is downloaded from the website of Murata Manufacturing co., ltd. Therefore, it's specifications are subject to change or our products in it may be discontinued without advance notice. Please check with our sales representatives or product engineers before ordering.
• This PDF catalog has only typical specifications because there is no space for detailed specifications. Therefore, please approve our product specifications or transact the approval sheet for product specifications before ordering.

Ceramic Filters (CERAFIL[®]) for TV/VCR

● Chip Type SFSKA/SFSKB Series

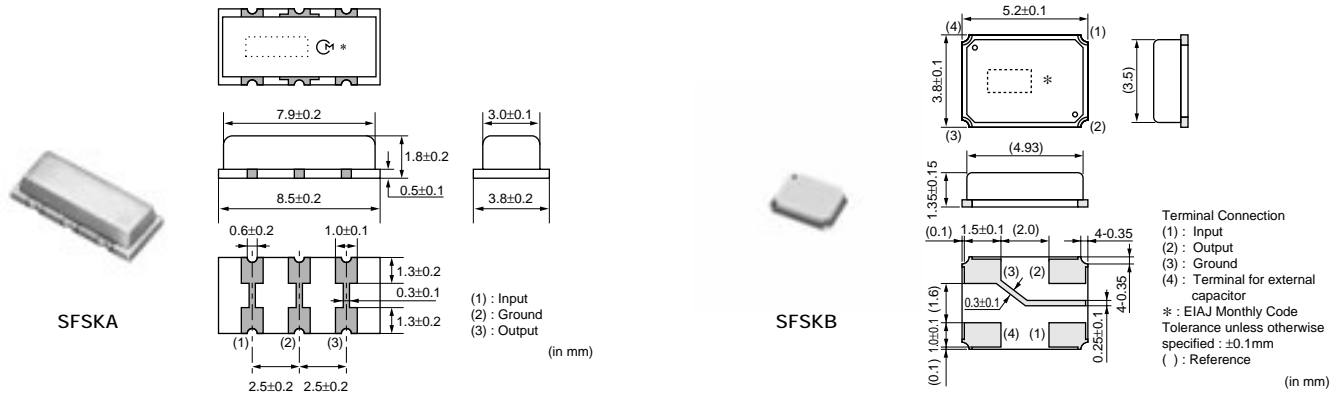

Part Number	Nominal Center Frequency (fn) (MHz)	3dB Bandwidth (kHz)	20dB Bandwidth (kHz)	Insertion Loss (dB)	Spurious Attenuation(1) (dB)	Spurious Attenuation(2) (dB)	Input/Output Impedance (ohm)
SFSKA4M50CF00-R3	4.500	fn±60 min.	600 max.	6.0 max.	20 min. [within 0 to fn]	15 min. [within fn to 7.0MHz]	1000
SFSKA5M50CF00-R3	5.500	fn±60 min.	600 max.	6.0 max.	25 min. [within 0 to fn]	15 min. [within fn to 7.0MHz]	600
SFSKA6M00CF00-R3	6.000	fn±60 min.	600 max.	6.0 max.	25 min. [within 0 to fn]	15 min. [within fn to 7.5MHz]	470
SFSKA6M50CF00-R3	6.500	fn±60 min.	600 max.	6.0 max.	25 min. [within 0 to fn]	15 min. [within fn to 8.5MHz]	470
SFSKB2M30GF00-R1	2.300	fn±75 min.	650 max.	6.0 max.	25 min. [within 1.3 to 1.8MHz]	23 min. [within 2.8 to 3.3MHz]	1000
SFSKB2M80GF00-R1	2.800	fn±75 min.	650 max.	6.0 max.	25 min. [within 1.8 to 2.3MHz]	25 min. [within 3.3 to 3.8MHz]	1000
SFSKB3M20FF00-R1	3.200	fn±75 min.	650 max.	6.0 max.	30 min. [within 2.2 to 2.8MHz]	30 min. [within 3.8 to 4.2MHz]	1000
SFSKB3M80GF00-R1	3.800	fn±75 min.	650 max.	6.0 max.	30 min. [within 2.8 to 3.2MHz]	30 min. [within 4.3 to 4.8MHz]	1000
SFSKB4M30GF00-R1	4.300	fn±75 min.	650 max.	6.0 max.	30 min. [within 3.3 to 3.8MHz]	30 min. [within 4.8 to 5.3MHz]	1000
SFSKB4M80GF00-R1	4.800	fn±75 min.	650 max.	6.0 max.	30 min. [within 3.8 to 4.3MHz]	30 min. [within 5.2 to 5.8MHz]	1000
SFSKB5M20GF00-R1	5.200	fn±75 min.	650 max.	6.0 max.	30 min. [within 4.2 to 4.8MHz]	30 min. [within 5.7 to 6.2MHz]	1000
SFSKB5M70GF00-R1	5.700	fn±75 min.	650 max.	6.0 max.	30 min. [within 4.7 to 5.2MHz]	30 min. [within 6.2 to 6.7MHz]	1000

Area of Insertion Loss: at minimum loss point

For safety purposes, connect the output of filters to the IF amplifier through a D.C. blocking capacitor. Avoid applying a direct current to the output of ceramic filters. The order quantity should be an integral multiple of the "Minimum Quantity" shown in the package page.

Traps for TV/VCR

Ceramic Traps

● Chip Type TPSKA Series

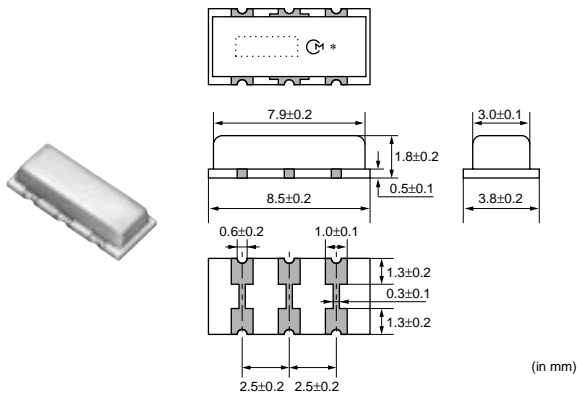

Part Number	Nominal Center Frequency (fn1) (MHz)	Attenuation (at fn1) (dB)	30dB Attenuation BW (fn1) (kHz)
TPSKA4M50B00-R3	4.500	35 min.	50 min.
TPSKA5M50B00-R3	5.500	35 min.	70 min.
TPSKA6M00B00-R3	6.000	35 min.	70 min.
TPSKA6M50B00-R3	6.500	35 min.	70 min.

For safety purposes, connect the output of filters to the IF amplifier through a D.C. blocking capacitor. Avoid applying a direct current to the output of ceramic filters. The order quantity should be an integral multiple of the "Minimum Quantity" shown in the beginning of this catalog.

● Chip Type Double Trap TPWKA Series

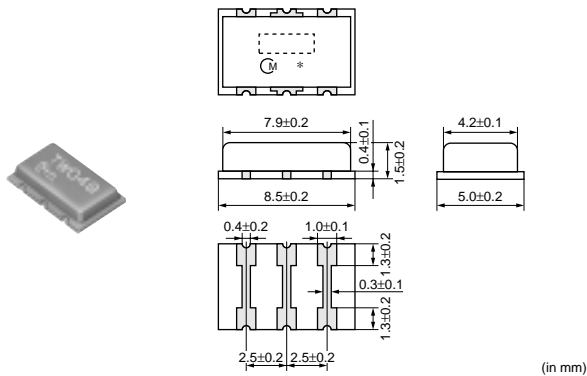

Part Number	Nominal Center Frequency (fn1) (MHz)	Nominal Center Frequency (fn2) (MHz)	Attenuation (at fn1) (dB)	Attenuation (at fn2) (dB)	30dB Attenuation BW (fn1) (kHz)
TPWKA5M50B04-R1	5.500	5.742	30 min.	30 min.	50 min.

For safety purposes, connect the output of filters to the IF amplifier through a D.C. blocking capacitor. Avoid applying a direct current to the output of ceramic filters. The order quantity should be an integral multiple of the "Minimum Quantity" shown in the beginning of this catalog.

△Note • This PDF catalog is downloaded from the website of Murata Manufacturing co., ltd. Therefore, it's specifications are subject to change or our products in it may be discontinued without advance notice. Please check with our sales representatives or product engineers before ordering.
• This PDF catalog has only typical specifications because there is no space for detailed specifications. Therefore, please approve our product specifications or transact the approval sheet for product specifications before ordering.

SAW Traps



SAEEA Series

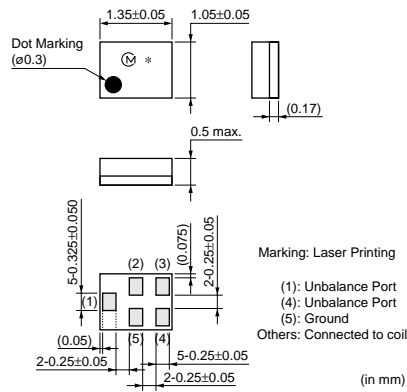

SAEEB Series

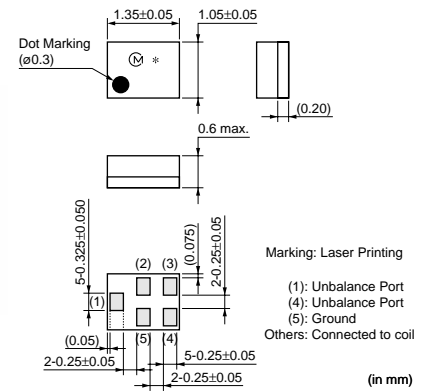

SAEEN Series

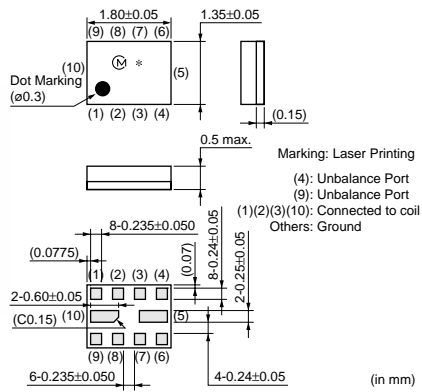

Part Number	Application	Center Frequency (MHz)	Attenuation (MHz)	Insertion Loss (1) (dB max.)	Insertion Loss (2) (dB max.)	Insertion Loss (3) (dB max.)
SAEEA835MBA0F00	ISDB-T	835	830 to 840	1.5 (470MHz to 710MHz)	2.0 (710MHz to 770MHz)	40 (830MHz to 840MHz)
SAEEB897MBB0B00	DVB-H	897.5	880 to 915	2.0 (470MHz to 750MHz)	3.4 (750MHz to 798MHz)	41 (880MHz to 915MHz)
SAEEN832MWA0B00	ISDB-T	832 915	824 to 840	2.1 (470MHz to 710MHz)	3.3 (710MHz to 770MHz)	37 (824MHz to 840MHz)

7

Filters for Communication Equipment

Duplexers
for RF/Local
for IF

● Part Numbering

Duplexer Dielectric Filters (GIGAFIL®)
for RF/Local Dielectric Band Pass Filters (GIGAFIL®)

(Part Number) **DF** **CH3** **1G95** **HDHAA** **-TT1**
① ② ③ ④ ⑤

① Product ID

Product ID	
DF	Microwave Filters (GIGAFIL®)

② Series

Two capital letters and a number express the series name.

③ Nominal Center Frequency

Expressed by four-digit alphanumerics. The unit is hertz (Hz). If the unit is "MHz", it is expressed by three figures plus "M". If the unit is "GHz", a decimal point is expressed by capital letter "G".

④ Individual Specification Code

Expressed by five letters plus a hyphen.

⑤ Packaging

Code	Packaging
T**	Tray
R**	Reel

Packaging varies on each product type. Please contact us for details.

SAW Duplexers for Antennas/Duplexers

(Part Number) **SA** **Y** **ZY** **1G95** **CA0** **B** **00** **R05**
① ② ③ ④ ⑤ ⑥ ⑦ ⑧

① Product ID

② Function

③ Structure/Size

④ Nominal Center Frequency

Expressed by four-digit alphanumerics. The unit is hertz (Hz). If the unit is "MHz", it is expressed by three figures plus "M". If the unit is "GHz", a decimal point is expressed by capital letter "G".

⑤ Character Design

⑥ Board

⑦ Individual Specification

⑧ Packaging

Chip Multilayer LC Filters for RF/Local and IF

(Part Number) **LF** **B** **32** **836M** **SA** **1** **-747**
① ② ③ ④ ⑤ ⑥ ⑦

① Product ID

② Function

③ Dimensions (L×W)

④ Nominal Center Frequency

Expressed by four-digit alphanumerics. The unit is hertz (Hz). If the unit is "MHz", it is expressed by three figures plus "M". If the unit is "GHz", a decimal point is expressed by capital letter "G".



⑤ Series

⑥ Design

⑦ Individual Specification Code

SAW Filters for RF/Local and IF

(Part Number) **SA** **F** **EA** **942M** **FL0** **F** **00** **R12**
① ② ③ ④ ⑤ ⑥ ⑦ ⑧

① Product ID

② Function

③ Structure/Size

④ Nominal Center Frequency

Expressed by four-digit alphanumerics. The unit is hertz (Hz). If the unit is "MHz", it is expressed by three figures plus "M". If the unit is "GHz", a decimal point is expressed by capital letter "G".

⑤ Character Design

⑥ Board

⑦ Individual Specification

⑧ Packaging

Ceramic Filters (CERAFIL®) for IF

(Part Number) **SF** **P** **KA** **455K** **D4A** **-R0**
① ② ③ ④ ⑤ ⑥ ⑦

① Product ID / ② Oscillating/Element

Product ID		Oscillating/Element	
CF	Ceramic Filters	U	4 Elements Area Expansion mode
		W	6 Elements Area Expansion mode
SF	Ceramic Filters	P	4 Elements Area Expansion mode
		E	2 Elements Thickness Expansion mode
		S	2 Elements Thickness Shear mode
		J	4 Elements Thickness Shear mode

③ Structure/Size

④ Nominal Center Frequency

Expressed by four-digit alphanumerics. The unit is hertz (Hz). If the unit is "kHz", it is expressed by three figures plus "K". If the unit is "MHz", a decimal point is expressed by the capital letter "M".

⑤ Product Specification

⑥ Individual Specification

⑦ Packaging

Ceramic Discriminators for IF (MHz)

(Part Number) **CD** **S** **CB** **10M7** **GF** **001** **-R0**
 ① ② ③ ④ ⑤ ⑥ ⑦

- ① Product ID
- ② Oscillation
- ③ Structure/Size
- ④ Nominal Center Frequency

Expressed by four-digit alphanumerics. The unit is in hertz (Hz). If the unit is "MHz", a decimal point is expressed by capital letter "M".

- ⑤ Product Specification
- ⑥ IC
- ⑦ Packaging

Ceramic Discriminators for IF (kHz)

(Part Number) **CD** **B** **LB** **450K** **C** **A** **X** **16** **-B0**
 ① ② ③ ④ ⑤ ⑥ ⑦ ⑧ ⑨

- ① Product ID
- ② Oscillating
- ③ Structure/Size
- ④ Nominal Center Frequency

Expressed by four-digit alphanumerics. The unit is in hertz (Hz). Capital letter "K" following three figures expresses the unit of "kHz".

- ⑤ Detection
- ⑥ Application

Code	Application
A	Standard
L	Application with coil

- ⑦ Element Type

Code	Element Type
X	Low-capacitance
Y	High-capacitance

- ⑧ IC
- ⑨ Packaging

BGS Filter for IF

(Part Number) **MK** **F** **CC** **40M0** **CD0** **P** **00** **R05**
 ① ② ③ ④ ⑤ ⑥ ⑦ ⑧

- ① Product ID
- ② Function
- ③ Structure/Size
- ④ Nominal Center Frequency

Expressed by four-digit alphanumerics. The unit is hertz (Hz). If the unit is "MHz", a decimal point is expressed by capital letter "M".

- ⑤ Product Specification
- ⑥ Piezoelectric Board Material
- ⑦ Individual Specification Code
- ⑧ Packaging

Duplexers

Dielectric Duplexers (GIGAFIL®)

● 800/900MHz



DFYH7815MHDJAA

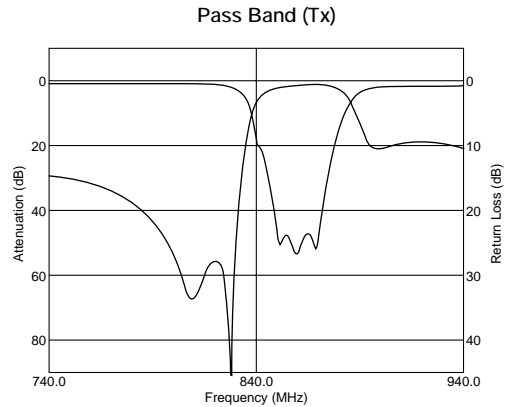
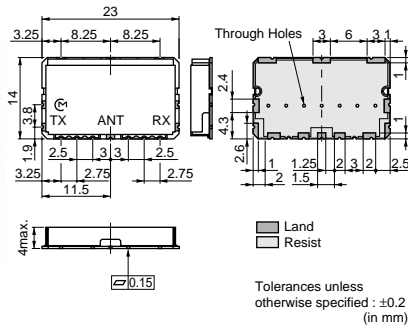

Part Number	Center Frequency (Tx) (MHz)	Bandwidth (Tx) (MHz)	Operation Temperature Range (°C)	Insertion Loss at BW (max.) (dB)	Attenuation (dB min.)	Center Frequency (Rx) (MHz)	Bandwidth (Rx) (MHz)	Operation Temperature Range (°C)	Insertion Loss at BW (max.) (dB)	Attenuation (dB min.)
DFYH7815MHDJAA	815	20	-30 to +85	2.0	40 (850 to 870MHz)	860	20	-30 to +85	4.0	57 (805 to 825MHz)
DFYH7836MHDJAC	881.5	25	-30 to +85	3.0	35 (824 to 849MHz)	836.5	25	-30 to +85	4.0	45 (869 to 894MHz)
DFYH5897MHDJAA	897.5	35	-30 to +85	2.0	15 (935 to 960MHz)	942.5	35	-30 to +85	4.3	20 (905 to 915MHz)
DFYHA897MHFJAA	897.5	35	-35 to +85	3.7	30 (925 to 960MHz)	942.5	35	-35 to +85	4.4	40 (880 to 915MHz)

7

Filters for Communication Equipment

● 1.5GHz-2.5GHz



DFYFB1G54THHAA

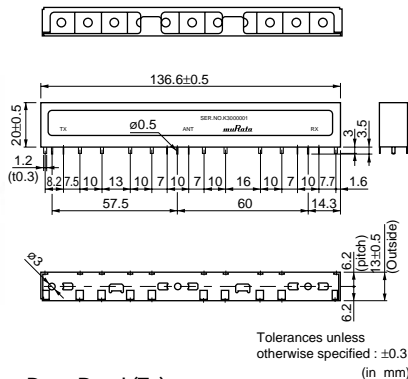

Pass Band (Tx)

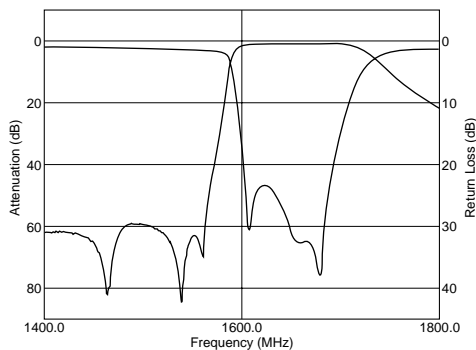

Pass Band (Rx)

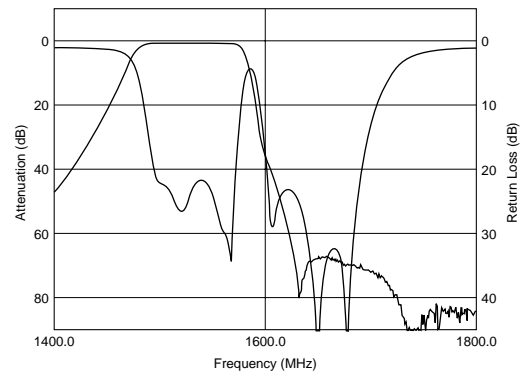

Part Number	Center Frequency (Tx) (MHz)	Bandwidth (Tx) (MHz)	Operation Temperature Range (°C)	Insertion Loss at BW (max.) (dB)	Attenuation (dB min.)	Center Frequency (Rx) (MHz)	Bandwidth (Rx) (MHz)	Operation Temperature Range (°C)	Insertion Loss at BW (max.) (dB)	Attenuation (dB min.)
DFYFB1G54THHAA	1643.5	34	0 to +35	1.0	60 (1525 to 1559MHz)	1542	34	-30 to +85	1.2	65 (1626.5 to 1660.5MHz)
DFYH61G74HDHAA	1747.5	75	-30 to +85	2.3	20 (1805 to 1880MHz)	1842.5	75	-30 to +85	2.7	20 (1710 to 1785MHz)

Continued on the following page.

Note • This PDF catalog is downloaded from the website of Murata Manufacturing co., Ltd. Therefore, its specifications are subject to change or our products in it may be discontinued without advance notice. Please check with our sales representatives or product engineers before ordering.
• This PDF catalog has only typical specifications because there is no space for detailed specifications. Therefore, please approve our product specifications or transact the approval sheet for product specifications before ordering.

Part Number	Center Frequency (MHz)	Bandwidth (MHz)	IL at BW (max.) (dB)	Attenuation (dB min.)	Operation Temperature Range
DFCH22G01HDJAA	2017.5	15	1.8	22 (1899 to 1915MHz)	-40 to +85degree C
DFCH22G44HDHAA	2442	84	1.2	15 (Fo±250MHz)	-35 to +85degree C
DFCH22G45HDHAA	2450	100	1.0	16 (Fo-250MHz)	-35 to +85degree C
DFCH31G54HDJAA	1542	34	3.0	30 (1626.5 to 1660.5MHz)	-35 to +85degree C
DFCH31G64HDJAA	1643.5	34	3.0	30 (1525 to 1559MHz)	-35 to +85degree C
DFCH31G74HDJAA	1747.5	75	2.0	8 (Fo±80MHz)	-35 to +85degree C
DFCH31G84HDJAA	1842.5	75	2.0	8 (Fo±80MHz)	-35 to +85degree C
DFCH31G88HDJAA	1880	60	2.2	15 (Fo±100MHz)	-35 to +85degree C
DFCH31G95HDHAA	1950	60	1.8	45 (1550MHz)	-35 to +85degree C
DFCH31G96HDJAA	1960	60	2.2	15 (Fo±100MHz)	-35 to +85degree C
DFCH32G01HDNAA	2017.5	15	3.0	38 (1920MHz)	-35 to +85degree C
DFCH32G14HDHAA	2140	60	1.3	52 (1325 to 1385MHz)	-35 to +85degree C
DFCH32G44HDHAA	2442	84	2.4	36 (Fo-250MHz)	-35 to +85degree C
DFCH32G45HDHAA	2450	100	2.3	36 (Fo-250MHz)	-35 to +85degree C
DFCH32G59HDHBA	2593	186	1.0	30 (1930 to 1990MHz)	-35 to +85degree C
DFCH41G74HDJAA	1747.5	75	3.6	10 (Fo±57.5MHz)	-35 to +85degree C
DFCH41G84HDJAA	1842.5	75	3.6	10 (Fo±57.5MHz)	-35 to +85degree C
DFCH41G88HDJAA	1880	60	4.5	12 (Fo±50MHz)	-35 to +85degree C
DFCH41G96HDJAA	1960	60	4.5	12 (Fo±50MHz)	-35 to +85degree C
DFCH42G59HDNAA	2590	200	1.5	30(2210MHz)	-40 to +85degree C
DFCH51G73HDNBA	1732.5	45	3.7	44 (1 to 1413MHz)	-35 to +85degree C
DFCH51G76HDNBA	1760	50	3.9	58 (1 to 1443MHz)	-35 to +85degree C
DFCH51G88HDNAA	1880	60	3.8	26 (1930 to 1990MHz)	-35 to +85degree C
DFCH51G95HDNBA	1950	60	3.7	25 (2015 to 2400MHz)	-35 to +85degree C
DFCH52G43HFHAA	2437	50	3.3	28 (2483 to 2570MHz)	-40 to +85degree C
DFCH52G44HFHAA	2442	68	2.0	16.5 (2500 to 2690MHz)	-35 to +85degree C
DFCH52G59HFHAA	2593	234	1.4	40(0.3 to 2300MHz)	-35 to +85degree C
DFCH62G44HFHAA	2442	68	3.5	29 (2500 to 2690MHz)	-35 to +85degree C

for RF/Local

Chip Multilayer LC Filters (BPF)

● LFB15(0402)_CB Series

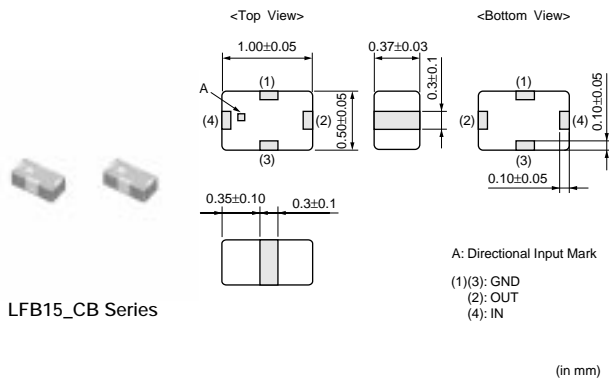

Frequency Characteristics

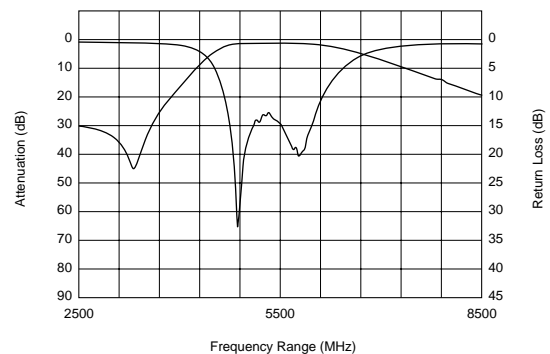

Part Number	Nominal Center Frequency (fo) (MHz)	Bandwidth (BW) (MHz)	Insertion Loss in BW (dB)	Attenuation (Absolute Value) I) (dB)	Attenuation (Absolute Value) II) (dB)	Application
LFB155G37CB1C032	5375	fo±475	1.5 max. (at 25°C)	10 min. at 3800MHz	5 min. at 7500MHz	WLAN/BT
LFB155G50CB1B948	5500	fo±350	1.1 max. (at 25°C)	9.5 min. at 4000MHz	4.5 min. at 7500MHz	WLAN/BT

△Note • This PDF catalog is downloaded from the website of Murata Manufacturing co., Ltd. Therefore, its specifications are subject to change or our products in it may be discontinued without advance notice. Please check with our sales representatives or product engineers before ordering.
 • This PDF catalog has only typical specifications because there is no space for detailed specifications. Therefore, please approve our product specifications or transact the approval sheet for product specifications before ordering.

● LFB18(0603)/21(0805)/2H(1008)/31(1206)_SG Series



LFB18_SG Series

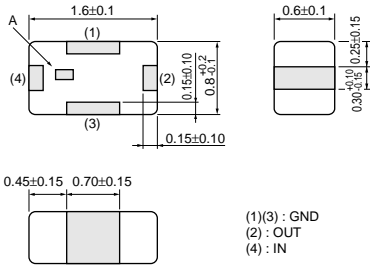

A : Directional Input Mark
All the technical data and information contained herein are subject to change without prior notice. (in mm)

Frequency Characteristics

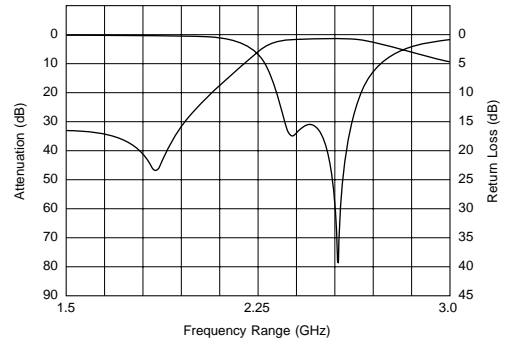

LFB21_SG Series

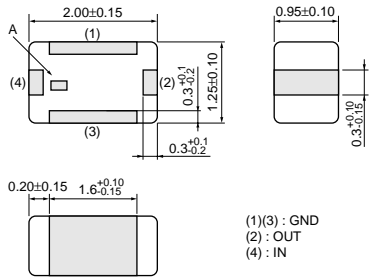

A : Directional Input Mark
All the technical data and information contained herein are subject to change without prior notice. (in mm)

Frequency Characteristics

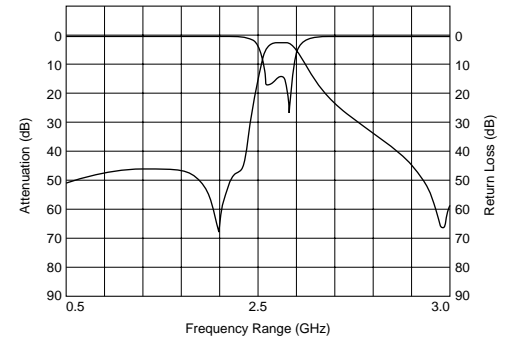

7



LFB2H_SG6 Series

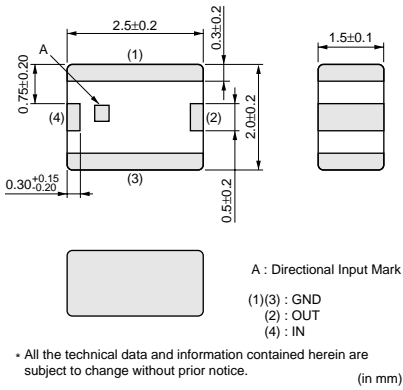

Frequency Characteristics

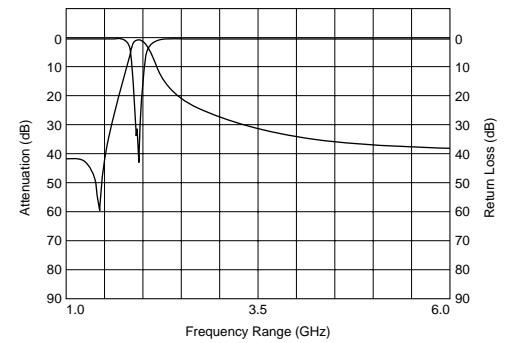

LFB2H_SG7 Series

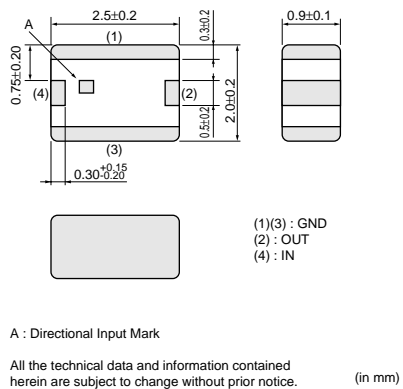

The Characteristics of Spurious

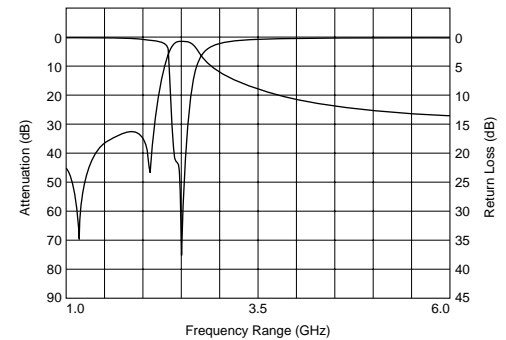

Continued on the following page.

Continued from the preceding page.



LFB31_SG1 Series

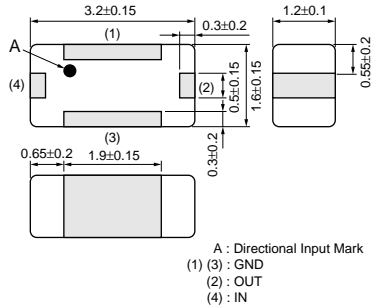

All the technical data and information contained herein are subject to change without prior notice. (in mm)

Frequency Characteristics

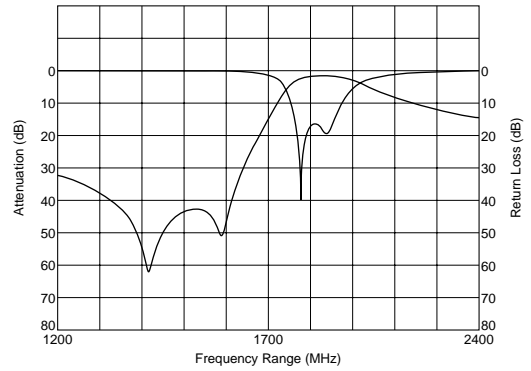

LFB31_SG2 Series

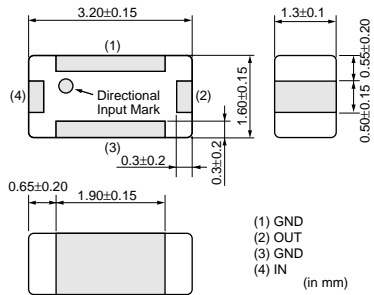

All the technical data and information contained herein are subject to change without prior notice. (in mm)

Frequency Characteristics

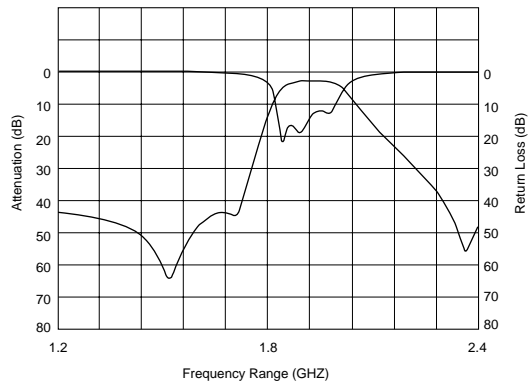

LFB31_SG3 Series

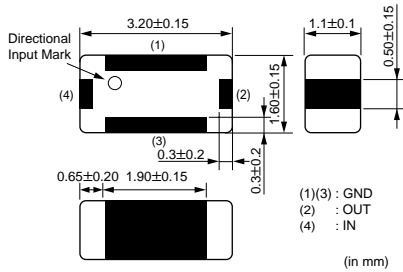

All the technical and information contained herein are subject to change without prior notice. (in mm)

Frequency Characteristics

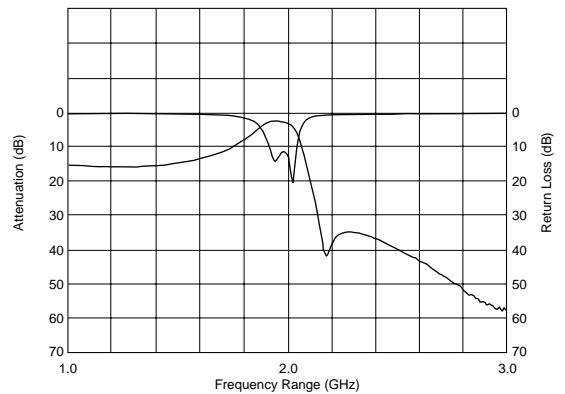

LFB31_SG7 Series

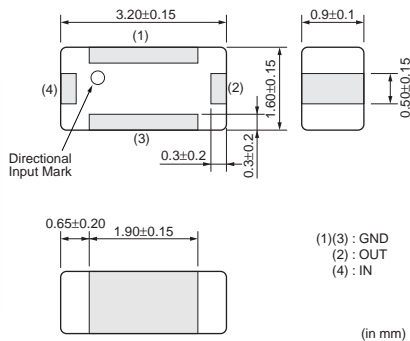

All the technical data and information contained herein are subject to change without prior notice. (in mm)

Frequency Characteristics

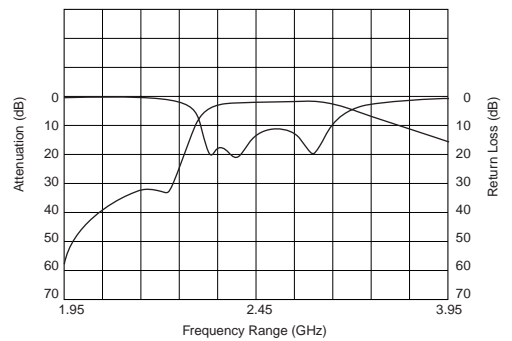

Note • This PDF catalog is downloaded from the website of Murata Manufacturing co., ltd. Therefore, it's specifications are subject to change or our products in it may be discontinued without advance notice. Please check with our sales representatives or product engineers before ordering.
• This PDF catalog has only typical specifications because there is no space for detailed specifications. Therefore, please approve our product specifications or transact the approval sheet for product specifications before ordering.

Part Number	Nominal Center Frequency (fo) (MHz)	Bandwidth (BW) (MHz)	Insertion Loss in BW (dB)	Attenuation (Absolute Value) I (dB)	Attenuation (Absolute Value) II (dB)	Application
LFB182G45SG9A213	2450	fo±50	2.2 max. (at 25°C)	24 min. at 880~960MHz	20 min. at 1710~1990MHz	WLAN/BT
LFB182G45SG9A246	2450	fo±50	2.2 max. (at 25°C)	24.5 min. at 880~960MHz	12.5 min. at 1710~1990MHz	WLAN/BT
LFB182G45SG9A272	2450	fo±50	1.8 max. (at 25°C)	25 min. at 880~1000MHz	22.5 min. at 1200~1300MHz	WLAN/BT
LFB182G60SGHB972	2600	fo±100.0	1.9 max. (at 25°C)	29.5 min. at 806~849MHz	25 min. at 1850~1910MHz	WIMAX
LFB182G60SGHC149	2600	fo±100.0	2.2 max. (at 25°C)	29.5 min. at 806~849MHz	30 min. at 1850~1910MHz	WIMAX
LFB183G60SGJC019	3500	fo±200	1.8 max. (at 25°C)	25.5 min. at 806~849MHz	21.5 min. at 1850~1910MHz	WIMAX
LFB185G78SGAB713	5787.5	fo±62.5	2.2 max. (at 25°C)	16.5 min. at 4800MHz	23.5 min. at 11450~11700MHz	WLAN/BT
LFB211G90SG8B704	1906.5	fo±13.5	3.0 max. (at 25°C)	20 min. at 1660.5~1686.3MHz	11 min. at 2126.8~2152.6MHz	PHS
LFB212G45SG8A127	2450	fo±50	1.5 max. (at 25°C)	25 min. at 1200~1300MHz	10.0 min. at 2000MHz	WLAN/BT
LFB212G45SG8A143	2450	fo±50	2.7 max. (at 25°C)	20 min. at 880~1710MHz	30 min. at 1710~1990MHz	WLAN/BT
LFB212G45SG8A166	2450	fo±50	1.4 max. (at 25°C)	30 min. at 880~915MHz	30 min. at 1710~1910MHz	WLAN/BT
LFB212G45SG8A192	2450	fo±50	2.6 max. (at 25°C)	40 min. at 880~960MHz	38 min. at 1710~1990MHz	WLAN/BT
LFB212G49SG8B830	2495	fo±195	2.4 max. (at 25°C)	30 min. at 824~960MHz	9 min. at 1710~1990MHz	WIMAX
LFB213G60SG8B831	3600	fo±300	1.5 max. (at 25°C)	32 min. at 824~960MHz	24 min. at 1710~1990MHz	WIMAX
LFB215G12SG8A178	5125	fo±225	1.5 max. (at 25°C)	25 min. at 4200MHz	17 min. at 2x(fo±225)MHz	WLAN/BT
LFB215G12SG8A183	5125	fo±225	1.5 max. (at 25°C)	9.0 min. at 4250MHz	10.0 min. at 5900MHz	WLAN/BT
LFB215G25SG8A144	5250	fo±100.0	1.5 max. (at 25°C)	30 min. at 3450MHz	-	WLAN/BT
LFB215G37SG8A180	5375	fo±475	1.8 max. (at 25°C)	29.5 min. at 500~4000MHz	34.5 min. at 3450MHz	WLAN/BT
LFB215G37SG8A185	5375	fo±475	2.2 max. (at 25°C)	40 min. at 340~1195MHz	21 min. at 2140~3580MHz	WLAN/BT
LFB215G51SG8A132	5512	fo±363	1.9 max. (at 25°C)	30 min. at 500~4000MHz	20 min. at 4600MHz	WLAN/BT
LFB215G78SG8A170	5787.5	fo±62.5	2.2 max. (at 25°C)	35 min. at 3275~3400MHz	37 min. at 2x(fo±62.5)MHz	WLAN/BT
LFB2H1G90SG6A157	1906.5	fo±13.5	1.5 max. (at 25°C)	14 min. at 1687MHz	6 min. at 2126MHz	PHS
LFB2H2G45SG7A134	2450	fo±50	1.7 max. (at 25°C)	25 min. at 1750MHz	25 min. at 2100MHz	WLAN/BT
LFB2H2G45SG7A158	2450	fo±50	1.2 max. (at 25°C)	30 min. at 880~915MHz	30 min. at 1710~1785MHz	WLAN/BT
LFB2H2G45SG7A159	2450	fo±50	2.1 max. (at 25°C)	45 min. at 880~915MHz	48 min. at 1710~1990MHz	WLAN/BT
LFB2H2G45SG7B793	2450	fo±50	3.5 max. (at 25°C)	42 min. at 869~915MHz	45 min. at 1710~1785MHz	WLAN/BT
LFB2H2G45SG7C093	2450	fo±50	2.1 max. (at 25°C)	45 min. at 824~915MHz	48 min. at 1710~1990MHz	WLAN/BT

Continued on the following page.

Note • This PDF catalog is downloaded from the website of Murata Manufacturing co., Ltd. Therefore, it's specifications are subject to change or our products in it may be discontinued without advance notice. Please check with our sales representatives or product engineers before ordering.
 • This PDF catalog has only typical specifications because there is no space for detailed specifications. Therefore, please approve our product specifications or transact the approval sheet for product specifications before ordering.

Continued from the preceding page.

Part Number	Nominal Center Frequency (fo) (MHz)	Bandwidth (BW) (MHz)	Insertion Loss in BW (dB)	Attenuation (Absolute Value) I (dB)	Attenuation (Absolute Value) II (dB)	Application
LFB2H2G45SGDB865	2450	fo±50	3.4 max. (at 25°C)	45 min. at 880~915MHz	40 min. at 1710~1785MHz	WLAN/BT
LFB2H2G45SGFB914	2450	fo±50	2.3 max. (at 25°C)	44 min. at 824~960MHz	40 min. at 1710~1785MHz	WLAN/BT
LFB2H2G54SG7B881	2545	fo±145	2 max. (at 25°C)	39.5 min. at 1910MHz	39.5 min. at 1990MHz	WIMAX
LFB2H2G59SG7B858	2590	fo±100	2.1 max. (at 25°C)	40 min. at 824~915MHz	30 min. at 2110~2170MHz	WIMAX
LFB2H5G78SG7A175	5787.5	fo±62.5	2.5 max. (at 25°C)	51.5 min. at 902~928MHz	41 min. at 3919~4044MHz	WLAN/BT
LFB311G90SG1-799	1906.5	fo +24.5/-13.5MHz	2.5 max. (at 25°C)	40 min. at 1397.05~1422.85MHz	35 min. at 1645.5~1671.3MHz	PHS
LFB311G90SG2-797	1906.5	fo±13.5	2.7 max. (at 25°C)	40 min. at 1427~1454MHz	35 min. at 1660~1687MHz	PHS
LFB311G95SG3A564	1950	fo±30	3.5 max. (at 25°C)	20 min. at 2110~2170MHz	25 min. at 2490~2550MHz	UMTS(Band1)
LFB312G45SG2A509	2450	fo±50	2 max. (at 25°C)	38 min. at 902~928MHz	15 min. at 2100~2200MHz	WLAN/BT
LFB312G45SG7A572	2450	fo±50	2.5 max. (at 25°C)	37 min. at 902~928MHz	20 min. at 2100~2200MHz	WLAN/BT

● LFB31_SP Series (1206)

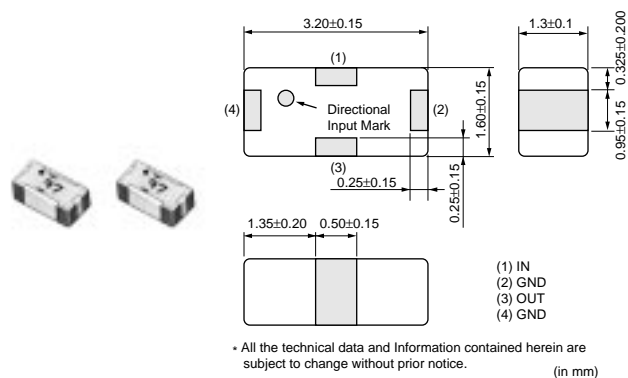

Frequency Characteristics

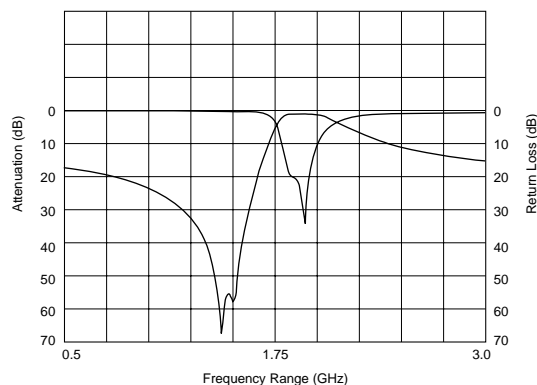

Part Number	Nominal Center Frequency (fo) (MHz)	Bandwidth (BW) (MHz)	Insertion Loss in BW (dB)	Attenuation (Absolute Value) I (dB)	Attenuation (Absolute Value) II (dB)	Application
LFB311G90SP1-798	1906.5	fo±13.5	1.0 max. (at 25°C)	38 min. at 1405~1440MHz	12.0 min. at 1649~1680MHz	PHS
LFB312G45SP1A502	2450	fo±50	1.2 max. (at 25°C)	20 min. at 902~928MHz	35 min. at 1500~1550MHz	WLAN/BT

for RF/Local

Chip Multilayer LC Filters (LPF)

● LFL15_TC (0402) /LFL18_TC (0603) /LFL21_TC (0805) Series



LFL15_TC Series

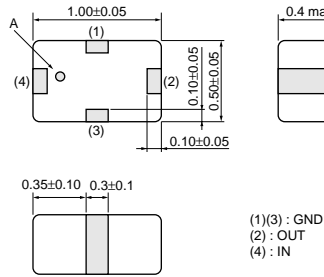

A : Directional Input Mark

All the technical data and information contained herein are subject to change without prior notice. (in mm)

Frequency Characteristics

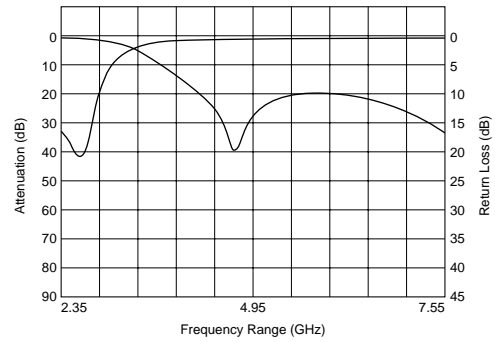

LFL18_TC1 Series

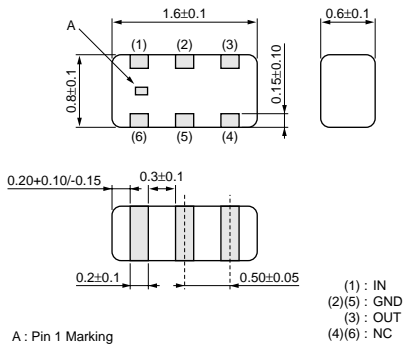

A : Pin 1 Marking

All the technical data and information contained herein are subject to change without prior notice. (in mm)

Frequency Characteristics

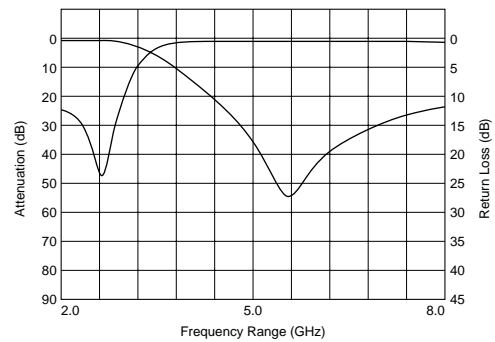

LFL21_TC Series

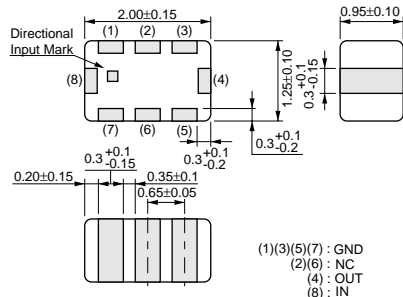

Terminal of "NC" should be fixed to no connected pattern.

* All the technical data and information contained herein are subject to change without prior notice. (in mm)

Frequency Characteristics

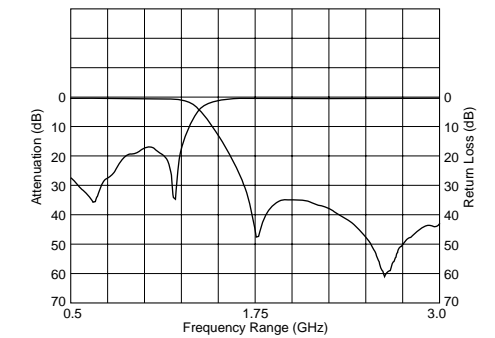

Filters for Communication Equipment

7

Part Number	Nominal Center Frequency (fo) (MHz)	Bandwidth (BW) (MHz)	Insertion Loss in BW (dB)	Attenuation (Absolute Value) I (dB)	Attenuation (Absolute Value) II (dB)	Application
LFL15620MTC1C037	620	fo±150	0.4 max. (at 25°C)	28 min. at 1920~1980MHz	-	CDMA
LFL15869MTC1B787	869.5	fo±45.5	0.50 max. (at 25°C)	18 min. at 2x(fo±45.5)MHz	17 min. at 3x(fo±45.5)MHz	GSM850/900
LFL151G81TC1B786	1810	fo±100	0.60 max. (at 25°C)	23 min. at 3420~3570MHz	21 min. at 3700~3820MHz	GSM1800/1900
LFL152G45TC1A219	2450	fo±50	0.45 max. (at 25°C)	21 min. at 2x(fo±50.0)MHz	21 min. at 3x(fo±50.0)MHz	WLAN/BT
LFL182G45TC1A108	2450	fo±50	0.37 max. (at 25°C)	27 min. at 4800~5000MHz	25 min. at 7200~7500MHz	WLAN/BT
LFL182G45TC1A202	2450	fo±50	0.40 max. (at 25°C)	27 min. at 4800~5000MHz	30 min. at 7200~7500MHz	WLAN/BT

Continued on the following page.

Continued from the preceding page.

Part Number	Nominal Center Frequency (fo) (MHz)	Bandwidth (BW) (MHz)	Insertion Loss in BW (dB)	Attenuation (Absolute Value) I (dB)	Attenuation (Absolute Value) II (dB)	Application
LFL182G45TC3B746	2450	fo±50	0.60 max. (at 25°C)	35 min. at 2x(fo±50)MHz	30 min. at 3x(fo±50)MHz	WLAN/BT
LFL182G50TC1B905	2500	fo±200	0.4 max. (at 25°C)	21 min. at 4600~5400MHz	22 min. at 6900~8100MHz	WIMAX
LFL182G54TC1B838	2545	fo±145	0.4 max. (at 25°C)	26 min. at 4800~5390MHz	23 min. at 7200~8085MHz	WIMAX
LFL183G55TC2B908	3550	fo±250	0.45 max. (at 25°C)	17 min. at 6600~7600MHz	20 min. at 9900~11400MHz	WIMAX
LFL21902MTC1A018	902.5	fo±12.5	0.6 max. (at 25°C)	30 min. at 2x(fo±12.5)MHz	30 min. at 3x(fo±12.5)MHz	GSM
LFL211G90TC1A008	1907.5	fo±12.5	0.47 max. (at 25°C)	30 min. at 2x(fo±12.5)MHz	25 min. at 3x(fo±12.5)MHz	PHS
LFL211G92TC1A060	1920	fo±70	0.6 max. (at 25°C)	24 min. at 3335~3700MHz	30 min. at 3700~3820MHz	UMTS(Band1)
LFL212G45TC1A007	2450	fo±50	0.50 max. (at 25°C)	27 min. at 2x(fo±50.0)MHz	30 min. at 3x(fo±50.0)MHz	WLAN/BT
LFL215G25TC1A156	5250	fo±100.0	0.70 max. (at 25°C)	24 min. at 2x(fo±100)MHz	19 min. at 3x(fo±100)MHz	WLAN/BT
LFL215G37TC1A210	5375	fo±475	0.70 max. (at 25°C)	30 min. at 2x(fo±475)MHz	20 min. at 3x(fo±475)MHz	WLAN/BT
LFL215G51TC1A149	5512	fo±363	0.70 max. (at 25°C)	30 min. at 2x(fo±363)MHz	20 min. at 3x(fo±363)MHz	WLAN/BT
LFL215G78TC1A155	5787.5	fo±62.5	0.70 max. (at 25°C)	30 min. at 2x(fo±62.5)MHz	20 min. at 3x(fo±62.5)MHz	WLAN/BT

for RF/Local

Chip Multilayer LC Filters (Balanced Filters)

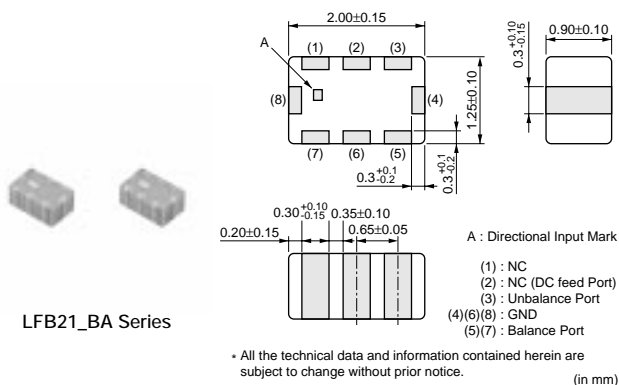

Part Number	Nominal Center Frequency (fo) (MHz)	Bandwidth (BW) (MHz)	Insertion Loss in BW (dB)	Balance Impedance (Differential) (Nom.) (ohm)	Unbalance Impedance (Nom.) (ohm)	Application
LFB212G45BA1A220	2450.00	fo±50.00	3.5 max. (at 25°C)	34.2 -j95.0ohm (Differential) Source Impedance	50	WLAN/BT
LFB212G45BA1A234	2450.00	fo±50.00	3.5 max. (at 25°C)	50	50	WLAN/BT
LFB212G45BA1B759	2450.00	fo±50.00	3.5 max. (at 25°C)	100	50	WLAN/BT
LFB212G45BA1B763	2450.00	fo±50.00	3.5 max. (at 25°C)	50 +j50ohm (Differential) Source Impedance	50	WLAN/BT
LFB212G45BA1C057	2450	fo±50	2.8 max. (at 25°C)	Conjugate match to CSR BC4-ROM	50	WLAN/BT

Continued on the following page. ↗

△Note • This PDF catalog is downloaded from the website of Murata Manufacturing co., ltd. Therefore, it's specifications are subject to change or our products in it may be discontinued without advance notice. Please check with our sales representatives or product engineers before ordering.
• This PDF catalog has only typical specifications because there is no space for detailed specifications. Therefore, please approve our product specifications or transact the approval sheet for product specifications before ordering.

Continued from the preceding page.

Part Number	Nominal Center Frequency (fo) (MHz)	Bandwidth (BW) (MHz)	Insertion Loss in BW (dB)	Balance Impedance (Differential) (Nom.) (ohm)	Unbalance Impedance (Nom.) (ohm)	Application
LFB213G55BA1B974	3500	fo±250	3.2 max. (at 25°C)	100	50	WIMAX
LFB215G37BA1A233	5375.00	fo±475.00	2.8 max. (at 25°C)	100	50	WLAN/BT
LFB2H2G44BB5B754	2441.75	fo±41.75	3.3 max. (at 25°C)	120	50	WLAN/BT
LFB2H2G45BB1A221	2450	fo±50	3.0 max. (at 25°C)	75	50	WLAN/BT
LFB2H2G45BB1A243	2450	fo±50	3.0 max. (at 25°C)	100	50	WLAN/BT
LFB2H2G60BB1B973	2600	fo±100	3.3 max. (at 25°C)	100	50	WIMAX
LFB2H2G60BB1C106	2600	fo±100	3.3 max. (at 25°C)	50	50	WIMAX

for RF/Local

SAW Filters

SAFEA Series

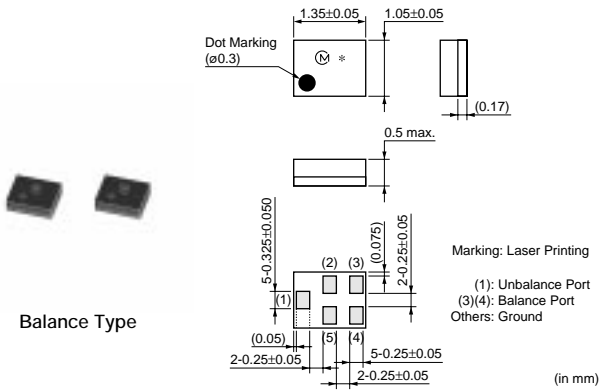

SAFEB Series

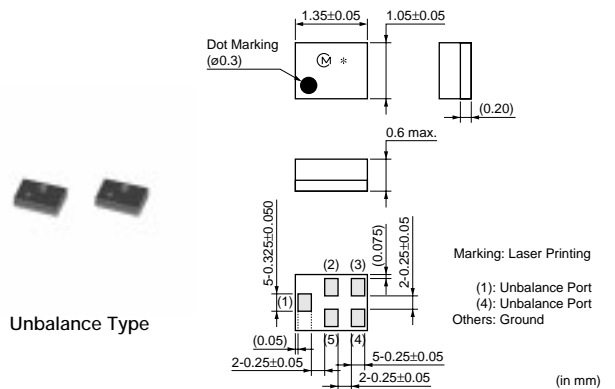
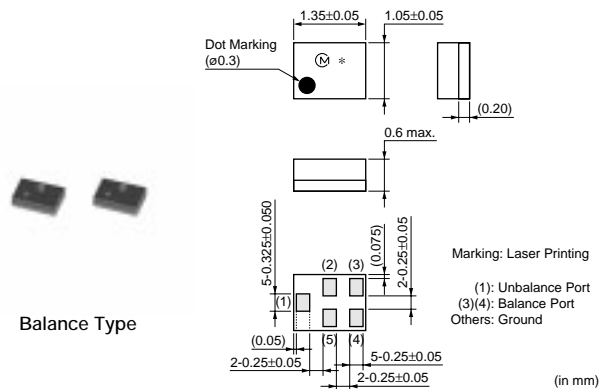

Continued on the following page. ↗

● SAWEN Series

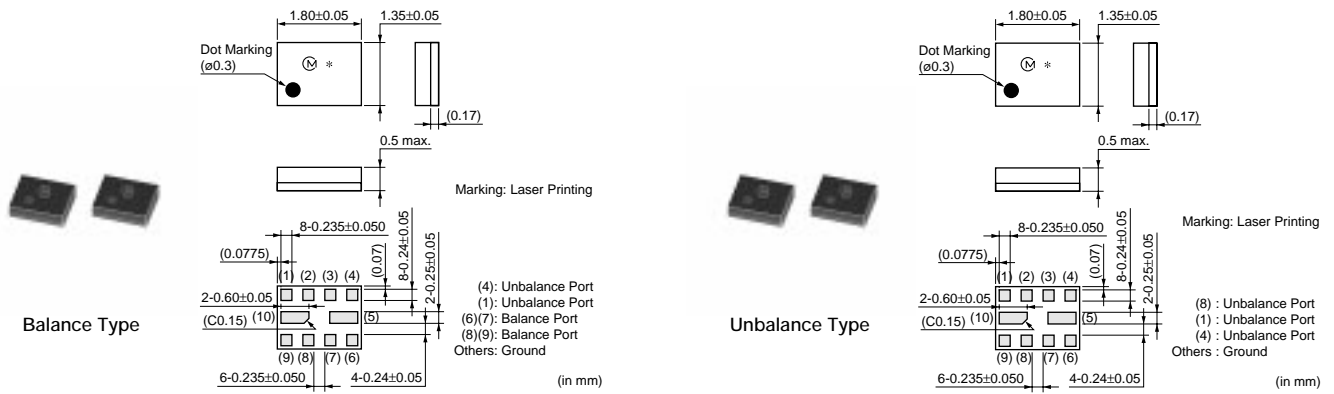

Part Number	Application	Center Frequency (MHz)	Insertion Loss (dB max.)	Ripple (dB max.)	VSWR	Input Impedance	Output Impedance
SAFEB1G57KE0F00	GPS	1575.5	1.3 (1573.92MHz to 1576.92MHz)	0.6 (1573.92MHz to 1576.92MHz)	1.7 (1573.92MHz to 1576.92MHz)	50Ω	50Ω
SAFEB1G57FM0F00	GPS	1575.42	2.3 (1574.22MHz to 1576.62MHz)	0.6 (1574.22MHz to 1576.62MHz)	1.5 (1574.22MHz to 1576.62MHz)	50Ω	100Ω (Balance)
SAFEB1G57KB0F00	GPS	1575.42	0.8 (1574.22MHz to 1576.62MHz)	0.5 (1574.22MHz to 1576.62MHz)	2.0 (1574.22MHz to 1576.62MHz)	50Ω	50Ω
SAFEA881MFL0F00	GSM850	881.5	1.9 (869MHz to 894MHz)	1.0 (869MHz to 894MHz)	1.7 (869MHz to 894MHz)	50Ω	150Ω//82nH (Balance)
SAFEA942MFL0F00	GSM900	942.5	2.3 (925MHz to 960MHz)	1.4 (925MHz to 960MHz)	2.0 (925MHz to 960MHz)	50Ω	150Ω//82nH (Balance)
SAFEA1G84FA0F00	GSM1800	1842.5	2.2 (1805MHz to 1880MHz)	1.5 (1805MHz to 1880MHz)	2.1 (1805MHz to 1880MHz)	50Ω	150Ω//18nH (Balance)
SAFEA1G96FA0F00	GSM1900	1960	2.6 (1930MHz to 1990MHz)	1.7 (1930MHz to 1990MHz)	2.2 (1930MHz to 1990MHz)	50Ω	150Ω//27nH (Balance)
SAWEN881MCN0F00(881.5)	GSM850/900	881.5	2.0 (869MHz to 894MHz)	1.1 (869MHz to 894MHz)	2.0 (869MHz to 894MHz)	50Ω	150Ω//82nH (Balance)
SAWEN881MCN0F00(942.5)	GSM850/900	942.5	2.4 (925MHz to 960MHz)	1.5 (925MHz to 960MHz)	2.1 (925MHz to 960MHz)	50Ω	150Ω//82nH (Balance)
SAWEN881MCM2F00(881.5)	GSM850/1900	881.5	2.0 (869MHz to 894MHz)	1.1 (869MHz to 894MHz)	2.0 (869MHz to 894MHz)	50Ω	150Ω//82nH (Balance)
SAWEN881MCM2F00(1960)	GSM850/1900	1960	2.6 (1930MHz to 1990MHz)	1.8 (1930MHz to 1990MHz)	2.2 (1930MHz to 1990MHz)	50Ω	150Ω//22nH (Balance)
SAWEN942MCN0F00(942.5)	GSM900/1800	942.5	2.3 (925MHz to 960MHz)	1.5 (925MHz to 960MHz)	2.0 (925MHz to 960MHz)	50Ω	150Ω//82nH (Balance)
SAWEN942MCN0F00(1842.5)	GSM900/1800	1842.5	2.5 (1805MHz to 1880MHz)	1.5 (1805MHz to 1880MHz)	2.3 (1805MHz to 1880MHz)	50Ω	150Ω//15nH (Balance)
SAWEN1G84CN0F00(1842.5)	GSM1800/1900	1842.5	2.5 (1805MHz to 1880MHz)	1.8 (1805MHz to 1880MHz)	2.2 (1805MHz to 1880MHz)	50Ω	150Ω//15nH (Balance)
SAWEN1G84CN0F00(1960)	GSM1800/1900	1960	2.6 (1930MHz to 1990MHz)	1.8 (1930MHz to 1990MHz)	2.2 (1930MHz to 1990MHz)	50Ω	150Ω//22nH (Balance)
SAFEA859MCL0F00	JCDMA	859	2.9 (843MHz to 875MHz)	2.0 (843MHz to 875MHz)	2.3 (843MHz to 875MHz)	50Ω	100Ω (Balance)
SAFEB911MAL0F00	JCDMA	911.5	2.2 (898MHz to 925MHz)	1.2 (898MHz to 925MHz)	2.0 (898MHz to 925MHz)	50Ω	50Ω
SAWEN827MAA0F00(827)	JCDMA	827	3.0 (824MHz to 830MHz)	1.3 (824MHz to 830MHz)	2.0 (824MHz to 830MHz)	50Ω	50Ω
SAWEN827MAA0F00(911.5)	JCDMA	911.5	2.8 (898MHz to 925MHz)	1.2 (898MHz to 925MHz)	2.0 (898MHz to 925MHz)	50Ω	50Ω//10nH (Balance)
SAFEA1G88KB7F00	CDMA1900	1880	3.8 (1850MHz to 1910MHz) 3.4 (1850.5MHz to 1909.5MHz)	2.7 (1850MHz to 1910MHz) 2.5 (1850.5MHz to 1909.5MHz)	2.0 (1850MHz to 1910MHz)	50Ω	50Ω

Continued on the following page.

△Note • This PDF catalog is downloaded from the website of Murata Manufacturing co., Ltd. Therefore, it's specifications are subject to change or our products in it may be discontinued without advance notice. Please check with our sales representatives or product engineers before ordering.
 • This PDF catalog has only typical specifications because there is no space for detailed specifications. Therefore, please approve our product specifications or transact the approval sheet for product specifications before ordering.

Continued from the preceding page.

Part Number	Application	Center Frequency (MHz)	Insertion Loss (dB max.)	Ripple (dB max.)	VSWR	Input Impedance	Output Impedance
SAFEB1G96AL0F00	CDMA1900	1960	4.0 (1930.48MHz to 1989.52MHz)	2.3 (1930.48MHz to 1989.52MHz)	2.2 (1930.48MHz to 1989.52MHz)	50Ω	50Ω
SAFEB1G96FL0F00	CDMA1900	1960	3.3 (1930MHz to 1990MHz)	1.8 (1930MHz to 1990MHz)	2.4 (1930MHz to 1990MHz)	50Ω	100Ω (Balance)
SAFEB2G14AL0F00	WCDMA	2140	3.5 (2110MHz to 2170MHz)	1.6 (2110MHz to 2170MHz)	2.0 (2110MHz to 2170MHz)	50Ω	50Ω
SAFEB2G14FB0F00	WCDMA	2140	2.5 (2110MHz to 2170MHz)	1.5 (2110MHz to 2170MHz)	1.9 (2110MHz to 2170MHz)	50Ω	100Ω//27nH (Balance)
SAFEB1G95KA0F00	WCDMA	1950	2.9 (1920MHz to 1980MHz)	2.0 (1920MHz to 1980MHz)	2.0 (1920MHz to 1980MHz)	50Ω	50Ω
SAFEB881MFM0F00	CDMA800	881.5	2.2 (869MHz to 894MHz)	1.5 (869MHz to 894MHz)	2.0 (869MHz to 894MHz)	50Ω	100Ω (Balance)
SAFEB836MAL0F00	CDMA800	836.5	2.5 (824MHz to 849MHz)	1.8 (824MHz to 849MHz)	1.9 (824MHz to 849MHz)	50Ω	50Ω
SAFEA2G44AA0F00	Bluetooth	2441.75	2.8 (2400MHz to 2483.5MHz)	1.5 (2400MHz to 2483.5MHz)	2.4 (2400MHz to 2483.5MHz)	50Ω	50Ω
SAFEA2G45AD0F00	WLAN	2450	2.8 (2400MHz to 2500MHz)	1.8 (2400MHz to 2500MHz)	2.4 (2400MHz to 2500MHz)	50Ω//4.3nH (Unbalance)	50Ω//3.0nH (Unbalance)

Ceramic Filters (CERAFIL®)

●SMD Type (kHz)

Type	Applications	General Use											Attenuation (dB) min. Within 455±80 or ±100kHz
		AMPS	PDC	PAGER CORDLESS	TACS CORDLESS	AM	6dB Bandwidth (kHz) min.						
	A	B	C	D	E	F	G	H	J	K	L		
	±17.5	±15	±12.5	±10	±7.5	±6	±4.5	±3	±2	±1.5	±1		
High Selectivity Series (Plastic Case Type)	SFPKA455K□ (4 Elements)	-	-	-	●	●	●	●	●	-	-	-	27 (G to H ; 25)
	CFUKG455K□ (4 Elements)	-	-	-	●	●	●	●	●	-	-	-	27 (G ; 25)
Narrow Bandwidth GDT Flat Type Miniature Series (Plastic Case Type)	CFUKG455K□X (4 Elements)	-	-	-	●	●	●	●	●	-	-	-	27 (G to H ; 25)
GDT Flat Type Miniature Series (Plastic Case Type)	CFUKF455K□ (4 Elements)	●	●	●	●	●	-	-	-	-	-	-	25 (D to E ; 23)
GDT Flat Type High Selectivity SMD Series (Plastic Case Type)	CFWKA450KBFY (6 Elements)	-	●	-	-	-	-	-	-	-	-	-	45
High Selectivity SMD Series (Plastic Case Type)	CFWKA450K□ (6 Elements)	-	●	-	●	●	●	●	-	-	-	-	50

●Lead Type (kHz)

Type	Applications	General Use											Attenuation (dB) min. Within 455±80 or ±100kHz
		AMPS	PDC	PAGER CORDLESS	TACS CORDLESS	AM	6dB Bandwidth (kHz) min.						
	A	B	C	D	E	F	G	H	J	K	L		
	±17.5	±15	±12.5	±10	±7.5	±6	±4.5	±3	±2	±1.5	±1		
High Selectivity Low Profile Series	CFULA455K□ (4 Elements)	-	●	●	●	●	●	●	●	-	-	-	27 (G ; 25) (H, J ; 35)
	CFWLA455K□ (6 Elements)	-	●	●	●	●	●	●	●	●	-	-	35 (H, J ; 60)
High Selectivity Miniature Series	CFULB455K□ (4 Elements)	-	●	●	●	●	●	●	●	●	-	-	27 (G ; 25) (H, J ; 35)
	CFWLB455K□ (6 Elements)	-	●	●	●	●	●	●	●	●	-	-	35 (H, J ; 65)
GDT Flat Type Series	CFULA455K□Y (4 Elements)	-	●	●	●	●	●	●	-	-	-	-	25 (D to F ; 23) (G ; 20)
	CFWLA455K□Y (6 Elements)	●	●	●	●	●	●	●	-	-	-	-	35
GDT Flat Type Miniature Series	CFULB455K□Y (4 Elements)	-	●	●	●	●	●	●	-	-	-	-	25 (D to F ; 23) (G ; 20)
	CFWLB455K□Y (6 Elements)	●	●	●	●	●	●	●	-	-	-	-	35

for IF

Ceramic Filters (kHz, MHz)

● kHz SMD Type SFPKA Series

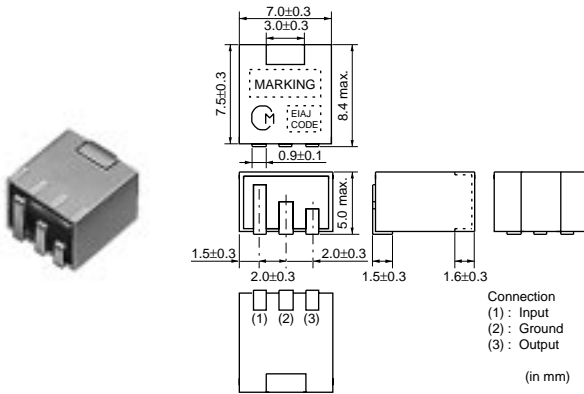

Part Number	Center Frequency (fo) (kHz)	6dB Bandwidth (kHz)	Stop Bandwidth (kHz)	Stop Band Attenuation (dB)	Insertion Loss (dB)	Ripple (dB)	Input/Output Impedance (ohm)
SFPKA455KD4A-R1	455 ±1.5kHz	fn±10.0 min.	fn±20.0 max. [within 40dB]	27 min. [within fn±100kHz]	4.0 max. [at minimum loss point]	2.0 max. [within fn±7kHz]	1500
SFPKA455KE4A-R1	455 ±1.5kHz	fn±7.5 min.	fn±15.0 max. [within 40dB]	27 min. [within fn±100kHz]	6.0 max. [at minimum loss point]	1.5 max. [within fn±5kHz]	1500
SFPKA455KF4A-R1	455 ±1.5kHz	fn±6.0 min.	fn±12.5 max. [within 40dB]	27 min. [within fn±100kHz]	6.0 max. [at minimum loss point]	1.5 max. [within fn±4kHz]	1500
SFPKA455KG1A-R1	455 ±1.0kHz	fn±4.5 min.	fn±10.0 max. [within 40dB]	25 min. [within fn±100kHz]	6.0 max. [at minimum loss point]	1.5 max. [within fn±3kHz]	1500
SFPKA455KH1A-R1	455 ±1.0kHz	fn±3.0 min.	fn±9.0 max. [within 40dB]	35 min. [within fn±100kHz]	6.0 max. [at minimum loss point]	1.5 max. [within fn±2kHz]	2000

Center frequency (fo) defined by the center of 6dB bandwidth.
(fn) means nominal center frequency 455kHz.

For safety purposes, connect the output of filters to the IF amplifier through a D.C. blocking capacitor. Avoid applying a direct current to the output of ceramic filters.
The order quantity should be an integral multiple of the "Minimum Quantity" shown in package page in this catalog.

● kHz SMD Type CFUKG Series

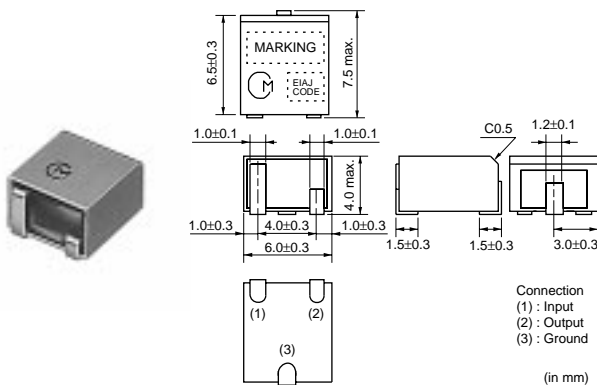

Part Number	Center Frequency (fo) (kHz)	6dB Bandwidth (kHz)	Stop Bandwidth (kHz)	Stop Band Attenuation (dB)	Insertion Loss (dB)	Ripple (dB)	Input/Output Impedance (ohm)
CFUKG455KD4A-R0	455 ±1.5kHz	fn±10.0 min.	fn±20.0 max. [within 40dB]	27 min. [within fn±100kHz]	4.0 max. [at minimum loss point]	2.0 max. [within fn±7kHz]	1500
CFUKG455KE4A-R0	455 ±1.5kHz	fn±7.5 min.	fn±15.0 max. [within 40dB]	27 min. [within fn±100kHz]	6.0 max. [at minimum loss point]	1.5 max. [within fn±5kHz]	1500
CFUKG455KF4A-R0	455 ±1.5kHz	fn±6.0 min.	fn±12.5 max. [within 40dB]	27 min. [within fn±100kHz]	6.0 max. [at minimum loss point]	1.5 max. [within fn±4kHz]	1500

Continued on the following page.

Note • This PDF catalog is downloaded from the website of Murata Manufacturing co., Ltd. Therefore, it's specifications are subject to change or our products in it may be discontinued without advance notice. Please check with our sales representatives or product engineers before ordering.
• This PDF catalog has only typical specifications because there is no space for detailed specifications. Therefore, please approve our product specifications or transact the approval sheet for product specifications before ordering.

Continued from the preceding page.

Part Number	Center Frequency (fo) (kHz)	6dB Bandwidth (kHz)	Stop Bandwidth (kHz)	Stop Band Attenuation (dB)	Insertion Loss (dB)	Ripple (dB)	Input/Output Impedance (ohm)
CFUKG455KG1A-R0	455 ±1.0kHz	fn±4.5 min.	fn±10.0 max. [within 40dB]	25 min. [within fn±100kHz]	6.0 max. [at minimum loss point]	1.5 max. [within fn±3kHz]	1500

Center frequency (fo) defined by the center of 6dB bandwidth.

(fn) means nominal center frequency 455kHz.

For safety purposes, connect the output of filters to the IF amplifier through a D.C. blocking capacitor. Avoid applying a direct current to the output of ceramic filters.

The order quantity should be an integral multiple of the "Minimum Quantity" shown in package page in this catalog.

● kHz SMD Type CFUKG_X Series

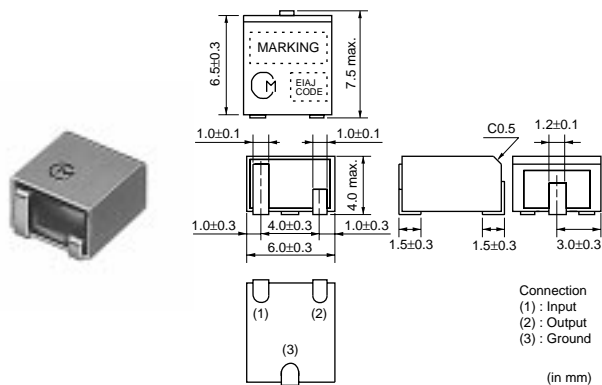

Part Number	Center Frequency (fo) (kHz)	6dB Bandwidth (kHz)	Stop Bandwidth (kHz)	Stop Band Attenuation (dB)	Insertion Loss (dB)	Ripple (dB)	GDT Deviation (μs)	Input/Output Impedance (ohm)
CFUKG455KE4X-R0	455 ±1.5kHz	fn±7.5 min.	fn±17.5 max. [within 40dB]	27 min. [within fn±100kHz]	6.0 max. [at minimum loss point]	1.0 max. [within fn±5kHz]	25.0 max. [within fn±5kHz]	1500
CFUKG455KF4X-R0	455 ±1.5kHz	fn±6.0 min.	fn±15.0 max. [within 40dB]	27 min. [within fn±100kHz]	6.0 max. [at minimum loss point]	1.0 max. [within fn±4kHz]	25.0 max. [within fn±4kHz]	1500
CFUKG455KG1X-R0	455 ±1.0kHz	fn±4.5 min.	fn±12.5 max. [within 40dB]	25 min. [within fn±100kHz]	6.0 max. [at minimum loss point]	1.0 max. [within fn±3kHz]	25.0 max. [within fn±3kHz]	1500
CFUKG455KH1X-R0	455 ±1.0kHz	fn±3.0 min.	fn±10.0 max. [within 40dB]	25 min. [within fn±100kHz]	7.0 max. [at minimum loss point]	1.0 max. [within fn±2kHz]	25.0 max. [within fn±2kHz]	1500

Center frequency (fo) defined by the center of 6dB bandwidth.

(fn) means nominal center frequency 455kHz.

For safety purposes, connect the output of filters to the IF amplifier through a D.C. blocking capacitor. Avoid applying a direct current to the output of ceramic filters.

The order quantity should be an integral multiple of the "Minimum Quantity" shown in package page in this catalog.

● kHz SMD Type CFUKF Series

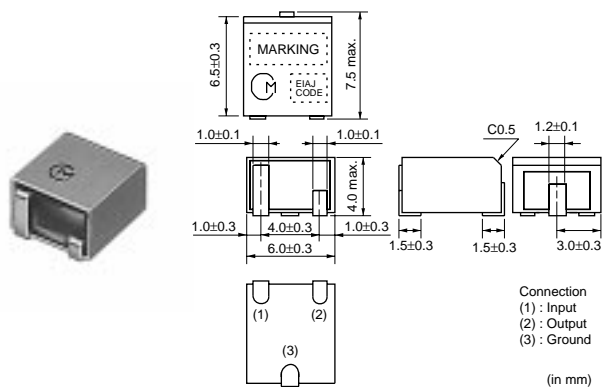

△Note • This PDF catalog is downloaded from the website of Murata Manufacturing co., ltd. Therefore, it's specifications are subject to change or our products in it may be discontinued without advance notice. Please check with our sales representatives or product engineers before ordering.
• This PDF catalog has only typical specifications because there is no space for detailed specifications. Therefore, please approve our product specifications or transact the approval sheet for product specifications before ordering.

Part Number	Center Frequency (fo) (kHz)	6dB Bandwidth (kHz)	Stop Bandwidth (kHz)	Stop Band Attenuation (dB)	Insertion Loss (dB)	Ripple (dB)	GDT Deviation (μs)	Input/Output Impedance (ohm)
CFUKF455KA2X-R0	455 ±2.0kHz	fn±17.5 min.	fn±40.0 max. [within 40dB]	25 min. [within fn±100kHz]	4.0 max. [at minimum loss point]	1.0 max. [within fn±12kHz]	15.0 max. [within fn±12kHz]	1000
CFUKF455KB4X-R0	455 ±1.5kHz	fn±15.0 min.	fn±35.0 max. [within 40dB]	25 min. [within fn±100kHz]	5.0 max. [at minimum loss point]	1.0 max. [within fn±10kHz]	15.0 max. [within fn±10kHz]	1000
CFUKF455KC4X-R0	455 ±1.5kHz	fn±12.5 min.	fn±30.0 max. [within 40dB]	25 min. [within fn±100kHz]	6.0 max. [at minimum loss point]	1.0 max. [within fn±8kHz]	15.0 max. [within fn±8kHz]	1000
CFUKF455KD1X-R0	455 ±1.0kHz	fn±10.0 min.	fn±25.0 max. [within 40dB]	23 min. [within fn±100kHz]	7.0 max. [at minimum loss point]	1.0 max. [within fn±7kHz]	20.0 max. [within fn±7kHz]	1500
CFUKF455KE1X-R0	455 ±1.0kHz	fn±7.5 min.	fn±20.0 max. [within 40dB]	23 min. [within fn±100kHz]	8.0 max. [at minimum loss point]	1.0 max. [within fn±5kHz]	20.0 max. [within fn±5kHz]	1500

Center frequency (fo) defined by the center of 6dB bandwidth.

(fn) means nominal center frequency 455kHz.

For safety purposes, connect the output of filters to the IF amplifier through a D.C. blocking capacitor. Avoid applying a direct current to the output of ceramic filters.

The order quantity should be an integral multiple of the "Minimum Quantity" shown in package page in this catalog.

● kHz SMD Type CFWKA Series

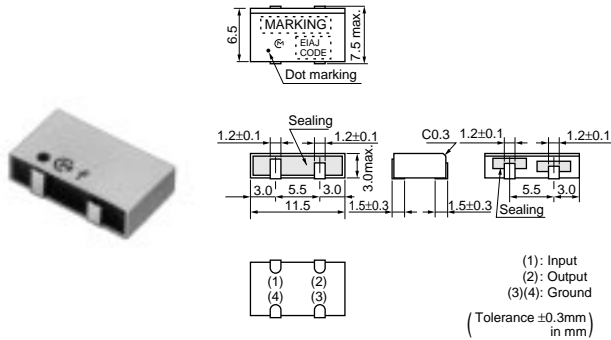

Part Number	Nominal Center Frequency (fn) (kHz)	3dB Bandwidth (kHz)	6dB Bandwidth (kHz)	Stop Bandwidth (kHz)	Stop Band Attenuation (dB)	Stop Band Att. (2) (dB)	Insertion Loss (dB)	Ripple (dB)	Input/Output Impedance (ohm)
CFWKA450K DFA-R0	450.0	-	fn±10.0 min.	fn±20.0 max. [within 50dB]	50 min. [within fn±100kHz]	-	4.0 max. [at minimum loss point]	3.0 max. [within fn±7kHz]	1500
CFWKA450KEFA-R0	450.0	-	fn±7.5 min.	fn±15.0 max. [within 50dB]	50 min. [within fn±100kHz]	-	6.0 max. [at minimum loss point]	3.0 max. [within fn±5kHz]	1500
CFWKA450KEFA001-R0	450.0	fn±6.5 min.	-	fn±15.0 max. [within 50dB]	55 min. [fn±18 to ±33kHz]	50 min. [within fn±100kHz]	4.0 max. [at fn]	3.0 max. [within fn±6.5kHz]	1500
CFWKA450KFFA-R0	450.0	-	fn±6.0 min.	fn±12.5 min. [within 50dB]	50 min. [within fn±100kHz]	-	6.0 max. [at minimum loss point]	3.0 max. [within fn±4kHz]	1500
CFWKA450KGF A-R0	450.0	-	fn±4.5 min.	fn±11.0 max. [within 50dB]	50 min. [within fn±100kHz]	-	6.0 max. [at minimum loss point]	2.0 max. [within fn±3kHz]	1500

For safety purposes, connect the output of filters to the IF amplifier through a D.C. blocking capacitor. Avoid applying a direct current to the output of ceramic filters.

The order quantity should be an integral multiple of the "Minimum Quantity" shown in the beginning of this catalog.

● kHz SMD Type CFWKA_Y Series

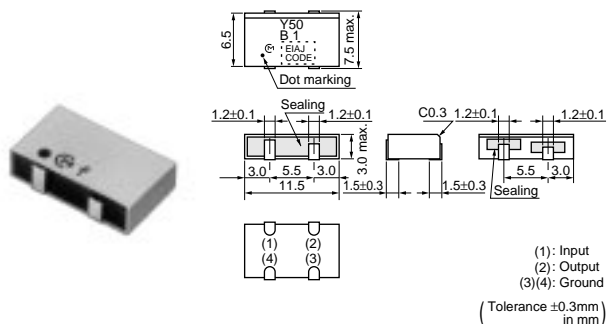

Part Number	Nominal Center Frequency (fn) (kHz)	3dB Bandwidth (kHz)	6dB Bandwidth (kHz)	Stop Bandwidth (kHz)	Stop Band Attenuation (dB)	Insertion Loss (dB)	Spurious Response (dB)	GDT Deviation (μs)	Input/Output Impedance (ohm)
CFWKA450KBFY001-R0	450.0	fn±11.5 min.	fn±13.0 min.	fn±30.0 max. [within 50dB]	45 min. [within fn±100kHz]	4.0 max. [at minimum loss point]	20 min. [within 0.1 to 1.0MHz]	30.0 max. [within fn±10kHz]	1000

For safety purposes, connect the output of filters to the IF amplifier through a D.C. blocking capacitor. Avoid applying a direct current to the output of ceramic filters. The order quantity should be an integral multiple of the "Minimum Quantity" shown in the beginning of this catalog.

● MHz SMD Type SFSCE10M7 Series

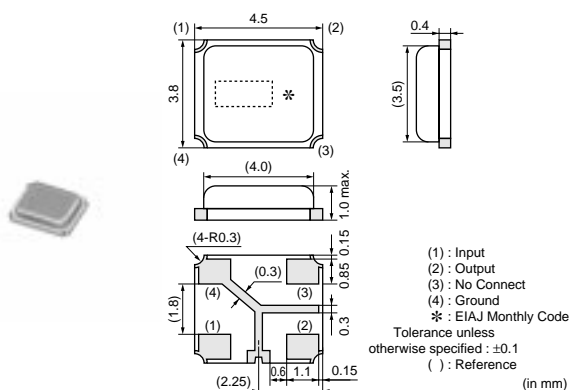

Part Number	Nominal Center Frequency (fn) (MHz)	3dB Bandwidth (kHz)	Stop Bandwidth (MHz)	Insertion Loss (dB)	Ripple (dB)	Spurious Response (dB)	GDT Deviation (μs)	Input/Output Impedance (ohm)
SFSCE10M7WF03-R0	10.700	fn±500.0 min.	2.2 max. (Total) [within 20dB]	6.0 max. [at minimum loss point]	2.0 max. [within 3dB Bandwidth]	30/25 min. [within 5.7MHz to fn / fn to 15.7MHz]	0.6 max. [within fn±400kHz]	470
SFSCE10M7WF04-R0	10.700	fn±400.0 min.	1.8 max. (Total) [within 20dB]	6.0 max. [at minimum loss point]	1.5 max. [within 3dB Bandwidth]	35/25 min. [within 5.7MHz to fn / fn to 15.7MHz]	0.6 max. [within fn±325kHz]	470
SFSCE10M7WF05-R0	10.700	fn±325.0 min.	1.7 max. (Total) [within 20dB]	6.0 max. [at minimum loss point]	1.5 max. [within 3dB Bandwidth]	40/30 min. [within 5.7MHz to fn / fn to 15.7MHz]	0.6 max. [within fn±250kHz]	470

For safety purposes, connect the output of filters to the IF amplifier through a D.C. blocking capacitor. Avoid applying a direct current to the output of ceramic filters. The order quantity should be an integral multiple of the "Minimum Quantity" shown in package page in this catalog.

△Note • This PDF catalog is downloaded from the website of Murata Manufacturing co., ltd. Therefore, it's specifications are subject to change or our products in it may be discontinued without advance notice. Please check with our sales representatives or product engineers before ordering.
 • This PDF catalog has only typical specifications because there is no space for detailed specifications. Therefore, please approve our product specifications or transact the approval sheet for product specifications before ordering.

● Plastic Case General Use CFULA Series

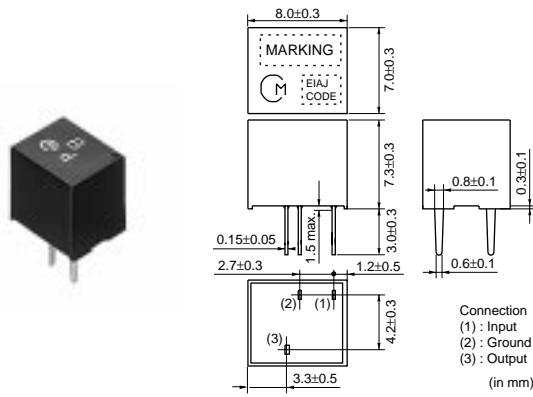

Connection
(1) : Input
(2) : Ground
(3) : Output
(in mm)

Part Number	Center Frequency (fo) (kHz)	6dB Bandwidth (kHz)	Stop Bandwidth (kHz)	Stop Band Attenuation (dB)	Insertion Loss (dB)	Input/Output Impedance (ohm)
CFULA455KB2A-B0	455 ±2.0kHz	fn±15.0 min.	fn±30.0 max. [within 40dB]	27 min. [within fn±100kHz]	4.0 max. [at minimum loss point]	1500
CFULA455KC2A-B0	455 ±2.0kHz	fn±12.5 min.	fn±24.0 max. [within 40dB]	27 min. [within fn±100kHz]	4.0 max. [at minimum loss point]	1500
CFULA455KD4A-B0	455 ±1.5kHz	fn±10.0 min.	fn±20.0 max. [within 40dB]	27 min. [within fn±100kHz]	4.0 max. [at minimum loss point]	1500
CFULA455KE4A-B0	455 ±1.5kHz	fn±7.5 min.	fn±15.0 max. [within 40dB]	27 min. [within fn±100kHz]	6.0 max. [at minimum loss point]	1500
CFULA455KF4A-B0	455 ±1.5kHz	fn±6.0 min.	fn±12.5 max. [within 40dB]	27 min. [within fn±100kHz]	6.0 max. [at minimum loss point]	2000
CFULA455KG1A-B0	455 ±1.0kHz	fn±4.5 min.	fn±10.0 max. [within 40dB]	25 min. [within fn±100kHz]	6.0 max. [at minimum loss point]	2000
CFULA455KH1A-B0	455 ±1.0kHz	fn±3.0 min.	fn±9.0 max. [within 40dB]	35 min. [within fn±100kHz]	6.0 max. [at minimum loss point]	2000

Center frequency (fo) defined by the center of 6dB bandwidth.

(fn) means nominal center frequency 455kHz.

For safety purposes, connect the output of filters to the IF amplifier through a D.C. blocking capacitor. Avoid applying a direct current to the output of ceramic filters.

The order quantity should be an integral multiple of the "Minimum Quantity" shown in package page in this catalog.

● Plastic Case General Use Type CFWLA Series

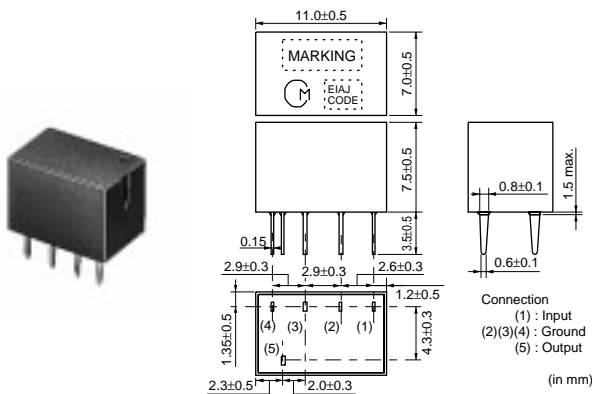

Connection
(1) : Input
(2)(3)(4) : Ground
(5) : Output
(in mm)

Part Number	Nominal Center Frequency (fn) (kHz)	6dB Bandwidth (kHz)	Stop Bandwidth (kHz)	Stop Band Attenuation (dB)	Insertion Loss (dB)	Ripple (dB)	Input/Output Impedance (ohm)
CFWLA455KBFA-B0	455.0	fn±15.0 min.	fn±30.0 max. [within 50dB]	35 min. [within fn±100kHz]	4.0 max. [at minimum loss point]	3.0 max. [within fn±10kHz]	1500
CFWLA455KCFA-B0	455.0	fn±12.5 min.	fn±24.0 max. [within 50dB]	35 min. [within fn±100kHz]	4.0 max. [at minimum loss point]	3.0 max. [within fn±8kHz]	1500
CFWLA455KDFB-B0	455.0	fn±10.0 min.	fn±20.0 max. [within 50dB]	35 min. [within fn±100kHz]	4.0 max. [at minimum loss point]	3.0 max. [within fn±7kHz]	1500

Continued on the following page.

Note • This PDF catalog is downloaded from the website of Murata Manufacturing co., ltd. Therefore, it's specifications are subject to change or our products in it may be discontinued without advance notice. Please check with our sales representatives or product engineers before ordering.
• This PDF catalog has only typical specifications because there is no space for detailed specifications. Therefore, please approve our product specifications or transact the approval sheet for product specifications before ordering.

Continued from the preceding page.

Part Number	Nominal Center Frequency (fn) (kHz)	6dB Bandwidth (kHz)	Stop Bandwidth (kHz)	Stop Band Attenuation (dB)	Insertion Loss (dB)	Ripple (dB)	Input/Output Impedance (ohm)
CFWLA455KEFA-B0	455.0	fn±7.5 min.	fn±15.0 max. [within 50dB]	35 min. [within fn±100kHz]	6.0 max. [at minimum loss point]	3.0 max. [within fn±5kHz]	1500
CFWLA455KFFA-B0	455.0	fn±6.0 min.	fn±12.5 max. [within 50dB]	35 min. [within fn±100kHz]	6.0 max. [at minimum loss point]	3.0 max. [within fn±4kHz]	2000
CFWLA455KGF A-B0	455.0	fn±4.5 min.	fn±10.0 max. [within 50dB]	35 min. [within fn±100kHz]	6.0 max. [at minimum loss point]	2.0 max. [within fn±3kHz]	2000
CFWLA455KHFA-B0	455.0	fn±3.0 min.	fn±9.0 max. [within 50dB]	60 min. [within fn±100kHz]	6.0 max. [at minimum loss point]	2.0 max. [within fn±2kHz]	2000
CFWLA455KJFA-B0	455.0	fn±2.0 min.	fn±7.5 max. [within 50dB]	60 min. [within fn±100kHz]	7.0 max. [at minimum loss point]	2.0 max. [within fn±1.5kHz]	2000

For safety purposes, connect the output of filters to the IF amplifier through a D.C. blocking capacitor. Avoid applying a direct current to the output of ceramic filters. The order quantity should be an integral multiple of the "Minimum Quantity" shown in the beginning of this catalog.

● Plastic Case Miniaturized Type CFULB Series

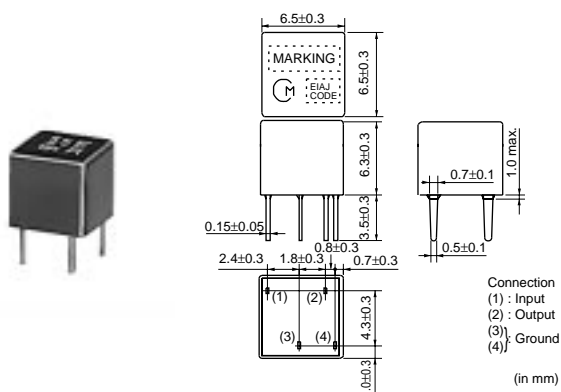

Part Number	Center Frequency (fo) (kHz)	6dB Bandwidth (kHz)	Stop Bandwidth (kHz)	Stop Band Attenuation (dB)	Insertion Loss (dB)	Input/Output Impedance (ohm)
CFULB455KB2A-B0	455 ±2.0kHz	fn±15.0 min.	fn±30.0 max. [within 40dB]	27 min. [within fn±100kHz]	4.0 max. [at minimum loss point]	1500
CFULB455KC2A-B0	455 ±2.0kHz	fn±12.5 min.	fn±24.0 max. [within 40dB]	27 min. [within fn±100kHz]	4.0 max. [at minimum loss point]	1500
CFULB455KD4A-B0	455 ±1.5kHz	fn±10.0 min.	fn±20.0 max. [within 40dB]	27 min. [within fn±100kHz]	4.0 max. [at minimum loss point]	1500
CFULB455KE4A-B0	455 ±1.5kHz	fn±7.5 min.	fn±15.0 max. [within 40dB]	27 min. [within fn±100kHz]	6.0 max. [at minimum loss point]	1500
CFULB455KF4A-B0	455 ±1.5kHz	fn±6.0 min.	fn±12.5 max. [within 40dB]	27 min. [within fn±100kHz]	6.0 max. [at minimum loss point]	2000
CFULB455KG1A-B0	455 ±1.0kHz	fn±4.5 min.	fn±10.0 max. [within 40dB]	25 min. [within fn±100kHz]	6.0 max. [at minimum loss point]	2000
CFULB455KH1A-B0	455 ±1.0kHz	fn±3.0 min.	fn±9.0 max. [within 40dB]	35 min. [within fn±100kHz]	6.0 max. [at minimum loss point]	2000
CFULB455KJ1A-B0	455 ±1.0kHz	fn±2.0 min.	fn±7.5 max. [within 40dB]	35 min. [within fn±100kHz]	6.0 max. [at minimum loss point]	2000

Center frequency (fo) defined by the center of 6dB bandwidth.

(fn) means nominal center frequency 455kHz.

CFULB455K series filters are 4-element ceramic filters and miniature versions of CFULA455K series.

For safety purposes, connect the output of filters to the IF amplifier through a D.C. blocking capacitor. Avoid applying a direct current to the output of ceramic filters.

The order quantity should be an integral multiple of the "Minimum Quantity" shown in package page in this catalog.

△Note • This PDF catalog is downloaded from the website of Murata Manufacturing co., ltd. Therefore, it's specifications are subject to change or our products in it may be discontinued without advance notice. Please check with our sales representatives or product engineers before ordering.
• This PDF catalog has only typical specifications because there is no space for detailed specifications. Therefore, please approve our product specifications or transact the approval sheet for product specifications before ordering.

● Plastic Case Miniaturized CFWLB Series

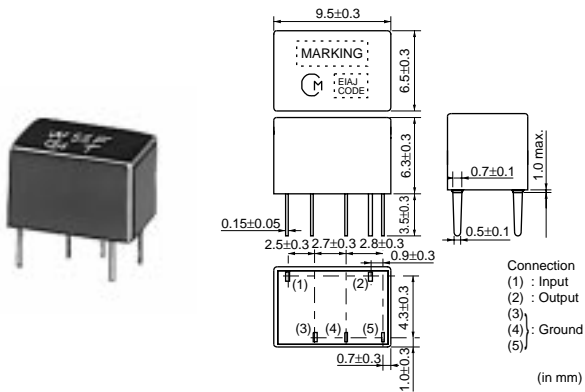

Part Number	Nominal Center Frequency (fn) (kHz)	6dB Bandwidth (kHz)	Stop Bandwidth (kHz)	Stop Band Attenuation (dB)	Insertion Loss (dB)	Input/Output Impedance (ohm)
CFWLB455KBFA-B0	455.0	fn±15.0 min.	fn±30.0 max. [within 50dB]	35 min. [within fn±100kHz]	4.0 max. [at minimum loss point]	1500
CFWLB455KCFA-B0	455.0	fn±12.5 min.	fn±24.0 max. [within 50dB]	35 min. [within fn±100kHz]	4.0 max. [at minimum loss point]	1500
CFWLB455KDFA-B0	455.0	fn±10.0 min.	fn±20.0 max. [within 50dB]	35 min. [within fn±100kHz]	4.0 max. [at minimum loss point]	1500
CFWLB455KEFA-B0	455.0	fn±7.5 min.	fn±15.0 max. [within 50dB]	35 min. [within fn±100kHz]	6.0 max. [at minimum loss point]	1500
CFWLB455KEFA004-B0	455.0	fn±7.5 min.	fn±15.0 max. [within 60dB]	60 min. [within fn±15kHz to 30kHz]	5.0 max. [at fn]	1500
CFWLB455KFFA-B0	455.0	fn±6.0 min.	fn±12.5 max. [within 50dB]	35 min. [within fn±100kHz]	6.0 max. [at minimum loss point]	2000
CFWLB455KGF A-B0	455.0	fn±4.5 min.	fn±10.0 max. [within 50dB]	35 min. [within fn±100kHz]	6.0 max. [at minimum loss point]	2000
CFWLB455KHFA-B0	455.0	fn±3.0 min.	fn±9.0 max. [within 50dB]	55 min. [within fn±100kHz]	6.0 max. [at minimum loss point]	2000
CFWLB455KJFA-B0	455.0	fn±2.0 min.	fn±7.0 max. [within 50dB]	55 min. [within fn±100kHz]	7.0 max. [at minimum loss point]	2000

CFWLB455K series filters are 4-element ceramic filters and miniature versions of CFWLA455K series.

For safety purposes, connect the output of filters to the IF amplifier through a D.C. blocking capacitor. Avoid applying a direct current to the output of ceramic filters.

The order quantity should be an integral multiple of the "Minimum Quantity" shown in package page in this catalog.

● Plastic Case Group Delay Flat Type CFULA_Y Series

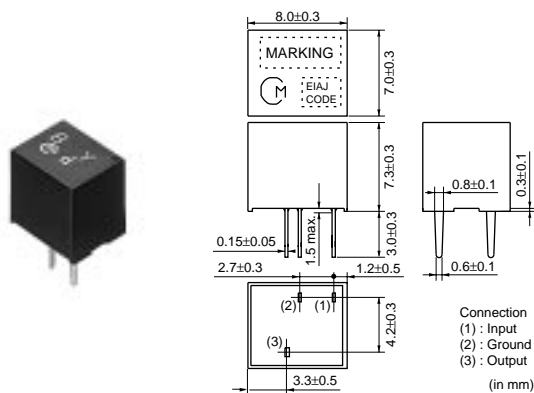

Part Number	Center Frequency (fo) (kHz)	6dB Bandwidth (kHz)	Stop Bandwidth (kHz)	Stop Band Attenuation (dB)	Insertion Loss (dB)	GDT Deviation (μs)	Input/Output Impedance (ohm)
CFULA455KB4Y-B0	455 ±1.5kHz	fn±15.0 min.	fn±35.0 max. [within 40dB]	25 min. [within fn±100kHz]	5.0 max. [at minimum loss point]	15.0 max. [within fn±10kHz]	1500
CFULA455KC4Y-B0	455 ±1.5kHz	fn±12.5 min.	fn±30.0 max. [within 40dB]	25 min. [within fn±100kHz]	6.0 max. [at minimum loss point]	15.0 max. [within fn±8kHz]	1500
CFULA455KD1Y-B0	455 ±1.0kHz	fn±10.0 min.	fn±25.0 max. [within 40dB]	23 min. [within fn±100kHz]	7.0 max. [at minimum loss point]	20.0 max. [within fn±7kHz]	1500
CFULA455KE1Y-B0	455 ±1.0kHz	fn±7.5 min.	fn±20.0 max. [within 40dB]	23 min. [within fn±100kHz]	8.0 max. [at minimum loss point]	20.0 max. [within fn±5kHz]	1500
CFULA455KF1Y-B0	455 ±1.0kHz	fn±6.0 min.	fn±17.5 max. [within 40dB]	23 min. [within fn±100kHz]	9.0 max. [at minimum loss point]	20.0 max. [within fn±4kHz]	2000
CFULA455KG1Y-B0	455 ±1.0kHz	fn±4.5 min.	fn±15.0 max. [within 40dB]	23 min. [within fn±100kHz]	10.0 max. [at minimum loss point]	20.0 max. [within fn±3kHz]	2000

Center frequency (fo) defined by the center of 6dB bandwidth.

(fn) means nominal center frequency 455kHz.

For safety purposes, connect the output of filters to the IF amplifier through a D.C. blocking capacitor. Avoid applying a direct current to the output of ceramic filters.

The order quantity should be an integral multiple of the "Minimum Quantity" shown in package page in this catalog.

● Plastic Case Group Delay Flat Type CFWLA_Y Series

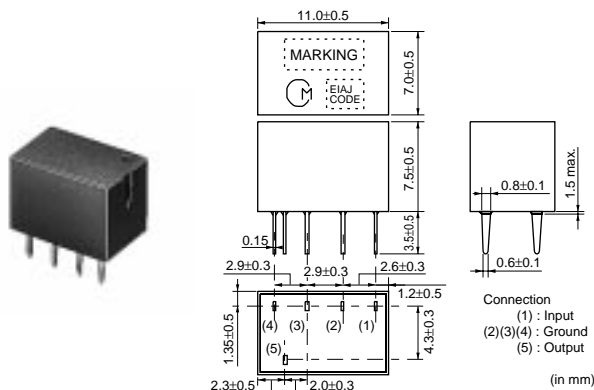

Part Number	Center Frequency (fo) (kHz)	6dB Bandwidth (kHz)	Stop Bandwidth (kHz)	Stop Band Attenuation (dB)	Insertion Loss (dB)	GDT Deviation (μs)	Input/Output Impedance (ohm)
CFWLA455KB4Y-B0	455 ±1.5kHz	fn±15.0 min.	fn±35.0 max. [within 50dB]	40 min. [within fn±100kHz]	6.0 max. [at minimum loss point]	30.0 max. [within fn±10kHz]	1500
CFWLA455KC4Y-B0	455 ±1.5kHz	fn±12.5 min.	fn±30.0 max. [within 50dB]	40 min. [within fn±100kHz]	7.0 max. [at minimum loss point]	30.0 max. [within fn±8kHz]	1500
CFWLA455KD1Y-B0	455 ±1.0kHz	fn±10.0 min.	fn±25.0 max. [within 50dB]	40 min. [within fn±100kHz]	8.0 max. [at minimum loss point]	30.0 max. [within fn±7kHz]	1500
CFWLA455KE1Y-B0	455 ±1.0kHz	fn±7.5 min.	fn±20.0 max. [within 50dB]	40 min. [within fn±100kHz]	9.0 max. [at minimum loss point]	30.0 max. [within fn±5kHz]	1500
CFWLA455KF1Y-B0	455 ±1.0kHz	fn±6.0 min.	fn±17.5 max. [within 50dB]	40 min. [within fn±100kHz]	10.0 max. [at minimum loss point]	40.0 max. [within fn±4kHz]	2000
CFWLA455KG1Y-B0	455 ±1.0kHz	fn±4.5 min.	fn±15.0 max. [within 50dB]	40 min. [within fn±100kHz]	11.0 max. [at minimum loss point]	40.0 max. [within fn±3kHz]	2000

Center frequency (fo) defined by the center of 6dB bandwidth.

(fn) means nominal center frequency 455kHz.

For safety purposes, connect the output of filters to the IF amplifier through a D.C. blocking capacitor. Avoid applying a direct current to the output of ceramic filters.

The order quantity should be an integral multiple of the "Minimum Quantity" shown in package page in this catalog.

△Note • This PDF catalog is downloaded from the website of Murata Manufacturing co., Ltd. Therefore, it's specifications are subject to change or our products in it may be discontinued without advance notice. Please check with our sales representatives or product engineers before ordering.
• This PDF catalog has only typical specifications because there is no space for detailed specifications. Therefore, please approve our product specifications or transact the approval sheet for product specifications before ordering.

● Plastic Case Group Delay Flat Type Miniaturized Type CFULB_Y Series

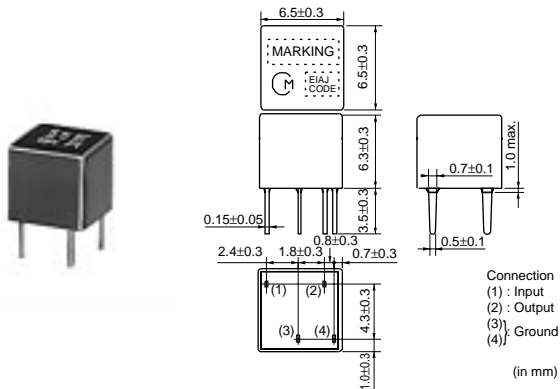

Part Number	Center Frequency (fo) (kHz)	6dB Bandwidth (kHz)	Stop Bandwidth (kHz)	Stop Band Attenuation (dB)	Insertion Loss (dB)	GDT Deviation (μs)	Input/Output Impedance (ohm)
CFULB455KB4Y-B0	455 ±1.5kHz	fn±15.0 min.	fn±35.0 max. [within 40dB]	25 min. [within fn±100kHz]	5.0 max. [at minimum loss point]	15.0 max. [within fn±10kHz]	1500
CFULB455KC4Y-B0	455 ±1.5kHz	fn±12.5 min.	fn±30.0 max. [within 40dB]	25 min. [within fn±100kHz]	6.0 max. [at minimum loss point]	15.0 max. [within fn±8kHz]	1500
CFULB455KD1Y-B0	455 ±1.0kHz	fn±10.0 min.	fn±25.0 max. [within 40dB]	23 min. [within fn±100kHz]	7.0 max. [at minimum loss point]	20.0 max. [within fn±7kHz]	1500
CFULB455KE1Y-B0	455 ±1.0kHz	fn±7.5 min.	fn±20.0 max. [within 40dB]	23 min. [within fn±100kHz]	8.0 max. [at minimum loss point]	20.0 max. [within fn±5kHz]	1500
CFULB455KF1Y-B0	455 ±1.0kHz	fn±6.0 min.	fn±17.5 max. [within 40dB]	23 min. [within fn±100kHz]	9.0 max. [at minimum loss point]	20.0 max. [within fn±4kHz]	2000
CFULB455KG1Y-B0	455 ±1.0kHz	fn±4.5 min.	fn±15.0 max. [within 40dB]	23 min. [within fn±100kHz]	10.0 max. [at minimum loss point]	20.0 max. [within fn±3kHz]	2000

Center frequency (fo) defined by the center of 6dB bandwidth.

(fn) means nominal center frequency 455kHz.

CFULB455K_Y series filters are 4-element ceramic filters and miniature versions of CFULA455K_Y series.

For safety purposes, connect the output of filters to the IF amplifier through a D.C. blocking capacitor. Avoid applying a direct current to the output of ceramic filters.

The order quantity should be an integral multiple of the "Minimum Quantity" shown in package page in this catalog.

Filters for Communication Equipment

● Plastic Case Group Delay Flat Type CFWL_B_Y Series

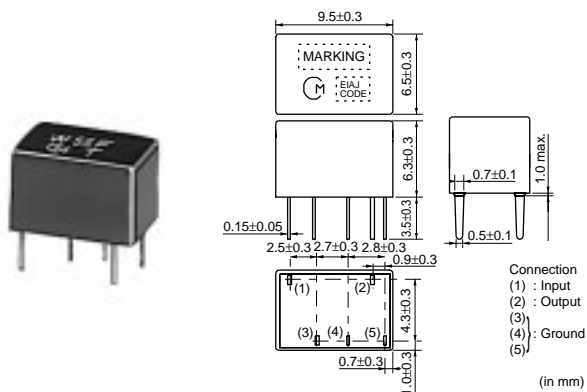

Part Number	Center Frequency (fo) (kHz)	6dB Bandwidth (kHz)	Stop Bandwidth (kHz)	Stop Band Attenuation (dB)	Insertion Loss (dB)	GDT Deviation (μs)	Input/Output Impedance (ohm)
CFWL455KB4Y-B0	455 ±1.5kHz	fn±15.0 min.	fn±30.0 max. [within 50dB]	40 min. [within fn±100kHz]	6.0 max. [at minimum loss point]	30.0 max. [within fn±10kHz]	1500
CFWL455KC4Y-B0	455 ±1.5kHz	fn±12.5 min.	fn±27.5 max. [within 50dB]	40 min. [within fn±100kHz]	7.0 max. [at minimum loss point]	30.0 max. [within fn±8kHz]	1500
CFWL455KD1Y-B0	455 ±1.0kHz	fn±10.0 min.	fn±25.0 max. [within 50dB]	40 min. [within fn±100kHz]	8.0 max. [at minimum loss point]	30.0 max. [within fn±7kHz]	1500
CFWL455KE1Y-B0	455 ±1.0kHz	fn±7.5 min.	fn±20.0 max. [within 50dB]	40 min. [within fn±100kHz]	9.0 max. [at minimum loss point]	30.0 max. [within fn±5kHz]	1500

Continued on the following page.

Note • This PDF catalog is downloaded from the website of Murata Manufacturing co., ltd. Therefore, it's specifications are subject to change or our products in it may be discontinued without advance notice. Please check with our sales representatives or product engineers before ordering.
• This PDF catalog has only typical specifications because there is no space for detailed specifications. Therefore, please approve our product specifications or transact the approval sheet for product specifications before ordering.

Continued from the preceding page.

Part Number	Center Frequency (fo) (kHz)	6dB Bandwidth (kHz)	Stop Bandwidth (kHz)	Stop Band Attenuation (dB)	Insertion Loss (dB)	GDT Deviation (μs)	Input/Output Impedance (ohm)
CFWLB455KF1Y-B0	455 ±1.0kHz	fn±6.0 min.	fn±17.5 max. [within 50dB]	40 min. [within fn±100kHz]	10.0 max. [at minimum loss point]	40.0 max. [within fn±4kHz]	2000
CFWLB455KG1Y-B0	455 ±1.0kHz	fn±4.5 min.	fn±15.0 max. [within 50dB]	40 min. [within fn±100kHz]	11.0 max. [at minimum loss point]	40.0 max. [within fn±3kHz]	2000

Center frequency (fo) defined by the center of 6dB bandwidth.

(fn) means nominal center frequency 455kHz.

CFWLB455K_Y series filters are 4-element ceramic filters and miniature versions of CFWLA455K_Y series.

For safety purposes, connect the output of filters to the IF amplifier through a D.C. blocking capacitor. Avoid applying a direct current to the output of ceramic filters.

The order quantity should be an integral multiple of the "Minimum Quantity" shown in package page in this catalog.

for IF

Ceramic Filters (10.7MHz)

● Small Chip Type SFECF Series (Standard Type)

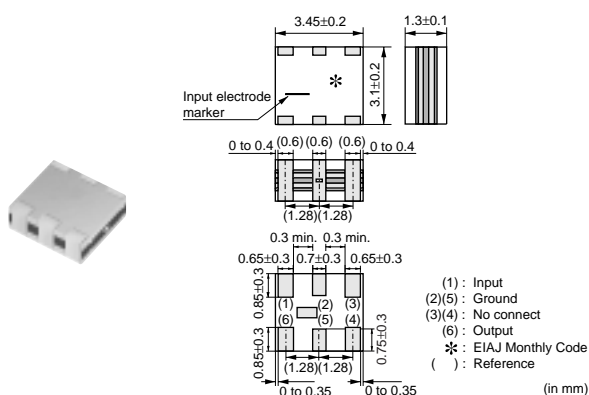

Part Number	Center Frequency (fo) (MHz)	Nominal Center Frequency (fn) (MHz)	3dB Bandwidth (kHz)	Attenuation (kHz)	Insertion Loss (dB)	Ripple (dB)	Spurious Attenuation (1) (dB)	Input/Output Impedance (ohm)	Spurious Attenuation (2) (dB)
SFECF10M7HA00-R0	10.700 ±30kHz	-	180 ±40kHz	470 max.	4.0 ±2.0dB	1.0 max.	30 min. [within 9MHz to fo]	330	30 min. [within fo to 12MHz]
SFECF10M7HF00-R0	-	10.700	fn±25 min.	510 max.	8.0 max. [at fn]	1.0 max.	30 min. [within 9MHz to fn]	330	25 min. [within fn to 12MHz]
SFECF10M7GA00-R0	10.700 ±30kHz	-	230 ±50kHz	510 max.	3.5 ±2.0dB	1.0 max.	30 min. [within 9MHz to fo]	330	30 min. [within fo to 12MHz]
SFECF10M7GF00-R0	-	10.700	fn±45 min.	560 max.	8.0 max. [at fn]	1.0 max.	30 min. [within 9MHz to fn]	330	25 min. [within fn to 12MHz]
SFECF10M7FA00-R0	10.700 ±30kHz	-	280 ±50kHz	590 max.	3.0 ±2.0dB	1.0 max.	30 min. [within 9MHz to fo]	330	30 min. [within fo to 12MHz]
SFECF10M7FF00-R0	-	10.700	fn±65 min.	620 max.	7.0 max. [at fn]	1.0 max.	30 min. [within 9MHz to fn]	330	25 min. [within fn to 12MHz]
SFECF10M7EA00-R0	10.700 ±30kHz	-	330 ±50kHz	700 max.	3.0 ±2.0dB	1.0 max.	30 min. [within 9MHz to fo]	330	30 min. [within fo to 12MHz]
SFECF10M7DA0001-R0	10.700 ±30kHz	-	420 min.	950 max.	3.0 ±2.0dB	3.0 max.	35 min. [within 9MHz to fo]	330	25 min. [within fo to 12MHz]
SFECF10M7DF00-R0	-	10.700	fn±150 min.	990 max.	6.0 max. [at fn]	3.0 max.	20 min. [within 9MHz to fn]	330	20 min. [within fn to 12MHz]

Area of Attenuation: [within 20dB]

Area of Spurious Attenuation: [within 9MHz to 12MHz]

Area of Insertion Loss: at minimum loss point

Area of Ripple: within 3dB B.W.

Center frequency (fo) defined by center of 3dB bandwidth.

For safety purposes, connect the output of filters to the IF amplifier through a D.C. blocking capacitor. Avoid applying a direct current to the output of ceramic filters.

The order quantity should be an integral multiple of the "Minimum Quantity" shown in package page in this catalog.

△Note • This PDF catalog is downloaded from the website of Murata Manufacturing co., ltd. Therefore, it's specifications are subject to change or our products in it may be discontinued without advance notice. Please check with our sales representatives or product engineers before ordering.
• This PDF catalog has only typical specifications because there is no space for detailed specifications. Therefore, please approve our product specifications or transact the approval sheet for product specifications before ordering.

● Small Chip Type SFECF Series (High-reliability Type)

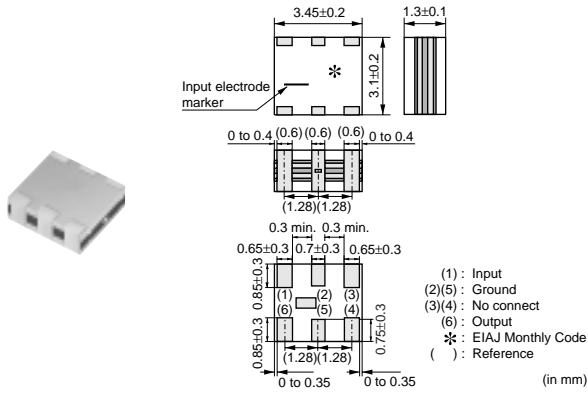

Part Number	Center Frequency (fo) (MHz)	Nominal Center Frequency (fn) (MHz)	3dB Bandwidth (kHz)	Attenuation (kHz)	Insertion Loss (dB)	Ripple (dB)	Spurious Attenuation (1) (dB)	Input/Output Impedance (ohm)	Spurious Attenuation (2) (dB)
SFECF10M7HA00S0-R0	10.700 ±30kHz	-	180 ±40kHz	470 max.	4.0 ±2.0dB	1.0 max.	30 min. [within 9MHz to fo]	330	30 min. [within fo to 12MHz]
SFECF10M7HF00S0-R0	-	10.700	fn±25 min.	510 max.	8.0 max. [at fn]	1.0 max.	30 min. [within 9MHz to fn]	330	25 min. [within fn to 12MHz]
SFECF10M7GA00S0-R0	10.700 ±30kHz	-	230 ±50kHz	510 max.	3.5 ±2.0dB	1.0 max.	30 min. [within 9MHz to fo]	330	30 min. [within fo to 12MHz]
SFECF10M7GF00S0-R0	-	10.700	fn±45 min.	560 max.	8.0 max. [at fn]	1.0 max.	30 min. [within 9MHz to fn]	330	25 min. [within fn to 12MHz]
SFECF10M7FA00S0-R0	10.700 ±30kHz	-	280 ±50kHz	590 max.	3.0 ±2.0dB	1.0 max.	30 min. [within 9MHz to fo]	330	30 min. [within fo to 12MHz]
SFECF10M7FF00S0-R0	-	10.700	fn±65 min.	630 max.	7.0 max. [at fn]	1.0 max.	30 min. [within 9MHz to fn]	330	25 min. [within fn to 12MHz]
SFECF10M7EA00S0-R0	10.700 ±30kHz	-	330 ±50kHz	700 max.	3.0 ±2.0dB	1.0 max.	30 min. [within 9MHz to fo]	330	30 min. [within fo to 12MHz]
SFECF10M7DF00S0-R0	-	10.700	fn±145 min.	990 max.	6.0 max. [at fn]	3.0 max.	20 min. [within 9MHz to fn]	330	20 min. [within fn to 12MHz]

Area of Attenuation: [within 20dB]

Area of Spurious Attenuation: [within 9MHz to 12MHz]

Area of Insertion Loss: at minimum loss point

Area of Ripple: within 3dB B.W.

Center frequency (fo) defined by center of 3dB bandwidth.

For safety purposes, connect the output of filters to the IF amplifier through a D.C. blocking capacitor. Avoid applying a direct current to the output of ceramic filters.

The order quantity should be an integral multiple of the "Minimum Quantity" shown in package page in this catalog.

7 Filters for Communication Equipment

for IF

Ceramic Discriminators (10.7MHz)

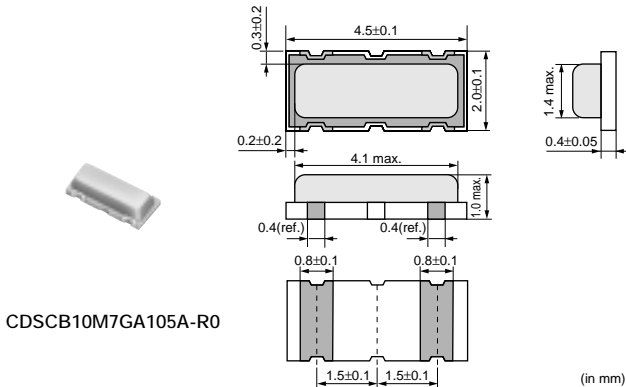

CDSCB10M7GA105A-R0

(in mm)

Part Number	Center Frequency (fo) (MHz)	Recovered Audio 3dB BW (kHz)	Recovered Audio Output (mV)	Distortion (%)	S Curve (mV)	IC
CDSCB10M7GA105A-R0	10.700 ±30kHz	220 min.	110 min.	1.5 max.	-	TEA5757HL
CDSCB10M7GA113-R0	10.700 ±30kHz	300 min.	110 min.	1.0 max.	-	TA2154FN
CDSCB10M7GA119-R0	10.700 ±30kHz	500 min.	75 min.	1.0 max.	-	TRF6901
CDSCB10M7GA121-R0	10.700 ±30kHz	390 min.	80 min.	1.0 max.	-	LV23100V
CDSCB10M7GA135-R0	10.700 ±30kHz	155 min.	75 min.	-	-	TH71101
CDSCB10M7GA136-R0	10.700 ±30kHz	140 min.	120 min.	-	-	TH7122
CDSCB10M7GF072-R0	10.700 (fn)	fn±150 min.	130 min.	2.0 max.	-	TA31161
CDSCB10M7GF107S-R0	10.700 (fn)	fn±80 min.	52 min.	3.0 max.	-	TA31272FN
CDSCB10M7GF109-R0	10.700 (fn)	fn±100 min.	170 min.	3.0 max.	-	TK14588V
CDSCB10M7GF123-R0	10.700 (fn)	-	-	-	900 min.	TA31275FN
CDSCB10M7GF123S-R0	10.700 (fn)	-	-	-	900 min.	TA31275FN
CDSCB10M7GF126-R0	10.700 (fn)	-	-	-	400 min.	NJM2295AV

For safety purpose, avoid applying a direct current between the terminals.

(fn) means nominal center frequency.

The order quantity should be an integral multiple of the "minimum quantity" shown in the package page.

for IF

Ceramic Discriminators (455kHz)

● kHz Specified by Impedance Characteristics (Type 1)

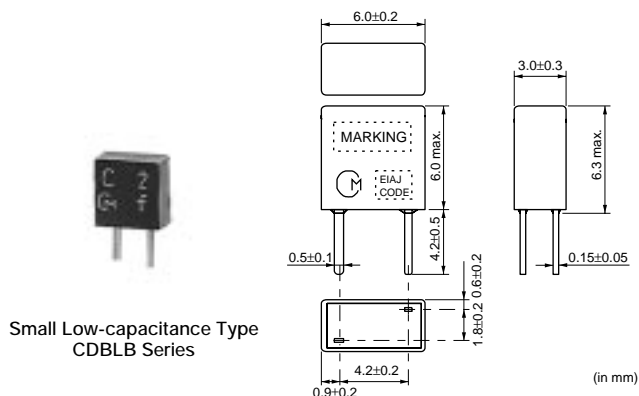

Small Low-capacitance Type CDBLB Series

Part Number	Nominal Center Frequency (fn) (kHz)	Inclination of Impedance Curve (1)	Inclination of Impedance Curve (2)	Capacitance (C)	IC
CDBLB455KCAX02-B0	455	447.0±1.5kHz (at Z =2.05kohm)	463.0±1.5kHz (at Z =10.0kohm)	140pF±20%	TA8104F
CDBLB455KCAX31-B0	455	447.0±1.5kHz (at Z =2.05kohm)	463.0±1.5kHz (at Z =10.0kohm)	140pF±20%	TA31141

For safety purposes, avoid applying a direct current between the terminals.

The order quantity should be an integral multiple of the "Minimum Quantity" shown in package page in this catalog.

● kHz Specified by Impedance Characteristics (Type 2)

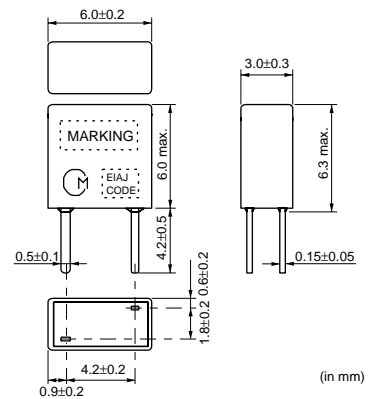
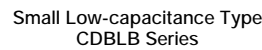
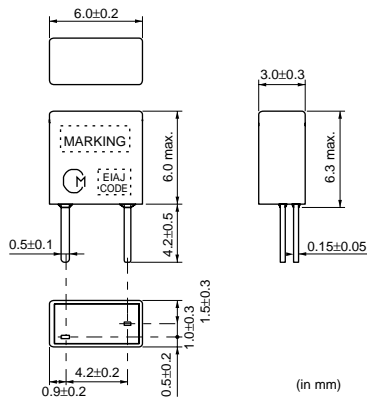
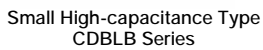
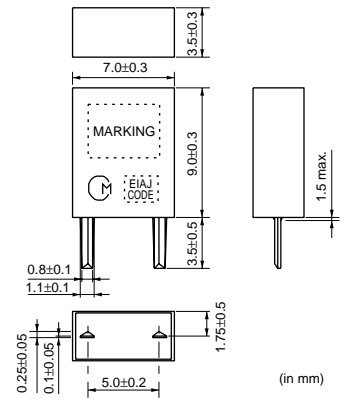
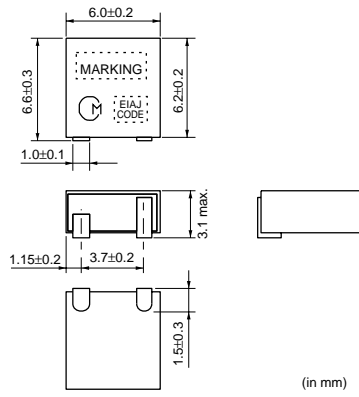

7 Filters for Communication Equipment

Part Number	Nominal Center Frequency (fn)	Anti-resonant Frequency (Fa)	Delta F (Fa-Fr)	Resonant Resistance (R)	Capacitance (C)	IC
CDBKB455KCAX33-R0	-	462.0±1.5kHz	40±4.0kHz	200ohm max.	150pF±20%	CXA1474
CDBLA455KCAY03-B0	-	455.0±1.5kHz	48±5.0kHz	70ohm max.	600pF±20%	CXA1184M
CDBLB455KCAY03-B0	-	455.0±1.5kHz	46±5.0kHz	70ohm max.	550pF±20%	CXA1184M
CDBLB455KCAX15-B0	-	463.5±1.0kHz	43±2.0kHz	300ohm max.	140pF±20%	CXA1183M
CDBLB455KCAX25-B0	-	465.0±1.5kHz	45±4.0kHz	300ohm max.	135pF±20%	CXA1484
CDBLB455KCAX33-B0	-	465.0±1.5kHz	45±4.0kHz	300ohm max.	135pF±20%	CXA1474

For safety purposes, avoid applying a direct current between the terminals.
 The order quantity should be an integral multiple of the "Minimum Quantity" shown in package page in this catalog.

● kHz Specified by Recovered Audio Characteristics

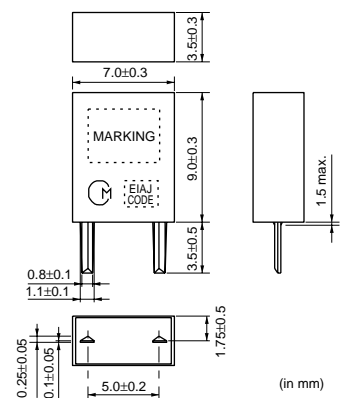
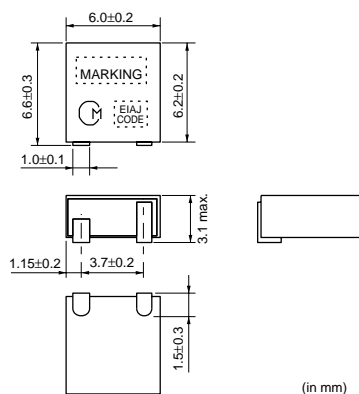

Continued on the following page. ↗

△Note • This PDF catalog is downloaded from the website of Murata Manufacturing co., Ltd. Therefore, it's specifications are subject to change or our products in it may be discontinued without advance notice. Please check with our sales representatives or product engineers before ordering.
 • This PDF catalog has only typical specifications because there is no space for detailed specifications. Therefore, please approve our product specifications or transact the approval sheet for product specifications before ordering.

Continued from the preceding page.

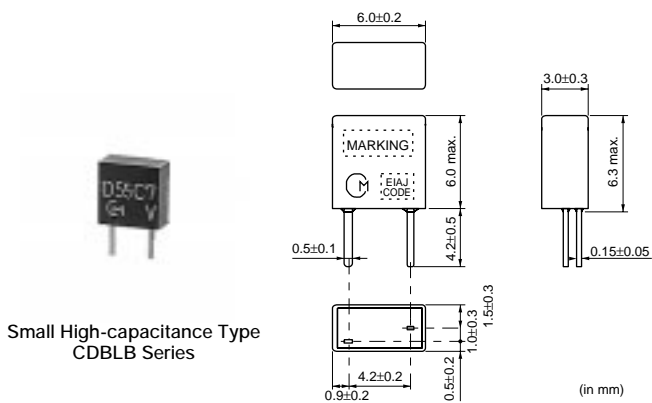

Small High-capacitance Type
CDBLB Series

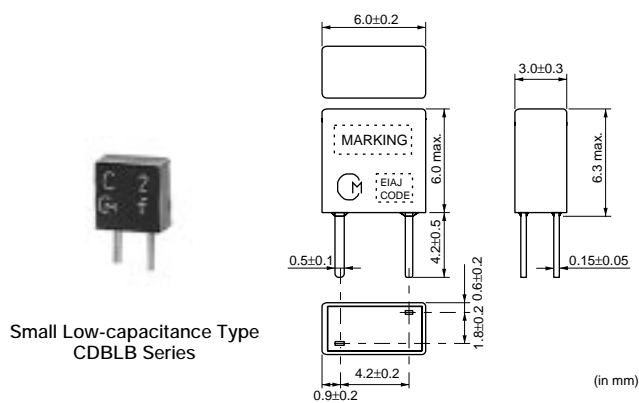

Small Low-capacitance Type
CDBLB Series

Part Number	Nominal Center Frequency (fn) (kHz)	Recovered Audio 3dB BW (kHz)	Recovered Audio Output (mV)	Distortion (at fn) (%)	Distortion (%)	IC
CDBKB450KCAY79-R0	450	fn±3.0 min.	145 ±40	-	-	TB32302FG
CDBKB455KCAY07-R0	455	fn±4.0 min.	350 ±60	3.0 max.	-	MC3357
CDBKB455KCAY09-R0	455	fn±4.0 min.	120 ±40	1.5 max.	-	NE604N
CDBKB455KCAY13-R0	455	fn±4.0 min.	330 ±50	4.0 max.	-	CXA1003BM
CDBKB455KCAY16-R0	455	fn±4.0 min.	175 ±40	2.0 max.	-	MC3372
CDBKB455KCAY24-R0	455	fn±4.0 min.	100 ±40	2.0 max.	-	TA31136
CDBKB455KCAY27-R0	455	fn±4.0 min.	90 ±30	2.0 max.	-	TK10487
CDBKB455KCAY28-R0	455	fn±4.0 min.	40 ±20	3.0 max.	-	TA31142F
CDBKB455KCAY29-R0	455	fn±4.0 min.	100 ±30	2.5 max.	-	NE605
CDBKB455KCAY35-R0	455	fn±4.0 min.	100 ±40	2.5 max.	-	TK10930
CDBKB455KCAY40-R0	455	fn±4.0 min.	40 ±20	3.5 max.	-	TA31145
CDBKB455KCAY49-R0	455	fn±4.0 min.	45 ±10	3.0 max.	-	MC3361
CDBKB455KCAY50-R0	455	fn±4.0 min.	64 ±6.4	4.0 max.	-	CXA3117N
CDBKB455KCAY66-R0	455	fn±4.2 min.	40 ±10	4.0 max.	-	NJM2590
CDBKB455KCLX36-R0	455	fn±13.0 min.	90 ±30	2.5 max.	5.0 max. [within fn ±6kHz]	NE(SA)606 /NE(SA)616
CDBKB455KCLX39-R0	455	fn±11.0 min.	130 ±20	2.5 max.	7.0 max. [within fn ±8kHz]	NE607 /NE617
CDBKB455KCLY13-R0	455	fn±13.0 min.	120 ±30	1.5 max.	5.0 max. [within fn ±8kHz]	CXA1003BM
CDBLA455KCAY07-B0	455	fn±4.0 min.	340 ±60	2.5 max.	-	MC3357
CDBLA455KCAY09-B0	455	fn±5.0 min.	100 min.	1.5 max.	-	NE604N
CDBLA455KCAY13A-B0	455	fn±4.0 min.	350 ±50	3.0 max.	-	CXA1003BM

Continued on the following page.

Note • This PDF catalog is downloaded from the website of Murata Manufacturing co., Ltd. Therefore, its specifications are subject to change or our products in it may be discontinued without advance notice. Please check with our sales representatives or product engineers before ordering.
• This PDF catalog has only typical specifications because there is no space for detailed specifications. Therefore, please approve our product specifications or transact the approval sheet for product specifications before ordering.

Continued from the preceding page.

Part Number	Nominal Center Frequency (fn) (kHz)	Recovered Audio 3dB BW (kHz)	Recovered Audio Output (mV)	Distortion (at fn) (%)	Distortion (%)	IC
CDBLA455KCAY16-B0	455	fn±4.0 min.	185 ±40	2.0 max.	-	MC3372
CDBLA455KCAY24-B0	455	fn±4.0 min.	100 ±40	2.0 max.	-	TA31136
CDBLA455KCAY28-B0	455	fn±4.0 min.	40 ±20	3.0 max.	-	TA31142
CDBLA455KCAY34-B0	455	fn±4.0 min.	65 ±20	2.5 max.	-	MC13136
CDBLA455KCLY09-B0	455	fn±15.0 min.	70 ±20	1.5 max.	3.5 max. [within fn ±8kHz]	NE604N
CDBLA455KCLY13-B0	455	fn±15.0 min.	110 ±30	1.5 max.	5.0 max. [within fn ±8kHz]	CXA1003BM
CDBLB455KCAY07-B0	455	fn±4.0 min.	340 ±60	3.0 max.	-	MC3357
CDBLB455KCAY13A-B0	455	fn±4.0 min.	350 ±50	3.0 max.	-	CXA1003BM
CDBLB455KCAY24-B0	455	fn±4.0 min.	100 ±40	2.0 max.	-	TA31136
CDBLB455KCAY28-B0	455	fn±4.0 min.	40 ±20	3.0 max.	-	TA31142FN
CDBLB455KCAY34-B0	455	fn±4.0 min.	65 ±20	2.5 max.	-	MC13136
CDBLB455KCAY40-B0	455	fn±4.0 min.	40 ±20	3.0 max.	-	TA31145
CDBLB455KCAY42-B0	455	fn±4.0 min.	40 ±15	3.0 max.	-	TK14590 /TK14591
CDBLB455KCAY49-B0	455	fn±4.0 min.	45 ±10	3.0 max.	-	MC3361
CDBLB455KCAY50-B0	455	fn±4.0 min.	64 ±6.4	4.0 max.	-	CXA3117N
CDBLB455KCLY09-B0	455	fn±15.0 min.	70 ±20	1.5 max.	3.5 max. [within fn ±8kHz]	NE604N
CDBLB455KCLY13-B0	455	fn±15.0 min.	110 ±30	1.5 max.	5.0 max. [within fn ±8kHz]	CXA1003BM
CDBLB455KCAX16-B0	455	fn±4.0 min.	185 ±40	2.0 max.	-	MC3372
CDBLB455KCAX18-B0	455	fn±3.0 min.	180 ±40	2.0 max.	-	MC3371
CDBLB455KCAX36-B0	455	fn±3.5 min.	100 ±25	3.5 max.	-	NE606 /NE616

For safety purposes, avoid applying a direct current between the terminals.

The order quantity should be an integral multiple of the "Minimum Quantity" shown in package page in this catalog.

● kHz Specified by S Curve Characteristics

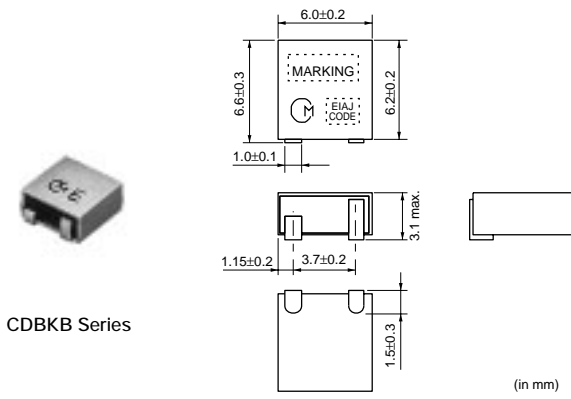

CDBKB Series

Part Number	Nominal Center Frequency (fn) (kHz)	S Curve (1) at fn (mV)	S Curve (2) (mV)	IC
CDBKB455KCAY54-R0	455	165 ±20	170 ±20	TA31149

For safety purposes, avoid applying a direct current between the terminals.

The order quantity should be an integral multiple of the "Minimum Quantity" shown in package page in this catalog.

for IF

BGS Filters

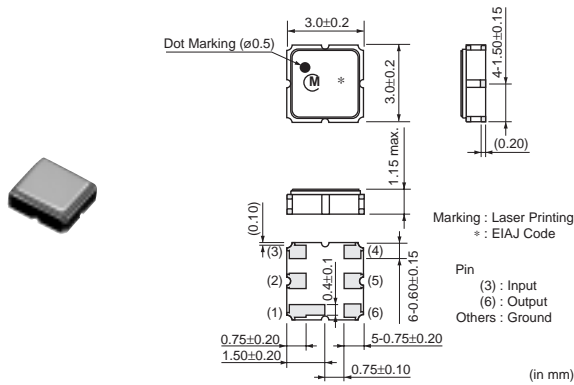

Part Number	Nominal Center Frequency(fn) (MHz)	3dB Bandwidth (MHz)
MKFCC40M0CD0P00	40.00	fn±1.5 min.

△Note • This PDF catalog is downloaded from the website of Murata Manufacturing co., ltd. Therefore, it's specifications are subject to change or our products in it may be discontinued without advance notice. Please check with our sales representatives or product engineers before ordering.
 • This PDF catalog has only typical specifications because there is no space for detailed specifications. Therefore, please approve our product specifications or transact the approval sheet for product specifications before ordering.

8

Microwave Components

Isolators

Chip Multilayer Hybrid Couplers

Hybrid Dividers

Chip Multilayer Diplexers

Chip Multilayer Hybrid Baluns

Chip Antennas

High Frequency Monolithic Ceramic Capacitors

High Frequency Single Layer Microchip Capacitors

Thin Film Circuit Substrate (RUSUB®)

Coaxial Connectors

Coaxial Connectors with Switches

● Part Numbering

Isolators

(Part Number) **CE** **S30** **1G95** **DCB000** **RAB**
 ① ② ③ ④ ⑤

① Product ID

Product ID	
CE	Isolators

② Series

Code	Series
G23	2.0×2.0×1.0mm
S20	3.2×2.5×1.2mm
S30	3.2×3.2×1.6mm
S32	3.2×3.2×1.5mm
S40	4.0×4.0×1.7mm

③ Nominal Center Frequency

Expressed by four-digits alphanumerics. If the unit is "MHz", it is expressed by three figures plus "M". If the unit is "GHz", a decimal point is expressed by capital letter "G".

④ Individual Specification Code

Expressed by three letters and one figure.

⑤ Packaging

Code	Packaging
RA1	1000 pcs. /Reel (CES20, CEG23)
RAB	500 pcs. /Reel (CES30, CES32, CES40)
RB2	2000 pcs. /Reel (CES30, CES40)
RB3	3000 pcs. /Reel (CES32)
RB4	4000 pcs. /Reel (CES20)
RB5	5000 pcs. /Reel (CEG23)

Chip Multilayer Hybrid Couplers/Chip Multilayer Hybrid Dividers

(Part Number) **LD** **C** **21** **897M** **20** **B** **-027**
 ① ② ③ ④ ⑤ ⑥ ⑦

① Product ID

② Function

③ Dimension (L×W)

④ Nominal Center Frequency

Expressed by four-digits alphanumerics. The unit is hertz (Hz). If the unit is "MHz", it is expressed by three figures plus "M". If the unit is "GHz", a decimal point is expressed by capital letter "G".

⑤ Coupling

⑥ Design

⑦ Individual Specification Code

Chip Multilayer Hybrid Baluns

(Part Number) **LD** **B** **21** **836M** **20** **C** **-001**
 ① ② ③ ④ ⑤ ⑥ ⑦

① Product ID

② Function

③ Dimension (L×W)

④ Nominal Center Frequency

Expressed by four-digits alphanumerics. The unit is hertz (Hz). If the unit is "MHz", it is expressed by three figures plus "M". If the unit is "GHz", a decimal point is expressed by capital letter "G".

⑤ Balance Impedance

⑥ Design

⑦ Individual Specification Code

Chip Multilayer Antenna

(Part Number) **LD** **A** **31** **2G73** **13** **F** **-237**
 ① ② ③ ④ ⑤ ⑥ ⑦

① Product ID

② Function

③ Dimension (L×W)

④ Nominal Center Frequency

Expressed by four-digits alphanumerics. The unit is hertz (Hz). If the unit is "MHz", it is expressed by three figures plus "M". If the unit is "GHz", a decimal point is expressed by capital letter "G".

⑤ Dimension (T)

⑥ Design

⑦ Individual Specification Code

Chip Dielectric Antennas

(Part Number) **AN** **C** **V1** **2G44** **SAA127** **R** **B** **3**

①
②
③
④
⑤
⑥
⑦
⑧

- ① Product ID
- ② Function
- ③ Series
- ④ Nominal Center Frequency

Expressed by four-digits alphanumerics. The unit is hertz (Hz). If the unit is "MHz", it is expressed by three figures plus "M". If the unit is "GHz", a decimal point is expressed by capital letter "G".

- ⑤ Individual Specification Code
- ⑥ Package Product ID
- ⑦ Package Detail(1)
- ⑧ Package Detail(2)

High Frequency Single Layer Microchip Capacitors

(Part Number) **CL** **B** **05** **B5** **390** **K** **1** **000** **TC1**

①
②
③
④
⑤
⑥
⑦
⑧
⑨

- ① Product ID
- ② Series
- ③ Size

Code	Size (L×W)
0A	0.25×0.25mm
0B	0.30×0.25mm
0C	0.35×0.25mm
0D	0.38×0.38mm
0E	0.55×0.38mm
0H	0.71×0.38mm
05	0.50×0.50mm
0G	0.70×0.50mm
0K	0.90×0.50mm
0F	0.64×0.64mm
1A	1.00×0.64mm
0J	0.76×0.76mm
1B	1.09×0.76mm
09	0.90×0.90mm
1E	1.49×0.90mm
1C	1.27×1.27mm
1G	1.73×1.27mm
2C	2.19×1.27mm
1H	1.78×1.78mm
2L	2.95×1.78mm
2E	2.29×2.29mm
3G	3.71×2.29mm

④ Temperature Characteristics

Code	Temperature Range	Capacitance Change
5C	-25 to 85°C	0±30ppm/°C
6U	-25 to 85°C	-750±60ppm/°C
7K	-25 to 85°C	-2200±500ppm/°C
B5	-25 to 85°C	±10%
F9	-25 to 85°C	+30,-80%
W1	-25 to 85°C	+30,-90%

*Reference Temp. : 25°C



5 Capacitance

Expressed by three-digit alphanumerics. The unit is pico-farad (pF). The first and second figures are significant digits, and the third figure expresses the number of zeros which follow the two numbers.

If there is a decimal point, it is expressed by the capital letter "R". In this case, all figures are significant digits.

6 Capacitance Tolerance

Code	Capacitance Tolerance
B	±0.1pF
K	±10%
M	±20%
Z	+80%, -20%

7 Number of Electrodes

8 Individual Specification Code

9 Packaging

Code	Packaging
TC1	Tray

Coaxial Connectors (Chip Type Receptacle)

(Part Number) **MM** **8130** **-26** **00** **R** **B8**
① ② ③ ④ ⑤ ⑥

1 Product ID

Product ID	
MM	Microwave Coaxial Connectors (Chip Type Receptacle)

2 Series

Code	Series
4829	HSC Type
8130	SWF Type
8430	SWD Type
9329	GSC Type

3 Individual Specification Code (1)

Code	Individual Specification Code (1)
-26	Switch Connector SMD Type
-27	Connector SMD Type

4 Individual Specification Code (2)

Code	Individual Specification Code (2)
00	Serial

5 Package Product ID

Code	Package Product ID
B	Bulk
R	Reel



6 Package Detail

Code	Package Detail
A1	SWD, GSC Type 1000pcs. /Reel (ø178mm)
A4	HSC Type, 4000pcs. /Reel (ø178mm)
B0	HSC Type, 10000pcs. /Reel (ø330mm)
B3	SWD Type, 3000pcs. /Reel (ø330mm)
B5	GSC Type, 5000pcs. /Reel (ø330mm)
B8	SWF Type, 8000pcs. /Reel (ø330mm)

Coaxial Connectors (with Cable)

(Part Number) **MX** **HP** **32**
① ② ③ ④ ⑤ ⑥

1 Product ID

Product ID	
MX	Coaxial Connectors (with Cable)

2 Connector (1)

Code	Connector (1)
HP	HSC Type
TK	GSC Type

3 Cable

Code	Cable
32	0.4D, PFA, Single Shield Line, Spiral
92	0.4D, PFA, Single Shield Line, Spiral

4 Connector (2)

Code	Connector (2)
HP	HSC Type
TK	GSC Type
XX	None Connector

5 Length

Expressed by four figures. The unit is mm. From first to third figures are significant, and the fourth figure expresses the number of zeros which follow the three figures.

Ex.)

Code	Length
5000	500mm = 500 x 10 ⁰
1001	1000mm = 100 x 10 ¹

6 Individual Specification Code

Expressed by two sign.

Isolators

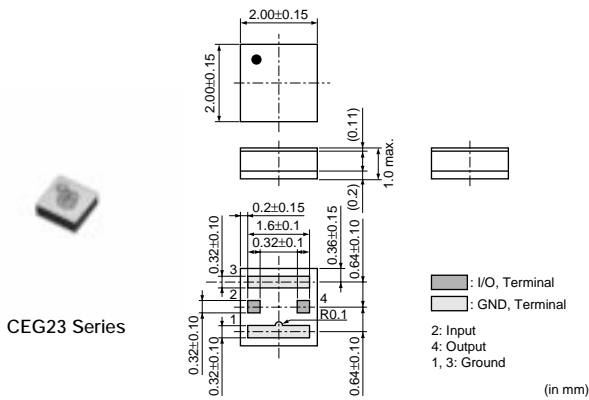

CEG23 Series

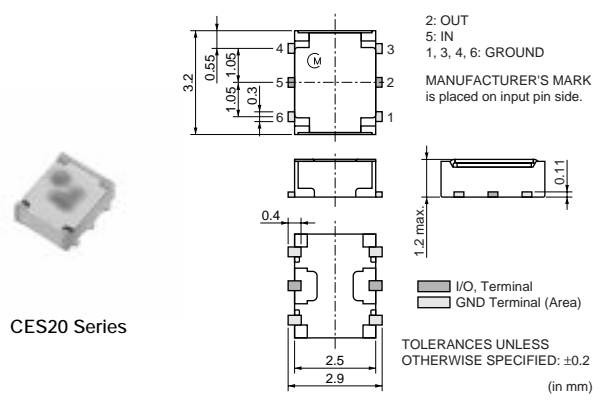

CES20 Series

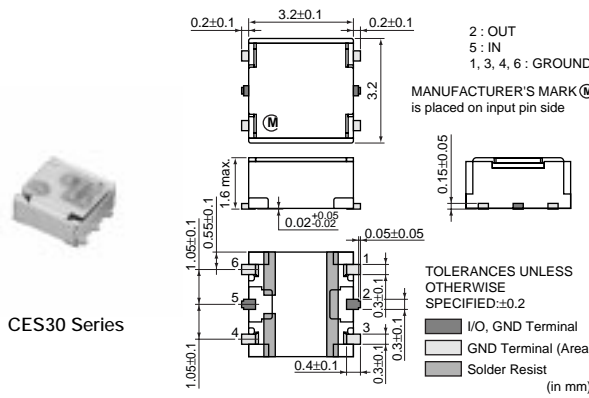

CES30 Series

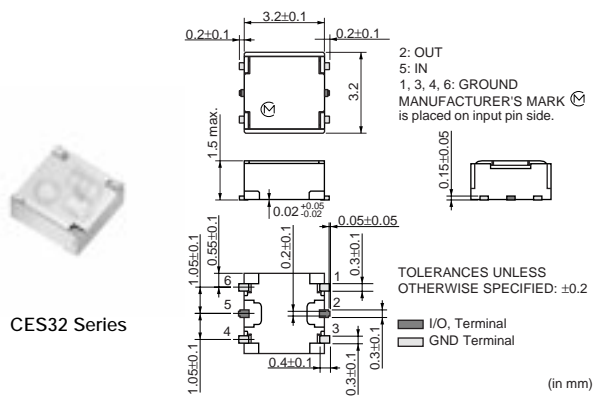

CES32 Series

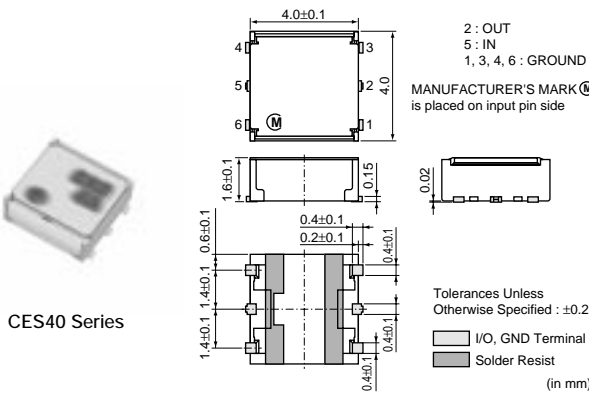

CES40 Series

Note • This PDF catalog is downloaded from the website of Murata Manufacturing co., Ltd. Therefore, it's specifications are subject to change or our products in it may be discontinued without advance notice. Please check with our sales representatives or product engineers before ordering.
• This PDF catalog has only typical specifications because there is no space for detailed specifications. Therefore, please approve our product specifications or transact the approval sheet for product specifications before ordering.

Part Number	Fo (MHz)	IL at BW (max.) (dB)	Isolation (min.) (dB)	Rating Power (max.) (W)
CEG23836MDCB000	836.5	0.65	10	1.2
CEG23874MFCB000	874.5	0.75	3.5	1.2
CEG23897MDCB000	897.5	0.68	9	1.2
CEG23911MDCB000	911.5	0.65	10	1.2
CEG231G73DCB100	1732.5	0.65	10	1.2
CEG231G76CCB100	1767.4	0.65	10	1.2
CEG231G88DCB100	1880	0.65	10	1.2
CEG231G95DCB100	1950	0.65	10	1.2
CES201G90CCB000	1900	0.6	13.5	2.5
CES202G01BCB000	2017.5	0.62	13.5	2.5
CES202G59ECB000	2592.5	0.9	6	2.5
CES301G74DCB000	1747.5	0.74	10.5	2.5
CES301G76CCB000	1765	0.7	12	2.5
CES301G84DCB000	1842.5	0.68	11	2.5
CES301G88DCB000	1880	0.64	13	2.5
CES301G90CCB000	1900	0.62	14.5	2.5
CES301G95DCB000	1950	0.6	13	2.5
CES301G96DCB000	1960	0.6	13	2.5
CES302G14DCB000	2140	0.62	13	2.5
CES321G95ECB000	1952.5	0.80	9.0	2.5
CES40836MDCB000	836.5	0.75	10.5	2.5
CES40881MDCB000	881.5	0.73	10	2.5
CES40897MDCB000	897.5	0.75	10	2.5
CES40906MDCB000	906	0.78	10	2.5
CES40942MDCB000	942.5	0.85	10	2.5

Chip Multilayer Hybrid Couplers

Directional Coupler

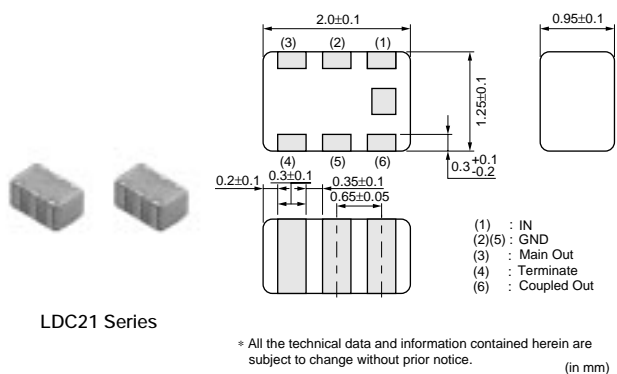
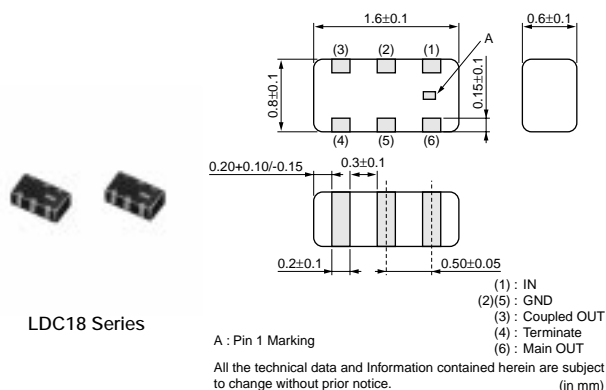
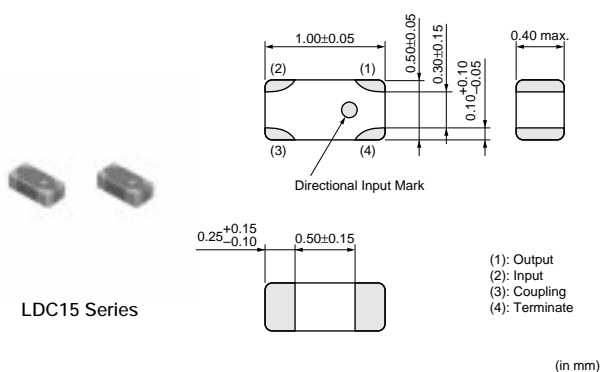

Part Number	Frequency Range (MHz)	Coupling (dB)	Insertion Loss (dB)	Isolation (min.) (dB)	VSWR (max.)	Characteristic Impedance (Nom.) (ohm)	Power Capacity (W)	Application
LDC15450M25Q-360	450 ±50MHz	25.1 ±1.8dB	0.15 max. (at 25°C)	38.0	1.5	50	3 max. (50ohm Load)	CDMA450
LDC15707M21Q-360	707 ±9MHz	21.1 ±1.0dB	0.23 max. (at 25°C)	35.0	1.4	50	3 max. (50ohm Load)	UMTS(Band12)
LDC15836M30Q-392	836.5 ±12.5MHz	30.6 ±1.0dB	0.20 max. (at 25°C)	38.0	1.4	50	3 max. (50ohm Load)	UMTS(Band5)
LDC15874M27Q-359	874 ±51MHz	27.2 ±1.0dB	0.20 max. (at 25°C)	42.0	1.4	50	3 max. (50ohm Load)	UMTS(Band5/8)
LDC15897M26Q-359	897.5 ±17.5MHz	26.9 ±1.0dB	0.20 max. (at 25°C)	42.0	1.4	50	3 max. (50ohm Load)	UMTS(Band8)
LDC151G4418Q-352	1441 ±12MHz	18.9 ±1.0dB	0.23 max. (at 25°C)	32.0	1.4	50	3 max. (50ohm Load)	WCDMA
LDC151G7313Q-360	1732.5 ±22.5MHz	13.6 ±1.0dB	0.42 max. (at 25°C)	24.0	1.4	50	3 max. (50ohm Load)	UMTS(Band4)
LDC151G7424Q-392	1747 ±37.5MHz	24.1 ±1.0dB	0.20 max. (at 25°C)	30.0	1.4	50	3 max. (50ohm Load)	UMTS(Band4)
LDC151G7421Q-359	1747.5 ±37.5MHz	21.2 ±1.0dB	0.22 max. (at 25°C)	35.0	1.4	50	3 max. (50ohm Load)	UMTS(Band3)
LDC151G8117Q-352	1810 ±100MHz	17.0 ±1.2dB	0.25 max. (at 25°C)	32.0	1.4	50	3 max. (50ohm Load)	GSM
LDC151G8620Q-359	1865 ±115MHz	20.5 ±1.0dB	0.22 max. (at 25°C)	34.0	1.4	50	3 max. (50ohm Load)	UMTS(Band2)
LDC151G8824Q-393	1880 ±30MHz	24.7 ±1.0dB	0.20 max. (at 25°C)	32.0	1.4	50	3 max. (50ohm Load)	UMTS(Band2)
LDC151G9120Q-359	1915 ±65MHz	20.4 ±1.0dB	0.22 max. (at 25°C)	34.0	1.4	50	3 max. (50ohm Load)	UMTS(Band1)

Continued on the following page.

Note • This PDF catalog is downloaded from the website of Murata Manufacturing co., ltd. Therefore, it's specifications are subject to change or our products in it may be discontinued without advance notice. Please check with our sales representatives or product engineers before ordering.
• This PDF catalog has only typical specifications because there is no space for detailed specifications. Therefore, please approve our product specifications or transact the approval sheet for product specifications before ordering.

Continued from the preceding page.

Part Number	Frequency Range (MHz)	Coupling (dB)	Insertion Loss (dB)	Isolation (min.) (dB)	VSWR (max.)	Characteristic Impedance (Nom.) (ohm)	Power Capacity (W)	Application
LDC151G9523Q-392	1950 ±30MHz	23.2 ±1.0dB	0.20 max. (at 25°C)	30.0	1.4	50	3 max. (50ohm Load)	UMTS(Band1)
LDC152G1419Q-359	2140 ±30MHz	19.4 ±1.0dB	0.26 max. (at 25°C)	33.0	1.5	50	3 max. (50ohm Load)	UMTS(Band1)
LDC152G3518Q-359	2350 ±50MHz	18.7 ±1.0dB	0.28 max. (at 25°C)	31.0	1.4	50	3 max. (50ohm Load)	WLAN
LDC152G4518Q-359	2450 ±50MHz	18.4 ±1.0dB	0.29 max. (at 25°C)	31.0	1.4	50	3 max. (50ohm Load)	WLAN
LDC152G5318Q-359	2535 ±35MHz	18.1 ±1.0dB	0.30 max. (at 25°C)	31.0	1.4	50	3 max. (50ohm Load)	UMTS(Band7)
LDC18836M32Q-370	836.5 ±12.5MHz	32.2 ±1.2dB	0.17 max. (at 25°C)	44.0	1.5	50	3 max. (50ohm Load)	UMTS(Band5)
LDC18897M20Q-361	897.5 ±17.5MHz	20.5 ±1.0dB	0.22 max. (at 25°C)	33.0	1.5	50	3 max. (50ohm Load)	UMTS(Band8)
LDC181G7426Q-370	1747.5 ±37.5MHz	26.0 ±1.2dB	0.17 max. (at 25°C)	49.0	1.5	50	3 max. (50ohm Load)	UMTS(Band4)
LDC181G8825Q-370	1880.0 ±30.0MHz	25.3 ±1.2dB	0.22 max. (at 25°C)	25.5	1.5	50	3 max. (50ohm Load)	UMTS(Band2)
LDC181G9525Q-370	1950.0 ±30.0MHz	25.0 ±1.2dB	0.22 max. (at 25°C)	44.0	1.5	50	3 max. (50ohm Load)	UMTS(Band1)
LDC21836M20B-027	836.5 ±12.5MHz	20.6 ±1.0dB	0.15 max. (at 25°C)	28.0	1.4	50	3 max. (50ohm Load)	CDMA
LDC211G8820B-042	1880.0 ±30.0MHz	20.0 ±1.0dB	0.23 max. (at 25°C)	26.0	1.4	50	3 max. (50ohm Load)	CDMA
LDC211G9517B-031	1950.0 ±30.0MHz	17.3 ±1.0dB	0.27 max. (at 25°C)	21.0	1.4	50	3 max. (50ohm Load)	UMTS(Band1)

Operating Temperature Range: -40°C to +85°C

Chip Multilayer Hybrid Couplers

Couplers with Integrated LPF

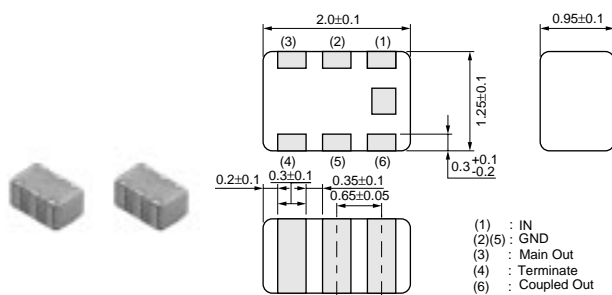

LDC21 Series

* All the technical data and information contained herein are subject to change without prior notice. (in mm)

Part Number	Frequency Range (MHz)	Coupling (dB)	Insertion Loss (dB)	Attenuation (Absolute Value) (dB)	Isolation (min.) (dB)	Characteristic Impedance (Nom.) (ohm)	Power Capacity (W)	Application
LDC211G9518H-073	1950.0 ±30.0MHz	18.0 ±1.0dB	0.45 max. (at 25°C)	24.0 min. at 2x(f _o ±30.0)MHz	30.0	50	3 max. (50ohm Load)	UMTS(Band1)

Chip Multilayer Hybrid Couplers

3dB Hybrid

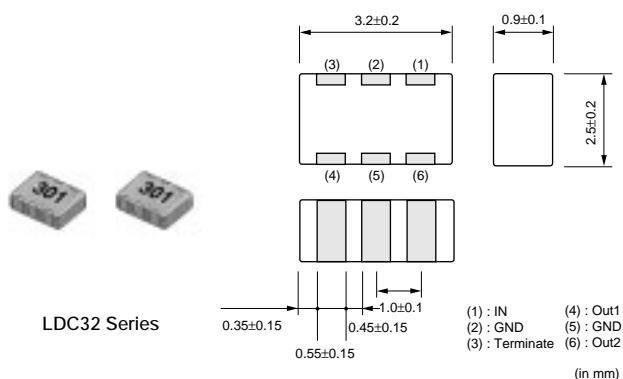

Part Number	Insertion Loss (dB)	Amplitude Balance (max.) (dB)	Phase Deviation (°)	Isolation (min.) (dB)	VSWR (max.)	Power Capacity (W)
LDC32900M03B-703	3.3 ±0.48dB	1.0	90 ±3.0°	20.5	1.43	3 max. (50ohm Load)

Characteristic Impedance: 50ohm Operating Temperature Range: -25°C to +85°C

Hybrid Dividers

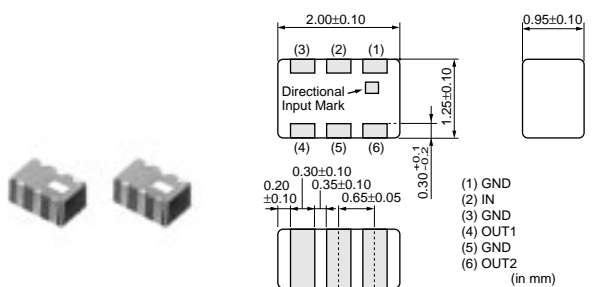

LDD21 Series

100ohm external resistor is required between Out 1 and Out 2.

All the technical data and information contained herein are subject to change without prior notice.

Part Number	Frequency Range (MHz)	Insertion Loss (OUT1,OUT2) (dB)	Isolation (min.) (dB)	VSWR (max.)	Application
LDD182G4503A-196	2450.0 ±50.0MHz	3.4 ±0.6dB	15.0	1.5	WLAN/BT
LDD211G7503A-067	1750.0 ±30.0MHz	3.4 ±0.4dB	20.0	1.5	CDMA
LDD212G1403A-075	2140.0 ±30.0MHz	3.4 ±0.4dB	22.0	1.5	UMTS(Band1)
LDD21967M03A-068	967.0 ±13.0MHz	3.4 ±0.4dB	20.0	1.4	CDMA

Characteristics Impedance (Nominal): 50ohm Operating Temperature Range: -40°C to +85°C

△Note • This PDF catalog is downloaded from the website of Murata Manufacturing co., ltd. Therefore, it's specifications are subject to change or our products in it may be discontinued without advance notice. Please check with our sales representatives or product engineers before ordering.
• This PDF catalog has only typical specifications because there is no space for detailed specifications. Therefore, please approve our product specifications or transact the approval sheet for product specifications before ordering.

Chip Multilayer Diplexers

LFD18_DP
3, 4, 5, 6 Series

(1) : GND
(2) : P1 (*1)
(3) : P3 (*2)
(4) : P2 (*3)

DP3.5 Type
(*1) Higher Frequency Port
(*2) Common Port
(*3) Lower Frequency Port

DP4.6 Type
(*1) Lower Frequency Port
(*2) Common Port
(*3) Higher Frequency Port

All the technical data and information contained herein are subject to change without prior notice. (in mm)

LFD21_DP
1, 2, 3, 4 Series

(*)1 Lower Frequency Port
(*)2 Higher Frequency Port
(*)3 Common Port
Terminal of "NC" should be fixed to the no connected pattern.

All the technical data and information contained herein are subject to change without prior notice. (in mm)

Part Number	Frequency Range (f1) (MHz)	Frequency Range (f2) (MHz)	Insertion Loss (I) (P1-P3 in f1) (dB)	Insertion Loss (II) (P2-P3 in f1) (dB)	Attenuation [P1-P3](in f2) (dB)	Attenuation [P2-P3](in f1) (dB)
LFD181G57DP5B910	2450 ±50.0MHz	1575.5 ±1.5MHz	0.8 max. (at 25°C)	0.65 max. (at 25°C)	20 min.	20 min.
LFD181G57DP6B913	1575.5 ±1.5MHz	2450 ±50.0MHz	0.65 max. (at 25°C)	0.80 max. (at 25°C)	20 min.	20 min.
LFD181G57DPFC087	2450 ±50.0MHz	1575 ±3.0MHz	0.5 max. (at 25°C)	0.35 max. (at 25°C)	22 min.	13 min.
LFD181G57DPGC092	1575 ±3.0MHz	2450 ±50.0MHz	0.35 max. (at 25°C)	0.5 max. (at 25°C)	13 min.	22 min.
LFD182G45DP3A299	5375 ±475.0MHz	2450 ±50.0MHz	0.60 max. (at 25°C)	0.40 max. (at 25°C)	20 min.	20 min.
LFD182G45DP3B888	5375 ±475.0MHz	2450 ±50.0MHz	0.60 max. (at 25°C)	0.40 max. (at 25°C)	20 min.	20 min.
LFD182G45DP4B720	5375 ±475.0MHz	2450 ±50.0MHz	0.40 max. (at 25°C)	0.60 max. (at 25°C)	20 min.	20 min.
LFD182G45DP4B889	5375 ±475.0MHz	2450 ±50.0MHz	0.40 max. (at 25°C)	0.60 max. (at 25°C)	20 min.	20 min.
LFD212G45DP3A140	5250 ±100.0MHz	2450 ±50.0MHz	0.65 max. (at 25°C)	0.50 max. (at 25°C)	20 min.	20 min.
LFD212G45DP3A151	5487.5 ±337.5MHz	2450 ±50.0MHz	0.75 max. (at 25°C)	0.50 max. (at 25°C)	20 min.	16 min.
LFD212G45DP3A188	5375 ±475.0MHz	2450 ±50.0MHz	0.75 max. (at 25°C)	0.50 max. (at 25°C)	21 min.	17 min.
LFD212G45DP4A189	2450 ±50.0MHz	5375 ±475.0MHz	0.5 max. (at 25°C)	0.75 max. (at 25°C)	17 min.	21 min.
LFD21859MDP1A049	1920 ±70.0MHz	859 ±35.0MHz	0.45 max. (at 25°C)	0.40 max. (at 25°C)	19 min.	20 min.
LFD21859MDP2A076	859 ±35.0MHz	1920 ±70.0MHz	0.40 max. (at 25°C)	0.45 max. (at 25°C)	20 min.	19 min.
LFD21874MDP1A084	1575.5 ±3.0MHz	874 ±51.0MHz	0.60 max. (at 25°C)	0.55 max. (at 25°C)	25 min.	23 min.
LFD21874MDP2A181	874 ±51.0MHz	1575.5 ±3.0MHz	0.55 max. (at 25°C)	0.60 max. (at 25°C)	23 min.	25 min.
LFD21884MDP1A062	1906.5 ±13.0MHz	884 ±74.0MHz	0.45 max. (at 25°C)	0.50 max. (at 25°C)	20 min.	20 min.
LFD21892MDP1A141	1850 ±140.0MHz	892 ±68.0MHz	0.60 max. (at 25°C)	0.40 max. (at 25°C)	19 min.	17 min.
LFD21892MDP2B860	892 ±68.0MHz	1850 ±140.0MHz	0.40 max. (at 25°C)	0.60 max. (at 25°C)	17 min.	19 min.
LFD21892MDPFC065	1940 ±230.0MHz	892 ±68.0MHz	0.45 max. (at 25°C)	0.27 max. (at 25°C)	19 min.	13 min.
LFD21892MDPGC103	892 ±68.0MHz	1940 ±230.0MHz	0.27 max. (at 25°C)	0.45 max. (at 25°C)	13 min.	19 min.
LFD21920MDP1A048	1795 ±85.0MHz	920 ±40.0MHz	0.55 max. (at 25°C)	0.50 max. (at 25°C)	20 min.	16 min.

8 Microwave Components

Chip Multilayer Hybrid Baluns

LDB18 Series

G Type
(1) : Unbalance port
(2)(5) : GND
(3)(4) : Balance port
(6) : NC

C Type
(1) : Unbalance port
(2)(5) : NC
(3) : GND
(4)(6) : Balance port

*Terminal of "NC" should be fixed to the no connected pattern.
All the technical data and information contained herein are subject to change without prior notice. (in mm)

LDB21 Series

(1) : Unbalance Port
(2)(5) : GND
(3)(4) : Balance Port
(6) : NC

* Terminal of "NC" should be connected to the floating land.
* All the technical data and information contained herein are subject to change without prior notice. in mm

Part Number	Frequency Range (MHz)	Insertion Loss I) (dB)	Insertion Loss II) (dB)	Unbalance Impedance (Nom.) (ohm)	Balance Impedance (Nom.) (ohm)	Application
LDB181G8115G-120	1810 ±100MHz	1.1 max. (at 25°C)	1.2 max. (-40~+85°C)	50	150	GSM
LDB181G8120G-120	1810 ±100MHz	1.2 max. (at 25°C)	1.3 max. (-40~+85°C)	50	200	GSM
LDB181G9505C-110	1955.0 ±35.0MHz	1.2 max. (at 25°C)	1.3 max. (-40~+85°C)	50	50	GSM
LDB181G9510C-110	1955.0 ±35.0MHz	1.2 max. (at 25°C)	1.3 max. (-40~+85°C)	50	100	GSM
LDB182G4505C-110	2450.0 ±50.0MHz	1.0 max. (at 25°C)	1.1 max. (-40~+85°C)	50	50	WLAN/BT
LDB182G4510C-110	2450.0 ±50.0MHz	1.0 max. (at 25°C)	1.1 max. (-40~+85°C)	50	100	WLAN/BT
LDB182G4510G-120	2450.0 ±50.0MHz	1.1 max. (at 25°C)	1.2 max. (-40~+85°C)	50	100	WLAN/BT
LDB182G4520C-110	2450.0 ±50.0MHz	1.3 max. (at 25°C)	1.4 max. (-40~+85°C)	50	200	WLAN/BT
LDB182G5005G-120	2500 ±200MHz	1.15 max. (at 25°C)	1.25 max. (-40~+85°C)	50	50	WIMAX
LDB182G5010G-120	2500 ±200MHz	1.1 max. (at 25°C)	1.2 max. (-40~+85°C)	50	100	WIMAX
LDB183G4505G-120	3450 ±150MHz	1.25 max. (at 25°C)	1.35 max. (-40~+85°C)	50	50	WIMAX
LDB183G4510G-120	3450 ±150MHz	1.25 max. (at 25°C)	1.35 max. (-40~+85°C)	50	100	WIMAX
LDB183G6005G-120	3600 ±300MHz	1.3 max. (at 25°C)	1.4 max. (-40~+85°C)	50	50	WIMAX
LDB183G6010G-120	3600 ±300MHz	1.4 max. (at 25°C)	1.5 max. (-40~+85°C)	50	100	WIMAX
LDB183G7010C-110	3700.0 ±300.0MHz	1.4 max. (at 25°C)	1.5 max. (-40~+85°C)	50	100	GSM
LDB184G5010C-110	4500.0 ±300.0MHz	1.1 max. (at 25°C)	1.2 max. (-40~+85°C)	50	100	GSM
LDB185G3705G-120	5375 ±475MHz	1.50 max. (at 25°C)	1.65 max. (-40~+85°C)	50	50	WLAN/BT
LDB185G3710G-120	5375 ±475MHz	1.20 max. (at 25°C)	1.35 max. (-40~+85°C)	50	100	WLAN/BT
LDB18869M10G-120	869.5 ±45.5MHz	1.0 max. (at 25°C)	1.1 max. (-40~+85°C)	50	100	GSM
LDB18869M15G-120	869.5 ±45.5MHz	1.0 max. (at 25°C)	1.1 max. (-40~+85°C)	50	150	GSM
LDB211G8105C-001	1815 ±105MHz	1.0 max. (at 25°C)	1.1 max. (-40~+85°C)	50	50	GSM
LDB211G8110C-001	1810 ±100MHz	0.8 max. (at 25°C)	0.9 max. (-40~+85°C)	50	100	GSM
LDB211G8115C-001	1810 ±100MHz	0.8 max. (at 25°C)	0.9 max. (-40~+85°C)	50	150	GSM
LDB211G8120C-002	1810 ±100MHz	0.8 max. (at 25°C)	0.9 max. (-40~+85°C)	50	200	GSM
LDB212G4005C-001	2400 ±100MHz	0.8 max. (at 25°C)	0.9 max. (-40~+85°C)	50	50	WLAN/BT
LDB212G4010C-001	2400 ±100MHz	0.9 max. (at 25°C)	1.0 max. (-40~+85°C)	50	100	WLAN/BT
LDB212G4020C-001	2400 ±100MHz	0.95 max. (at 25°C)	1.05 max. (-40~+85°C)	50	200	WLAN/BT
LDB213G7010C-002	3700 ±300MHz	1.0 max. (at 25°C)	1.1 max. (-40~+85°C)	50	100	GSM
LDB213G7020C-001	3700 ±300MHz	2.2 max. (at 25°C)	2.3 max. (-40~+85°C)	50	200	GSM
LDB215G1210C-001	5125 ±225MHz	1.10 max. (at 25°C)	1.25 max. (-40~+85°C)	50	100	WLAN/BT
LDB215G2505C-001	5250 ±100MHz	1.10 max. (at 25°C)	1.25 max. (-40~+85°C)	50	50	WLAN/BT
LDB215G2510C-001	5250 ±100MHz	0.95 max. (at 25°C)	1.10 max. (-40~+85°C)	50	100	WLAN/BT
LDB215G2520C-001	5250 ±100MHz	1.10 max. (at 25°C)	1.25 max. (-40~+85°C)	50	200	WLAN/BT
LDB215G3710C-001	5375 ±475MHz	0.95 max. (at 25°C)	1.10 max. (-40~+85°C)	50	100	WLAN/BT
LDB215G5105C-001	5512 ±363MHz	1.10 max. (at 25°C)	1.25 max. (-40~+85°C)	50	50	WLAN/BT
LDB215G5110C-001	5512 ±363MHz	0.95 max. (at 25°C)	1.10 max. (-40~+85°C)	50	100	WLAN/BT
LDB215G5120C-001	5512 ±363MHz	1.10 max. (at 25°C)	1.25 max. (-40~+85°C)	50	200	WLAN/BT
LDB21869M10C-001	869.5 ±45.5MHz	1.0 max. (at 25°C)	1.1 max. (-40~+85°C)	50	100	GSM
LDB21869M15C-001	869.5 ±45.5MHz	1.2 max. (at 25°C)	1.3 max. (-40~+85°C)	50	150	GSM
LDB21869M20C-001	869.5 ±45.5MHz	1.2 max. (at 25°C)	1.3 max. (-40~+85°C)	50	200	GSM
LDB21881M05C-001	881.5 ±12.5MHz	1.4 max. (at 25°C)	1.5 max. (-40~+85°C)	50	50	GSM
LDB21881M20C-001	881.5 ±12.5MHz	1.4 max. (at 25°C)	1.5 max. (-40~+85°C)	50	200	GSM
LDB21942M05C-001	942.5 ±17.5MHz	1.4 max. (at 25°C)	1.5 max. (-40~+85°C)	50	50	GSM
LDB21942M20C-001	942.5 ±17.5MHz	1.3 max. (at 25°C)	1.4 max. (-40~+85°C)	50	200	GSM
LDM182G4505CC001	2450 ±50MHz	0.88 max. (at 25°C)	0.98 max. (-40~+85°C)	50	50	WLAN/BT
LDM182G4510CC001	2450 ±50MHz	0.75 max. (at 25°C)	0.85 max. (-40~+85°C)	50	100	WLAN/BT
LDM182G5005CC001	2500 ±200MHz	0.9 max. (at 25°C)	1.0 max. (-40~+85°C)	50	50	WLAN/BT

Chip Antennas

Chip Antennas

● LDA Series



LDA2H2G6540G-254

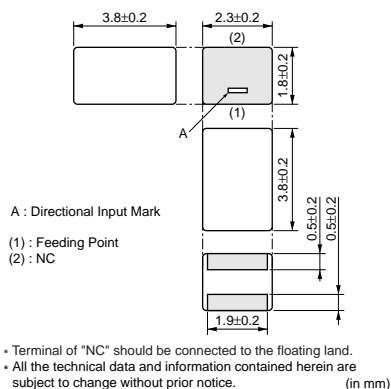

LDA312G7313F-237

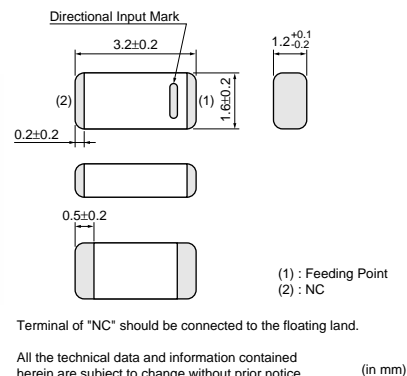

LDA212G3110K-282

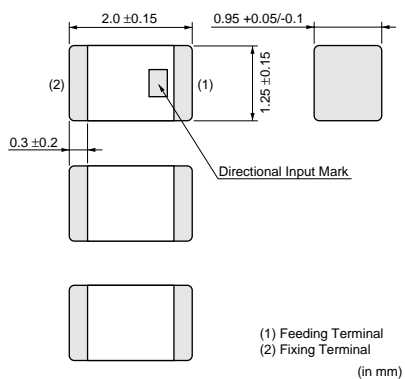

Part Number	Fo (MHz)	Bandwidth	VSWR (max.)
LDA212G3110K-282	2330	-	-
LDA212G4410K-283	2460	-	-
LDA212G6310K-284	2630	-	-
LDA212G8610K-285	2860	-	-
LDA213G1610K-286	3160	-	-
LDA2H2G6540G-254	2650	-	-
LDA312G4413H-280	2442	-	-
LDA312G7313F-237	2730	-	-
LDA313G0313F-240	3030	-	-
LDA313G3313F-243	3330	-	-
LDA315G2013F-246	5200	-	-
LDA316G2013F-250	6200	-	-

Note • This PDF catalog is downloaded from the website of Murata Manufacturing co., Ltd. Therefore, it's specifications are subject to change or our products in it may be discontinued without advance notice. Please check with our sales representatives or product engineers before ordering.
• This PDF catalog has only typical specifications because there is no space for detailed specifications. Therefore, please approve our product specifications or transact the approval sheet for product specifications before ordering.

● ANC Series

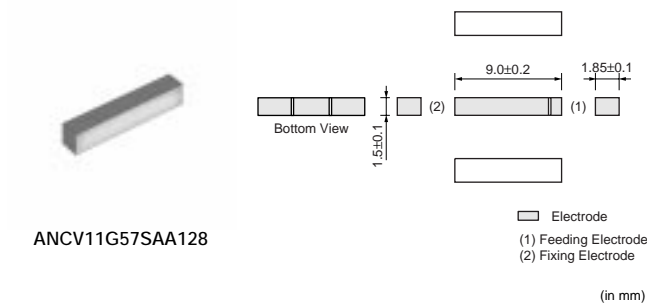
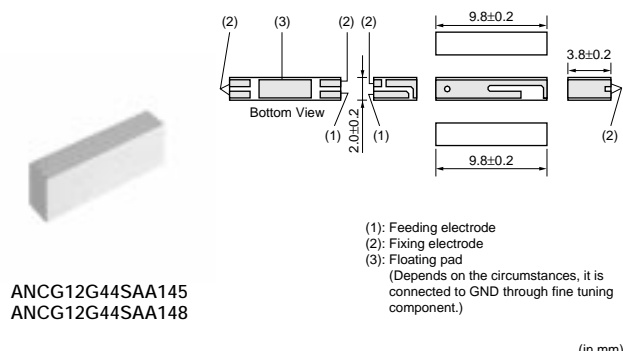
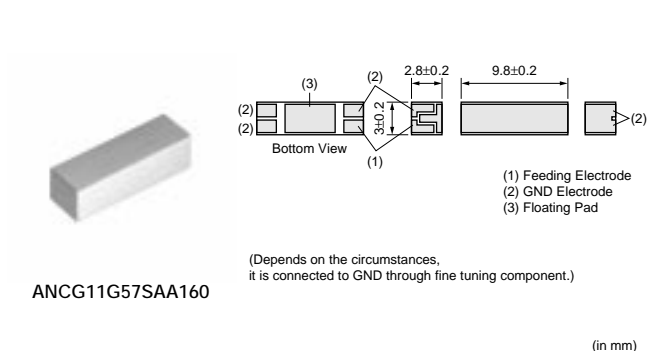
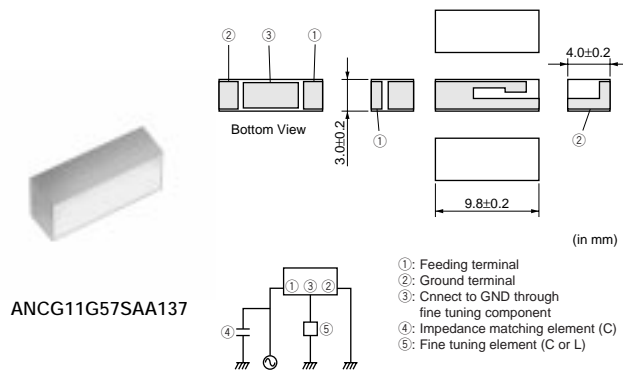
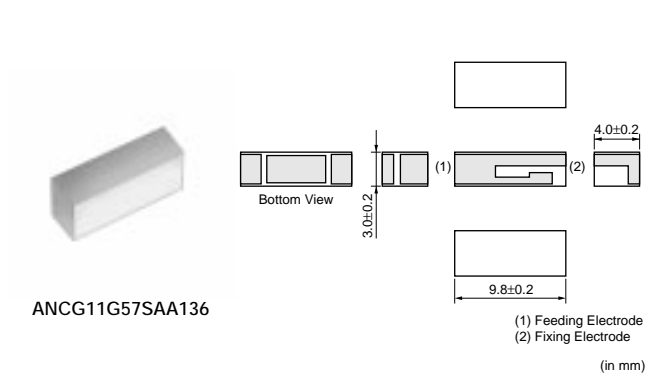

Part Number	Fo (MHz)	Bandwidth (MHz)	VSWR (max.)
ANC11G57SAA136	1575	2	3.0
ANC11G57SAA137	1575	2	3.0
ANC11G57SAA146	1575	2	3.5
ANC11G57SAA160	1575	2	3.5
ANC12G44SAA145	2442	84	4.0
ANC12G44SAA148	2442	84	4.0
ANCV11G57SAA128	1575	2	3.0
ANCV11G57SAA144	1575	2	3.5

ANC11G series are available on ground plane. Please contact us for detail specifications.

△Note • This PDF catalog is downloaded from the website of Murata Manufacturing co., ltd. Therefore, it's specifications are subject to change or our products in it may be discontinued without advance notice. Please check with our sales representatives or product engineers before ordering.
• This PDF catalog has only typical specifications because there is no space for detailed specifications. Therefore, please approve our product specifications or transact the approval sheet for product specifications before ordering.

High Frequency Monolithic Ceramic Capacitors

High Frequency High-Q/Low ESR Type GQM Series

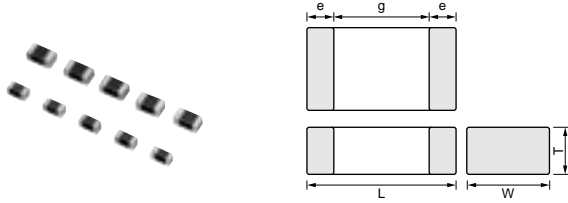

Part Number	Dimensions (mm)				
	L	W	T	e	g min.
GQM187	1.6 ±0.15	0.8 ±0.15	0.7 ±0.1	0.2 to 0.5	0.5
GQM188	1.6 ±0.1	0.8 ±0.1	0.8 ±0.1	0.2 to 0.5	0.5
GQM219 (50,100V)	2.0 ±0.1	1.25 ±0.1	0.85 ±0.1	0.2 to 0.7	0.7
GQM219 (250V)	2.0 ±0.15	1.25 ±0.15	0.85 ±0.15	0.2 to 0.7	0.7

● Temperature Compensating Type C0G(5C) Characteristics

LxW [mm]		1.6x0.8(18)<0603>	
Rated Volt. [Vdc]		250(2E)	100(2A)
Capacitance	Tolerance	Part Number	
0.10pF(R10)	±0.1pF(B)	GQM1875C2ER10BB12D	
0.20pF(R20)	±0.1pF(B)	GQM1875C2ER20BB12D	
0.30pF(R30)	±0.1pF(B)	GQM1875C2ER30BB12D	
	±0.25pF(C)	GQM1875C2ER30CB12D	
0.40pF(R40)	±0.1pF(B)	GQM1875C2ER40BB12D	
	±0.25pF(C)	GQM1875C2ER40CB12D	
0.50pF(R50)	±0.1pF(B)	GQM1875C2ER50BB12D	GQM1885C2AR50BB01D
	±0.25pF(C)	GQM1875C2ER50CB12D	GQM1885C2AR50CB01D
0.75pF(R75)	±0.1pF(B)	GQM1875C2ER75BB12D	GQM1885C2AR75BB01D
	±0.25pF(C)	GQM1875C2ER75CB12D	GQM1885C2AR75CB01D
1.0pF(1R0)	±0.1pF(B)	GQM1875C2E1R0BB12D	GQM1885C2A1R0BB01D
	±0.25pF(C)	GQM1875C2E1R0CB12D	GQM1885C2A1R0CB01D
1.1pF(1R1)	±0.1pF(B)	GQM1875C2E1R1BB12D	GQM1885C2A1R1BB01D
	±0.25pF(C)	GQM1875C2E1R1CB12D	GQM1885C2A1R1CB01D
1.2pF(1R2)	±0.1pF(B)	GQM1875C2E1R2BB12D	GQM1885C2A1R2BB01D
	±0.25pF(C)	GQM1875C2E1R2CB12D	GQM1885C2A1R2CB01D
1.3pF(1R3)	±0.1pF(B)	GQM1875C2E1R3BB12D	GQM1885C2A1R3BB01D
	±0.25pF(C)	GQM1875C2E1R3CB12D	GQM1885C2A1R3CB01D
1.5pF(1R5)	±0.1pF(B)	GQM1875C2E1R5BB12D	GQM1885C2A1R5BB01D
	±0.25pF(C)	GQM1875C2E1R5CB12D	GQM1885C2A1R5CB01D
1.6pF(1R6)	±0.1pF(B)	GQM1875C2E1R6BB12D	GQM1885C2A1R6BB01D
	±0.25pF(C)	GQM1875C2E1R6CB12D	GQM1885C2A1R6CB01D
1.8pF(1R8)	±0.1pF(B)	GQM1875C2E1R8BB12D	GQM1885C2A1R8BB01D
	±0.25pF(C)	GQM1875C2E1R8CB12D	GQM1885C2A1R8CB01D
2.0pF(2R0)	±0.1pF(B)	GQM1875C2E2R0BB12D	GQM1885C2A2R0BB01D
	±0.25pF(C)	GQM1875C2E2R0CB12D	GQM1885C2A2R0CB01D
2.2pF(2R2)	±0.1pF(B)	GQM1875C2E2R2BB12D	GQM1885C2A2R2BB01D
	±0.25pF(C)	GQM1875C2E2R2CB12D	GQM1885C2A2R2CB01D
2.4pF(2R4)	±0.1pF(B)	GQM1875C2E2R4BB12D	GQM1885C2A2R4BB01D
	±0.25pF(C)	GQM1875C2E2R4CB12D	GQM1885C2A2R4CB01D
2.7pF(2R7)	±0.1pF(B)	GQM1875C2E2R7BB12D	GQM1885C2A2R7BB01D
	±0.25pF(C)	GQM1875C2E2R7CB12D	GQM1885C2A2R7CB01D
3.0pF(3R0)	±0.1pF(B)	GQM1875C2E3R0BB12D	GQM1885C2A3R0BB01D
	±0.25pF(C)	GQM1875C2E3R0CB12D	GQM1885C2A3R0CB01D
3.3pF(3R3)	±0.1pF(B)	GQM1875C2E3R3BB12D	GQM1885C2A3R3BB01D
	±0.25pF(C)	GQM1875C2E3R3CB12D	GQM1885C2A3R3CB01D
3.6pF(3R6)	±0.1pF(B)	GQM1875C2E3R6BB12D	GQM1885C2A3R6BB01D
	±0.25pF(C)	GQM1875C2E3R6CB12D	GQM1885C2A3R6CB01D
3.9pF(3R9)	±0.1pF(B)	GQM1875C2E3R9BB12D	GQM1885C2A3R9BB01D
	±0.25pF(C)	GQM1875C2E3R9CB12D	GQM1885C2A3R9CB01D
4.0pF(4R0)	±0.1pF(B)	GQM1875C2E4R0BB12D	GQM1885C2A4R0BB01D
	±0.25pF(C)	GQM1875C2E4R0CB12D	GQM1885C2A4R0CB01D
4.3pF(4R3)	±0.1pF(B)	GQM1875C2E4R3BB12D	GQM1885C2A4R3BB01D
	±0.25pF(C)	GQM1875C2E4R3CB12D	GQM1885C2A4R3CB01D
4.7pF(4R7)	±0.1pF(B)	GQM1875C2E4R7BB12D	GQM1885C2A4R7BB01D
	±0.25pF(C)	GQM1875C2E4R7CB12D	GQM1885C2A4R7CB01D
5.0pF(5R0)	±0.1pF(B)	GQM1875C2E5R0BB12D	GQM1885C2A5R0BB01D
	±0.25pF(C)	GQM1875C2E5R0CB12D	GQM1885C2A5R0CB01D

The part number code is shown in () and Unit is shown in []. < >: EIA [inch] Code

● Temperature Compensating Type C0G(5C) Characteristics

LxW [mm]		1.6x0.8(18)<0603>		
Rated Volt. [Vdc]		250(2E)	100(2A)	50(1H)
Capacitance	Tolerance	Part Number		
5.1pF(5R1)	±0.25pF(C)	GQM1875C2E5R1CB12D	GQM1885C2A5R1CB01D	
	±0.5pF(D)	GQM1875C2E5R1DB12D	GQM1885C2A5R1DB01D	
5.6pF(5R6)	±0.25pF(C)	GQM1875C2E5R6CB12D	GQM1885C2A5R6CB01D	
	±0.5pF(D)	GQM1875C2E5R6DB12D	GQM1885C2A5R6DB01D	
6.0pF(6R0)	±0.25pF(C)	GQM1875C2E6R0CB12D	GQM1885C2A6R0CB01D	
	±0.5pF(D)	GQM1875C2E6R0DB12D	GQM1885C2A6R0DB01D	
6.2pF(6R2)	±0.25pF(C)	GQM1875C2E6R2CB12D	GQM1885C2A6R2CB01D	
	±0.5pF(D)	GQM1875C2E6R2DB12D	GQM1885C2A6R2DB01D	
6.8pF(6R8)	±0.25pF(C)	GQM1875C2E6R8CB12D	GQM1885C2A6R8CB01D	
	±0.5pF(D)	GQM1875C2E6R8DB12D	GQM1885C2A6R8DB01D	
7.0pF(7R0)	±0.25pF(C)	GQM1875C2E7R0CB12D		GQM1885C1H7R0CB01D
	±0.5pF(D)	GQM1875C2E7R0DB12D		GQM1885C1H7R0DB01D
7.5pF(7R5)	±0.25pF(C)	GQM1875C2E7R5CB12D		GQM1885C1H7R5CB01D
	±0.5pF(D)	GQM1875C2E7R5DB12D		GQM1885C1H7R5DB01D
8.0pF(8R0)	±0.25pF(C)	GQM1875C2E8R0CB12D		GQM1885C1H8R0CB01D
	±0.5pF(D)	GQM1875C2E8R0DB12D		GQM1885C1H8R0DB01D
8.2pF(8R2)	±0.25pF(C)	GQM1875C2E8R2CB12D		GQM1885C1H8R2CB01D
	±0.5pF(D)	GQM1875C2E8R2DB12D		GQM1885C1H8R2DB01D
9.0pF(9R0)	±0.25pF(C)	GQM1875C2E9R0CB12D		GQM1885C1H9R0CB01D
	±0.5pF(D)	GQM1875C2E9R0DB12D		GQM1885C1H9R0DB01D
9.1pF(9R1)	±0.25pF(C)	GQM1875C2E9R1CB12D		GQM1885C1H9R1CB01D
	±0.5pF(D)	GQM1875C2E9R1DB12D		GQM1885C1H9R1DB01D
10pF(100)	±2%(G)	GQM1875C2E100GB12D		GQM1885C1H100GB01D
	±5%(J)	GQM1875C2E100JB12D		GQM1885C1H100JB01D
11pF(110)	±2%(G)	GQM1875C2E110GB12D		GQM1885C1H110GB01D
	±5%(J)	GQM1875C2E110JB12D		GQM1885C1H110JB01D
12pF(120)	±2%(G)	GQM1875C2E120GB12D		GQM1885C1H120GB01D
	±5%(J)	GQM1875C2E120JB12D		GQM1885C1H120JB01D
13pF(130)	±2%(G)	GQM1875C2E130GB12D		GQM1885C1H130GB01D
	±5%(J)	GQM1875C2E130JB12D		GQM1885C1H130JB01D
15pF(150)	±2%(G)	GQM1875C2E150GB12D		GQM1885C1H150GB01D
	±5%(J)	GQM1875C2E150JB12D		GQM1885C1H150JB01D
16pF(160)	±2%(G)	GQM1875C2E160GB12D		GQM1885C1H160GB01D
	±5%(J)	GQM1875C2E160JB12D		GQM1885C1H160JB01D
18pF(180)	±2%(G)	GQM1875C2E180GB12D		GQM1885C1H180GB01D
	±5%(J)	GQM1875C2E180JB12D		GQM1885C1H180JB01D
20pF(200)	±2%(G)	GQM1875C2E200GB12D		GQM1885C1H200GB01D
	±5%(J)	GQM1875C2E200JB12D		GQM1885C1H200JB01D
22pF(220)	±2%(G)	GQM1875C2E220GB12D		GQM1885C1H220GB01D
	±5%(J)	GQM1875C2E220JB12D		GQM1885C1H220JB01D
24pF(240)	±2%(G)	GQM1875C2E240GB12D		GQM1885C1H240GB01D
	±5%(J)	GQM1875C2E240JB12D		GQM1885C1H240JB01D
27pF(270)	±2%(G)	GQM1875C2E270GB12D		GQM1885C1H270GB01D
	±5%(J)	GQM1875C2E270JB12D		GQM1885C1H270JB01D
30pF(300)	±2%(G)	GQM1875C2E300GB12D		GQM1885C1H300GB01D
	±5%(J)	GQM1875C2E300JB12D		GQM1885C1H300JB01D

The part number code is shown in () and Unit is shown in []. < >: EIA [inch] Code

● Temperature Compensating Type C0G(5C) Characteristics

LxW [mm]		1.6x0.8(18)<0603>	
Rated Volt. [Vdc]		250(2E)	50(1H)
Capacitance	Tolerance	Part Number	
33pF(330)	±2%(G)	GQM1875C2E330GB12D	GQM1885C1H330GB01D
	±5%(J)	GQM1875C2E330JB12D	GQM1885C1H330JB01D
36pF(360)	±2%(G)	GQM1875C2E360GB12D	GQM1885C1H360GB01D
	±5%(J)	GQM1875C2E360JB12D	GQM1885C1H360JB01D
39pF(390)	±2%(G)	GQM1875C2E390GB12D	GQM1885C1H390GB01D
	±5%(J)	GQM1875C2E390JB12D	GQM1885C1H390JB01D
43pF(430)	±2%(G)	GQM1875C2E430GB12D	GQM1885C1H430GB01D
	±5%(J)	GQM1875C2E430JB12D	GQM1885C1H430JB01D
47pF(470)	±2%(G)	GQM1875C2E470GB12D	GQM1885C1H470GB01D
	±5%(J)	GQM1875C2E470JB12D	GQM1885C1H470JB01D
51pF(510)	±2%(G)		GQM1885C1H510GB01D
	±5%(J)		GQM1885C1H510JB01D
56pF(560)	±2%(G)		GQM1885C1H560GB01D
	±5%(J)		GQM1885C1H560JB01D
62pF(620)	±2%(G)		GQM1885C1H620GB01D
	±5%(J)		GQM1885C1H620JB01D
68pF(680)	±2%(G)		GQM1885C1H680GB01D
	±5%(J)		GQM1885C1H680JB01D
75pF(750)	±2%(G)		GQM1885C1H750GB01D
	±5%(J)		GQM1885C1H750JB01D
82pF(820)	±2%(G)		GQM1885C1H820GB01D
	±5%(J)		GQM1885C1H820JB01D
91pF(910)	±2%(G)		GQM1885C1H910GB01D
	±5%(J)		GQM1885C1H910JB01D
100pF(101)	±2%(G)		GQM1885C1H101GB01D
	±5%(J)		GQM1885C1H101JB01D

The part number code is shown in () and Unit is shown in []. < >: EIA [inch] Code

● Temperature Compensating Type C0G(5C) Characteristics

LxW [mm]		2.0x1.25(21)<0805>	
Rated Volt. [Vdc]		250(2E)	100(2A)
Capacitance	Tolerance	Part Number	
0.50pF(50)	±0.1pF(B)	GQM2195C2ER50BB12D	GQM2195C2AR50BB01D
	±0.25pF(C)	GQM2195C2ER50CB12D	GQM2195C2AR50CB01D
0.75pF(75)	±0.1pF(B)	GQM2195C2ER75BB12D	GQM2195C2AR75BB01D
	±0.25pF(C)	GQM2195C2ER75CB12D	GQM2195C2AR75CB01D
1.0pF(10)	±0.1pF(B)	GQM2195C2E1R0BB12D	GQM2195C2A1R0BB01D
	±0.25pF(C)	GQM2195C2E1R0CB12D	GQM2195C2A1R0CB01D
1.1pF(11)	±0.1pF(B)	GQM2195C2E1R1BB12D	GQM2195C2A1R1BB01D
	±0.25pF(C)	GQM2195C2E1R1CB12D	GQM2195C2A1R1CB01D
1.2pF(12)	±0.1pF(B)	GQM2195C2E1R2BB12D	GQM2195C2A1R2BB01D
	±0.25pF(C)	GQM2195C2E1R2CB12D	GQM2195C2A1R2CB01D
1.3pF(13)	±0.1pF(B)	GQM2195C2E1R3BB12D	GQM2195C2A1R3BB01D
	±0.25pF(C)	GQM2195C2E1R3CB12D	GQM2195C2A1R3CB01D
1.5pF(15)	±0.1pF(B)	GQM2195C2E1R5BB12D	GQM2195C2A1R5BB01D
	±0.25pF(C)	GQM2195C2E1R5CB12D	GQM2195C2A1R5CB01D
1.6pF(16)	±0.1pF(B)	GQM2195C2E1R6BB12D	GQM2195C2A1R6BB01D
	±0.25pF(C)	GQM2195C2E1R6CB12D	GQM2195C2A1R6CB01D
1.8pF(18)	±0.1pF(B)	GQM2195C2E1R8BB12D	GQM2195C2A1R8BB01D
	±0.25pF(C)	GQM2195C2E1R8CB12D	GQM2195C2A1R8CB01D
2.0pF(20)	±0.1pF(B)	GQM2195C2E2R0BB12D	GQM2195C2A2R0BB01D
	±0.25pF(C)	GQM2195C2E2R0CB12D	GQM2195C2A2R0CB01D
2.2pF(22)	±0.1pF(B)	GQM2195C2E2R2BB12D	GQM2195C2A2R2BB01D
	±0.25pF(C)	GQM2195C2E2R2CB12D	GQM2195C2A2R2CB01D
2.4pF(24)	±0.1pF(B)	GQM2195C2E2R4BB12D	GQM2195C2A2R4BB01D
	±0.25pF(C)	GQM2195C2E2R4CB12D	GQM2195C2A2R4CB01D
2.7pF(27)	±0.1pF(B)	GQM2195C2E2R7BB12D	GQM2195C2A2R7BB01D
	±0.25pF(C)	GQM2195C2E2R7CB12D	GQM2195C2A2R7CB01D
3.0pF(30)	±0.1pF(B)	GQM2195C2E3R0BB12D	GQM2195C2A3R0BB01D
	±0.25pF(C)	GQM2195C2E3R0CB12D	GQM2195C2A3R0CB01D
3.3pF(33)	±0.1pF(B)	GQM2195C2E3R3BB12D	GQM2195C2A3R3BB01D
	±0.25pF(C)	GQM2195C2E3R3CB12D	GQM2195C2A3R3CB01D
3.6pF(36)	±0.1pF(B)	GQM2195C2E3R6BB12D	GQM2195C2A3R6BB01D
	±0.25pF(C)	GQM2195C2E3R6CB12D	GQM2195C2A3R6CB01D
3.9pF(39)	±0.1pF(B)	GQM2195C2E3R9BB12D	GQM2195C2A3R9BB01D
	±0.25pF(C)	GQM2195C2E3R9CB12D	GQM2195C2A3R9CB01D
4.0pF(40)	±0.1pF(B)	GQM2195C2E4R0BB12D	GQM2195C2A4R0BB01D
	±0.25pF(C)	GQM2195C2E4R0CB12D	GQM2195C2A4R0CB01D
4.3pF(43)	±0.1pF(B)	GQM2195C2E4R3BB12D	GQM2195C2A4R3BB01D
	±0.25pF(C)	GQM2195C2E4R3CB12D	GQM2195C2A4R3CB01D
4.7pF(47)	±0.1pF(B)	GQM2195C2E4R7BB12D	GQM2195C2A4R7BB01D
	±0.25pF(C)	GQM2195C2E4R7CB12D	GQM2195C2A4R7CB01D
5.0pF(50)	±0.1pF(B)	GQM2195C2E5R0BB12D	GQM2195C2A5R0BB01D
	±0.25pF(C)	GQM2195C2E5R0CB12D	GQM2195C2A5R0CB01D
5.1pF(51)	±0.25pF(C)	GQM2195C2E5R1CB12D	GQM2195C2A5R1CB01D
	±0.5pF(D)	GQM2195C2E5R1DB12D	GQM2195C2A5R1DB01D
5.6pF(56)	±0.25pF(C)	GQM2195C2E5R6CB12D	GQM2195C2A5R6CB01D
	±0.5pF(D)	GQM2195C2E5R6DB12D	GQM2195C2A5R6DB01D
6.0pF(60)	±0.25pF(C)	GQM2195C2E6R0CB12D	GQM2195C2A6R0CB01D
	±0.5pF(D)	GQM2195C2E6R0DB12D	GQM2195C2A6R0DB01D

The part number code is shown in () and Unit is shown in []. < >: EIA [inch] Code

● Temperature Compensating Type C0G(5C) Characteristics

LxW [mm]		2.0x1.25(21)<0805>		
Rated Volt. [Vdc]		250(2E)	100(2A)	50(1H)
Capacitance	Tolerance	Part Number		
6.2pF(6R2)	±0.25pF(C)	GQM2195C2E6R2CB12D	GQM2195C2A6R2CB01D	
	±0.5pF(D)	GQM2195C2E6R2DB12D	GQM2195C2A6R2DB01D	
6.8pF(6R8)	±0.25pF(C)	GQM2195C2E6R8CB12D	GQM2195C2A6R8CB01D	
	±0.5pF(D)	GQM2195C2E6R8DB12D	GQM2195C2A6R8DB01D	
7.0pF(7R0)	±0.25pF(C)	GQM2195C2E7R0CB12D	GQM2195C2A7R0CB01D	
	±0.5pF(D)	GQM2195C2E7R0DB12D	GQM2195C2A7R0DB01D	
7.5pF(7R5)	±0.25pF(C)	GQM2195C2E7R5CB12D	GQM2195C2A7R5CB01D	
	±0.5pF(D)	GQM2195C2E7R5DB12D	GQM2195C2A7R5DB01D	
8.0pF(8R0)	±0.25pF(C)	GQM2195C2E8R0CB12D	GQM2195C2A8R0CB01D	
	±0.5pF(D)	GQM2195C2E8R0DB12D	GQM2195C2A8R0DB01D	
8.2pF(8R2)	±0.25pF(C)	GQM2195C2E8R2CB12D	GQM2195C2A8R2CB01D	
	±0.5pF(D)	GQM2195C2E8R2DB12D	GQM2195C2A8R2DB01D	
9.0pF(9R0)	±0.25pF(C)	GQM2195C2E9R0CB12D	GQM2195C2A9R0CB01D	
	±0.5pF(D)	GQM2195C2E9R0DB12D	GQM2195C2A9R0DB01D	
9.1pF(9R1)	±0.25pF(C)	GQM2195C2E9R1CB12D	GQM2195C2A9R1CB01D	
	±0.5pF(D)	GQM2195C2E9R1DB12D	GQM2195C2A9R1DB01D	
10pF(100)	±2%(G)	GQM2195C2E100GB12D	GQM2195C2A100GB01D	
	±5%(J)	GQM2195C2E100JB12D	GQM2195C2A100JB01D	
11pF(110)	±2%(G)	GQM2195C2E110GB12D	GQM2195C2A110GB01D	
	±5%(J)	GQM2195C2E110JB12D	GQM2195C2A110JB01D	
12pF(120)	±2%(G)	GQM2195C2E120GB12D	GQM2195C2A120GB01D	
	±5%(J)	GQM2195C2E120JB12D	GQM2195C2A120JB01D	
13pF(130)	±2%(G)	GQM2195C2E130GB12D	GQM2195C2A130GB01D	
	±5%(J)	GQM2195C2E130JB12D	GQM2195C2A130JB01D	
15pF(150)	±2%(G)	GQM2195C2E150GB12D	GQM2195C2A150GB01D	
	±5%(J)	GQM2195C2E150JB12D	GQM2195C2A150JB01D	
16pF(160)	±2%(G)	GQM2195C2E160GB12D	GQM2195C2A160GB01D	
	±5%(J)	GQM2195C2E160JB12D	GQM2195C2A160JB01D	
18pF(180)	±2%(G)	GQM2195C2E180GB12D	GQM2195C2A180GB01D	
	±5%(J)	GQM2195C2E180JB12D	GQM2195C2A180JB01D	
20pF(200)	±2%(G)	GQM2195C2E200GB12D		GQM2195C1H200GB01D
	±5%(J)	GQM2195C2E200JB12D		GQM2195C1H200JB01D
22pF(220)	±2%(G)	GQM2195C2E220GB12D		GQM2195C1H220GB01D
	±5%(J)	GQM2195C2E220JB12D		GQM2195C1H220JB01D
24pF(240)	±2%(G)	GQM2195C2E240GB12D		GQM2195C1H240GB01D
	±5%(J)	GQM2195C2E240JB12D		GQM2195C1H240JB01D
27pF(270)	±2%(G)	GQM2195C2E270GB12D		GQM2195C1H270GB01D
	±5%(J)	GQM2195C2E270JB12D		GQM2195C1H270JB01D
30pF(300)	±2%(G)	GQM2195C2E300GB12D		GQM2195C1H300GB01D
	±5%(J)	GQM2195C2E300JB12D		GQM2195C1H300JB01D
33pF(330)	±2%(G)	GQM2195C2E330GB12D		GQM2195C1H330GB01D
	±5%(J)	GQM2195C2E330JB12D		GQM2195C1H330JB01D
36pF(360)	±2%(G)	GQM2195C2E360GB12D		GQM2195C1H360GB01D
	±5%(J)	GQM2195C2E360JB12D		GQM2195C1H360JB01D
39pF(390)	±2%(G)	GQM2195C2E390GB12D		GQM2195C1H390GB01D
	±5%(J)	GQM2195C2E390JB12D		GQM2195C1H390JB01D

The part number code is shown in () and Unit is shown in []. < >: EIA [inch] Code

● Temperature Compensating Type C0G(5C) Characteristics

LxW [mm]		2.0x1.25(21)<0805>	
Rated Volt. [Vdc]		250(2E)	50(1H)
Capacitance	Tolerance	Part Number	
43pF(430)	±2%(G)	GQM2195C2E430GB12D	GQM2195C1H430GB01D
	±5%(J)	GQM2195C2E430JB12D	GQM2195C1H430JB01D
47pF(470)	±2%(G)	GQM2195C2E470GB12D	GQM2195C1H470GB01D
	±5%(J)	GQM2195C2E470JB12D	GQM2195C1H470JB01D
51pF(510)	±2%(G)	GQM2195C2E510GB12D	GQM2195C1H510GB01D
	±5%(J)	GQM2195C2E510JB12D	GQM2195C1H510JB01D
56pF(560)	±2%(G)	GQM2195C2E560GB12D	GQM2195C1H560GB01D
	±5%(J)	GQM2195C2E560JB12D	GQM2195C1H560JB01D
62pF(620)	±2%(G)	GQM2195C2E620GB12D	GQM2195C1H620GB01D
	±5%(J)	GQM2195C2E620JB12D	GQM2195C1H620JB01D
68pF(680)	±2%(G)	GQM2195C2E680GB12D	GQM2195C1H680GB01D
	±5%(J)	GQM2195C2E680JB12D	GQM2195C1H680JB01D
75pF(750)	±2%(G)	GQM2195C2E750GB12D	GQM2195C1H750GB01D
	±5%(J)	GQM2195C2E750JB12D	GQM2195C1H750JB01D
82pF(820)	±2%(G)	GQM2195C2E820GB12D	GQM2195C1H820GB01D
	±5%(J)	GQM2195C2E820JB12D	GQM2195C1H820JB01D
91pF(910)	±2%(G)	GQM2195C2E910GB12D	GQM2195C1H910GB01D
	±5%(J)	GQM2195C2E910JB12D	GQM2195C1H910JB01D
100pF(101)	±2%(G)	GQM2195C2E101GB12D	GQM2195C1H101GB01D
	±5%(J)	GQM2195C2E101JB12D	GQM2195C1H101JB01D

The part number code is shown in () and Unit is shown in []. < >: EIA [inch] Code

High Frequency Monolithic Ceramic Capacitors

High Frequency Type ERB Series

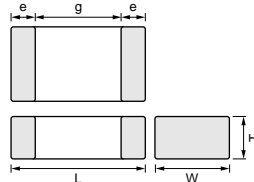

Part Number	Dimensions (mm)				
	L	W	T max.	e min.	g min.
ERB188	1.6±0.1	0.8±0.1	0.9	0.2	0.5
ERB21B	2.0±0.3	1.25±0.3	1.35	0.25	0.7
ERB32Q	3.2±0.3	2.5±0.3	1.7	0.3	1.0

● Temperature Compensating Type C0G(5C) Characteristics

LxW [mm]		1.6x0.8(18)<0603>	2.0x1.25(21)<0805>
Rated Volt. [Vdc]		250(2E)	250(2E)
Capacitance	Tolerance	Part Number	
0.50pF(1R50)	±0.1pF(B)	ERB1885C2ER50BDX1D	ERB21B5C2ER50BDX1L
	±0.25pF(C)	ERB1885C2ER50CDX1D	ERB21B5C2ER50CDX1L
0.75pF(1R75)	±0.1pF(B)	ERB1885C2ER75BDX1D	ERB21B5C2ER75BDX1L
	±0.25pF(C)	ERB1885C2ER75CDX1D	ERB21B5C2ER75CDX1L
1.0pF(1R0)	±0.1pF(B)	ERB1885C2E1R0BDX1D	ERB21B5C2E1R0BDX1L
	±0.25pF(C)	ERB1885C2E1R0CDX1D	ERB21B5C2E1R0CDX1L
1.1pF(1R1)	±0.1pF(B)	ERB1885C2E1R1BDX1D	ERB21B5C2E1R1BDX1L
	±0.25pF(C)	ERB1885C2E1R1CDX1D	ERB21B5C2E1R1CDX1L
1.2pF(1R2)	±0.1pF(B)	ERB1885C2E1R2BDX1D	ERB21B5C2E1R2BDX1L
	±0.25pF(C)	ERB1885C2E1R2CDX1D	ERB21B5C2E1R2CDX1L
1.3pF(1R3)	±0.1pF(B)	ERB1885C2E1R3BDX1D	ERB21B5C2E1R3BDX1L
	±0.25pF(C)	ERB1885C2E1R3CDX1D	ERB21B5C2E1R3CDX1L
1.5pF(1R5)	±0.1pF(B)	ERB1885C2E1R5BDX1D	ERB21B5C2E1R5BDX1L
	±0.25pF(C)	ERB1885C2E1R5CDX1D	ERB21B5C2E1R5CDX1L
1.6pF(1R6)	±0.1pF(B)	ERB1885C2E1R6BDX1D	ERB21B5C2E1R6BDX1L
	±0.25pF(C)	ERB1885C2E1R6CDX1D	ERB21B5C2E1R6CDX1L
1.8pF(1R8)	±0.1pF(B)	ERB1885C2E1R8BDX1D	ERB21B5C2E1R8BDX1L
	±0.25pF(C)	ERB1885C2E1R8CDX1D	ERB21B5C2E1R8CDX1L
2.0pF(2R0)	±0.1pF(B)	ERB1885C2E2R0BDX1D	ERB21B5C2E2R0BDX1L
	±0.25pF(C)	ERB1885C2E2R0CDX1D	ERB21B5C2E2R0CDX1L
2.2pF(2R2)	±0.1pF(B)	ERB1885C2E2R2BDX1D	ERB21B5C2E2R2BDX1L
	±0.25pF(C)	ERB1885C2E2R2CDX1D	ERB21B5C2E2R2CDX1L
2.4pF(2R4)	±0.1pF(B)	ERB1885C2E2R4BDX1D	ERB21B5C2E2R4BDX1L
	±0.25pF(C)	ERB1885C2E2R4CDX1D	ERB21B5C2E2R4CDX1L
2.7pF(2R7)	±0.1pF(B)	ERB1885C2E2R7BDX1D	ERB21B5C2E2R7BDX1L
	±0.25pF(C)	ERB1885C2E2R7CDX1D	ERB21B5C2E2R7CDX1L
3.0pF(3R0)	±0.1pF(B)	ERB1885C2E3R0BDX1D	ERB21B5C2E3R0BDX1L
	±0.25pF(C)	ERB1885C2E3R0CDX1D	ERB21B5C2E3R0CDX1L
3.3pF(3R3)	±0.1pF(B)	ERB1885C2E3R3BDX1D	ERB21B5C2E3R3BDX1L
	±0.25pF(C)	ERB1885C2E3R3CDX1D	ERB21B5C2E3R3CDX1L
3.6pF(3R6)	±0.1pF(B)	ERB1885C2E3R6BDX1D	ERB21B5C2E3R6BDX1L
	±0.25pF(C)	ERB1885C2E3R6CDX1D	ERB21B5C2E3R6CDX1L
3.9pF(3R9)	±0.1pF(B)	ERB1885C2E3R9BDX1D	ERB21B5C2E3R9BDX1L
	±0.25pF(C)	ERB1885C2E3R9CDX1D	ERB21B5C2E3R9CDX1L
4.0pF(4R0)	±0.1pF(B)	ERB1885C2E4R0BDX1D	ERB21B5C2E4R0BDX1L
	±0.25pF(C)	ERB1885C2E4R0CDX1D	ERB21B5C2E4R0CDX1L
4.3pF(4R3)	±0.1pF(B)	ERB1885C2E4R3BDX1D	ERB21B5C2E4R3BDX1L
	±0.25pF(C)	ERB1885C2E4R3CDX1D	ERB21B5C2E4R3CDX1L
4.7pF(4R7)	±0.1pF(B)	ERB1885C2E4R7BDX1D	ERB21B5C2E4R7BDX1L
	±0.25pF(C)	ERB1885C2E4R7CDX1D	ERB21B5C2E4R7CDX1L
5.0pF(5R0)	±0.1pF(B)	ERB1885C2E5R0BDX1D	ERB21B5C2E5R0BDX1L
	±0.25pF(C)	ERB1885C2E5R0CDX1D	ERB21B5C2E5R0CDX1L
5.1pF(5R1)	±0.1pF(B)	ERB1885C2E5R1BDX1D	ERB21B5C2E5R1BDX1L
	±0.25pF(C)	ERB1885C2E5R1CDX1D	ERB21B5C2E5R1CDX1L
	±0.5pF(D)	ERB1885C2E5R1DDX1D	ERB21B5C2E5R1DDX1L
5.6pF(5R6)	±0.1pF(B)	ERB1885C2E5R6BDX1D	ERB21B5C2E5R6BDX1L
	±0.25pF(C)	ERB1885C2E5R6CDX1D	ERB21B5C2E5R6CDX1L
	±0.5pF(D)	ERB1885C2E5R6DDX1D	ERB21B5C2E5R6DDX1L
6.0pF(6R0)	±0.1pF(B)	ERB1885C2E6R0BDX1D	ERB21B5C2E6R0BDX1L
	±0.25pF(C)	ERB1885C2E6R0CDX1D	ERB21B5C2E6R0CDX1L
	±0.5pF(D)	ERB1885C2E6R0DDX1D	ERB21B5C2E6R0DDX1L

The part number code is shown in () and Unit is shown in []. < >: EIA [inch] Code

△Note • This PDF catalog is downloaded from the website of Murata Manufacturing co., Ltd. Therefore, it's specifications are subject to change or our products in it may be discontinued without advance notice. Please check with our sales representatives or product engineers before ordering.
• This PDF catalog has only typical specifications because there is no space for detailed specifications. Therefore, please approve our product specifications or transact the approval sheet for product specifications before ordering.

● Temperature Compensating Type C0G(5C) Characteristics

LxW [mm]		1.6x0.8(18)<0603>	2.0x1.25(21)<0805>
Rated Volt. [Vdc]		250(2E)	250(2E)
Capacitance	Tolerance	Part Number	
6.2pF(6R2)	±0.1pF(B)	ERB1885C2E6R2BDX1D	ERB21B5C2E6R2BDX1L
	±0.25pF(C)	ERB1885C2E6R2CDX1D	ERB21B5C2E6R2CDX1L
	±0.5pF(D)	ERB1885C2E6R2DDX1D	ERB21B5C2E6R2DDX1L
6.8pF(6R8)	±0.1pF(B)	ERB1885C2E6R8BDX1D	ERB21B5C2E6R8BDX1L
	±0.25pF(C)	ERB1885C2E6R8CDX1D	ERB21B5C2E6R8CDX1L
	±0.5pF(D)	ERB1885C2E6R8DDX1D	ERB21B5C2E6R8DDX1L
7.0pF(7R0)	±0.1pF(B)	ERB1885C2E7R0BDX5D	ERB21B5C2E7R0BDX1L
	±0.25pF(C)	ERB1885C2E7R0CDX5D	ERB21B5C2E7R0CDX1L
	±0.5pF(D)	ERB1885C2E7R0DDX5D	ERB21B5C2E7R0DDX1L
7.5pF(7R5)	±0.1pF(B)	ERB1885C2E7R5BDX5D	ERB21B5C2E7R5BDX1L
	±0.25pF(C)	ERB1885C2E7R5CDX5D	ERB21B5C2E7R5CDX1L
	±0.5pF(D)	ERB1885C2E7R5DDX5D	ERB21B5C2E7R5DDX1L
8.0pF(8R0)	±0.1pF(B)	ERB1885C2E8R0BDX5D	ERB21B5C2E8R0BDX1L
	±0.25pF(C)	ERB1885C2E8R0CDX5D	ERB21B5C2E8R0CDX1L
	±0.5pF(D)	ERB1885C2E8R0DDX5D	ERB21B5C2E8R0DDX1L
8.2pF(8R2)	±0.1pF(B)	ERB1885C2E8R2BDX5D	ERB21B5C2E8R2BDX1L
	±0.25pF(C)	ERB1885C2E8R2CDX5D	ERB21B5C2E8R2CDX1L
	±0.5pF(D)	ERB1885C2E8R2DDX5D	ERB21B5C2E8R2DDX1L
9.0pF(9R0)	±0.1pF(B)	ERB1885C2E9R0BDX5D	ERB21B5C2E9R0BDX1L
	±0.25pF(C)	ERB1885C2E9R0CDX5D	ERB21B5C2E9R0CDX1L
	±0.5pF(D)	ERB1885C2E9R0DDX5D	ERB21B5C2E9R0DDX1L
9.1pF(9R1)	±0.1pF(B)	ERB1885C2E9R1BDX5D	ERB21B5C2E9R1BDX1L
	±0.25pF(C)	ERB1885C2E9R1CDX5D	ERB21B5C2E9R1CDX1L
	±0.5pF(D)	ERB1885C2E9R1DDX5D	ERB21B5C2E9R1DDX1L
10pF(100)	±2%(G)	ERB1885C2E100GDX5D	ERB21B5C2E100GDX1L
	±5%(J)	ERB1885C2E100JDX5D	ERB21B5C2E100JDX1L
11pF(110)	±2%(G)	ERB1885C2E110GDX5D	ERB21B5C2E110GDX1L
	±5%(J)	ERB1885C2E110JDX5D	ERB21B5C2E110JDX1L
12pF(120)	±2%(G)	ERB1885C2E120GDX5D	ERB21B5C2E120GDX1L
	±5%(J)	ERB1885C2E120JDX5D	ERB21B5C2E120JDX1L
13pF(130)	±2%(G)	ERB1885C2E130GDX5D	ERB21B5C2E130GDX1L
	±5%(J)	ERB1885C2E130JDX5D	ERB21B5C2E130JDX1L
15pF(150)	±2%(G)	ERB1885C2E150GDX5D	ERB21B5C2E150GDX1L
	±5%(J)	ERB1885C2E150JDX5D	ERB21B5C2E150JDX1L
16pF(160)	±2%(G)	ERB1885C2E160GDX5D	ERB21B5C2E160GDX1L
	±5%(J)	ERB1885C2E160JDX5D	ERB21B5C2E160JDX1L
18pF(180)	±2%(G)	ERB1885C2E180GDX5D	ERB21B5C2E180GDX1L
	±5%(J)	ERB1885C2E180JDX5D	ERB21B5C2E180JDX1L
20pF(200)	±2%(G)	ERB1885C2E200GDX5D	ERB21B5C2E200GDX1L
	±5%(J)	ERB1885C2E200JDX5D	ERB21B5C2E200JDX1L
22pF(220)	±2%(G)	ERB1885C2E220GDX5D	ERB21B5C2E220GDX1L
	±5%(J)	ERB1885C2E220JDX5D	ERB21B5C2E220JDX1L
24pF(240)	±2%(G)	ERB1885C2E240GDX5D	ERB21B5C2E240GDX1L
	±5%(J)	ERB1885C2E240JDX5D	ERB21B5C2E240JDX1L
27pF(270)	±2%(G)	ERB1885C2E270GDX5D	ERB21B5C2E270GDX1L
	±5%(J)	ERB1885C2E270JDX5D	ERB21B5C2E270JDX1L
30pF(300)	±2%(G)	ERB1885C2E300GDX5D	ERB21B5C2E300GDX1L
	±5%(J)	ERB1885C2E300JDX5D	ERB21B5C2E300JDX1L
33pF(330)	±2%(G)	ERB1885C2E330GDX5D	ERB21B5C2E330GDX1L
	±5%(J)	ERB1885C2E330JDX5D	ERB21B5C2E330JDX1L

The part number code is shown in () and Unit is shown in []. < >: EIA [inch] Code

● Temperature Compensating Type C0G(5C) Characteristics

LxW [mm]		1.6x0.8(18)<0603>		2.0x1.25(21)<0805>	
Rated Volt. [Vdc]		250(2E)		250(2E)	100(2A)
Capacitance	Tolerance	Part Number			
36pF(360)	±2%(G)	ERB1885C2E360GDX5D	ERB21B5C2E360GDX1L		
	±5%(J)	ERB1885C2E360JDX5D	ERB21B5C2E360JDX1L		
39pF(390)	±2%(G)	ERB1885C2E390GDX5D	ERB21B5C2E390GDX1L		
	±5%(J)	ERB1885C2E390JDX5D	ERB21B5C2E390JDX1L		
43pF(430)	±2%(G)	ERB1885C2E430GDX5D	ERB21B5C2E430GDX1L		
	±5%(J)	ERB1885C2E430JDX5D	ERB21B5C2E430JDX1L		
47pF(470)	±2%(G)	ERB1885C2E470GDX5D	ERB21B5C2E470GDX1L		
	±5%(J)	ERB1885C2E470JDX5D	ERB21B5C2E470JDX1L		
51pF(510)	±2%(G)	ERB1885C2E510GDX5D	ERB21B5C2E510GDX1L		
	±5%(J)	ERB1885C2E510JDX5D	ERB21B5C2E510JDX1L		
56pF(560)	±2%(G)	ERB1885C2E560GDX5D	ERB21B5C2E560GDX1L		
	±5%(J)	ERB1885C2E560JDX5D	ERB21B5C2E560JDX1L		
62pF(620)	±2%(G)	ERB1885C2E620GDX5D	ERB21B5C2E620GDX1L		
	±5%(J)	ERB1885C2E620JDX5D	ERB21B5C2E620JDX1L		
68pF(680)	±2%(G)	ERB1885C2E680GDX5D	ERB21B5C2E680GDX1L		
	±5%(J)	ERB1885C2E680JDX5D	ERB21B5C2E680JDX1L		
75pF(750)	±2%(G)	ERB1885C2E750GDX5D	ERB21B5C2E750GDX1L		
	±5%(J)	ERB1885C2E750JDX5D	ERB21B5C2E750JDX1L		
82pF(820)	±2%(G)	ERB1885C2E820GDX5D	ERB21B5C2E820GDX1L		
	±5%(J)	ERB1885C2E820JDX5D	ERB21B5C2E820JDX1L		
91pF(910)	±2%(G)	ERB1885C2E910GDX5D	ERB21B5C2E910GDX1L		
	±5%(J)	ERB1885C2E910JDX5D	ERB21B5C2E910JDX1L		
100pF(101)	±2%(G)	ERB1885C2E101GDX5D	ERB21B5C2E101GDX1L		
	±5%(J)	ERB1885C2E101JDX5D	ERB21B5C2E101JDX1L		
110pF(111)	±2%(G)			ERB21B5C2A111GDX1L	
	±5%(J)			ERB21B5C2A111JDX1L	
120pF(121)	±2%(G)			ERB21B5C2A121GDX1L	
	±5%(J)			ERB21B5C2A121JDX1L	
130pF(131)	±2%(G)			ERB21B5C2A131GDX1L	
	±5%(J)			ERB21B5C2A131JDX1L	
150pF(151)	±2%(G)				ERB21B5C1H151GDX1L
	±5%(J)				ERB21B5C1H151JDX1L
160pF(161)	±2%(G)				ERB21B5C1H161GDX1L
	±5%(J)				ERB21B5C1H161JDX1L

The part number code is shown in () and Unit is shown in []. < >: EIA [inch] Code

△Note • This PDF catalog is downloaded from the website of Murata Manufacturing co., ltd. Therefore, it's specifications are subject to change or our products in it may be discontinued without advance notice. Please check with our sales representatives or product engineers before ordering.
• This PDF catalog has only typical specifications because there is no space for detailed specifications. Therefore, please approve our product specifications or transact the approval sheet for product specifications before ordering.

● Temperature Compensating Type C0G(5C) Characteristics

LxW [mm]		3.2x2.5(32)<1210>	
Rated Volt. [Vdc]		500(2H)	
Capacitance	Tolerance	Part Number	
3.3pF(3R3)	±0.1pF(B)	ERB32Q5C2H3R3BDX1L	
	±0.25pF(C)	ERB32Q5C2H3R3CDX1L	
3.6pF(3R6)	±0.1pF(B)	ERB32Q5C2H3R6BDX1L	
	±0.25pF(C)	ERB32Q5C2H3R6CDX1L	
3.9pF(3R9)	±0.1pF(B)	ERB32Q5C2H3R9BDX1L	
	±0.25pF(C)	ERB32Q5C2H3R9CDX1L	
4.0pF(4R0)	±0.1pF(B)	ERB32Q5C2H4R0BDX1L	
	±0.25pF(C)	ERB32Q5C2H4R0CDX1L	
4.3pF(4R3)	±0.1pF(B)	ERB32Q5C2H4R3BDX1L	
	±0.25pF(C)	ERB32Q5C2H4R3CDX1L	
4.7pF(4R7)	±0.1pF(B)	ERB32Q5C2H4R7BDX1L	
	±0.25pF(C)	ERB32Q5C2H4R7CDX1L	
5.0pF(5R0)	±0.1pF(B)	ERB32Q5C2H5R0BDX1L	
	±0.25pF(C)	ERB32Q5C2H5R0CDX1L	
5.1pF(5R1)	±0.1pF(B)	ERB32Q5C2H5R1BDX1L	
	±0.25pF(C)	ERB32Q5C2H5R1CDX1L	
	±0.5pF(D)	ERB32Q5C2H5R1DDX1L	
5.6pF(5R6)	±0.1pF(B)	ERB32Q5C2H5R6BDX1L	
	±0.25pF(C)	ERB32Q5C2H5R6CDX1L	
	±0.5pF(D)	ERB32Q5C2H5R6DDX1L	
6.0pF(6R0)	±0.1pF(B)	ERB32Q5C2H6R0BDX1L	
	±0.25pF(C)	ERB32Q5C2H6R0CDX1L	
	±0.5pF(D)	ERB32Q5C2H6R0DDX1L	
6.2pF(6R2)	±0.1pF(B)	ERB32Q5C2H6R2BDX1L	
	±0.25pF(C)	ERB32Q5C2H6R2CDX1L	
	±0.5pF(D)	ERB32Q5C2H6R2DDX1L	
6.8pF(6R8)	±0.1pF(B)	ERB32Q5C2H6R8BDX1L	
	±0.25pF(C)	ERB32Q5C2H6R8CDX1L	
	±0.5pF(D)	ERB32Q5C2H6R8DDX1L	
7.0pF(7R0)	±0.1pF(B)	ERB32Q5C2H7R0BDX1L	
	±0.25pF(C)	ERB32Q5C2H7R0CDX1L	
	±0.5pF(D)	ERB32Q5C2H7R0DDX1L	
7.5pF(7R5)	±0.1pF(B)	ERB32Q5C2H7R5BDX1L	
	±0.25pF(C)	ERB32Q5C2H7R5CDX1L	
	±0.5pF(D)	ERB32Q5C2H7R5DDX1L	
8.0pF(8R0)	±0.1pF(B)	ERB32Q5C2H8R0BDX1L	
	±0.25pF(C)	ERB32Q5C2H8R0CDX1L	
	±0.5pF(D)	ERB32Q5C2H8R0DDX1L	
8.2pF(8R2)	±0.1pF(B)	ERB32Q5C2H8R2BDX1L	
	±0.25pF(C)	ERB32Q5C2H8R2CDX1L	
	±0.5pF(D)	ERB32Q5C2H8R2DDX1L	
9.0pF(9R0)	±0.1pF(B)	ERB32Q5C2H9R0BDX1L	
	±0.25pF(C)	ERB32Q5C2H9R0CDX1L	
	±0.5pF(D)	ERB32Q5C2H9R0DDX1L	
9.1pF(9R1)	±0.1pF(B)	ERB32Q5C2H9R1BDX1L	
	±0.25pF(C)	ERB32Q5C2H9R1CDX1L	
	±0.5pF(D)	ERB32Q5C2H9R1DDX1L	
10pF(100)	±2%(G)	ERB32Q5C2H100GDX1L	
	±5%(J)	ERB32Q5C2H100JDX1L	

LxW [mm]		3.2x2.5(32)<1210>	
Rated Volt. [Vdc]		500(2H)	
Capacitance	Tolerance	Part Number	
11pF(110)	±2%(G)	ERB32Q5C2H110GDX1L	
	±5%(J)	ERB32Q5C2H110JDX1L	
12pF(120)	±2%(G)	ERB32Q5C2H120GDX1L	
	±5%(J)	ERB32Q5C2H120JDX1L	
13pF(130)	±2%(G)	ERB32Q5C2H130GDX1L	
	±5%(J)	ERB32Q5C2H130JDX1L	
15pF(150)	±2%(G)	ERB32Q5C2H150GDX1L	
	±5%(J)	ERB32Q5C2H150JDX1L	
16pF(160)	±2%(G)	ERB32Q5C2H160GDX1L	
	±5%(J)	ERB32Q5C2H160JDX1L	
18pF(180)	±2%(G)	ERB32Q5C2H180GDX1L	
	±5%(J)	ERB32Q5C2H180JDX1L	
20pF(200)	±2%(G)	ERB32Q5C2H200GDX1L	
	±5%(J)	ERB32Q5C2H200JDX1L	
22pF(220)	±2%(G)	ERB32Q5C2H220GDX1L	
	±5%(J)	ERB32Q5C2H220JDX1L	
24pF(240)	±2%(G)	ERB32Q5C2H240GDX1L	
	±5%(J)	ERB32Q5C2H240JDX1L	
27pF(270)	±2%(G)	ERB32Q5C2H270GDX1L	
	±5%(J)	ERB32Q5C2H270JDX1L	
30pF(300)	±2%(G)	ERB32Q5C2H300GDX1L	
	±5%(J)	ERB32Q5C2H300JDX1L	
33pF(330)	±2%(G)	ERB32Q5C2H330GDX1L	
	±5%(J)	ERB32Q5C2H330JDX1L	
36pF(360)	±2%(G)	ERB32Q5C2H360GDX1L	
	±5%(J)	ERB32Q5C2H360JDX1L	
39pF(390)	±2%(G)	ERB32Q5C2H390GDX1L	
	±5%(J)	ERB32Q5C2H390JDX1L	
43pF(430)	±2%(G)	ERB32Q5C2H430GDX1L	
	±5%(J)	ERB32Q5C2H430JDX1L	
47pF(470)	±2%(G)	ERB32Q5C2H470GDX1L	
	±5%(J)	ERB32Q5C2H470JDX1L	
51pF(510)	±2%(G)	ERB32Q5C2H510GDX1L	
	±5%(J)	ERB32Q5C2H510JDX1L	
56pF(560)	±2%(G)	ERB32Q5C2H560GDX1L	
	±5%(J)	ERB32Q5C2H560JDX1L	
62pF(620)	±2%(G)	ERB32Q5C2H620GDX1L	
	±5%(J)	ERB32Q5C2H620JDX1L	
68pF(680)	±2%(G)	ERB32Q5C2H680GDX1L	
	±5%(J)	ERB32Q5C2H680JDX1L	
75pF(750)	±2%(G)	ERB32Q5C2H750GDX1L	
	±5%(J)	ERB32Q5C2H750JDX1L	
82pF(820)	±2%(G)	ERB32Q5C2H820GDX1L	
	±5%(J)	ERB32Q5C2H820JDX1L	
91pF(910)	±2%(G)	ERB32Q5C2H910GDX1L	
	±5%(J)	ERB32Q5C2H910JDX1L	
100pF(101)	±2%(G)	ERB32Q5C2H101GDX1L	
	±5%(J)	ERB32Q5C2H101JDX1L	

The part number code is shown in () and Unit is shown in []. < >: EIA [inch] Code

● Temperature Compensating Type C0G(5C) Characteristics

LxW [mm]		3.2x2.5(32)<1210>			
Rated Volt. [Vdc]		500(2H)	300(YD)	250(2E)	100(2A)
Capacitance	Tolerance	Part Number			
110pF(111)	±2%(G)	ERB32Q5C2H111GDX1L			
	±5%(J)	ERB32Q5C2H111JDX1L			
120pF(121)	±2%(G)	ERB32Q5C2H121GDX1L			
	±5%(J)	ERB32Q5C2H121JDX1L			
130pF(131)	±2%(G)		ERB32Q5CYD131GDX1L		
	±5%(J)		ERB32Q5CYD131JDX1L		
150pF(151)	±2%(G)		ERB32Q5CYD151GDX1L		
	±5%(J)		ERB32Q5CYD151JDX1L		
160pF(161)	±2%(G)			ERB32Q5C2E161GDX1L	
	±5%(J)			ERB32Q5C2E161JDX1L	
180pF(181)	±2%(G)			ERB32Q5C2E181GDX1L	
	±5%(J)			ERB32Q5C2E181JDX1L	
200pF(201)	±2%(G)			ERB32Q5C2E201GDX1L	
	±5%(J)			ERB32Q5C2E201JDX1L	
220pF(221)	±2%(G)			ERB32Q5C2E221GDX1L	
	±5%(J)			ERB32Q5C2E221JDX1L	
240pF(241)	±2%(G)				ERB32Q5C2A241GDX1L
	±5%(J)				ERB32Q5C2A241JDX1L
270pF(271)	±2%(G)				ERB32Q5C2A271GDX1L
	±5%(J)				ERB32Q5C2A271JDX1L
300pF(301)	±2%(G)				ERB32Q5C2A301GDX1L
	±5%(J)				ERB32Q5C2A301JDX1L
330pF(331)	±2%(G)				ERB32Q5C2A331GDX1L
	±5%(J)				ERB32Q5C2A331JDX1L
360pF(361)	±2%(G)				ERB32Q5C2A361GDX1L
	±5%(J)				ERB32Q5C2A361JDX1L
390pF(391)	±2%(G)				ERB32Q5C2A391GDX1L
	±5%(J)				ERB32Q5C2A391JDX1L
430pF(431)	±2%(G)				ERB32Q5C2A431GDX1L
	±5%(J)				ERB32Q5C2A431JDX1L
470pF(471)	±2%(G)				ERB32Q5C2A471GDX1L
	±5%(J)				ERB32Q5C2A471JDX1L

LxW [mm]		3.2x2.5(32)<1210>
Rated Volt. [Vdc]		50(1H)
Capacitance	Tolerance	Part Number
510pF(511)	±2%(G)	ERB32Q5C1H511GDX1L
	±5%(J)	ERB32Q5C1H511JDX1L
560pF(561)	±2%(G)	ERB32Q5C1H561GDX1L
	±5%(J)	ERB32Q5C1H561JDX1L
620pF(621)	±2%(G)	ERB32Q5C1H621GDX1L
	±5%(J)	ERB32Q5C1H621JDX1L
680pF(681)	±2%(G)	ERB32Q5C1H681GDX1L
	±5%(J)	ERB32Q5C1H681JDX1L
750pF(751)	±2%(G)	ERB32Q5C1H751GDX1L
	±5%(J)	ERB32Q5C1H751JDX1L
820pF(821)	±2%(G)	ERB32Q5C1H821GDX1L
	±5%(J)	ERB32Q5C1H821JDX1L
910pF(911)	±2%(G)	ERB32Q5C1H911GDX1L
	±5%(J)	ERB32Q5C1H911JDX1L
1000pF(102)	±2%(G)	ERB32Q5C1H102GDX1L
	±5%(J)	ERB32Q5C1H102JDX1L

The part number code is shown in () and Unit is shown in []. < >: EIA [inch] Code

△Note • This PDF catalog is downloaded from the website of Murata Manufacturing co., Ltd. Therefore, it's specifications are subject to change or our products in it may be discontinued without advance notice. Please check with our sales representatives or product engineers before ordering.
• This PDF catalog has only typical specifications because there is no space for detailed specifications. Therefore, please approve our product specifications or transact the approval sheet for product specifications before ordering.

High Frequency Single Layer Microchip Capacitors

● Temperature Compensating Type

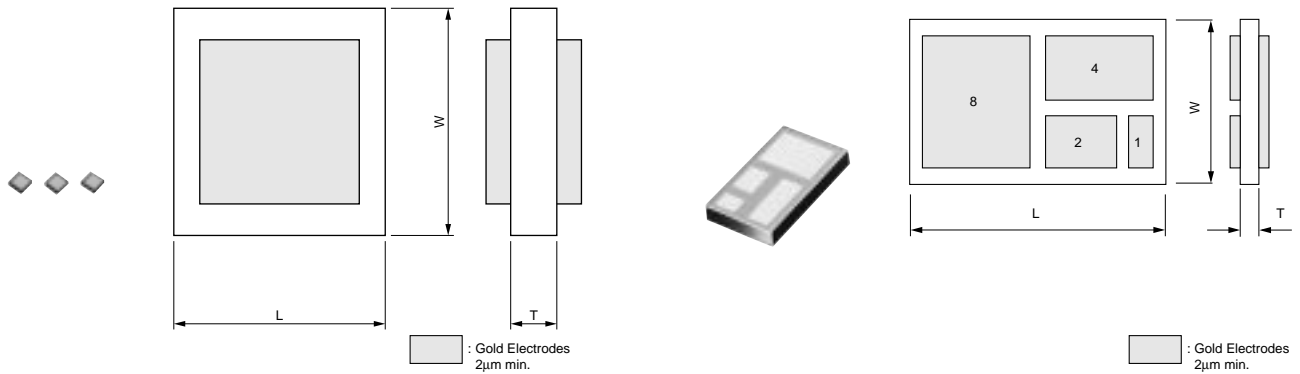

Part Number	Capacitance at 25°C (pF)	Temperature Coefficient	Rated Voltage (Vdc)
CLB0A	0.1	0±30ppm/°C	100
CLB0C	0.2	0±30ppm/°C	100
CLB0D	0.2 to 0.4	0±30ppm/°C	100
CLB05	0.3 to 0.6	0±30ppm/°C	100
CLB0E	0.5 to 0.6	0±30ppm/°C	100
CLB0F	0.3 to 1.0	0±30ppm/°C	100
CLB0G	0.7 to 1.0	0±30ppm/°C	100
CLB0H	0.7 to 0.8	0±30ppm/°C	100
CLB0J	0.4 to 1.3	0±30ppm/°C	100
CLB09	0.5 to 1.8	0±30ppm/°C	100
CLB1A	1.1 to 1.6	0±30ppm/°C	100
CLB1B	1.5 to 2.0	0±30ppm/°C	100
CLB1C	1.0 to 3.6	0±30ppm/°C	100
CLB1E	2.0 to 2.7	0±30ppm/°C	100
CLB1G	3.9 to 4.7	0±30ppm/°C	100
CLB1H	1.8 to 6.8	0±30ppm/°C	100
CLB2C	5.1	0±30ppm/°C	100
CLB2E	3.0 to 10	0±30ppm/°C	100
CLB2L	7.5 to 10	0±30ppm/°C	100
CLB3G	11 to 16	0±30ppm/°C	100
CLB0A	0.3 to 0.7	-750±60ppm/°C	100
CLB0B	0.8	-750±60ppm/°C	100
CLB0C	0.9	-750±60ppm/°C	100
CLB0D	0.9 to 1.6	-750±60ppm/°C	100
CLB05	0.7	-750±60ppm/°C	100
CLB05	1.0 to 2.4	-750±60ppm/°C	100
CLB0E	1.8 to 2.4	-750±60ppm/°C	100
CLB0F	2.0 to 4.3	-750±60ppm/°C	100
CLB0G	2.7 to 3.0	-750±60ppm/°C	100
CLB0H	2.7	-750±60ppm/°C	100
CLB0J	3.0 to 6.2	-750±60ppm/°C	100
CLB0K	1.5	-750±60ppm/°C	100
CLB09	3.3 to 6.8	-750±60ppm/°C	100
CLB1A	4.7 to 6.2	-750±60ppm/°C	100
CLB1B	6.8 to 7.5	-750±60ppm/°C	100
CLB1C	7.5 to 15	-750±60ppm/°C	100
CLB1E	7.5 to 9.1	-750±60ppm/°C	100
CLB1H	13 to 15	-750±60ppm/°C	100
CLB2E	20	-750±60ppm/°C	100

Continued on the following page.

⚠Note • This PDF catalog is downloaded from the website of Murata Manufacturing co., Ltd. Therefore, it's specifications are subject to change or our products in it may be discontinued without advance notice. Please check with our sales representatives or product engineers before ordering.
• This PDF catalog has only typical specifications because there is no space for detailed specifications. Therefore, please approve our product specifications or transact the approval sheet for product specifications before ordering.

Continued from the preceding page.

Part Number	Capacitance at 25°C (pF)	Temperature Coefficient	Rated Voltage (Vdc)
CLB0A	0.8 to 1.3	-2200±500ppm/°C	100
CLB0B	1.5 to 1.6	-2200±500ppm/°C	100
CLB0C	1.8	-2200±500ppm/°C	100
CLB0D	1.8 to 3.0	-2200±500ppm/°C	100
CLB05	1.5	-2200±500ppm/°C	100
CLB05	2.2 to 4.7	-2200±500ppm/°C	100
CLB0E	3.3 to 4.3	-2200±500ppm/°C	100
CLB0F	3.6 to 7.5	-2200±500ppm/°C	100
CLB0G	5.1 to 5.6	-2200±500ppm/°C	100
CLB0H	4.7 to 5.1	-2200±500ppm/°C	100
CLB0J	5.6 to 11	-2200±500ppm/°C	100
CLB0K	3.0	-2200±500ppm/°C	100
CLB09	6.2 to 13	-2200±500ppm/°C	100
CLB1A	8.2 to 11	-2200±500ppm/°C	100
CLB1B	12	-2200±500ppm/°C	100
CLB1C	15 to 22	-2200±500ppm/°C	100
CLB1E	15 to 16	-2200±500ppm/°C	100
CLB1G	33	-2200±500ppm/°C	100
CLB1H	27	-2200±500ppm/°C	100
CLB2E	39 to 47	-2200±500ppm/°C	100

Capacitance value steps are in accordance with EIA E24 steps. However, capacitance values below 1pF are treated as belonging to 0.1pF step. Please refer to LxW size in "Global Part Numbering" guidance page.

● High Dielectric Constant Type

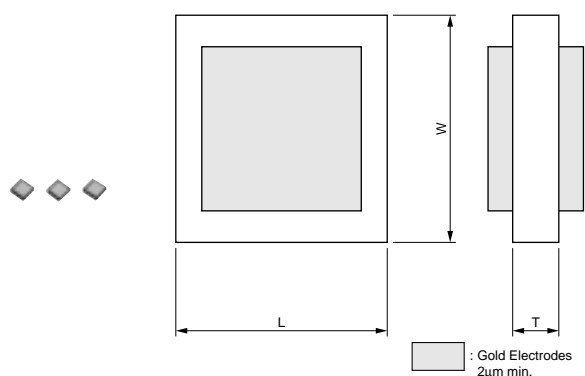

Part Number	Capacitance at 25°C (pF)	Temperature Coefficient	Rated Voltage (Vdc)
CLB0A	2.0 to 3.0	±10%	100
CLB0A	4.7 to 12	±10%	100
CLB0B	3.3 to 3.6	±10%	100
CLB0B	13 to 15	±10%	100
CLB0C	3.9 to 4.3	±10%	100
CLB0C	16 to 18	±10%	100
CLB0D	5.1 to 7.5	±10%	100
CLB0D	11 to 30	±10%	100
CLB05	5.6 to 43	±10%	100
CLB0E	8.2 to 10	±10%	100
CLB0E	33 to 43	±10%	100
CLB0F	10 to 75	±10%	100
CLB0G	47 to 68	±10%	100
CLB0H	47 to 56	±10%	100
CLB0J	15 to 110	±10%	100

Continued on the following page.

Note • This PDF catalog is downloaded from the website of Murata Manufacturing co., ltd. Therefore, it's specifications are subject to change or our products in it may be discontinued without advance notice. Please check with our sales representatives or product engineers before ordering.
• This PDF catalog has only typical specifications because there is no space for detailed specifications. Therefore, please approve our product specifications or transact the approval sheet for product specifications before ordering.

Continued from the preceding page.

Part Number	Capacitance at 25°C (pF)	Temperature Coefficient	Rated Voltage (Vdc)
CLB09	16 to 130	±10%	100
CLB1A	82 to 120	±10%	100
CLB1C	33 to 62	±10%	100
CLB1C	75 to 200	±10%	100
CLB1E	150 to 160	±10%	100
CLB1G	300	±10%	100
CLB1H	130 to 430	±10%	100
CLB2E	200 to 620	±10%	100
CLB0A	27 to 33	+30/-80%	100
CLB0B	36 to 39	+30/-80%	100
CLB0C	43 to 51	+30/-80%	100
CLB0D	62 to 82	+30/-80%	100
CLB05	75 to 130	+30/-80%	100
CLB0E	91 to 120	+30/-80%	100
CLB0F	130 to 220	+30/-80%	100
CLB0G	150 to 200	+30/-80%	100
CLB0H	130 to 150	+30/-80%	100
CLB0J	200 to 300	+30/-80%	100
CLB09	200 to 390	+30/-80%	100
CLB1A	240 to 360	+30/-80%	100
CLB0A	36 to 56	+30/-90%	100
CLB0D	91 to 150	+30/-90%	100
CLB05	130 to 220	+30/-90%	100
CLB0F	220 to 390	+30/-90%	100
CLB0J	330 to 560	+30/-90%	100
CLB09	390 to 680	+30/-90%	100

Capacitance value steps are in accordance with EIA E24 steps.
 Some of capacitances are not available in the range of CLB0A/B/C/D/E series.
 Please refer to LxW size in "Global Part Numbering" guidance page.

Thin Film Circuit Substrate (RUSUB®)

for Photo Diode Module

● Features

- RUSUB® technology provides single-layer capacitor and thin film resistor formed in one chip. It reduces not only numbers of parts to build a device, but also the assembly costs. It will also contribute to make a device smaller.
- The single-layer structure makes its self-resonant frequency higher. It allows the devices to operate stable even at a high frequency range.
- Short distance between the capacitor and thin film resistor makes the residue inductance smaller and it contributes to attenuate unnecessary noise. So the device can work at its best characteristics.
- Since it has gold electrode, it is feasible to be installed inside a module, and it allows wire-bonding with gold wire.
- AuSn pre-coating finish is also available.
- It is very suitable for APD (Avalanche Photo Diode), because the capacitor has withstanding voltage of 100V.

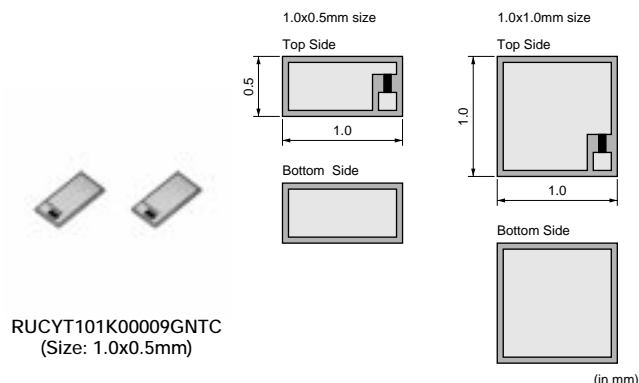

● Main Application

- Low pass filter for power supply of PD (Photo Diode).
- Low pass filter for power supply of TIA (Transimpedance Amp. = Pre Amp.).

● Specification

Parameter	Value
Temperature Characteristics of Capacitance (TC) @-25°C to +85°C	±10%
Capacitor Rated Voltage	100V
Temperature Coefficient of Resistance (TCR)	-70 ±50ppm/°C
Resistor Rated Power	100mW/mm ²
Dielectric Constant (εr)	3000 (typ.)
Structure of Metalized Film	Top Side: TaN/Ti/Pd/Au (Min 4um) Bottom Side: Ti/Pd/Au (Min 4um)

● Product Example

- Six types of standard samples of RUSUB® C+R (Capacitor + Resistor) for evaluation are available.
- The individual substrate size, capacity, resistance value, and electrode pattern shape is available upon request.

Part Number	Size	Thickness	Capacitance	Resistance
RUCYT101K0009GNTC	1.0mm x 0.5mm	0.11 ±0.025mm	100pF ±10%	50Ω ±20%
RUCYT101K00011GNTC	1.0mm x 0.5mm	0.11 ±0.025mm	100pF ±10%	100Ω ±20%
RUCYT101K00012GNTC	1.0mm x 0.5mm	0.11 ±0.025mm	100pF ±10%	200Ω ±20%
RUCYT201K00010GNTC	1.0mm x 1.0mm	0.12 ±0.025mm	200pF ±10%	50Ω ±20%
RUCYT201K00013GNTC	1.0mm x 1.0mm	0.12 ±0.025mm	200pF ±10%	100Ω ±20%
RUCYT201K00014GNTC	1.0mm x 1.0mm	0.12 ±0.025mm	200pF ±10%	200Ω ±20%

● Frequency Characteristics

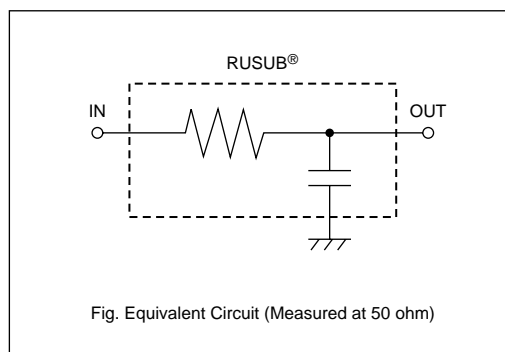
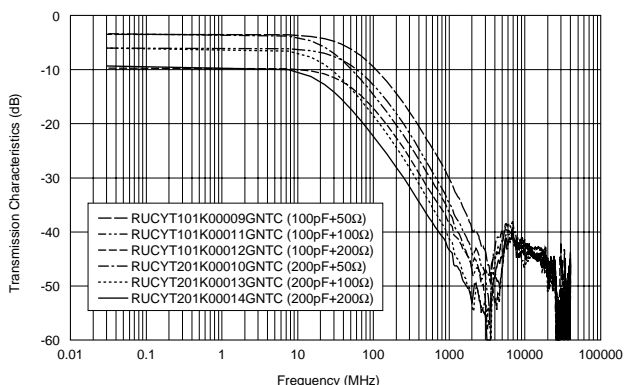

△Note • This PDF catalog is downloaded from the website of Murata Manufacturing co., ltd. Therefore, it's specifications are subject to change or our products in it may be discontinued without advance notice. Please check with our sales representatives or product engineers before ordering.
• This PDF catalog has only typical specifications because there is no space for detailed specifications. Therefore, please approve our product specifications or transact the approval sheet for product specifications before ordering.

Coaxial Connectors



MM4829-2702

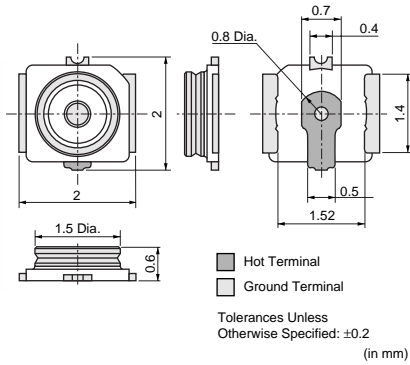

Dimensions

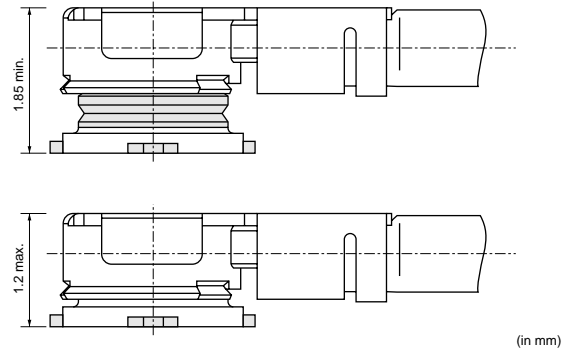

MM9329-2700

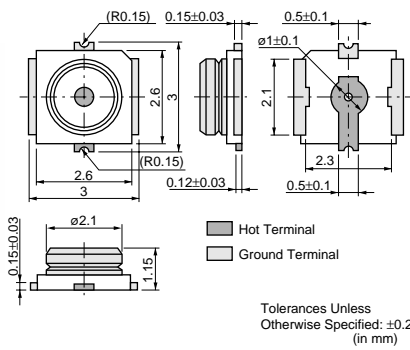

Dimensions

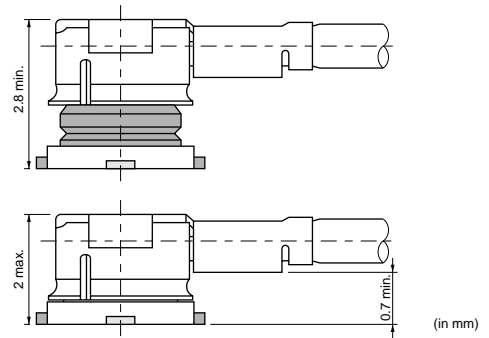

Part Number	Rated Voltage (V)	Frequency Rating (GHz)	Temperature Range	VSWR
MM4829-2702	250	to 6.0	-40 to +85degree C	1.3 max. (DC to 3GHz)
MM9329-2700	250	to 6.0	-40 to +90degree C	1.2 max. (DC to 3GHz)
MXHP32_TYPE	250	to 6.0	-40 to +85degree C	1.3 max.(DC to 3GHz)
MXTK92_TYPE	250	to 6.0	-40 to +90degree C	1.2 max.(DC to 3GHz)

Impedance: 50ohm

Microwave Components

8

Coaxial Connectors with Switches



MM8130-2600

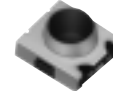
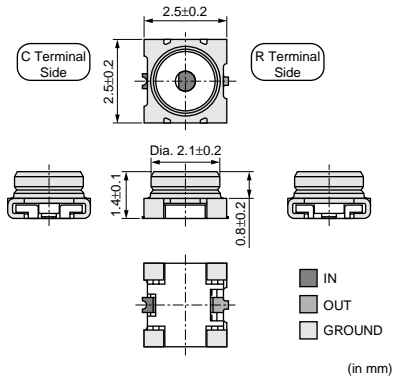

MM8430-2610

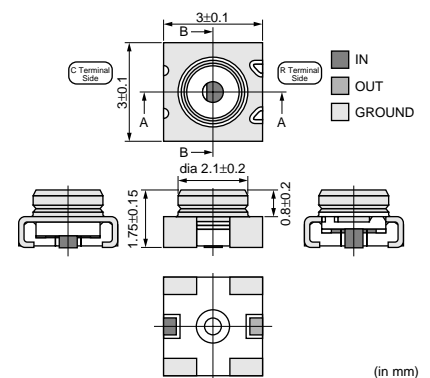

Continued on the following page.

Note • This PDF catalog is downloaded from the website of Murata Manufacturing co., ltd. Therefore, it's specifications are subject to change or our products in it may be discontinued without advance notice. Please check with our sales representatives or product engineers before ordering.
• This PDF catalog has only typical specifications because there is no space for detailed specifications. Therefore, please approve our product specifications or transact the approval sheet for product specifications before ordering.

Continued from the preceding page.

Measurement Probe (P/N:MM126036)

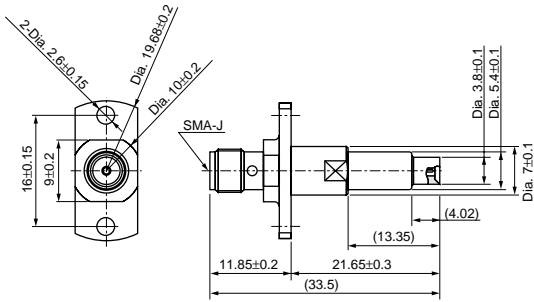

(in mm)

Measurement Probe (P/N:MXHS83QE3000)

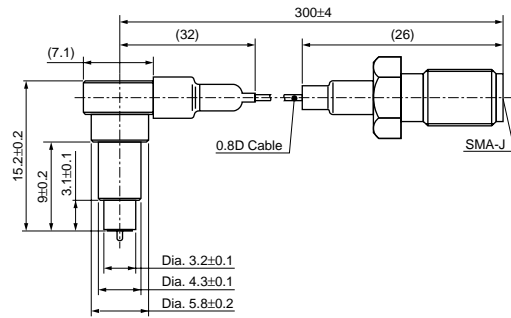

(in mm)

Measurement Probe (P/N:MXHS83QH3000)

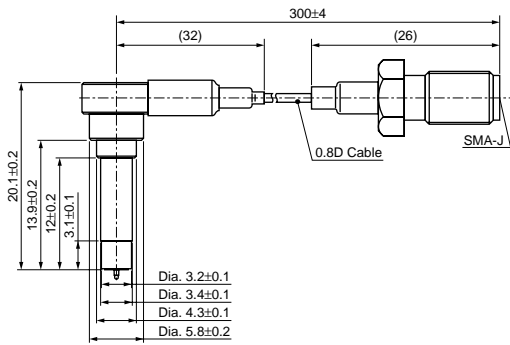

(in mm)

Part Number	Rated Voltage (Vrms)	Frequency Rating (GHz)	Temperature Range	VSWR
MM8130-2600	250	to 6	-40 to +85degree C	1.2 max. (DC to 3GHz)
MM8430-2610	250	to 6	-40 to +85degree C	1.2 max.(DC to 3GHz)

Impedance: 50ohm

Note • This PDF catalog is downloaded from the website of Murata Manufacturing co., ltd. Therefore, it's specifications are subject to change or our products in it may be discontinued without advance notice. Please check with our sales representatives or product engineers before ordering.
• This PDF catalog has only typical specifications because there is no space for detailed specifications. Therefore, please approve our product specifications or transact the approval sheet for product specifications before ordering.

9

Sensors

PTC Thermistors (for Overheat Sensing)

Pyroelectric Infrared Sensors

Fresnel Lens

Ultrasonic Sensors

Shock Sensors

Gyro Sensors

Rotary Position Sensors

Rotary Sensors

Magnetic Pattern Recognition Sensors

Magnetic Switch

● **Part Numbering**

PTC Thermistors (POSISTOR®) for Overheat Sensing Chip Type

(Part Number) **PR** **F** **18** **BB** **471** **Q** **B5** **RB**
 ① ② ③ ④ ⑤ ⑥ ⑦ ⑧

- ① Product ID
- ② Series
- ③ Dimensions (L×W)
- ④ Temperature Characteristics

Code	Temperature Characteristics
AR	Curie Point 120°C
AS	Curie Point 130°C
BA	Curie Point 110°C
BB	Curie Point 100°C
BC	Curie Point 90°C
BD	Curie Point 80°C
BE	Curie Point 70°C
BF	Curie Point 60°C
BG	Curie Point 50°C

⑤ Resistance

Expressed by three figures. The unit is ohm (Ω). The first and second figures are significant digits, and the third figure expresses the number of zeros which follow the two figures.

Ex.)

Code	Resistance
471	470Ω

- ⑥ Resistance Tolerance
- ⑦ Individual Specifications
- ⑧ Packaging

Code	Packaging
RA	Embossed Taping 4mm Pitch (4000 pcs.)
RB	Paper Taping 4mm Pitch (4000 pcs.)
RC	Paper Taping 2mm Pitch (10000 pcs.)

PTC Thermistors (POSISTOR®) for Overheat Sensing Lead Type

(Part Number) **PT** **FL** **04** **BB** **222** **Q** **2N34** **B0**
 ① ② ③ ④ ⑤ ⑥ ⑦ ⑧

- ① Product ID
- ② Series
- ③ Dimensions
- ④ Temperature Characteristics

Code	Temperature Characteristics
BB	Curie Point 100°C
BC	Curie Point 90°C
BD	Curie Point 80°C
BE	Curie Point 70°C
BF	Curie Point 60°C
BG	Curie Point 50°C
BH	Curie Point 40°C

⑤ Resistance

Expressed by three-digit alphanumerics. The unit is ohm (Ω). The first and second figures are significant digits, and the third figure expresses the number of zeros which follow the two figures.

Ex.)

Code	Resistance
222	2.2kΩ
471	470Ω

- ⑥ Resistance Tolerance
- ⑦ Individual Specifications
- ⑧ Packaging

Code	Packaging
B0	Bulk

Pyroelectric Infrared Sensors

(Part Number) **IR** **S-** **A200ST** **01** **-R1**
 ① ② ③ ④ ⑤

- ① Product ID
- ② Type
- ③ Characteristics
- ④ Individual Specification Code
- ⑤ Packaging

* "(Part Number)" shows only an example which might be different from actual part number.

* "③ Characteristics" and "④ Individual Specification Code" might have different digit number from actual part number.

Fresnel Lens

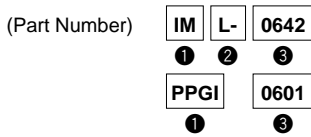

- ① Product ID
- ② Type
- ③ Characteristics

* "(Part Number)" shows only an example which might be different from actual part number.
 * "③ Characteristics" might have a different digit number from actual part number.

Ultrasonic Sensors

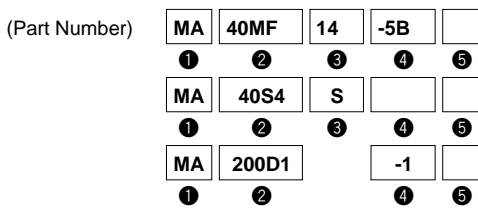

- ① Product ID
- ② Series
- ③ Characteristics
- ④ Individual Specification Code
- ⑤ Packaging

* "(Part Number)" shows only an example which might be different from actual part number.
 * Any other definitions than "① Product ID" might have different digit numbers from actual part number.

Shock Sensors (SMD Type)



- ① Product ID
- ② Series
- ③ Characteristics
- ④ Individual Specification Code
- ⑤ Packaging

* "(Part Number)" shows only an example which might be different from actual part number.
 * "③ Characteristics", "④ Individual Specification Code" and "⑤ Packaging" might have different digit number from actual part number.

Gyro Sensors

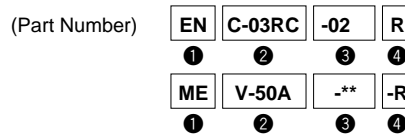

- ① Product ID
- ② Type
- ③ Individual Specification Code
- ④ Packaging

* "(Part Number)" shows only an example which might be different from actual part number.
 * Any other definitions than "① Product ID" might have a different digit number from actual part number.

Rotary Position Sensor

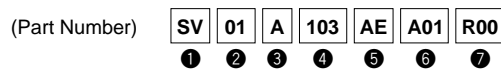

- ① Product ID
- ② Series
- ③ Terminal Shape

Code	Terminal Shape
A	SMD Type
L	Lead Type

- ④ Total Resistance

Expressed by three figures. The unit is ohm. The first and second figures are significant digits, and the third figure expresses the number of zeros which follow the two figures.

Ex.)

Code	Total Resistance
103	10000Ω (=10kΩ)

- ⑤ Rotor Hole Shape/Rotor Hole Size

Code	Rotor Hole Shape/Rotor Hole Size
AD	D Hole/3.5mm Dia.
AE	D Hole/4.0mm Dia.
CE	T Hole/4.0mm Dia.

- ⑥ Individual Specification Code
- ⑦ Packaging

Rotary Sensors



- ① Product ID
- ② Type
- ③ Characteristics
- ④ Individual Specification Code

* "(Part Number)" shows only an example which might be different from actual part number.
 * Any other definitions than "① Product ID" might have different digit number from actual part number.

Magnetic Pattern Recognition Sensors

(Part Number) **BS** **05W** **1KFAA**

① ② ③ ④

- ① Product ID
- ② Type
- ③ Characteristics
- ④ Individual Specification Code

* "(Part Number)" shows only an example which might be different from actual part number.
 * Any other definitions than "① Product ID" might have different digit number from actual part number.

Magnetic Switch

(Part Number) **AS-** **M** **15** **T** **A** **-R**

① ② ③ ④ ⑤ ⑥ ⑦

- ① Product ID
- ② Type

Code	Type
M	Magnetic Switch
R	Rotational Sensor

- ③ Sensitivity

Code	Sensitivity
15	1.5mT
30	3.0mT

- ④ Package

Code	Package
T	SOT23
N	SON4

- ⑤ Supply Voltage

Code	Supply Voltage
A	1.6 to 3.5V
B	3.6 to 6.0V

- ⑥ Individual Specification Code
- ⑦ Packaging

* "(Part Number)" shows only an example which might be different from actual part number.
 * Any other definitions than "① Product ID" might have a different digit number from actual part number.

	Detection	Temp- erature	Infra- red	Ultra- sonic	Magnetic		Mechanical		
							Accele- ration	Angle Velocity	Angle
	Murata's Sensors	PTC Thermistors (POSISTOR®)	Pyroelectric Infrared Sensors	Ultrasonic Sensors	Rotary Sensors	Magnetic Pattern Recognition Sensors	Shock Sensors	Gyro Sensors	Rotary Position Sensors
Audio Visual Equipment	TV	○	○	○					
	Audio Equipment	○	○						
	DVD, MD, CD	○					○		○
	VCR	○							
	Video Cameras	○					○	○	○
	Cameras, Digital Cameras	○					○	○	○
Home Appliances	Refrigerators								○
	Air Conditioners	○	○						○
	Vacuum Cleaners	○							
	Kitchen Fans		○						
	Water Suppliers								○
Security	Gas Detection Sensors	○	○						
	Flame Detection (heat) Sensors		○						
	Flammable Sensors		○						
	Burglar Alarm Systems	○	○	○					
	Intruders Detection Sensors		○	○					
	Glass Cracking Detection Sensors			○					
Factory Automation Equipment	Automatic Transportation Systems			○				○	○
	Multi-Joints Robots				○			○	○
	Processing Machines				○				
	Shape Inspection Systems			○					
	Molding Machines				○				
Automotive	Navigation	○						○	○
	Air Conditioners	○							○
	Back Sonars			○					
Office Automation Equipment	Personal Computers	○	○				○	○	
	Copying Machines	○	○	○					○
	Printers	○	○	○					
	Facsimiles	○	○	○					
	Electric Boards			○					
Financial Systems	Automatic Teller Machines			○		○			

PTC (POSISTOR®) for Overheat Sensing

Chip Type 0402 (1005) Size

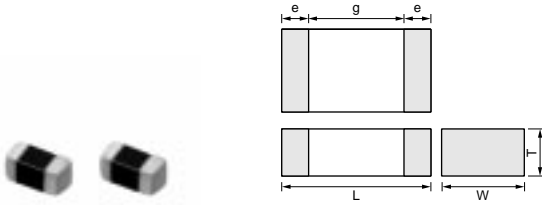

Part Number	Dimensions (mm)				
	L	W	T	e	g
PRF15_RC	1.0±0.05	0.5±0.05	0.5±0.05	0.15 to 0.4	0.3 min.
PRF18_RB	1.6±0.15	0.8±0.15	0.8±0.15	0.1 to 0.6	-
PRF21_RA	2.0±0.2	1.25±0.2	0.9±0.2	0.2 min.	0.5 min.

Part Number	Sensing Temperature (at 4.7k ohm) (°C)	Maximum Voltage (V)	Resistance (25°C) (ohm)	Operating Temperature Range (°C)
PRF15BC471QB1RC	105 ±5°C	32	470 ±50%	-20 to 120
PRF15BB471QB1RC	115 ±5°C	32	470 ±50%	-20 to 130
PRF15BA471QB1RC	125 ±5°C	32	470 ±50%	-20 to 140

This product is applied to reflow soldering.
This product is recognized by UL.

PTC (POSISTOR®) for Overheat Sensing

Chip Type 0603 (1608) Size

Part Number	Sensing Temperature (at 4.7k ohm) (°C)	Sensing Temperature (at 47k ohm) (°C)	Maximum Voltage (V)	Resistance (25°C) (ohm)	Operating Temperature Range (°C)
PRF18BG471QB5RB	65 ±5°C	80 ±7°C	32	470 ±50%	-20 to 90
PRF18BF471QB5RB	75 ±5°C	90 ±7°C	32	470 ±50%	-20 to 100
PRF18BE471QB5RB	85 ±5°C	100 ±7°C	32	470 ±50%	-20 to 110
PRF18BD471QB5RB	95 ±5°C	110 ±7°C	32	470 ±50%	-20 to 120
PRF18BC471QB5RB	105 ±5°C	120 ±7°C	32	470 ±50%	-20 to 130
PRF18BB471QB5RB	115 ±5°C	130 ±7°C	32	470 ±50%	-20 to 140
PRF18BA471QB5RB	125 ±5°C	140 ±7°C	32	470 ±50%	-20 to 150
PRF18AR471QB5RB	135 ±5°C	150 ±7°C	32	470 ±50%	-20 to 160
PRF18AS471QB5RB	145 ±5°C	-	32	470 ±50%	-20 to 160

This product is applied to flow/reflow soldering.
This product is recognized by UL.

PTC (POSISTOR®) for Overheat Sensing

Chip Type 0805 (2012) Size

Part Number	Sensing Temperature (at 4.7k ohm) (°C)	Maximum Voltage (V)	Resistance (25°C) (ohm)	Operating Temperature Range (°C)
PRF21BE471QB5RA	85 ±5°C	32	470 ±50%	-20 to 100
PRF21BD471QB5RA	95 ±5°C	32	470 ±50%	-20 to 110
PRF21BC471QB5RA	105 ±5°C	32	470 ±50%	-20 to 120
PRF21BB471QB5RA	115 ±5°C	32	470 ±50%	-20 to 130
PRF21BA471QB5RA	125 ±5°C	32	470 ±50%	-20 to 140
PRF21AR471QB5RA	135 ±5°C	32	470 ±50%	-20 to 150
PRF21AS471QB5RA	145 ±5°C	32	470 ±50%	-20 to 160

This product is applied to flow/reflow soldering.
This product is recognized by UL.

⚠Note • This PDF catalog is downloaded from the website of Murata Manufacturing co., Ltd. Therefore, it's specifications are subject to change or our products in it may be discontinued without advance notice. Please check with our sales representatives or product engineers before ordering.
• This PDF catalog has only typical specifications because there is no space for detailed specifications. Therefore, please approve our product specifications or transact the approval sheet for product specifications before ordering.

PTC (POSISTOR[®]) for Overheat Sensing

Chip Tight Tolerance Type 0402(1005) Size

Part Number	Sensing Temperature (at 4.7M ohm) (°C)	Maximum Voltage (V)	Resistance (25°C) (k ohm)	Operating Temperature Range (°C)
PRF15BE103RB6RC	100 ±3°C	32	10 ±50%	-20 to 110
PRF15BG103RB6RC	80 ±3°C	32	10 ±50%	-20 to 90

This product is applied to reflow soldering.

PTC (POSISTOR[®]) for Overheat Sensing

Chip Tight Tolerance Type 0603 (1608) Size

Part Number	Sensing Temperature (at 4.7k ohm) (°C)	Maximum Voltage (V)	Resistance (25°C) (ohm)	Operating Temperature Range (°C)
PRF18BG471RB5RB	65 ±3°C	32	470 ±50%	-20 to 80
PRF18BF471RB5RB	75 ±3°C	32	470 ±50%	-20 to 90
PRF18BE471RB5RB	85 ±3°C	32	470 ±50%	-20 to 100
PRF18BD471RB5RB	95 ±3°C	32	470 ±50%	-20 to 110
PRF18BC471RB5RB	105 ±3°C	32	470 ±50%	-20 to 120
PRF18BB471RB5RB	115 ±3°C	32	470 ±50%	-20 to 130

This product is applied to flow/reflow soldering.

This product is recognized by UL.

PTC (POSISTOR[®]) for Overheat Sensing

Lead Type

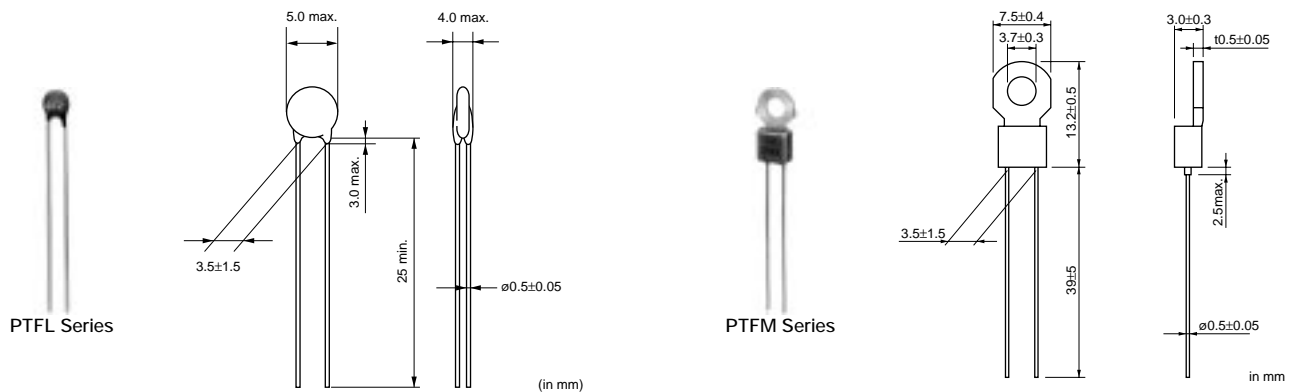

Part Number	Max. Voltage (V)	Sensing Temp. (TS) (°C)	Resistance Value at 25°C (max.) (ohm)	Resistance Value (TS -10°C) (max.) (ohm)	Resistance Value (TS°C) (min.) (ohm)
PTF□04BH471Q2N34B0	16	60	100	330	470
PTF□04BG471Q2N34B0	16	70	100	330	470
PTF□04BF471Q2N34B0	16	80	100	330	470
PTF□04BE471Q2N34B0	16	90	100	330	470
PTF□04BD471Q2N34B0	16	100	100	330	470
PTF□04BC471Q2N34B0	16	110	100	330	470
PTF□04BB471Q2N34B0	16	120	100	330	470
PTF□04BH222Q2N34B0	16	60	330	1.5k	2.2k
PTF□04BG222Q2N34B0	16	70	330	1.5k	2.2k
PTF□04BF222Q2N34B0	16	80	330	1.5k	2.2k
PTF□04BE222Q2N34B0	16	90	330	1.5k	2.2k
PTF□04BD222Q2N34B0	16	100	330	1.5k	2.2k
PTF□04BC222Q2N34B0	16	110	330	1.5k	2.2k

Continued on the following page.

△Note • This PDF catalog is downloaded from the website of Murata Manufacturing co., ltd. Therefore, it's specifications are subject to change or our products in it may be discontinued without advance notice. Please check with our sales representatives or product engineers before ordering.
• This PDF catalog has only typical specifications because there is no space for detailed specifications. Therefore, please approve our product specifications or transact the approval sheet for product specifications before ordering.

Continued from the preceding page.

Part Number	Max. Voltage (V)	Sensing Temp. (TS) (°C)	Resistance Value at 25°C (max.) (ohm)	Resistance Value (TS -10°C) (max.) (ohm)	Resistance Value (TS°C) (min.) (ohm)
PTF□04BB222Q2N34B0	16	120	330	1.5k	2.2k

A blank is filled with type codes. (L: Lead type, M: with Lug-terminal)
Operating temperature range is -10 to TS+10°C.
Please contact us for UL recognized products.

Pyroelectric Infrared Sensors

Pyroelectric Infrared Sensors

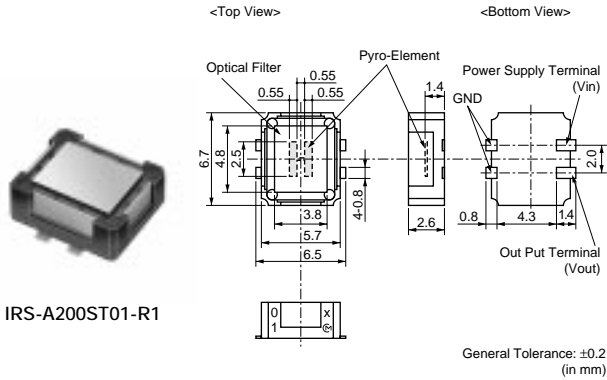

Part Number	Field of View	Optical Filter	Electrode	Operating Temperature Range (°C)
IRS-A330ST02-R1	theta1=theta2=50deg.	5X10**-6m Long Pass	(1x0.55mm)x4	-40 to 70
IRS-A200ST01-R1	theta1=theta2=50deg.	5X10**-6m Long Pass	(2.5x0.55mm)x2	-40 to 70

Pyroelectric Infrared Sensors

Fresnel Lens

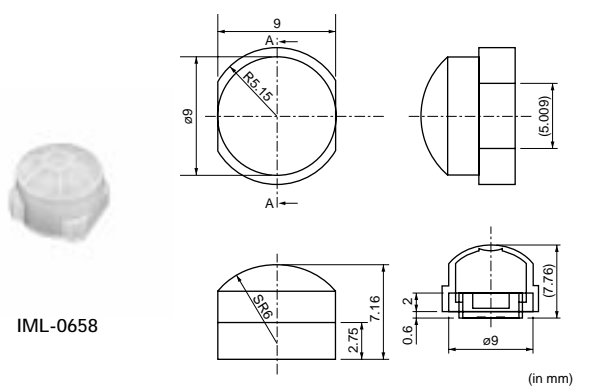
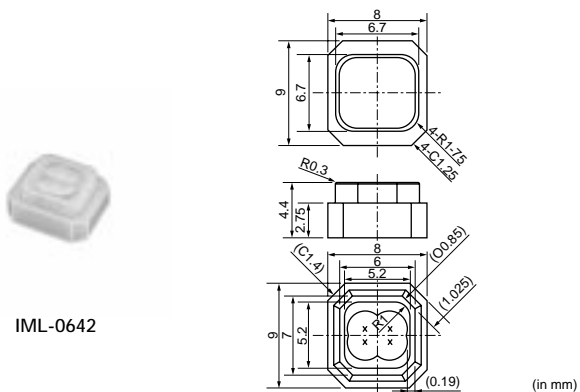

Continued on the following page.

Note • This PDF catalog is downloaded from the website of Murata Manufacturing co., ltd. Therefore, it's specifications are subject to change or our products in it may be discontinued without advance notice. Please check with our sales representatives or product engineers before ordering.
• This PDF catalog has only typical specifications because there is no space for detailed specifications. Therefore, please approve our product specifications or transact the approval sheet for product specifications before ordering.

Continued from the preceding page.



PPGI0601

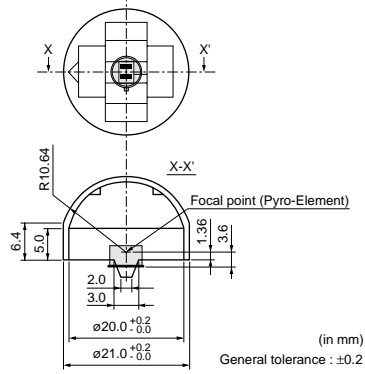

PPGI0626

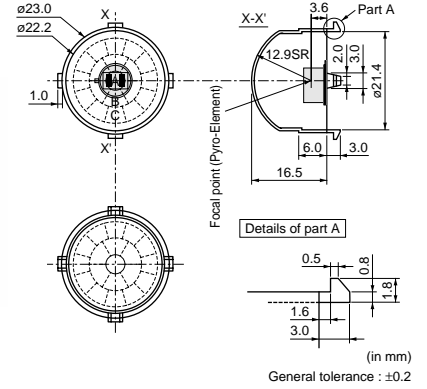

PPGI0902

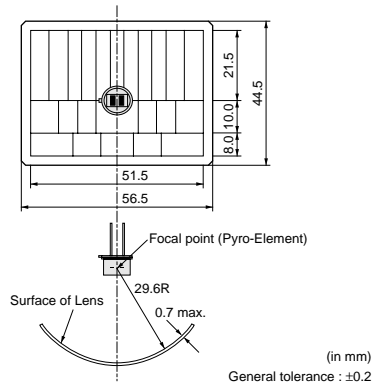

Part Number	Material	Color	Operating Temperature Range (°C)
IMD-FL01G	High density polyethylene	Dark Gray	-20 to 60
IMD-FL01W	High density polyethylene	Natural(White)	-20 to 60
IML-0642	High density polyethylene	Natural(White)	-25 to 60
IML-0658	High density polyethylene	Natural(White)	-25 to 60
IML-0669	High density polyethylene	Natural(White)	-25 to 60
PPGI0601	High density polyethylene	Natural(White)	-25 to 55
PPGI0626	High density polyethylene	Natural(White)	-25 to 55
PPGI0902	High density polyethylene	Natural(White)	-20 to 60

Ultrasonic Sensors

● Open Structure Type



MA40S4R

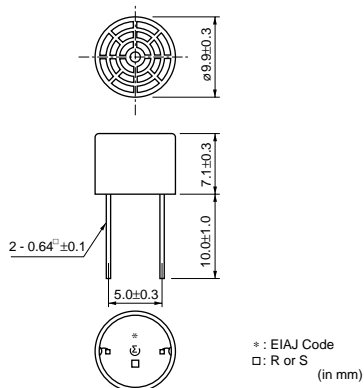

Directivity in Sensitivity

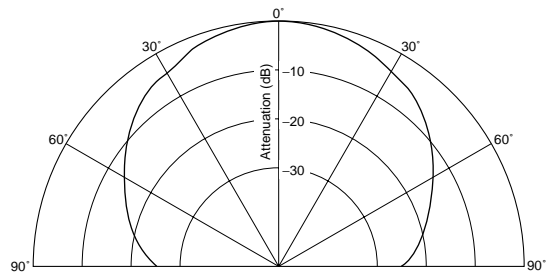

Continued on the following page.

Note • This PDF catalog is downloaded from the website of Murata Manufacturing co., ltd. Therefore, it's specifications are subject to change or our products in it may be discontinued without advance notice. Please check with our sales representatives or product engineers before ordering.
• This PDF catalog has only typical specifications because there is no space for detailed specifications. Therefore, please approve our product specifications or transact the approval sheet for product specifications before ordering.

Continued from the preceding page.



MA40S4S

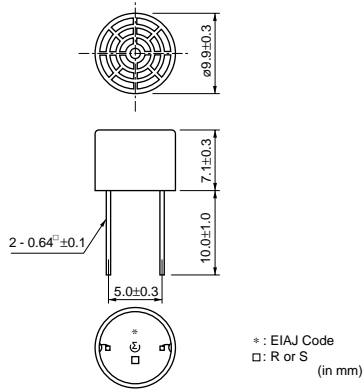

Directivity in S.P.L.

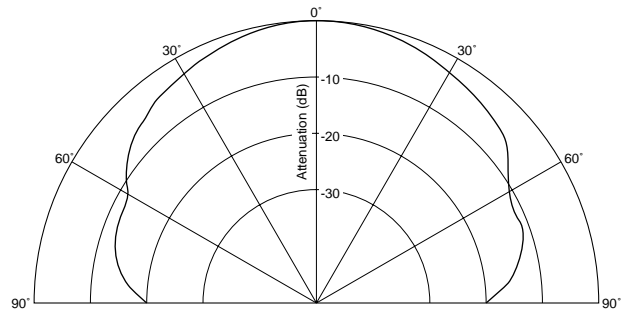

Part Number	Construction	Using Method	Nominal Freq. (kHz)	Overall Sensitivity	Sensitivity (dB)	S.P.L. (dB)	Directivity (°)	Cap. (pF)
MA40S4R	Open struct.	Receiver	40	-	-63 typ. (0dB=10V/Pa)	-	80 (typ.)	2550
MA40S4S	Open struct.	Transmitter	40	-	-	120 typ. (0dB=0.02mPa)	80 (typ.)	2550

● Water Proof Type



MA40MF14-5B

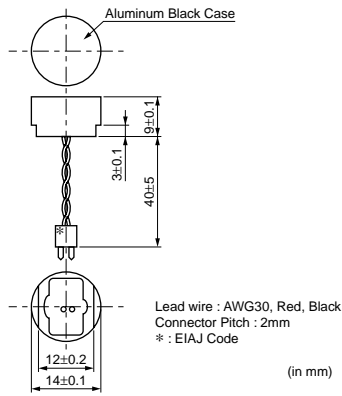

Directivity in Overall Sensitivity

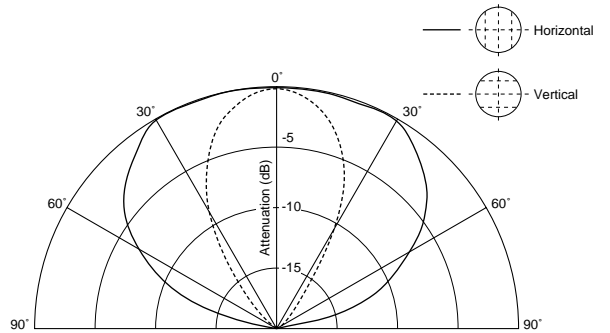

MA48MF14-5B

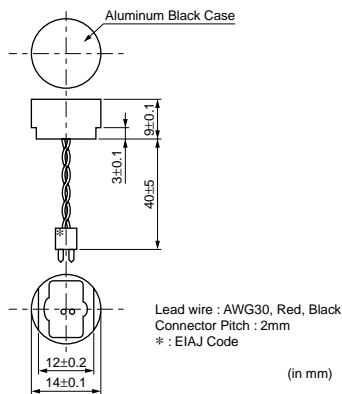

Directivity in Overall Sensitivity

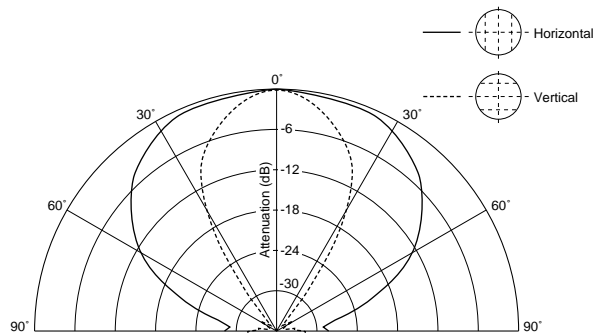

Continued on the following page. ↗

⚠Note • This PDF catalog is downloaded from the website of Murata Manufacturing co., ltd. Therefore, it's specifications are subject to change or our products in it may be discontinued without advance notice. Please check with our sales representatives or product engineers before ordering.
• This PDF catalog has only typical specifications because there is no space for detailed specifications. Therefore, please approve our product specifications or transact the approval sheet for product specifications before ordering.

Continued from the preceding page.

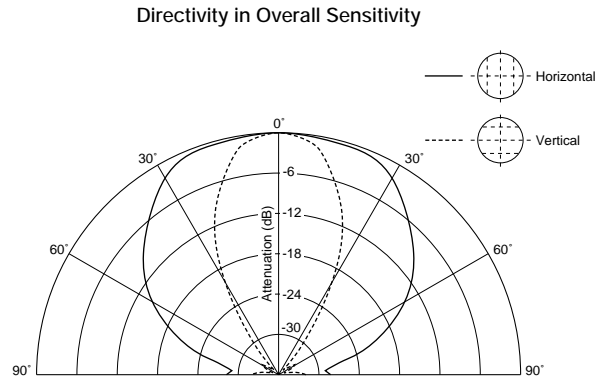
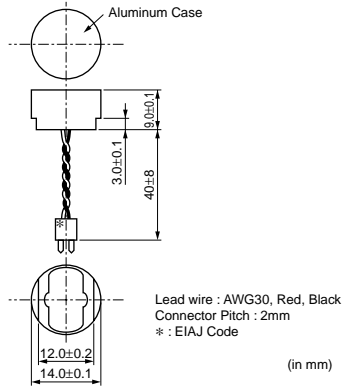

Part Number	Construction	Using Method	Nominal Freq. (kHz)	Overall Sensitivity	Sensitivity (dB)	S.P.L. (dB)	Directivity (°)	Cap. (pF)
MA40MF14-5B	Water proof	Dual Use	40	-	-87 min. (0dB=10V/Pa)	103 min. (0dB=0.02mPa)	110 x50°(typ.)	4400
MA48MF14-5B	Water proof	Dual Use	48	-	-90 min. (0dB=10V/Pa)	101 min. (0dB=0.02mPa)	100 x40°(typ.)	4200
MA58MF14-0N	Water proof	Dual Use	58	0.3 to 1.2 vop	-	-	80 x35°(typ.)	2000

● High Frequency Type

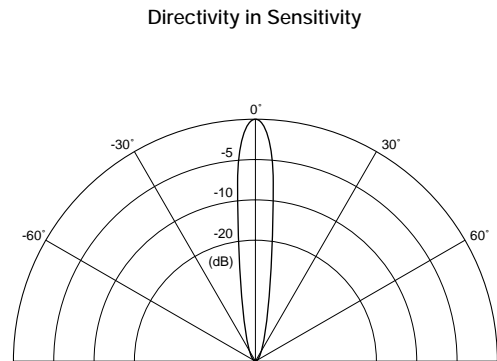
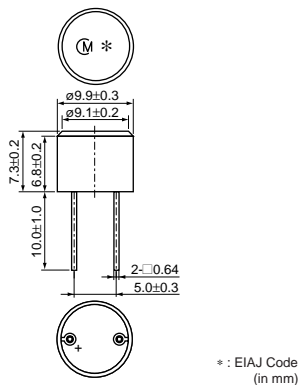
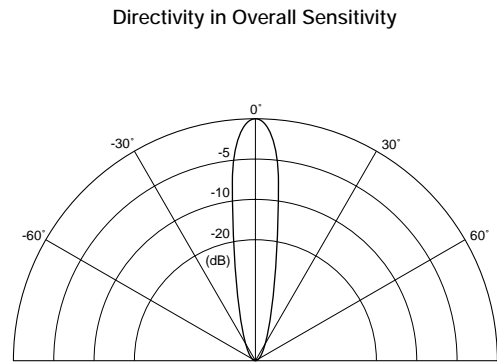
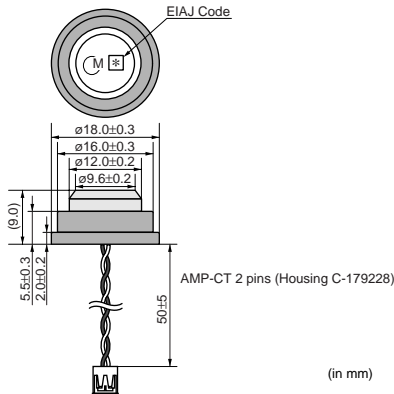

Part Number	Construction	Using Method	Nominal Freq. (kHz)	Overall Sensitivity	Sensitivity	S.P.L.	Directivity (°)	Cap. (pF)
MA200D1-1	High frequency type	Dual Use	220	from 1.0V to 2.5V	-	-	20 (max.)	2300
MA300D1-1	High frequency type	Dual Use	300	Min.1.5V	-	-	11 (max.)	1300

△Note • This PDF catalog is downloaded from the website of Murata Manufacturing co., ltd. Therefore, it's specifications are subject to change or our products in it may be discontinued without advance notice. Please check with our sales representatives or product engineers before ordering.
• This PDF catalog has only typical specifications because there is no space for detailed specifications. Therefore, please approve our product specifications or transact the approval sheet for product specifications before ordering.

Shock Sensors

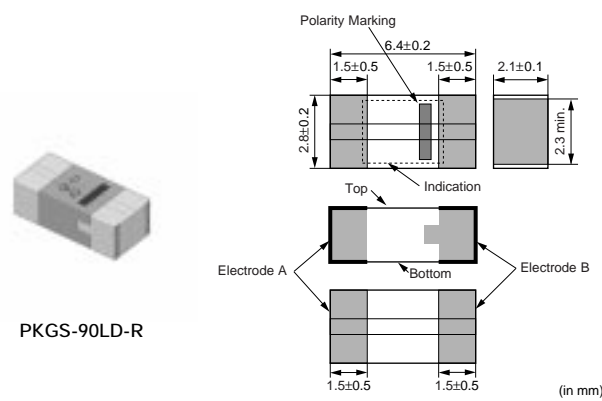
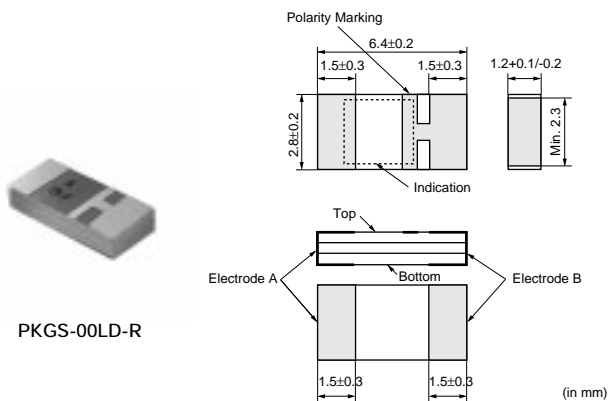
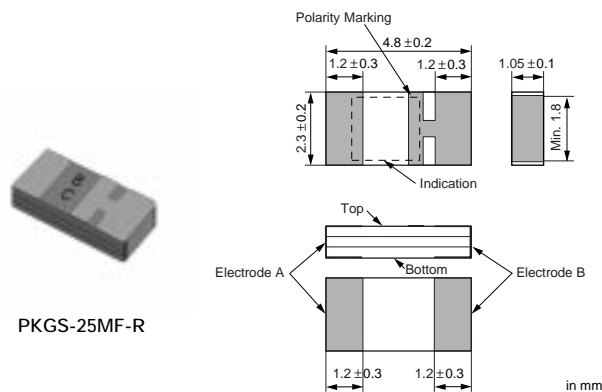
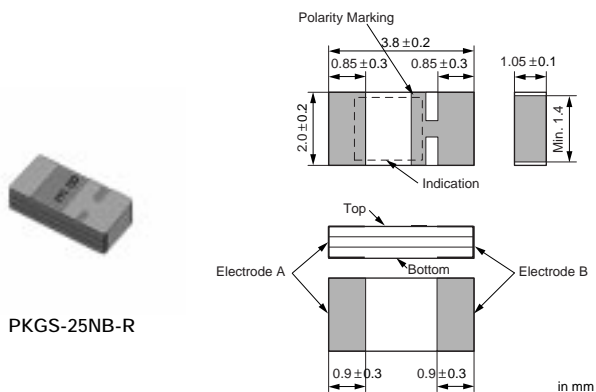

Part Number	Type of Sensitivity	Primary Axis Inclined Angle (°)	Sensitivity* (Typ.) (pC/G)	Capacitance (Typ.) (pF)	Resonant Frequency (Typ.) (kHz)
PKGS-25NB-R	Electric charge sensitivity type	25	0.168	520	44
PKGS-00MF-R	Electric charge sensitivity type	0	0.325	570	27
PKGS-25MF-R	Electric charge sensitivity type	25	0.350	610	27
PKGS-00LD-R	Electric charge sensitivity type	0	0.840	770	20
PKGS-90LD-R	Electric charge sensitivity type	90	0.840	770	20

*1G=9.80665m/s²

Gyro Sensors

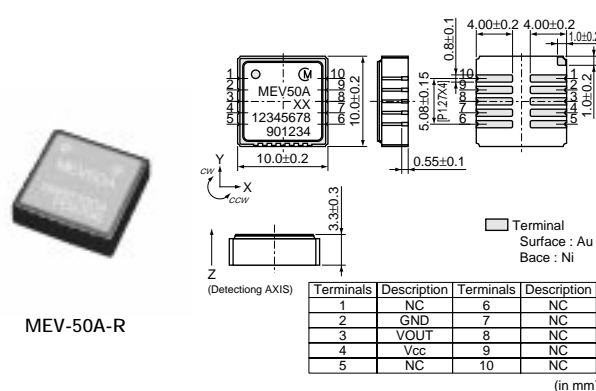
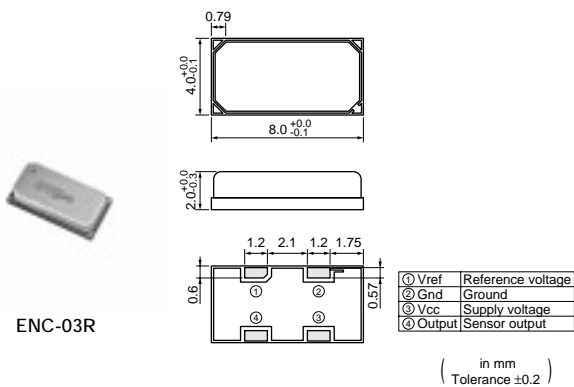

- ① Vref Reference voltage
- ② Gnd Ground
- ③ Vcc Supply voltage
- ④ Output Sensor output

Terminals	Description	Terminals	Description
1	NC	6	NC
2	GND	7	NC
3	VOUT	8	NC
4	Vcc	9	NC
5	NC	10	NC

Note • This PDF catalog is downloaded from the website of Murata Manufacturing co., Ltd. Therefore, it's specifications are subject to change or our products in it may be discontinued without advance notice. Please check with our sales representatives or product engineers before ordering.
• This PDF catalog has only typical specifications because there is no space for detailed specifications. Therefore, please approve our product specifications or transact the approval sheet for product specifications before ordering.

Part Number	Supply Voltage (Vdc)	Maximum Angular Velocity (deg./sec.)	Output (at Angular Velocity=0) (Vdc)	Scale Factor (mV/deg./sec.)	Linearity (%FS)	Response (Hz)	Operating Temperature Range (°C)	Mass (max.) (g)
ENC-03R	2.7 to 5.25	+/-300	1.35	0.67	+/-5	50	-5 to 75	0.2
MEV-50A-R	5 +/-0.25	+/- 70	2.5 +/-0.3	25.0	0.5	-	-40 to 85	1.5

Rotary Position Sensors

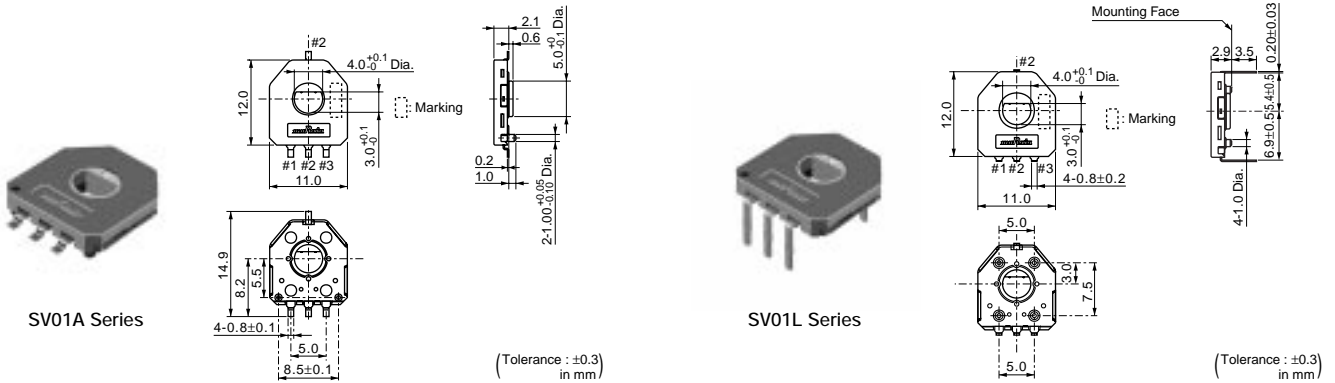

Part Number	Total Resistance Value (k ohm)	Linearity (%)	Effective Rotational Angle	Rotational Life
SV01A103AEA01	10 ±30%	±2	333.3° (Ref.)	1M cycles
SV01L103AEA11	10 ±30%	±2	333.3° (Ref.)	1M cycles

Operating Temperature Range: -40°C to 85°C

The order quantity should be an integral multiple of the "Minimum Quantity" shown in the beginning of this catalog.

Rotary Sensors

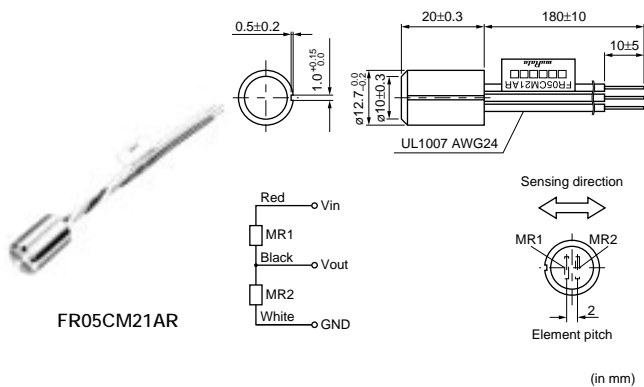

Part Number	Output Type	Target Gear Module
FR05CM21AR	Single	0.3-1.0

△Note • This PDF catalog is downloaded from the website of Murata Manufacturing co., ltd. Therefore, it's specifications are subject to change or our products in it may be discontinued without advance notice. Please check with our sales representatives or product engineers before ordering.
• This PDF catalog has only typical specifications because there is no space for detailed specifications. Therefore, please approve our product specifications or transact the approval sheet for product specifications before ordering.

Magnetic Pattern Recognition Sensors

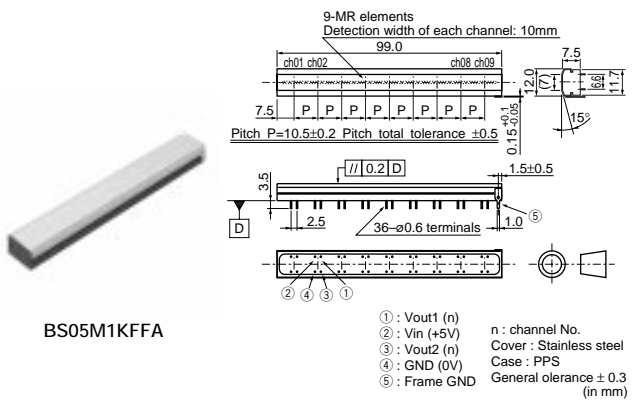
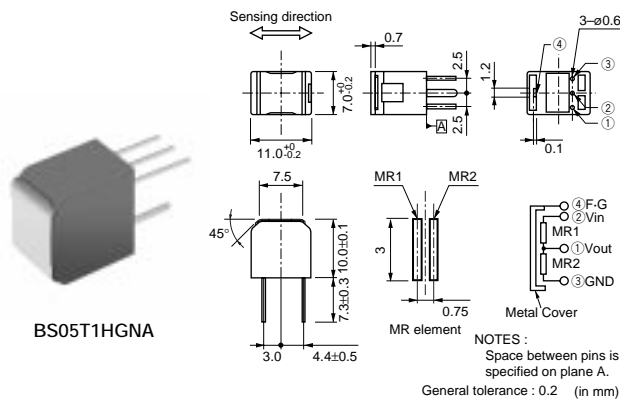
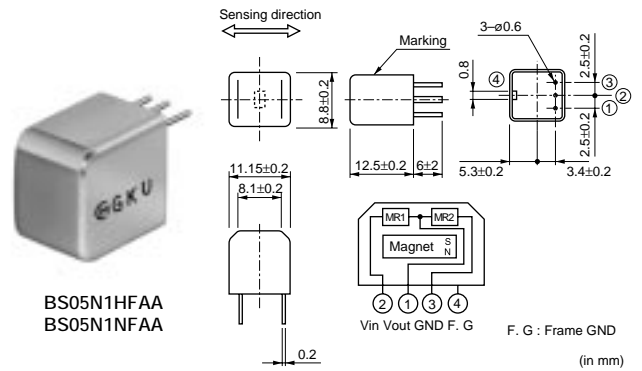
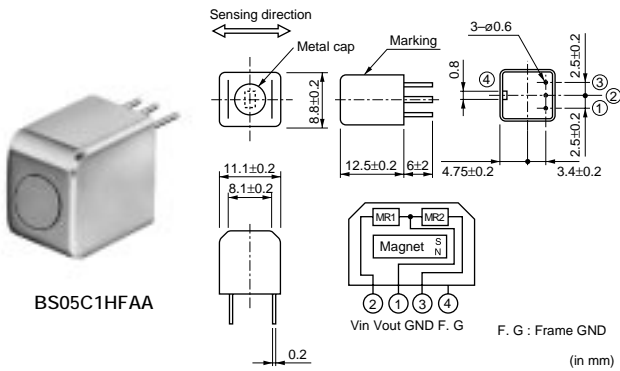

Part Number	Supply Voltage (V)	Min. Output Voltage	Max. Output Voltage	Detection Width (mm)	Operating Temperature Range (°C)
BS05C1HFAA	5	400mV rms	-	3	-20 to 60
BS05N1HFAA	5	400mV rms	-	3	-20 to 60
BS05T1HGNA	5	200mV rms	400mV rms	3	-20 to 60
BS05N1NFAA	5	330mV rms	-	6	-20 to 60
BS05M1KFFA	5	100mV p-p	-	10	0 to 50

Magnetic Switch

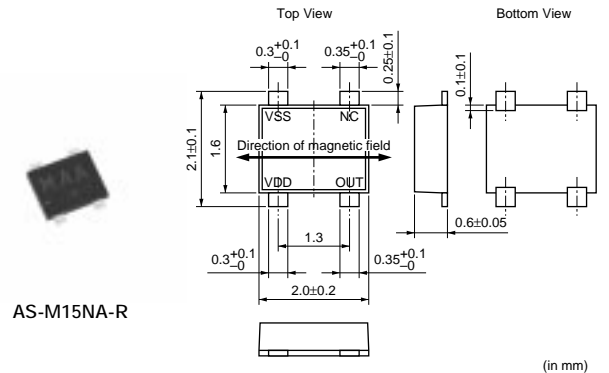
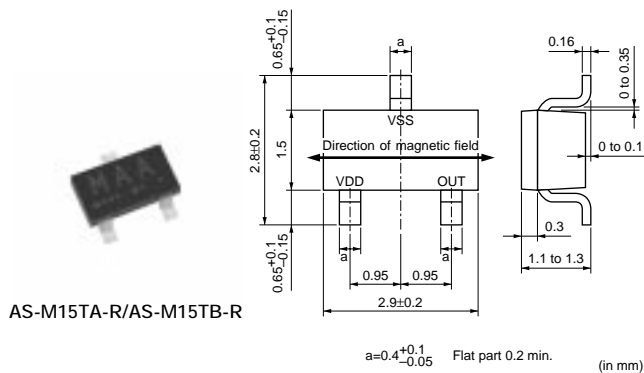

Part Number	Supply Voltage	Current Consumption	Operating Magnetic Field (H->L)	Operating Magnetic Field (L->H)
AS-M15TA-R	1.6 to 3.5V	1.6 to 3.0 μ A	1.5 to 2.2mT	0.8 to 1.2mT
AS-M15TB-R	1.6 to 3.5V	1.6 to 3.0 μ A	1.5 to 2.2mT	0.8 to 1.2mT
AS-M15NA-R	1.6 to 3.5V	1.6 to 3.0 μ A	1.5 to 2.2mT	0.8 to 1.2mT

10

Thermistors

PTC Thermistors (POSISTOR[®]) for Heater

PTC Thermistors (POSISTOR[®]) for Circuit Protection

PTC Thermistors (POSISTOR[®]) for Overheat Sensing

PTC Thermistors (POSISTOR[®]) for Motor Starters

NTC Thermistors for Temp. Sensor and Compensation

NTC Thermistors for Inrush Current Suppression

● **Part Numbering**

PTC Thermistors (POSISTOR®) for Heater

(Part Number) **PT** **WSB1** **AS** **201** **T** **260** **A00**
 ① ② ③ ④ ⑤ ⑥ ⑦

- ① Product ID
- ② Series
- ③ Temperature Characteristics

Code	Temperature Characteristics
AD	Curie Point 280°C
AG	Curie Point 220°C
AH	Curie Point 200°C
AS	Curie Point 130°C
BC	Curie Point 90°C

- ④ Resistance
- Expressed by three figures. The unit is ohm (Ω). The first and second figures are significant digits, and the third figure expresses the number of zeros which follow the two figures.

Ex.)

Code	Resistance
201	200 Ω

- ⑤ Resistance Tolerance
- ⑥ Maximum Voltage
- ⑦ Individual Specifications

PTC Thermistors (POSISTOR®) for Circuit Protection

(Part Number) **PR** **G** **18** **BB** **470** **M** **B1** **RB**
 ① ② ③ ④ ⑤ ⑥ ⑦ ⑧

- ① Product ID
- ② Series
- ③ Dimensions (L×W)
- ④ Temperature Characteristics
- ⑤ Resistance

Expressed by three-digit alphanumerics. The unit is ohm (Ω). The first and second figures are significant digits, and the third figure expresses the number of zeros which follow the two figures. If there is a decimal point, it is expressed by the capital letter "R". In this case, all figures are significant digits.

Ex.)

Code	Resistance
470	47 Ω
471	470 Ω

- ⑥ Resistance Tolerance
- ⑦ Individual Specifications
- ⑧ Packaging

Code	Packaging
RA	Embossed Taping 4mm Pitch (4000 pcs.)
RB	Paper Taping 4mm Pitch (4000 pcs.)
RK	Embossed Taping 4mm Pitch (3000 pcs.)

PTC Thermistors (POSISTOR®) for Circuit Protection / for Overheat Sensing Lead Type

(Part Number) **PT** **GL** **07** **AR** **220** **M** **3P51** **A0**
 ① ② ③ ④ ⑤ ⑥ ⑦ ⑧

- ① Product ID
- ② Series
- ③ Dimensions
- ④ Temperature Characteristics
- ⑤ Resistance

Expressed by three-digit alphanumerics. The unit is ohm (Ω). The first and second figures are significant digits, and the third figure expresses the number of zeros which follow the two figures. If there is a decimal point, it is expressed by the capital letter "R". In this case, all figures are significant digits.

Ex.)

Code	Resistance
R22	0.22 Ω
2R2	2.2 Ω
220	22 Ω

- ⑥ Resistance Tolerance
- ⑦ Individual Specifications
- ⑧ Packaging

Code	Packaging
A0	Ammo Pack
B0	Bulk

PTC Thermistors (POSISTOR®) for Overheat Sensing Chip Type

(Part Number) **PR** **F** **18** **BB** **471** **Q** **B5** **RB**
 ① ② ③ ④ ⑤ ⑥ ⑦ ⑧

- ① Product ID
- ② Series
- ③ Dimensions (L×W)
- ④ Temperature Characteristics

Code	Temperature Characteristics
AR	Curie Point 120°C
AS	Curie Point 130°C
BA	Curie Point 110°C
BB	Curie Point 100°C
BC	Curie Point 90°C
BD	Curie Point 80°C
BE	Curie Point 70°C
BF	Curie Point 60°C
BG	Curie Point 50°C

- ⑤ Resistance
- Expressed by three figures. The unit is ohm (Ω). The first and second figures are significant digits, and the third figure expresses the number of zeros which follow the two figures.

Ex.)

Code	Resistance
471	470 Ω

- ⑥ Resistance Tolerance



⑦ Individual Specifications

⑧ Packaging

Code	Packaging
RA	Embossed Taping 4mm Pitch (4000 pcs.)
RB	Paper Taping 4mm Pitch (4000 pcs.)
RC	Paper Taping 2mm Pitch (10000 pcs.)

PTC Thermistors (POSISTOR®) for Motor Starter Plug-in Type

(Part Number) **PT** **H7M** **4R7** **M** **C1** **-00**
 ① ② ③ ④ ⑤ ⑥

① Product ID

② Series

③ Resistance

Expressed by three-digit alphanumerics. The unit is ohm (Ω). The first and second figures are significant digits, and the third figure expresses the number of zeros which follow the two figures. If there is a decimal point, it is expressed by the capital letter "R". In this case, all figures are significant digits.

Ex.)

Code	Resistance
4R7	4.7 Ω
470	47 Ω

④ Resistance Tolerance

⑤ Starting Circuit

Code	Starting Circuit
B3	CSR 3Pin
C1	RSIR 1Pin
C2	RSIR 2Pin
D2	RSCR 2Pin
D3	RSCR 3Pin

Please contact us for details.

⑥ Individual Specifications

NTC Thermistors for Temp. Sensor and Compensation Chip Type

(Part Number) **NC** **P** **18** **XH** **103** **J** **03** **RB**
 ① ② ③ ④ ⑤ ⑥ ⑦ ⑧

① Product ID

② Series

③ Dimensions (LXW)

④ Temperature Characteristics

⑤ Resistance

Expressed by three figures. The unit is ohm (Ω). The first and second figures are significant digits, and the third figure expresses the number of zeros which follow the two figures.

Ex.)

Code	Resistance
102	1k Ω
103	10k Ω
104	100k Ω



⑥ Resistance Tolerance

⑦ Individual Specifications

⑧ Packaging

Code	Packaging
RA	Embossed Taping 4mm Pitch (4000 pcs.)
RB	Paper Taping 4mm Pitch (4000 pcs.)
RC	Paper Taping 2mm Pitch (10000 pcs.)
RL	Paper Taping 2mm Pitch (15000 pcs.)

NTC Thermistors for Inrush Current Suppression

(Part Number) **NT** **PAN** **3R0** **L** **DK** **B0**
 ① ② ③ ④ ⑤ ⑥

① Product ID

② Series

③ Resistance

Expressed by three-digit alphanumerics. The unit is ohm (Ω). The first and second figures are significant digits, and the third figure expresses the number of zeros which follow the two figures. If there is a decimal point, it is expressed by the capital letter "R". In this case, all figures are significant digits.

Ex.)

Code	Resistance
3R0	3 Ω
100	10 Ω

④ Resistance Tolerance

⑤ Individual Specifications

A lead structure and other specifications are expressed by two capital letters.

Code	Individual Specifications	Body Diameter
B1	Standard Type (Ammo Pack)	ϕ 7mm, ϕ 9mm
BM	Standard Type (Bulk)	ϕ 7mm, ϕ 9mm
D6	Standard Type (Ammo Pack)	ϕ 10mm, ϕ 13mm
DK	Standard (Bulk)	ϕ 18mm, ϕ 22mm
DN	Standard (Bulk)	ϕ 10mm, ϕ 13mm

⑥ Packaging

Code	Packaging
A0	Ammo Pack Taping
B0	Bulk

△Note • This PDF catalog is downloaded from the website of Murata Manufacturing co., Ltd. Therefore, it's specifications are subject to change or our products in it may be discontinued without advance notice. Please check with our sales representatives or product engineers before ordering.
 • This PDF catalog has only typical specifications because there is no space for detailed specifications. Therefore, please approve our product specifications or transact the approval sheet for product specifications before ordering.

PTC (POSISTOR®) for Heater

Standard Type

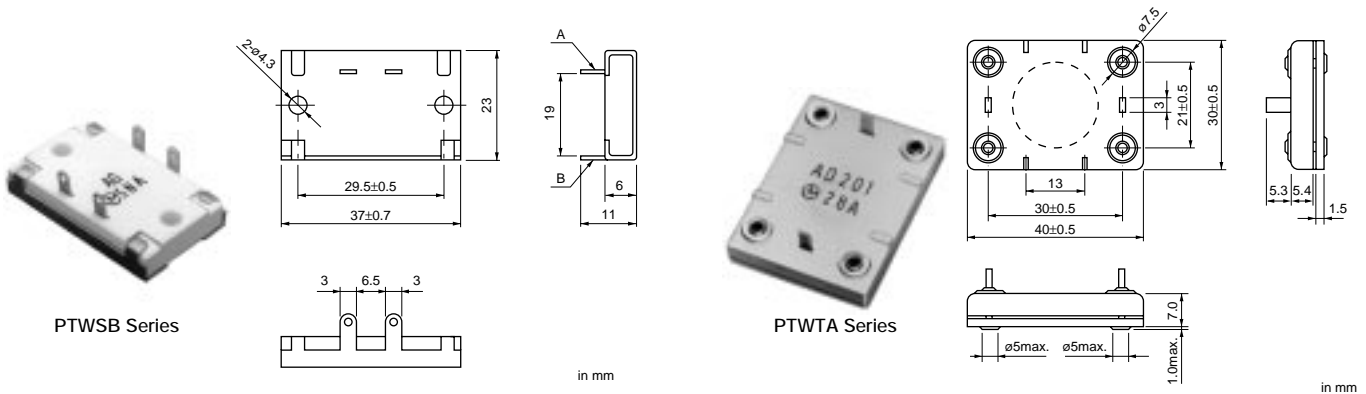

Part Number	Curie Point (°C)	Rated Volt. (Vrms)	Max. Volt. (Vrms)	Inrush Current (max.) (A)	Steady State Current (at 120Vrms) (mA)	Steady State Current (at 220Vrms) (mA)	Surface Temp. (Nominal Value) (°C)
PTWSB1BC201T260A00	92 ±7	120/220.	260	5.0	28 ±20%	17 ±20%	105
PTWSB1AS201T260A00	135 ±7	120/220.	260	5.0	33 ±20%	21 ±20%	130
PTWSB2AH201T260A00	207 ±7	120/220.	260	5.0	58 ±20%	35 ±20%	185
PTWSB2AG201T260A00	225 ±7	120/220.	260	5.0	65 ±20%	39 ±20%	200
PTWTA1AD201T260A00	280 ±7	120/220.	260	10.0	-	75 ±30%	285

Inrush current based on 220Vrms.

Operating temperature range PTWSB1: -20°C to +60°C, PTWSB2: -20°C to +85°C, PTWTA: 0°C to +60°C

PTC (POSISTOR®) for Circuit Protection

Chip Type 0603 (1608) Size

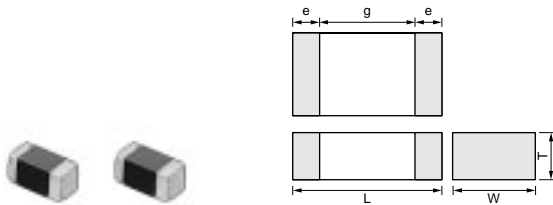

Part Number	Dimensions (mm)				
	L	W	T	e	g
PRG18_RB	1.6±0.15	0.8±0.15	0.8±0.15	0.1 to 0.6	-
PRG21_RA	2.0±0.2	1.25±0.2	0.9±0.2	0.2 min.	0.5 min.
PRG21_RK	2.0±0.2	1.25±0.2	1.25±0.2	0.2 min.	0.5 min.

Part Number	Max. Voltage (V)	Hold Current (at +60°C) (mA)	Hold Current (at +25°C) (mA)	Trip Current (at +25°C) (mA)	Trip Current (at -10°C) (mA)	Max. Current (mA)	Resistance (at +25°C) (ohm)
PRG18BB471MB1RB	24	7	10	21	25	60	470 ±20%
PRG18BB221MB1RB	24	10	14	29	35	130	220 ±20%
PRG18BB101MB1RB	24	15	21	45	55	300	100 ±20%
PRG18BB470MB1RB	24	20	29	61	75	630	47 ±20%
PRG18BB330MB1RB	24	25	36	71	85	900	33 ±20%
PRG18BC6R8MM1RB	20	80	120	260	320	3500	6.8 ±20%
PRG18BC4R7MM1RB	20	100	155	330	400	5000	4.7 ±20%
PRG18BC3R3MM1RB	16	120	180	400	480	4500	3.3 ±20%
PRG18BC2R2MM1RB	12	150	220	500	600	5000	2.2 ±20%
PRG18BC1R0MM1RB	6	220	330	740	850	7500	1.0 ±20%

Maximum Current shows typical capacities of the transformer which can be used.

This product is recognized by UL.

⚠️Note • This PDF catalog is downloaded from the website of Murata Manufacturing co., Ltd. Therefore, it's specifications are subject to change or our products in it may be discontinued without advance notice. Please check with our sales representatives or product engineers before ordering.
• This PDF catalog has only typical specifications because there is no space for detailed specifications. Therefore, please approve our product specifications or transact the approval sheet for product specifications before ordering.

PTC (POSISTOR®) for Circuit Protection

Chip Type 0805 (2012) Size

Part Number	Max. Voltage (V)	Hold Current (at +60°C) (mA)	Hold Current (at +25°C) (mA)	Trip Current (at +25°C) (mA)	Trip Current (at -10°C) (mA)	Max. Current (mA)	Resistance (at +25°C) (ohm)
PRG21BB220MB1RK	20	30	44	91	110	1100	22 ±20%
PRG21BB150MB1RK	20	40	59	116	140	1600	15 ±20%
PRG21BC6R8MM1RA	24	80	120	260	320	3500	6.8 ±20%
PRG21BC4R7MM1RA	24	100	155	330	400	5000	4.7 ±20%
PRG21BC3R3MM1RA	20	120	180	400	480	6000	3.3 ±20%
PRG21BC2R2MM1RA	16	150	220	500	600	6500	2.2 ±20%
PRG21BC1R0MM1RA	12	220	330	740	850	10000	1.0 ±20%
PRG21BC0R6MM1RA	6	285	420	920	1100	10000	0.6 ±20%
PRG21BC0R2MM1RA	6	500	750	1620	2000	10000	0.2 ±20%

Maximum Current shows typical capacities of the transformer which can be used.

This product is recognized by UL.

PTC (POSISTOR®) for Circuit Protection

Narrow Current Band 30V Series

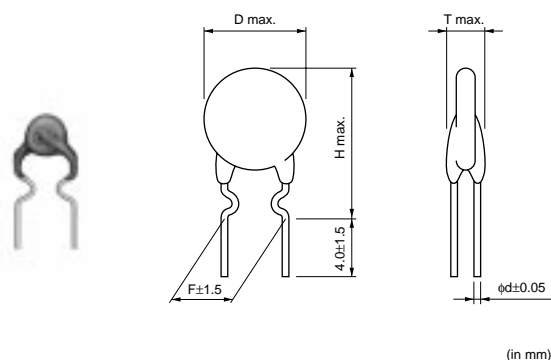

Part Number	Max. Voltage (V)	Hold Current (at +60°C) (mA)	Hold Current (at +25°C) (mA)	Trip Current (at +25°C) (mA)	Trip Current (at -10°C) (mA)	Max. Current (A)	Resistance (at +25°C) (ohm)	Body Diameter (D)(mm)	Thickness (T) (mm)	Height (H) (mm)	Lead Space (F)(mm)	Lead Diameter (phi d)(mm)
PTGL04AS100K2N51B0	30	122	154	205	240	1.5	10 ±10%	4.5	3.5	9.5	5.0	0.5
PTGL04AS100K2B51B0	30	167	212	282	330	2.0	10 ±10%	4.5	3.5	9.5	5.0	0.6
PTGL05AS3R9K2B51B0	30	269	340	452	530	3.5	3.9 ±10%	5.5	3.5	10.5	5.0	0.6
PTGL07AS2R7K2B51B0	30	336	425	565	663	4.5	2.7 ±10%	7.3	3.5	12.3	5.0	0.6
PTGL07AS1R8K2B51B0	30	420	532	708	829	5.0	1.8 ±10%	7.3	3.5	12.3	5.0	0.6
PTGL09AS1R2K2B51B0	30	556	704	936	1097	6.0	1.2 ±10%	9.3	3.5	14.3	5.0	0.6
PTGL12AS0R8K2B51B0	30	685	867	1153	1352	7.0	0.8 ±10%	11.5	3.5	16.5	5.0	0.6

Maximum Current shows typical capacities of the transformer which can be used.

30V Series is recognized by UL.

Taping type of part numbers with "A0" is available.

PTC (POSISTOR®) for Circuit Protection

Narrow Current Band 51/60V Series

Part Number	Max. Voltage (V)	Hold Current (at +60°C) (mA)	Hold Current (at +25°C) (mA)	Trip Current (at +25°C) (mA)	Trip Current (at -10°C) (mA)	Max. Current (A)	Resistance (at +25°C) (ohm)	Body Diameter (D)(mm)	Thickness (T) (mm)	Height (H) (mm)	Lead Space (F)(mm)	Lead Diameter (phi d)(mm)
PTGL04AS100K3B51B0	51	168	213	283	332	1.0	10 ±10%	4.5	3.5	9.5	5.0	0.6
PTGL05AS6R8K3B51B0	51	197	249	331	388	1.5	6.8 ±10%	5.5	3.5	10.5	5.0	0.6
PTGL07AS3R3K3B51B0	51	307	389	517	606	3.0	3.3 ±10%	7.3	3.5	12.3	5.0	0.6
PTGL09AS2R2K3B51B0	51	412	522	694	814	4.0	2.2 ±10%	9.3	3.5	14.3	5.0	0.6
PTGL12AS1R2K3B51B0	51	592	749	996	1168	5.0	1.2 ±10%	11.5	3.5	16.5	5.0	0.6
PTGL04AS220K4N51B0	60	88	112	149	175	1.0	22 ±10%	4.5	3.5	9.5	5.0	0.5
PTGL04AS220K4B51B0	60	115	145	193	226	1.0	22 ±10%	4.5	3.5	9.5	5.0	0.6
PTGL05AS100K4B51B0	60	170	215	286	335	1.5	10 ±10%	5.5	3.5	10.5	5.0	0.6
PTGL07AS5R6K4N51B0	60	186	236	314	368	2.2	5.6 ±10%	7.3	3.5	12.3	5.0	0.5
PTGL07AS5R6K4B51B0	60	229	290	386	452	3.0	5.6 ±10%	7.3	3.5	12.3	5.0	0.6
PTGL09AS3R3K4B51B0	60	333	421	560	656	4.0	3.3 ±10%	9.3	3.5	14.3	5.0	0.6
PTGL12AS2R2K4B51B0	60	439	556	739	867	5.0	2.2 ±10%	11.5	3.5	16.5	5.0	0.6

Maximum Current shows typical capacities of the transformer which can be used.
51/60V Series are recognized by UL.
Taping type of part numbers with "A0" is available.

PTC (POSISTOR®) for Circuit Protection

Narrow Current Band 140V Series

Part Number	Max. Voltage (V)	Hold Current (at +60°C) (mA)	Hold Current (at +25°C) (mA)	Trip Current (at +25°C) (mA)	Trip Current (at -10°C) (mA)	Max. Current (A)	Resistance (at +25°C) (ohm)	Body Diameter (D)(mm)	Thickness (T) (mm)	Height (H) (mm)	Lead Space (F)(mm)	Lead Diameter (phi d)(mm)
PTGL04AS560K6B51B0	140	74	94	125	147	0.5	56 ±10%	4.5	4.5	9.5	5.0	0.6
PTGL05AS270K6B51B0	140	106	134	178	209	1.0	27 ±10%	5.5	4.5	10.5	5.0	0.6
PTGL07AS150K6B51B0	140	148	187	249	292	1.5	15 ±10%	7.3	4.5	12.3	5.0	0.6
PTGL09AS120K6B51B0	140	192	244	324	380	2.0	12 ±10%	9.3	4.5	14.3	5.0	0.6
PTGL09AS7R6K6B51B0	140	227	287	382	447	2.2	7.6 ±10%	9.3	4.5	14.3	5.0	0.6
PTGL12AS4R7K6B51B0	140	310	393	523	613	3.5	4.7 ±10%	11.5	4.5	16.5	5.0	0.6

Maximum Current shows typical capacities of the transformer which can be used.
140V Series is recognized by UL.
Taping type of part numbers with "A0" is available.

PTC (POSISTOR®) for Circuit Protection

16V Series

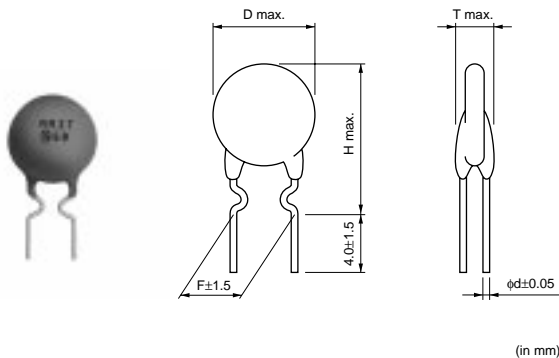

⚠️Note • This PDF catalog is downloaded from the website of Murata Manufacturing co., Ltd. Therefore, it's specifications are subject to change or our products in it may be discontinued without advance notice. Please check with our sales representatives or product engineers before ordering.
• This PDF catalog has only typical specifications because there is no space for detailed specifications. Therefore, please approve our product specifications or transact the approval sheet for product specifications before ordering.

Part Number	Max. Voltage (V)	Hold Current (at +60°C) (mA)	Hold Current (at +25°C) (mA)	Trip Current (at +25°C) (mA)	Trip Current (at -10°C) (mA)	Max. Current (A)	Resistance (at +25°C) (ohm)	Body Diameter (D)(mm)	Thickness (T) (mm)	Lead Space (F)(mm)	Lead Diameter (phi d)(mm)
PTGL05AR1R0M1B51B0	16	370	470	880	1040	2.0	1.0 ±20%	6.0	3.5	5.0	0.6
PTGL06AR0R8M1B51B0	16	400	505	955	1120	3.0	0.8 ±20%	6.5	3.5	5.0	0.6
PTGL07ARR47M1B51B0	16	560	705	1310	1570	5.0	0.47 ±20%	7.5	3.5	5.0	0.6
PTGL09ARR33M1B51B0	16	680	875	1625	1900	7.0	0.33 ±20%	9.0	3.5	5.0	0.6
PTGL10ARR27M1B51B0	16	800	1025	1900	2250	8.0	0.27 ±20%	10.1	3.5	5.0	0.6
PTGL12AR0R2M1B51B0	16	1000	1300	2410	2800	9.0	0.2 ±20%	11.3	3.5	5.0	0.6
PTGL14ARR15M1B51B0	16	1200	1545	2855	3360	10	0.15 ±20%	13.5	3.5	5.0	0.6

Maximum Current shows typical capacities of the transformer which can be used.
Taping type of part numbers with "A0" is available (except PTGL14ARR15M1B51B0).

PTC (POSISTOR®) for Circuit Protection

24/30/32V Series

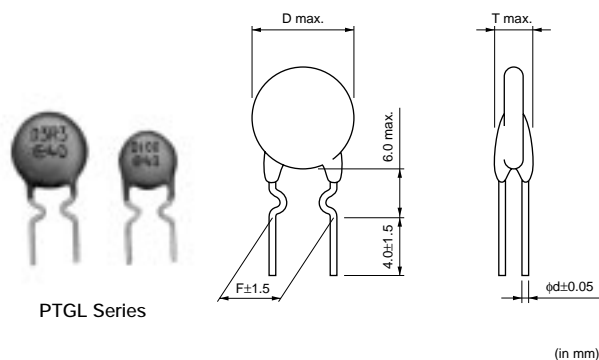

(in mm)

Part Number	Max. Voltage (V)	Hold Current (at +60°C) (mA)	Hold Current (at +25°C) (mA)	Trip Current (at +25°C) (mA)	Trip Current (at -10°C) (mA)	Max. Current (A)	Resistance (at +25°C) (ohm)	Body Diameter (D)(mm)	Thickness (T) (mm)	Lead Space (F)(mm)	Lead Diameter (phi d)(mm)
PTGL07BD100N2B51B0	24	80	124	251	320	2.0	10 ±30%	7.4	4.0	5.0	0.6
PTGL07BD6R8N2B51B0	24	90	139	296	370	2.0	6.8 ±30%	7.4	4.0	5.0	0.6
PTGL09BD4R7N2B51B0	24	120	216	398	500	2.0	4.7 ±30%	9.5	4.0	5.0	0.6
PTGL09BD3R3N2B51B0	24	140	248	461	580	2.0	3.3 ±30%	9.5	4.0	5.0	0.6
PTGL09BD2R2N2B51B0	24	180	326	431	710	2.0	2.2 ±30%	9.5	4.0	5.0	0.6
PTGL04AR130H2B51B0	30	145	180	350	400	0.7	13 ±25%	5.5	4.0	5.0	0.6
PTGL07AR4R6H2B51B0	30	250	340	610	700	2.0	4.6 ±25%	7.4	4.0	5.0	0.6
PTGL09AR1R8H2B51B0	30	410	510	970	1120	3.0	1.8 ±25%	9.5	4.0	5.0	0.6
PTGL12AR1R2H2B51B0	30	520	645	1225	1420	4.3	1.2 ±25%	12.0	4.0	5.0	0.6
PTGL13AR0R8H2B71B0	30	680	870	1600	1900	5.5	0.8 ±25%	13.5	4.0	7.5	0.6
PTGL07BD470N3B51B0	32	30	55	115	140	1.5	47 ±30%	7.4	4.0	5.0	0.6
PTGL07BD330N3B51B0	32	40	60	135	170	1.5	33 ±30%	7.4	4.0	5.0	0.6
PTGL07BD220N3B51B0	32	45	75	160	200	1.5	22 ±30%	7.4	4.0	5.0	0.6
PTGL07BD150N3B51B0	32	60	100	195	240	1.5	15 ±30%	7.4	4.0	5.0	0.6

Maximum Current shows typical capacities of the transformer which can be used.
24/30/32V Series are recognized by UL. (except PTGL13AR0R8H2B71B0)
Only PTGL_51B0 Series is available in taping type. Taping type of part numbers with "A0" is available.

△Note • This PDF catalog is downloaded from the website of Murata Manufacturing co., ltd. Therefore, it's specifications are subject to change or our products in it may be discontinued without advance notice. Please check with our sales representatives or product engineers before ordering.
• This PDF catalog has only typical specifications because there is no space for detailed specifications. Therefore, please approve our product specifications or transact the approval sheet for product specifications before ordering.

PTC (POSISTOR®) for Circuit Protection

56/80V Series

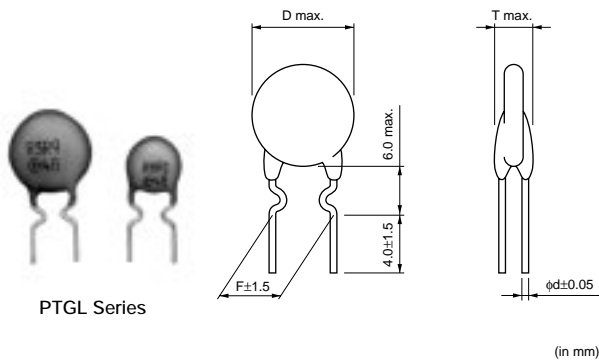

Part Number	Max. Voltage (V)	Hold Current (at +60°C) (mA)	Hold Current (at +25°C) (mA)	Trip Current (at +25°C) (mA)	Trip Current (at -10°C) (mA)	Max. Current (A)	Resistance (at +25°C) (ohm)	Body Diameter (D)(mm)	Thickness (T) (mm)	Lead Space (F)(mm)	Lead Diameter (phi d)(mm)
PTGL07AR220M3P51B0	56	90	115	205	240	1.0	22 ±20%	7.4	4.0	5.0	0.6
PTGL07AR8R2M3P51B0	56	130	165	300	350	1.0	8.2 ±20%	7.4	4.0	5.0	0.6
PTGL09AR150M3B51B0	56	150	190	340	400	1.2	15 ±20%	9.5	4.0	5.0	0.6
PTGL10AR3R9M3P51B0	56	210	260	470	550	2.0	3.9 ±20%	10.5	4.0	5.0	0.6
PTGL09AR4R7M3B51B0	56	270	350	600	700	2.0	4.7 ±20%	9.5	4.0	5.0	0.6
PTGL10AR3R9M3B51B0	56	300	390	680	800	2.0	3.9 ±20%	10.5	4.0	5.0	0.6
PTGL14AR3R3M3B71B0	56	380	490	830	980	2.5	3.3 ±20%	14.5	4.0	7.5	0.6
PTGL05AR550H4P51B0	80	50	62	115	135	0.7	55 ±25%	5.5	4.5	5.0	0.6
PTGL07AR250H4B51B0	80	110	140	260	300	1.0	25 ±25%	7.4	4.5	5.0	0.6
PTGL09AR9R4H4B51B0	80	190	240	450	530	3.0	9.4 ±25%	9.5	4.5	5.0	0.6
PTGL12AR5R6H4B71B0	80	270	350	650	760	4.3	5.6 ±25%	12.0	4.5	7.5	0.6
PTGL13AR3R7H4B71B0	80	310	405	750	860	5.5	3.7 ±25%	13.5	4.5	7.5	0.6

Maximum Current shows typical capacities of the transformer which can be used. Please contact us for UL recognized products.

Only PTGL_51B0 Series is available in taping type. Taping type of part numbers with "A0" is available.

PTC (POSISTOR®) for Circuit Protection

125/140V Series

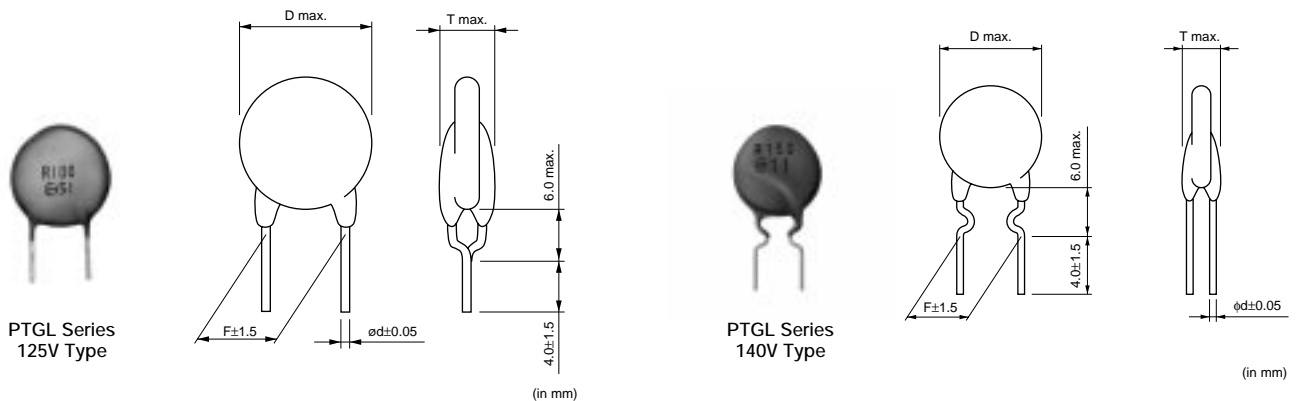

Part Number	Max. Voltage (V)	Hold Current (at +60°C) (mA)	Hold Current (at +25°C) (mA)	Trip Current (at +25°C) (mA)	Trip Current (at -10°C) (mA)	Max. Current (A)	Resistance (at +25°C) (ohm)	Body Diameter (D)(mm)	Thickness (T) (mm)	Lead Space (F)(mm)	Lead Diameter (phi d)(mm)
PTGL05AR181M7P52B0	125	30	38	64	75	0.3	180 ±20%	6.0	5.0	5.0	0.6
PTGL07AR750M7B52B0	125	65	82	142	165	0.3	75 ±20%	8.0	6.0	5.0	0.6
PTGL09AR470M6B52B0	125	90	120	200	230	0.5	47 ±20%	10.0	5.5	5.0	0.6
PTGL09AR220M6B52B0	125	135	175	290	340	0.8	22 ±20%	10.0	5.5	5.0	0.6

Continued on the following page.

Note • This PDF catalog is downloaded from the website of Murata Manufacturing co., Ltd. Therefore, it's specifications are subject to change or our products in it may be discontinued without advance notice. Please check with our sales representatives or product engineers before ordering.
• This PDF catalog has only typical specifications because there is no space for detailed specifications. Therefore, please approve our product specifications or transact the approval sheet for product specifications before ordering.

Continued from the preceding page.

Part Number	Max. Voltage (V)	Hold Current (at +60°C) (mA)	Hold Current (at +25°C) (mA)	Trip Current (at +25°C) (mA)	Trip Current (at -10°C) (mA)	Max. Current (A)	Resistance (at +25°C) (ohm)	Body Diameter (D)(mm)	Thickness (T) (mm)	Lead Space (F)(mm)	Lead Diameter (phi d)(mm)
PTGL12AR150M6B72B0	125	175	220	380	440	1.0	15 ±20%	12.5	5.5	7.5	0.6
PTGL14AR100M6B72B0	125	220	280	475	550	1.2	10 ±20%	15.0	5.5	7.5	0.6
PTGL18AR6R8M6B72B0	125	300	380	640	750	1.4	6.8 ±20%	18.5	5.5	7.5	0.6
PTGL18AR4R7M6B72B0	125	360	450	775	900	1.7	4.7 ±20%	18.5	5.5	7.5	0.6
PTGL18AR3R3M6B72B0	125	420	540	900	1050	2.0	3.3 ±20%	18.5	5.5	7.5	0.6
PTGL07AR330M6A51B0	140	100	130	200	230	0.5	33 ±20%	7.4	6.0	5.0	0.5
PTGL09AR220M6C61B0	140	140	180	280	330	1.0	22 ±20%	9.6	6.0	6.5	0.65
PTGL10AR150M6C61B0	140	170	220	345	400	1.0	15 ±20%	11.6	6.0	6.5	0.65
PTGL12AR100M6C01B0	140	220	290	440	510	1.0	10 ±20%	13.0	6.0	10.0	0.65
PTGL13AR6R8M6C01B0	140	290	370	575	670	1.0	6.8 ±20%	14.0	6.0	10.0	0.65
PTGL16AR5R6M6C01B0	140	340	440	670	780	2.0	5.6 ±20%	17.0	6.0	10.0	0.65

Maximum Current shows typical capacities of the transformer which can be used.

Please contact us for UL recognized products.

Only PTGL_52B0 Series is available in taping type. Taping type of part numbers with "A0" is available.

PTC (POSISTOR®) for Circuit Protection

250/265V Series

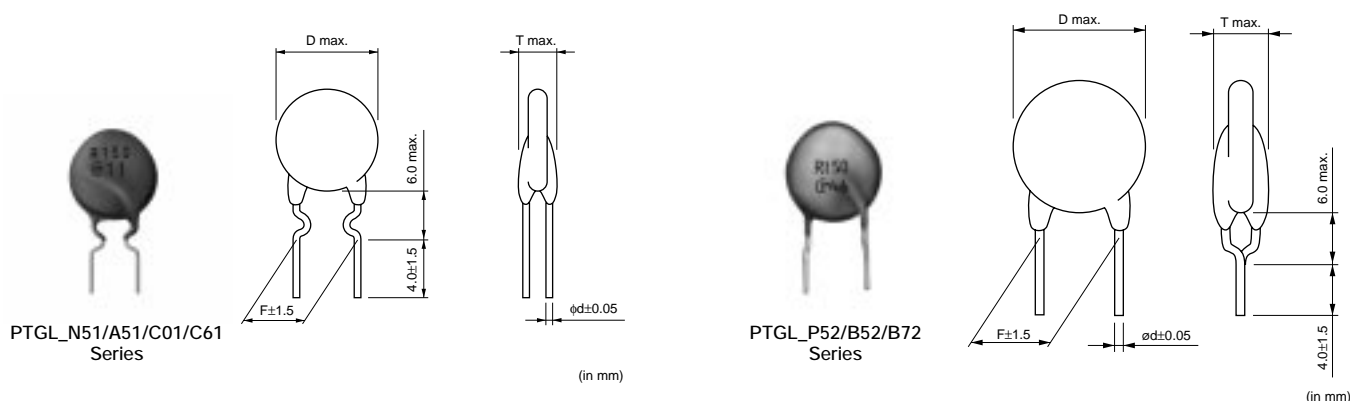

Part Number	Max. Voltage (V)	Hold Current (at +60°C) (mA)	Hold Current (at +25°C) (mA)	Trip Current (at +25°C) (mA)	Trip Current (at -10°C) (mA)	Max. Current (A)	Resistance (at +25°C) (ohm)	Body Diameter (D)(mm)	Thickness (T) (mm)	Lead Space (F)(mm)	Lead Diameter (phi d)(mm)
PTGL07BB220N0B52A0	250	90	130	250	300	0.5	22 ±30%	8.0	6.0	5.0	0.6
PTGL10BB120N0P52A0	250	90	130	250	300	0.6	12 ±30%	11.0	6.0	5.0	0.6
PTGL09AR390N0B52A0	250	100	115	245	280	0.6	39 ±30%	10.0	6.0	5.0	0.6
PTGL05AR151H8P52B0	265	28	35	65	78	0.2	150 ±25%	6.0	6.0	5.0	0.6
PTGL05AR181M9N51B0	265	29	37	60	70	0.3	180 ±20%	6.5	6.5	5.0	0.5
PTGL05AR121M9N51B0	265	35	47	75	85	0.3	120 ±20%	6.5	6.5	5.0	0.5
PTGL07AR820M9A51B0	265	60	75	125	150	0.5	82 ±20%	8.2	6.5	5.0	0.5
PTGL07AR700H8B52B0	265	66	85	160	185	0.4	70 ±25%	8.0	6.0	5.0	0.6
PTGL07AR650H8B52B0	265	68	84	162	190	1.0	65 ±25%	8.0	6.0	5.0	0.6
PTGL07AR450H8B52B0	265	80	105	200	220	1.0	45 ±25%	8.0	6.0	5.0	0.6
PTGL07AR560M9A51B0	265	80	95	165	190	0.8	56 ±20%	8.2	6.5	5.0	0.5
PTGL09AR390M9C61B0	265	100	130	210	240	1.2	39 ±20%	10.0	6.5	6.5	0.65
PTGL09AR250H8B52B0	265	118	150	290	330	1.0	25 ±25%	10.0	6.0	5.0	0.6
PTGL12AR270M9C01B0	265	150	200	310	360	1.5	27 ±20%	14.0	6.5	10.0	0.65
PTGL12AR150H8B72B0	265	165	210	400	460	1.5	15 ±25%	12.5	6.0	7.5	0.6
PTGL14AR180M9C01B0	265	180	230	380	440	1.8	18 ±20%	15.7	6.5	10.0	0.65
PTGL13AR100H8B72B0	265	200	260	480	560	2.2	10 ±25%	14.0	6.0	7.5	0.6
PTGL18AR6R0H8B72B0	265	300	380	715	830	4.1	6.0 ±25%	18.5	6.0	7.5	0.6

Maximum Current shows typical capacities of the transformer which can be used.

250V/265V Series are recognized by UL.

Only PTGL_52B0 Series are available in taping type. Taping type of part numbers with "A0" is available.

△Note • This PDF catalog is downloaded from the website of Murata Manufacturing co., ltd. Therefore, it's specifications are subject to change or our products in it may be discontinued without advance notice. Please check with our sales representatives or product engineers before ordering.
• This PDF catalog has only typical specifications because there is no space for detailed specifications. Therefore, please approve our product specifications or transact the approval sheet for product specifications before ordering.

PTC (POSISTOR®) for Overheat Sensing

Chip Type 0402 (1005) Size

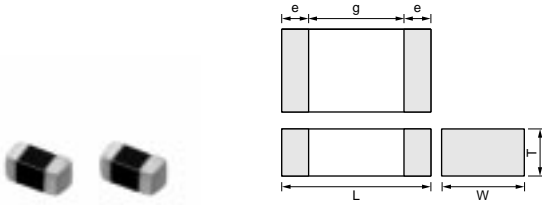

Part Number	Dimensions (mm)				
	L	W	T	e	g
PRF15_RC	1.0±0.05	0.5±0.05	0.5±0.05	0.15 to 0.4	0.3 min.
PRF18_RB	1.6±0.15	0.8±0.15	0.8±0.15	0.1 to 0.6	-
PRF21_RA	2.0±0.2	1.25±0.2	0.9±0.2	0.2 min.	0.5 min.

Part Number	Sensing Temperature (at 4.7k ohm) (°C)	Maximum Voltage (V)	Resistance (25°C) (ohm)	Operating Temperature Range (°C)
PRF15BC471QB1RC	105 ±5°C	32	470 ±50%	-20 to 120
PRF15BB471QB1RC	115 ±5°C	32	470 ±50%	-20 to 130
PRF15BA471QB1RC	125 ±5°C	32	470 ±50%	-20 to 140

This product is applied to reflow soldering.
This product is recognized by UL.

PTC (POSISTOR®) for Overheat Sensing

Chip Type 0603 (1608) Size

Part Number	Sensing Temperature (at 4.7k ohm) (°C)	Sensing Temperature (at 47k ohm) (°C)	Maximum Voltage (V)	Resistance (25°C) (ohm)	Operating Temperature Range (°C)
PRF18BG471QB5RB	65 ±5°C	80 ±7°C	32	470 ±50%	-20 to 90
PRF18BF471QB5RB	75 ±5°C	90 ±7°C	32	470 ±50%	-20 to 100
PRF18BE471QB5RB	85 ±5°C	100 ±7°C	32	470 ±50%	-20 to 110
PRF18BD471QB5RB	95 ±5°C	110 ±7°C	32	470 ±50%	-20 to 120
PRF18BC471QB5RB	105 ±5°C	120 ±7°C	32	470 ±50%	-20 to 130
PRF18BB471QB5RB	115 ±5°C	130 ±7°C	32	470 ±50%	-20 to 140
PRF18BA471QB5RB	125 ±5°C	140 ±7°C	32	470 ±50%	-20 to 150
PRF18AR471QB5RB	135 ±5°C	150 ±7°C	32	470 ±50%	-20 to 160
PRF18AS471QB5RB	145 ±5°C	-	32	470 ±50%	-20 to 160

This product is applied to flow/reflow soldering.
This product is recognized by UL.

PTC (POSISTOR®) for Overheat Sensing

Chip Type 0805 (2012) Size

Part Number	Sensing Temperature (at 4.7k ohm) (°C)	Maximum Voltage (V)	Resistance (25°C) (ohm)	Operating Temperature Range (°C)
PRF21BE471QB5RA	85 ±5°C	32	470 ±50%	-20 to 100
PRF21BD471QB5RA	95 ±5°C	32	470 ±50%	-20 to 110
PRF21BC471QB5RA	105 ±5°C	32	470 ±50%	-20 to 120
PRF21BB471QB5RA	115 ±5°C	32	470 ±50%	-20 to 130
PRF21BA471QB5RA	125 ±5°C	32	470 ±50%	-20 to 140
PRF21AR471QB5RA	135 ±5°C	32	470 ±50%	-20 to 150
PRF21AS471QB5RA	145 ±5°C	32	470 ±50%	-20 to 160

This product is applied to flow/reflow soldering.
This product is recognized by UL.

Note • This PDF catalog is downloaded from the website of Murata Manufacturing co., Ltd. Therefore, it's specifications are subject to change or our products in it may be discontinued without advance notice. Please check with our sales representatives or product engineers before ordering.
• This PDF catalog has only typical specifications because there is no space for detailed specifications. Therefore, please approve our product specifications or transact the approval sheet for product specifications before ordering.

PTC (POSISTOR®) for Overheat Sensing

Chip Tight Tolerance Type 0402(1005) Size

Part Number	Sensing Temperature (at 4.7M ohm) (°C)	Maximum Voltage (V)	Resistance (25°C) (k ohm)	Operating Temperature Range (°C)
PRF15BE103RB6RC	100 ±3°C	32	10 ±50%	-20 to 110
PRF15BG103RB6RC	80 ±3°C	32	10 ±50%	-20 to 90

This product is applied to reflow soldering.

PTC (POSISTOR®) for Overheat Sensing

Chip Tight Tolerance Type 0603 (1608)Size

Part Number	Sensing Temperature (at 4.7k ohm) (°C)	Maximum Voltage (V)	Resistance (25°C) (ohm)	Operating Temperature Range (°C)
PRF18BG471RB5RB	65 ±3°C	32	470 ±50%	-20 to 80
PRF18BF471RB5RB	75 ±3°C	32	470 ±50%	-20 to 90
PRF18BE471RB5RB	85 ±3°C	32	470 ±50%	-20 to 100
PRF18BD471RB5RB	95 ±3°C	32	470 ±50%	-20 to 110
PRF18BC471RB5RB	105 ±3°C	32	470 ±50%	-20 to 120
PRF18BB471RB5RB	115 ±3°C	32	470 ±50%	-20 to 130

This product is applied to flow/reflow soldering.

This product is recognized by UL.

PTC (POSISTOR®) for Overheat Sensing

Lead Type

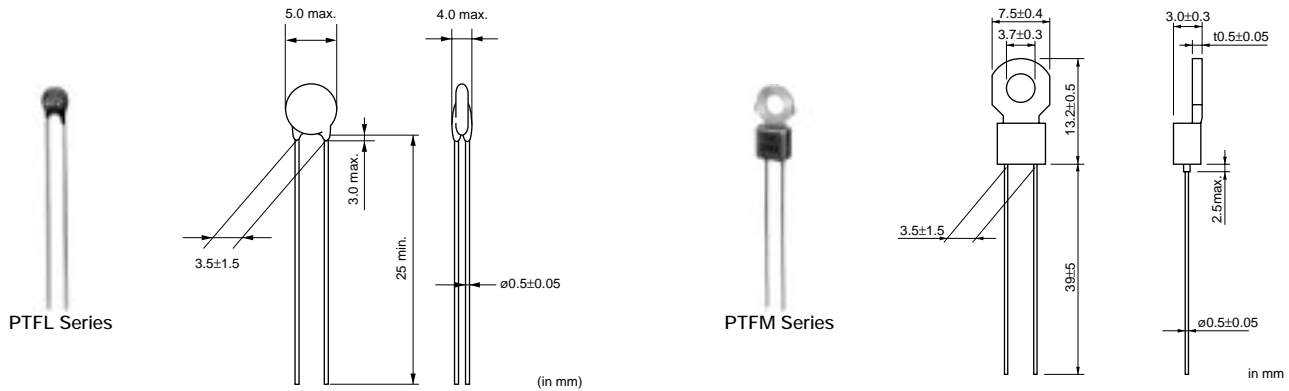

Part Number	Max. Voltage (V)	Sensing Temp. (TS) (°C)	Resistance Value at 25°C (max.) (ohm)	Resistance Value (TS -10°C) (max.) (ohm)	Resistance Value (TS°C) (min.) (ohm)
PTF□04BH471Q2N34B0	16	60	100	330	470
PTF□04BG471Q2N34B0	16	70	100	330	470
PTF□04BF471Q2N34B0	16	80	100	330	470
PTF□04BE471Q2N34B0	16	90	100	330	470
PTF□04BD471Q2N34B0	16	100	100	330	470
PTF□04BC471Q2N34B0	16	110	100	330	470
PTF□04BB471Q2N34B0	16	120	100	330	470
PTF□04BH222Q2N34B0	16	60	330	1.5k	2.2k
PTF□04BG222Q2N34B0	16	70	330	1.5k	2.2k
PTF□04BF222Q2N34B0	16	80	330	1.5k	2.2k
PTF□04BE222Q2N34B0	16	90	330	1.5k	2.2k
PTF□04BD222Q2N34B0	16	100	330	1.5k	2.2k
PTF□04BC222Q2N34B0	16	110	330	1.5k	2.2k

Continued on the following page. ↗

△Note • This PDF catalog is downloaded from the website of Murata Manufacturing co., ltd. Therefore, it's specifications are subject to change or our products in it may be discontinued without advance notice. Please check with our sales representatives or product engineers before ordering.
• This PDF catalog has only typical specifications because there is no space for detailed specifications. Therefore, please approve our product specifications or transact the approval sheet for product specifications before ordering.

● Plug in Type PTH8M Series

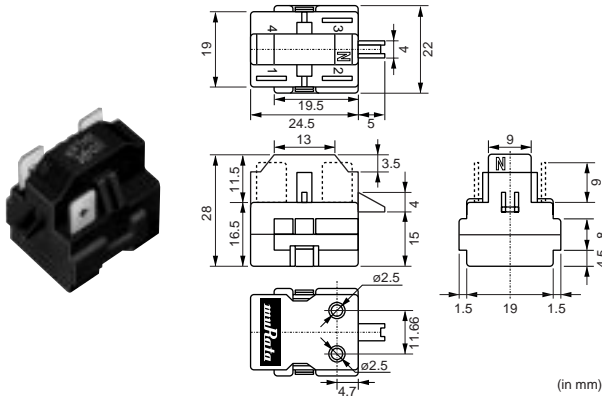

Part Number	Resistance Value (at 25°C) (ohm)	Max. Volt. (V)	Max. Current (A)	Operating Time Char. (25°C) (s)	Starting System
PTH8M4R7MB3-00	4.7 ±20%	180	12	1.5 to 3.5(150V,25ohm)	CSR
PTH8M4R7MC1-00	4.7 ±20%	180	12	1.5 to 3.5(150V,25ohm)	RSIR
PTH8M4R7MC2-00	4.7 ±20%	180	12	1.5 to 3.5(150V,25ohm)	RSIR
PTH8M4R7MD2-00	4.7 ±20%	180	12	1.5 to 3.5(150V,25ohm)	RSCR
PTH8M4R7MD3-00	4.7 ±20%	180	12	1.5 to 3.5(150V,25ohm)	RSCR
PTH8M6R8MB3-00	6.8 ±20%	200	10	1.1 to 2.7(150V,25ohm)	CSR
PTH8M6R8MC1-00	6.8 ±20%	200	10	1.1 to 2.7(150V,25ohm)	RSIR
PTH8M6R8MC2-00	6.8 ±20%	200	10	1.1 to 2.7(150V,25ohm)	RSIR
PTH8M6R8MD2-00	6.8 ±20%	200	10	1.1 to 2.7(150V,25ohm)	RSCR
PTH8M6R8MD3-00	6.8 ±20%	200	10	1.1 to 2.7(150V,25ohm)	RSCR
PTH8M100MB3-00	10 ±20%	225	9	0.6 to 2.1(150V,25ohm)	CSR
PTH8M100MC1-00	10 ±20%	225	9	0.6 to 2.1(150V,25ohm)	RSIR
PTH8M100MC2-00	10 ±20%	225	9	0.6 to 2.1(150V,25ohm)	RSIR
PTH8M100MD2-00	10 ±20%	225	9	0.6 to 2.1(150V,25ohm)	RSCR
PTH8M100MD3-00	10 ±20%	225	9	0.6 to 2.1(150V,25ohm)	RSCR
PTH8M330MB3-00	33 ±20%	355	6	0.45 to 1.35(280V,55ohm)	CSR
PTH8M330MC1-00	33 ±20%	355	6	0.45 to 1.35(280V,55ohm)	RSIR
PTH8M330MC2-00	33 ±20%	355	6	0.45 to 1.35(280V,55ohm)	RSIR
PTH8M330MD2-00	33 ±20%	355	6	0.45 to 1.35(280V,55ohm)	RSCR
PTH8M330MD3-00	33 ±20%	355	6	0.45 to 1.35(280V,55ohm)	RSCR

Please contact us when you need UL and VDE approved models other than the above mentioned types.

NTC for Temp. Sensor and Compensation

Chip Type 0201 (0603) Size

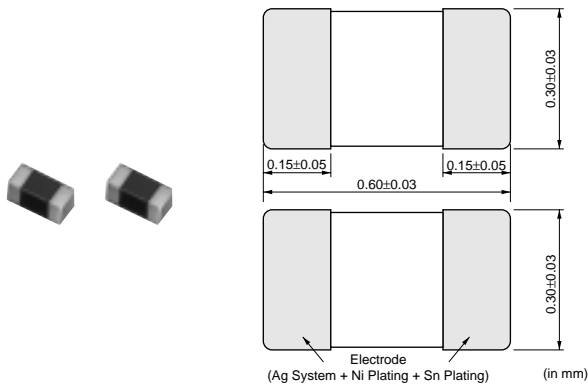

△Note • This PDF catalog is downloaded from the website of Murata Manufacturing co., ltd. Therefore, it's specifications are subject to change or our products in it may be discontinued without advance notice. Please check with our sales representatives or product engineers before ordering.
• This PDF catalog has only typical specifications because there is no space for detailed specifications. Therefore, please approve our product specifications or transact the approval sheet for product specifications before ordering.

Part Number	Resistance (25°C) (ohm)	B-Constant (25-50°C) (K)	B-Constant (25-80°C) (Reference Value) (K)	B-Constant (25-85°C) (Reference Value) (K)	B-Constant (25-100°C) (Reference Value) (K)	Permissible Operating Current(25°C) (mA)	Rated Electric Power (25°C) (mW)	Typical Dissipation Constant (25°C) (mW/°C)
NCP03YS110J05RL	11 ±5%	2750 ±3%	2758	2758	2758	9.50	100	1
NCP03YS220J05RL	22 ±5%	2750 ±3%	2758	2758	2758	6.70	100	1
NCP03YS330J05RL	33 ±5%	2750 ±3%	2758	2758	2758	5.50	100	1
NCP03YS470J05RL	47 ±5%	2750 ±3%	2758	2758	2758	4.60	100	1
NCP03YS680J05RL	68 ±5%	2750 ±3%	2758	2758	2758	3.80	100	1
NCP03YS101J05RL	100 ±5%	2750 ±3%	2758	2758	2758	3.10	100	1
NCP03XM102□05RL	1.0k	3500 ±1%	3539	3545	3560	1.00	100	1
NCP03XM152□05RL	1.5k	3500 ±1%	3539	3545	3560	0.81	100	1
NCP03XM222□05RL	2.2k	3500 ±1%	3539	3545	3560	0.67	100	1
NCP03XM332□05RL	3.3k	3500 ±1%	3539	3545	3560	0.55	100	1
NCP03XM472□05RL	4.7k	3500 ±1%	3539	3545	3560	0.46	100	1
NCP03XH682□05RL	6.8k	3380 ±1%	3428	3434	3455	0.38	100	1
NCP03XH103F05RL	10k ±1%	3380 ±1%	3428	3434	3455	0.31	100	1
NCP03XH103□05RL	10k	3380 ±1%	3428	3434	3455	0.31	100	1
NCP03XV103□05RL	10k	3900 ±1%	3930	3934	3944	0.31	100	1
NCP03XH153□05RL	15k	3380 ±1%	3428	3434	3455	0.25	100	1
NCP03XH223□05RL	22k	3380 ±1%	3428	3434	3455	0.21	100	1
NCP03WF333□05RL	33k	4250 ±1%	4303	4311	4334	0.17	100	1
NCP03WB473□05RL	47k	4050 ±3%	4101	4108	4131	0.14	100	1
NCP03WL473□05RL	47k	4485 ±1%	4537	4543	4557	0.14	100	1
NCP03WF683□05RL	68k	4250 ±1%	4303	4311	4334	0.12	100	1
NCP03WL683□05RL	68k	4485 ±1%	4537	4543	4557	0.12	100	1
NCP03WF104F05RL	100k ±1%	4250 ±1%	4303	4311	4334	0.10	100	1
NCP03WF104□05RL	100k	4250 ±1%	4303	4311	4334	0.10	100	1
NCP03WL104□05RL	100k	4485 ±1%	4537	4543	4557	0.10	100	1
NCP03WL154□05RL	150k	4485 ±1%	4537	4543	4557	0.08	100	1
NCP03WL224□05RL	220k	4485 ±1%	4537	4543	4557	0.06	100	1

Reflow soldering methods can be employed.
 A blank column is filled with resistance tolerance codes (E: ±3%, J: ±5%).
 Operating temperature range is -40 to +125°C.
 Please contact us for UL/cUL recognized products.

NTC for Temp. Sensor and Compensation

Chip Type 0402 (1005) Size

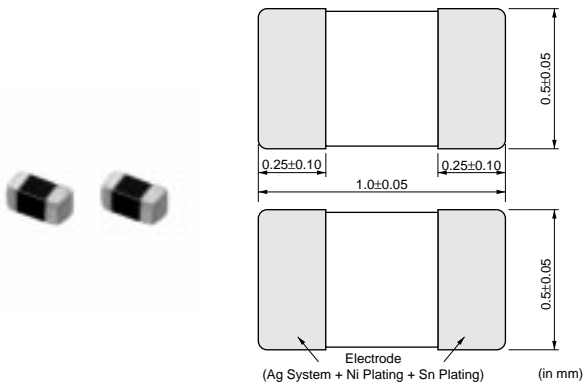

Part Number	Resistance (25°C) (ohm)	B-Constant (25-50°C) (K)	B-Constant (25-80°C) (Reference Value) (K)	B-Constant (25-85°C) (Reference Value) (K)	B-Constant (25-100°C) (Reference Value) (K)	Permissible Operating Current(25°C) (mA)	Rated Electric Power (25°C) (mW)	Typical Dissipation Constant (25°C) (mW/°C)
NCP15XC220□03RC	22	3100 ±3%	3126	3128	3136	6.70	100	1
NCP15XC330□03RC	33	3100 ±3%	3126	3128	3136	5.50	100	1
NCP15XC470□03RC	47	3100 ±3%	3126	3128	3136	4.60	100	1

Continued on the following page.

⚠️Note • This PDF catalog is downloaded from the website of Murata Manufacturing co., Ltd. Therefore, it's specifications are subject to change or our products in it may be discontinued without advance notice. Please check with our sales representatives or product engineers before ordering.
 • This PDF catalog has only typical specifications because there is no space for detailed specifications. Therefore, please approve our product specifications or transact the approval sheet for product specifications before ordering.

Continued from the preceding page.

Part Number	Resistance (25°C) (ohm)	B-Constant (25-50°C) (K)	B-Constant (25-80°C) (Reference Value) (K)	B-Constant (25-85°C) (Reference Value) (K)	B-Constant (25-100°C) (Reference Value) (K)	Permissible Operating Current(25°C) (mA)	Rated Electric Power (25°C) (mW)	Typical Dissipation Constant (25°C) (mW/°C)
NCP15XC680□03RC	68	3100 ±3%	3126	3128	3136	3.80	100	1
NCP15XF101□03RC	100	3250 ±3%	3282	3284	3296	3.10	100	1
NCP15XF151□03RC	150	3250 ±3%	3282	3284	3296	2.50	100	1
NCP15XM221□03RC	220	3500 ±3%	3539	3545	3560	2.10	100	1
NCP15XM331□03RC	330	3500 ±3%	3539	3545	3560	1.70	100	1
NCP15XQ471□03RC	470	3650 ±2%	3688	3693	3706	1.40	100	1
NCP15XQ681□03RC	680	3650 ±3%	3688	3693	3706	1.20	100	1
NCP15XQ102□03RC	1.0k	3650 ±2%	3688	3693	3706	1.00	100	1
NCP15XW152□03RC	1.5k	3950 ±3%	3982	3987	3998	0.81	100	1
NCP15XW222□03RC	2.2k	3950 ±3%	3982	3987	3998	0.67	100	1
NCP15XW332□03RC	3.3k	3950 ±3%	3982	3987	3998	0.55	100	1
NCP15XM472□03RC	4.7k	3500 ±2%	3539	3545	3560	0.46	100	1
NCP15XW682□03RC	6.8k	3950 ±3%	3982	3987	3998	0.38	100	1
NCP15XH103D03RC	10k ±0.5%	3380 ±0.7%	3428	3434	3455	0.31	100	1
NCP15XH103F03RC	10k ±1%	3380 ±1%	3428	3434	3455	0.31	100	1
NCP15XH103□03RC	10k	3380 ±1%	3428	3434	3455	0.31	100	1
NCP15XV103□03RC	10k	3900 ±3%	3930	3934	3944	0.31	100	1
NCP15XW153□03RC	15k	3950 ±3%	3982	3987	3998	0.25	100	1
NCP15XW223□03RC	22k	3950 ±3%	3982	3987	3998	0.21	100	1
NCP15WL223□03RC	22k	4485 ±1%	4537	4543	4557	0.21	100	1
NCP15WB333□03RC	33k	4050 ±3%	4101	4108	4131	0.17	100	1
NCP15WL333□03RC	33k	4485 ±1%	4537	4543	4557	0.17	100	1
NCP15WB473F03RC	47k ±1%	4050 ±1%	4101	4108	4131	0.14	100	1
NCP15WB473□03RC	47k	4050 ±1%	4101	4108	4131	0.14	100	1
NCP15WL473□03RC	47k	4485 ±1%	4537	4543	4557	0.14	100	1
NCP15WD683□03RC	68k	4150 ±3%	4201	4209	4232	0.12	100	1
NCP15WL683□03RC	68k	4485 ±1%	4537	4543	4557	0.12	100	1
NCP15WF104F03RC	100k ±1%	4250 ±1%	4303	4311	4334	0.10	100	1
NCP15WF104□03RC	100k	4250 ±1%	4303	4311	4334	0.10	100	1
NCP15WL104□03RC	100k	4485 ±1%	4537	4543	4557	0.10	100	1
NCP15WL154□03RC	150k	4485 ±1%	4537	4543	4557	0.08	100	1
NCP15WM154□03RC	150k	4500 ±3%	4571	4582	4614	0.08	100	1
NCP15WM224□03RC	220k	4500 ±3%	4571	4582	4614	0.06	100	1
NCP15WM474□03RC	470k	4500 ±3%	4571	4582	4614	0.04	100	1

Reflow soldering methods can be employed.

A blank column is filled with resistance tolerance codes (E: ±3%, J: ±5%).

Operating temperature range is -40 to +125°C.

Please contact us for UL/cUL recognized products.

△Note • This PDF catalog is downloaded from the website of Murata Manufacturing co., ltd. Therefore, it's specifications are subject to change or our products in it may be discontinued without advance notice. Please check with our sales representatives or product engineers before ordering.
• This PDF catalog has only typical specifications because there is no space for detailed specifications. Therefore, please approve our product specifications or transact the approval sheet for product specifications before ordering.

NTC for Temp. Sensor and Compensation

Chip Type 0603 (1608) Size

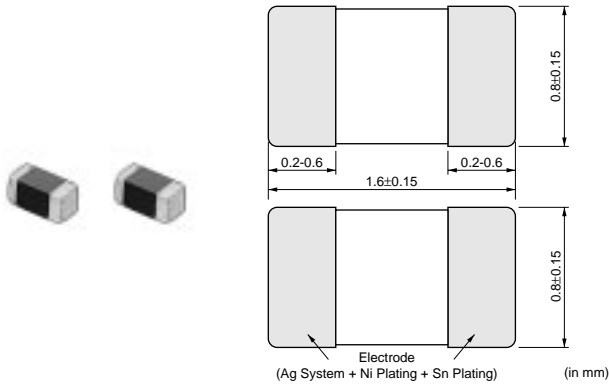

Part Number	Resistance (25°C) (ohm)	B-Constant (25-50°C) (K)	B-Constant (25-80°C) (Reference Value) (K)	B-Constant (25-85°C) (Reference Value) (K)	B-Constant (25-100°C) (Reference Value) (K)	Permissible Operating Current(25°C) (mA)	Rated Electric Power (25°C) (mW)	Typical Dissipation Constant (25°C) (mW/°C)
NCP18XF101□03RB	100	3250 ±3%	3282	3284	3296	3.10	100	1
NCP18XF151□03RB	150	3250 ±3%	3282	3284	3296	2.50	100	1
NCP18XM221□03RB	220	3500 ±3%	3539	3545	3560	2.10	100	1
NCP18XM331□03RB	330	3500 ±3%	3539	3545	3560	1.70	100	1
NCP18XQ471□03RB	470	3650 ±2%	3688	3693	3706	1.40	100	1
NCP18XQ681□03RB	680	3650 ±3%	3688	3693	3706	1.20	100	1
NCP18XQ102□03RB	1.0k	3650 ±2%	3688	3693	3706	1.00	100	1
NCP18XW152□03RB	1.5k	3950 ±3%	3982	3987	3998	0.81	100	1
NCP18XW222□03RB	2.2k	3950 ±3%	3982	3987	3998	0.67	100	1
NCP18XW332□03RB	3.3k	3950 ±3%	3982	3987	3998	0.55	100	1
NCP18XM472□03RB	4.7k	3500 ±2%	3539	3545	3560	0.46	100	1
NCP18XW682□03RB	6.8k	3950 ±3%	3982	3987	3998	0.38	100	1
NCP18XH103D03RB	10k ±0.5%	3380 ±0.7%	3428	3434	3455	0.31	100	1
NCP18XH103F03RB	10k ±1%	3380 ±1%	3428	3434	3455	0.31	100	1
NCP18XH103□03RB	10k	3380 ±1%	3428	3434	3455	0.31	100	1
NCP18XV103□03RB	10k	3900 ±3%	3930	3934	3944	0.31	100	1
NCP18XW153□03RB	15k	3950 ±3%	3982	3987	3998	0.25	100	1
NCP18XW223□03RB	22k	3950 ±3%	3982	3987	3998	0.21	100	1
NCP18WB333□03RB	33k	4050 ±3%	4101	4108	4131	0.17	100	1
NCP18WB473F10RB	47k ±1%	4050 ±1.5%	4101	4108	4131	0.14	100	1
NCP18WB473□03RB	47k	4050 ±2%	4101	4108	4131	0.14	100	1
NCP18WD683□03RB	68k	4150 ±3%	4201	4209	4232	0.12	100	1
NCP18WF104F12RB	100k ±1%	4200 ±1%	4255	4260	4282	0.10	100	1
NCP18WF104□03RB	100k	4250 ±2%	4255	4260	4282	0.10	100	1
NCP18WM154□03RB	150k	4500 ±3%	4571	4582	4614	0.08	100	1
NCP18WM224□03RB	220k	4500 ±3%	4571	4582	4614	0.06	100	1
NCP18WM474□03RB	470k	4500 ±3%	4571	4582	4614	0.04	100	1

Both flow and reflow soldering methods can be employed.

A blank column is filled with resistance tolerance codes (E: ±3%, J: ±5%).

Operating temperature range is -40 to +125°C.

This series is recognized by UL/cUL.

NTC for Temp. Sensor and Compensation

Chip Type 0805 (2012) Size

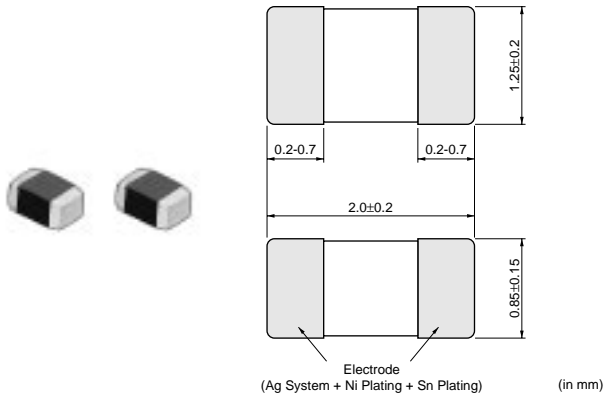

Part Number	Resistance (25°C) (ohm)	B-Constant (25-50°C) (K)	B-Constant (25-80°C) (Reference Value) (K)	B-Constant (25-85°C) (Reference Value) (K)	B-Constant (25-100°C) (Reference Value) (K)	Permissive Operating Current(25°C) (mA)	Rated Electric Power (25°C) (mW)	Typical Dissipation Constant (25°C) (mW/°C)
NCP21XM221J03RA	220 ±5%	3500 ±3%	3539	3545	3560	3.00	200	2
NCP21XQ471J03RA	470 ±5%	3650 ±3%	3688	3693	3706	2.00	200	2
NCP21XQ102J03RA	1.0k ±5%	3650 ±3%	3688	3693	3706	1.40	200	2
NCP21XW222J03RA	2.2k ±5%	3950 ±3%	3982	3987	3998	0.90	200	2
NCP21XM472J03RA	4.7k ±5%	3500 ±3%	3539	3545	3560	0.65	200	2
NCP21XV103J03RA	10k ±5%	3900 ±3%	3930	3934	3944	0.44	200	2
NCP21XW153J03RA	15k ±5%	3950 ±3%	3982	3987	3998	0.36	200	2
NCP21XW223J03RA	22k ±5%	3950 ±3%	3982	3987	3998	0.30	200	2
NCP21WB333J03RA	33k ±5%	4050 ±3%	4101	4108	4131	0.24	200	2
NCP21WB473J03RA	47k ±5%	4050 ±3%	4101	4108	4131	0.20	200	2
NCP21WF104J03RA	100k ±5%	4250 ±3%	4303	4311	4334	0.14	200	2

Both flow and reflow soldering methods can be employed.

Operating temperature range is -40 to +125°C.

This series is recognized by UL/cUL.

NTC for Inrush Current Suppression

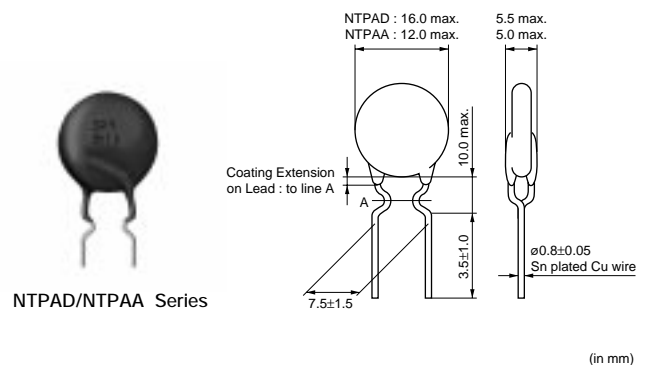
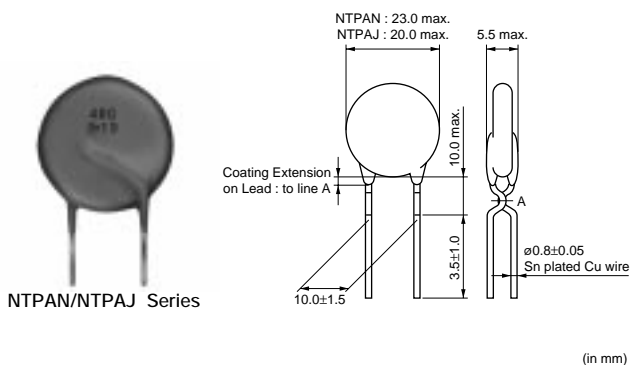

(in mm)

(in mm)

Continued on the following page.

Note • This PDF catalog is downloaded from the website of Murata Manufacturing co., ltd. Therefore, it's specifications are subject to change or our products in it may be discontinued without advance notice. Please check with our sales representatives or product engineers before ordering.
• This PDF catalog has only typical specifications because there is no space for detailed specifications. Therefore, please approve our product specifications or transact the approval sheet for product specifications before ordering.

Continued from the preceding page.



NTPA9/NTPA7 Series

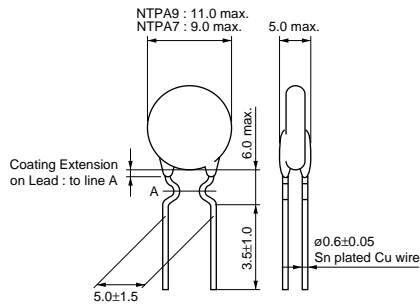

(in mm)

Part Number	Resistance (25°C) (ohm)	Permissible Max. Current (25°C) (A)	Permissible Max. Current (55°C) (A)	Thermal Time Constant (25°C) (s)	Thermal Dissipation Constant (25°C) (mW/°C)	Permissible Electrolytic Capacitor (μF)
NTPAN3R0LDKB0	3.0 ±15%	5.4	4.7	135	26.8	8600 at 100V
NTPAN4R0LDKB0	4.0 ±15%	4.7	4.1	130	26.8	8600 at 100V
NTPAN6R0LDKB0	6.0 ±15%	3.9	3.4	130	26.8	8600 at 100V
NTPAJ4R0LDKB0	4.0 ±15%	4.0	3.5	125	21.8	5000 at 100V
NTPAJ6R0LDKB0	6.0 ±15%	3.4	2.9	125	21.8	5000 at 100V
NTPAJ8R0LDKB0	8.0 ±15%	3.0	2.6	130	21.8	5000 at 100V
NTPAJ100LDKB0	10.0 ±15%	2.6	2.2	130	21.8	5000 at 100V
NTPAD3R9LDNB0	3.9 ±15%	3.3	2.9	65	18.2	2700 at 100V
NTPAD5R1LDNB0	5.1 ±15%	3.0	2.6	85	18.8	2700 at 100V
NTPAD8R0LDNB0	8.0 ±15%	2.7	2.3	65	18.7	2700 at 100V
NTPAD160LDNB0	16.0 ±15%	2.0	1.7	100	19.1	2700 at 100V
NTPAA2R2LDNB0	2.2 ±15%	3.7	3.2	70	13.5	1400 at 100V
NTPAA3R9LDNB0	3.9 ±15%	2.7	2.3	70	13.5	1400 at 100V
NTPAA5R1LDNB0	5.1 ±15%	2.5	2.2	70	13.5	1400 at 100V
NTPAA8R2LDNB0	8.2 ±15%	2.0	1.7	70	13.5	1400 at 100V
NTPAA100LDNB0	10.0 ±15%	1.7	1.5	70	13.5	1400 at 100V
NTPA9160LBMB0	16.0 ±15%	1.4	1.2	65	11.6	800 at 100V
NTPA74R0LBMB0	4.0 ±15%	2.3	2.0	40	9.4	700 at 100V
NTPA78R0LBMB0	8.0 ±15%	1.7	1.5	40	9.5	570 at 100V
NTPA7160LBMB0	16.0 ±15%	1.2	1.0	40	9.9	400 at 100V
NTPA7220LBMB0	22.0 ±15%	1.0	0.88	40	9.1	400 at 100V

NTPAD/NTPAA/NTPA9/NTPA7 series are also available on tape. The final alphabet of the part number should be "DNB0=>D6A0", "BMB0=>B1A0".
Operating temperature range is -20 to +160°C.

11

Power Supplies

Switching Power Supplies

Ultra Low Profile Switching Power Supplies

DC-DC Converters

Ionizer Modules (Ionissimo™)

Switching Power Supplies

MPS Series/MPW Series

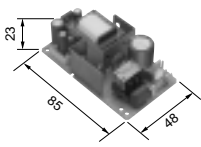

For SOHO Equipment

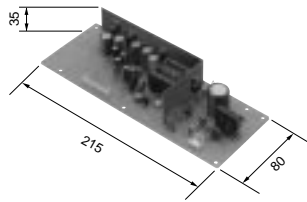

For Communication Equipment

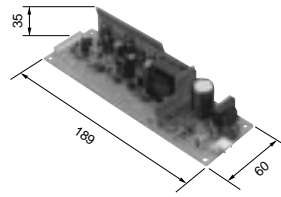

For Audio Visual Equipment

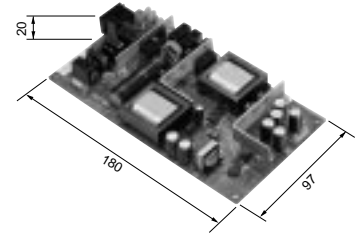

For LCD TV

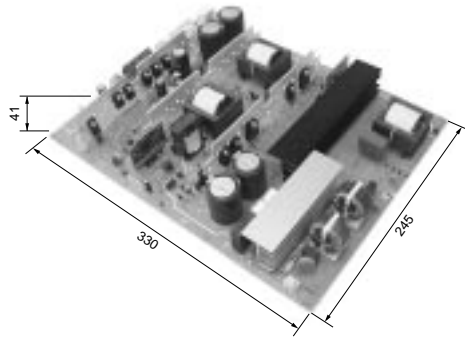

For High-inch LCD Panel

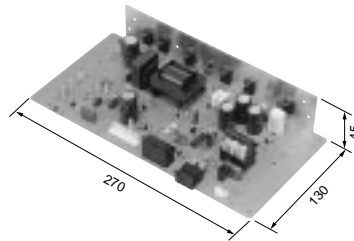

For PBX

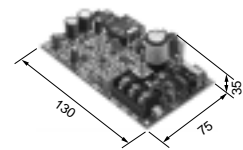

Cell Stations

(in mm)

● **Features**

1. Small size, light weight, high reliability.
2. Low noise, overload protection up to safety standard.

Application	Input Voltage	Output Voltage	Safety Standard	EMI Standard	Remarks	
SOHO Equipment	115V AC	5V 0.3A / 24V 4.5A (PEAK) 24V 1.0A (RATE)	Facsimile voluntary standard, UL, CSA IEC	VCCI, FCC	Models which provide a power-saving standby mode are also available.	
	230V AC			VDE, CISPR		
Communication Equipment	115V AC	3.3V 0.2A / 5V 0.6A / 9V 0.9A / 15V 0.2A / 25V 0.05A / -27V 0.05A	UL, CSA IEC	VCCI, FCC		
	230V AC			VDE, CISPR		
Audio Visual Equipment	115V AC	3.3V 1A / 5V 1.5A / 9V 0.6A / 15V 0.3A / 25V 0.05A / -30V 0.05A	UL, CSA IEC	VCCI, FCC		
	230V AC			VDE, CISPR		
LCD TV	100V/115V/ 230V AC	24V 7.5A (for 37 inch) 30V / 15V / 10V 6V / 5V (Total 70W)	UL, CSA, IEC	VCCI, FCC, CISPR		• W/W input type is available. Models which provide a power-saving standby mode are also available.
For High-inch LCD Panel	100/ 115V AC/ 230V	24V 20A 15V 4A 5V 0.3A	Electrical Appliance and Materials Safety Law of Japan, UL, CSA, IEC	VCCI, FCC, VDE, CISPR		
PBX	115V/230V	5V 5.0A 12V 1.0A -48V 2.5A	UL, IEC	FCC, CISPR		Provided with Pb battery charging function.
Cell Stations	100V AC	7.2V 1.3A	Electrical Appliance and Materials Safety Law of Japan	VCCI		Provided with Ni-Cd battery charging function.
LCD Projector	100V/120V/ 230V	17V 0.8A / 13V 1.6A / 5V 1.6A / 36V 0.47A	Electrical Appliance and Materials Safety Law of Japan, UL IEC	VCCI, FCC	• Each system like LCD,DLP is available.	
				CISPR		

Power Supplies

11

⚠️Note • This PDF catalog is downloaded from the website of Murata Manufacturing co., Ltd. Therefore, it's specifications are subject to change or our products in it may be discontinued without advance notice. Please check with our sales representatives or product engineers before ordering.
• This PDF catalog has only typical specifications because there is no space for detailed specifications. Therefore, please approve our product specifications or transact the approval sheet for product specifications before ordering.

Ultra Low Profile Switching Power Supplies

MPA Series/MPN Series

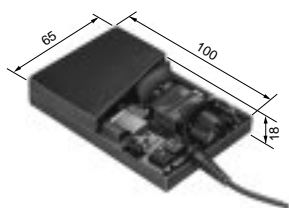

AC Adapters

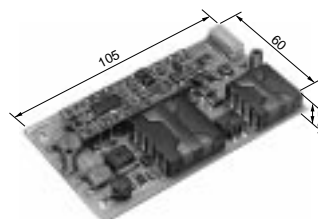

For Communication Equipment
(board-on type)

(in mm)

● Features

1. Built-in ultra-low-profile multilayer transformer.
2. Ultra-low-profile, high reliability, light weight.
3. Low noise, overload protection up to safety standard.

Application	Input Voltage	Output Voltage	Safety Standard	EMI Standard
AC Adapters	115V AC	15V 1.5A	UL, CSA	VCCI, FCC
	230V AC		IEC	VDE, CISPR
Communication Equipment (board-on type)	-48V DC	-5V 10A	Electrical Appliance and Materials Safety Law of Japan	VCCI
		-3.3V 15A		

DC-DC Converters

No Isolation Type



MYUSP3R303FMP



MPDRX312S



MPDRX301S



MPDRX002S



MPDRX103S



MPDTY11*S

Part Number	Package	Input Voltage (V)	Nominal Output Power (W)	Output Voltage (V)	Current (A)	Efficiency	Size (mm) L x W x T
MPDTH03050WAS/H	WAS=SMD WAH=Through hole	2.95 to 3.65	15	0.8 to 2.5	6	94% (2.5V/4A)	22.1x12.6x9.1 (8.5)
MPDTH05050WAS/H		4.5 to 5.5	21.6	0.8 to 3.6		95% (3.3V/4A)	
MPDTH12050WAS/H		10.8 to 13.2	33	1.2 to 5.5		93% (5V/4A)	
MPDTH03060WAS/H		2.95 to 3.65	25	0.8 to 2.5	10	93% (2.5V/7A)	25.3x15.8x9.6 (9.0)
MPDTH05060WAS/H		4.5 to 5.5	36	0.8 to 3.6		94% (3.3V/7A)	
MPDTH12060WAS/H		10.8 to 13.2	55	1.2 to 5.5		94% (5V/8A)	

() in the size column shows the size of Through hole goods.

Continued on the following page.

△Note • This PDF catalog is downloaded from the website of Murata Manufacturing co., ltd. Therefore, it's specifications are subject to change or our products in it may be discontinued without advance notice. Please check with our sales representatives or product engineers before ordering.
• This PDF catalog has only typical specifications because there is no space for detailed specifications. Therefore, please approve our product specifications or transact the approval sheet for product specifications before ordering.

Part Number	Package	Input Voltage (V)	Nominal Output Power (W)	Output Voltage (V)	Current (A)	Efficiency	Size (mm) L x W x T		
MPDTH03010WAS/H	WAS=SMD WAH=Through hole	2.95 to 3.65	37.5	0.8 to 2.5	15	93% (2.5V/10A)	34.8x15.8x9.6 (9.0)		
MPDTH05010WAS/H		4.5 to 5.5	54	0.8 to 3.6		95% (3.3V/10A)			
MPDTH12010WAS/H		10.8 to 13.2	66	1.2 to 5.5	12	94% (5V/10A)			
MPDTH03020WAS/H		2.95 to 3.65	55	0.8 to 2.5	22	95% (2.5V/10A)	38.0x22.1x9.6 (9.0)		
MPDTH05020WAS/H		4.5 to 5.5	79.2	0.8 to 3.6		95% (3.3V/14A)			
MPDTH12020WAS/H		10.8 to 13.2	99	1.2 to 5.5	18	95% (5V/12A)			
MPDTH03030WAS/H		2.95 to 3.65	75	0.8 to 2.5	30	93% (2.5V/20A)	34.8x28.5x9.6 (9.0)		
MPDTH05030WAS/H		4.5 to 5.5	108	0.8 to 3.6		94% (3.3V/20A)			
MPDTH12030WAS/H		10.8 to 13.2	143	1.2 to 5.5	26	94.5% (5V/18A)			
MPDTH04040WAS/H		2.95 to 5.5	216	0.8 to 3.6	60	96% (3.3V/35A)	51.9x26.5x9.4 (9.1)		
MPDTH12040WAS/H		8.0 to 14.0	275	0.8 to 5.5	50	95% (3.3V/35A)			
MPDTH03050YAS/H*		2.95 to 3.65	10.8	0.55 to 1.8	6	88% (1.25V/4A)	22.1x12.6x9.1 (8.5)		
MPDTH05050YAS/H*		4.5 to 5.5				87% (1.25V/4A)			
MPDTH12050YAS/H*		10.8 to 13.2				84% (1.25V/4A)			
MPDTH03060YAS/H*		2.95 to 3.65	18		10	86% (1.25V/8A)	25.3x15.8x9.6 (9.0)		
MPDTH05060YAS/H*		4.5 to 5.5				83% (1.25V/8A)			
MPDTH12060YAS/H*		10.8 to 13.2	27		15	88% (1.25V/10A)	34.8x15.8x9.6 (9.0)		
MPDTH03010YAS/H*		2.95 to 3.65				85% (1.25V/10A)			
MPDTH05010YAS/H*		4.5 to 5.5	12		85% (1.25V/10A)				
MPDTH12010YAS/H*		10.8 to 13.2	21.6		12	85% (1.25V/10A)			
MPDXY402S	SMD	3.0 to 5.5	52.8		0.75 to 3.3	16	95% (3.3V/7A)	33.0x13.5x8.0	
MPDXY411S		4.5 to 5.5	23.1	0.8 to 3.3	7	94% (3.3V/7A)	20.3x11.4x6.2		
MPDXY412S		3.0 to 3.6	17.5	0.8 to 2.5		93% (2.5V/7A)			
MPDXY413S		10.0 to 14.0	33	0.8 to 5.5	6	94% (3.3V/6A)			
MPDRX002S		3.0 to 5.5	28.8	0.8 to 1.8	16	90% (1.8V/16A)	33.0x13.5x8.5		
MPDRX004S		7.0 to 14.0	21.6		12	88% (1.8V/12A)			
MPDRX103S	SIL	10.8 to 13.2	28.8	0.8 to 1.8	16	86% (1.8V/16A)	50.8x5.8x14.0		
MPDRX104S			39.6	1.5 to 3.3	12	88% (3.3V/12A)			
MPD6S022S		3.0 to 5.5	10.8	1.1 to 3.6	3	96% (3.3V/1A)	20.0x9.0x21.0		
MPDXY011S	SIL	2.97 to 3.63	6	1	6	84%	33.0x5.8x24.0		
MPDXY012S			7.2	1.2		87%			
MPDXY013S			9	1.5		89%			
MPDXY014S			10.8	1.8		90%			
MPDXY015S			12	2		92%			
MPDXY016S			15	2.5		93%			
MPDXY021S		4.5 to 5.5	6	1	82%				
MPDXY022S			7.2	1.2	84%				
MPDXY023S			9	1.5	86%				
MPDXY024S			10.8	1.8	88%				
MPDXY025S			12	2	89%				
MPDXY026S			15	2.5	91%				
MPDXY027S		19.8	3.3	93%					
MPDXY111S		SMD	2.97 to 3.63	6	1	6		84%	33.8x15.4x6.0
MPDXY112S				7.2	1.2			87%	
MPDXY113S				9	1.5			89%	
MPDXY114S	10.8			1.8	90%				
MPDXY115S	12			2	92%				
MPDXY116S	15			2.5	93%				
MPDXY121S	4.5 to 5.5		6	1	82%				
MPDXY122S			7.2	1.2	84%				
MPDXY123S			9	1.5	86%				
MPDXY124S			10.8	1.8	88%				
MPDXY125S			12	2	89%				
MPDXY126S			15	2.5	91%				

* for DDR

() in the size column shows the size of Through hole goods.

Continued on the following page.

Continued from the preceding page.

Part Number	Package	Input Voltage (V)	Nominal Output Power (W)	Output Voltage (V)	Current (A)	Efficiency	Size (mm) L x W x T	
MPDTY127S	SMD	4.5 to 5.5	19.8	3.3	6	93%	33.8x15.4x6.0	
MPDTY102S		3.0 to 5.5	10	0.8 to 5.0	2	93% (2.4V/1A)	21.3x16.4x4.2	
MYUSP3R303FMP			9.9	0.7 to 3.3	3	94% (3.3V/1A)	11.0x8.5x5.6	
MYFSP3R303FMS			91% (3.3V/1A)					
MPDTY301S			4.5 to 5.5	23.1	0.8 to 3.3	7	95% (3.3V/7A)	27.8x15.4x4.2
MPDTY302S		3.0 to 3.6	17.5	0.8 to 2.5	94% (2.5V/7A)			
MPDTY303S		6.5 to 14.0	44	0.8 to 5.5	8	92% (3.3V/8A)		
MPDTY311S		4.5 to 5.5	52.8	0.8 to 3.3	16	94% (3.3V/16A)		
MPDTY312S		3.0 to 3.6	40	0.8 to 2.5		91.5% (2.5V/16A)		
MPDRX301S		5.6 to 14.0	47.2	1.6 to 3.63	13	90% (3.3V/13A)	21.9x21.7x4.2	
MPDRX302S			21.5	0.8 to 1.65		82% (1.2V/13A)		
MPDRX303S			94.4	1.6 to 3.63	26	90% (3.3V/26A)	26.8x26.8x7.0	
MPDRX304S			42.9	0.8 to 1.65		84% (1.2V/26A)		
MPDRX312S		3.0 to 5.5	28.8	0.8 to 1.8	16	86.5% (1.8V/16A)	27.8x15.4x4.2	
MPDRX313S		4.5 to 5.5	85.8	0.8 to 3.3	26	85.4% (1.2V/20A)	26.8x26.8x7.0	
MPDRX021S			18	0.85 to 1.8	10	87% (1.2V/10A)	22.1x15.8x8.4	
MPDRX307S		6.2 to 13.2	23.6	1.6 to 3.63	6.5	91% (3.3V/5A)	20.2x17.6x4.2	
MPDRX308S			10.7	0.8 to 1.6		82% (1.2V/5A)		
MPD6M031S		10.8 to 13.2	30	1.2 to 5.0	6	92% (2.5V/6A)	29.6x20.9x7.2	
MPDTY321S		4.5 to 5.5	13.2	0.8 to 3.3	4	93% (3.3V/4A)	15.8x15.4x2.9	
MYSSM0123ECEN		17 to 40	42	5.0 to 12.0	3.5	97% (12V/3.5A)	30.2x20.9x12.0	
MYSSM3R31ECEN		21.6 to 26.4	4.95	3.3	1.5	88%		

() in the size column shows the size of Through hole goods.

DC-DC Converters

Isolation Type

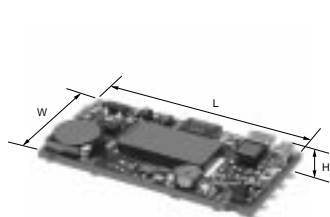

MPD5D01*S Series

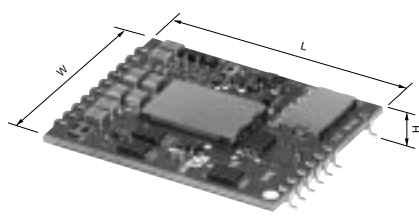

MPD6D10*S/11*S/20*S Series
MPD7D06*S Series

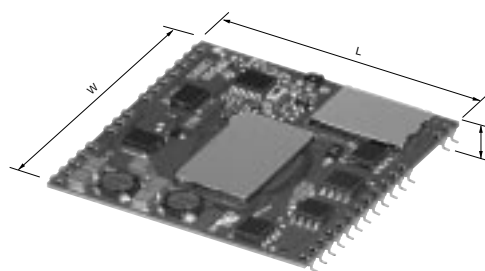

MPD6D12*S Series
MPD7D05*S/13*S/12*S Series

Part Number	Package	Input Voltage (V)	Nominal Output Power (W)	Output Voltage (V)	Current (A)	Efficiency	Size (mm) L x W x T
MPDKN004S	Through hole	36.0 to 75.0	50	1.8	15	85%	57.0x36.8x5.5
MPDKN006S				2.5		87%	
MPDKN007S				3.3		88%	
MPDKN008S				5	89%		
MPD5D013S	SMD	36.0 to 75.0	5	1.5	0.8	70%	27.0x14.6x4.7
MPD5D014S				1.8	1	75%	
MPD5D016S				2.5	1.2	80%	
MPD5D017S				3.3	1.5	84%	
MPD5D018S				5	1	85%	

Continued on the following page.

Note • This PDF catalog is downloaded from the website of Murata Manufacturing co., ltd. Therefore, it's specifications are subject to change or our products in it may be discontinued without advance notice. Please check with our sales representatives or product engineers before ordering.
• This PDF catalog has only typical specifications because there is no space for detailed specifications. Therefore, please approve our product specifications or transact the approval sheet for product specifications before ordering.

Continued from the preceding page.

Part Number	Package	Input Voltage (V)	Nominal Output Power (W)	Output Voltage (V)	Current (A)	Efficiency	Size (mm) L x W x T		
MPD6D101S	SMD	36.0 to 75.0	10	12	0.8	88%	39.9x22.4x4.2		
MPD6D102S				1.2	3.5	79%			
MPD6D103S				1.5		82%			
MPD6D104S				1.8	3	86%			
MPD6D105S				2		88%			
MPD6D106S				2.5					
MPD6D107S				3.3	2	89%			
MPD6D108S				5					
MPD6D109S				5.2					
MPD6D111S				15	12	1.2		86%	39.9x31.2x4.2
MPD6D112S					1.2	5.2		82%	
MPD6D113S					1.5			84%	
MPD6D114S			1.8		4.5	87%			
MPD6D116S			2.5			88%			
MPD6D117S			3.3						
MPD6D118S			5		3	90%			
MPD6D119S			5.2						
MPD6D122S			30		1.2	12	84%	45.0x45.0x4.4	
MPD6D123S					1.5	11	86%		
MPD6D124S					1.8		88%		
MPD6D126S					2.5	10	89%		
MPD6D127S				3.3	9	91%			
MPD6D128S				5	6	92%			
MPD7D067S			35	3.3	10.6	90%	39.3x30.1x8.0		
MPD7D068S				5	7				
MPD7D052S			50	1.2	16	86%	45.0x36.2x4.2		
MPD7D053S				1.5	17	84%			
MPD7D054S				1.8	16	86%			
MPD7D056S				2.5	15	89%			
MPD7D057S				3.3		90%			
MPD7D058S				5	10				
MPD6D207S			18.0 to 36.0	30	3.3	9	91%	39.3x30.1x8.0	
MPD6D209S					5	6			
MPD7D137S			36.0 to 75.0	80	3.3	24	92%	45.0x45.0x8.5	
MPD7D138S					5	16	93%		
MPD7D128S					100	20	92.5%		

Applicable Products with Power Supplies

Ionizer Modules (Ionissimo™)

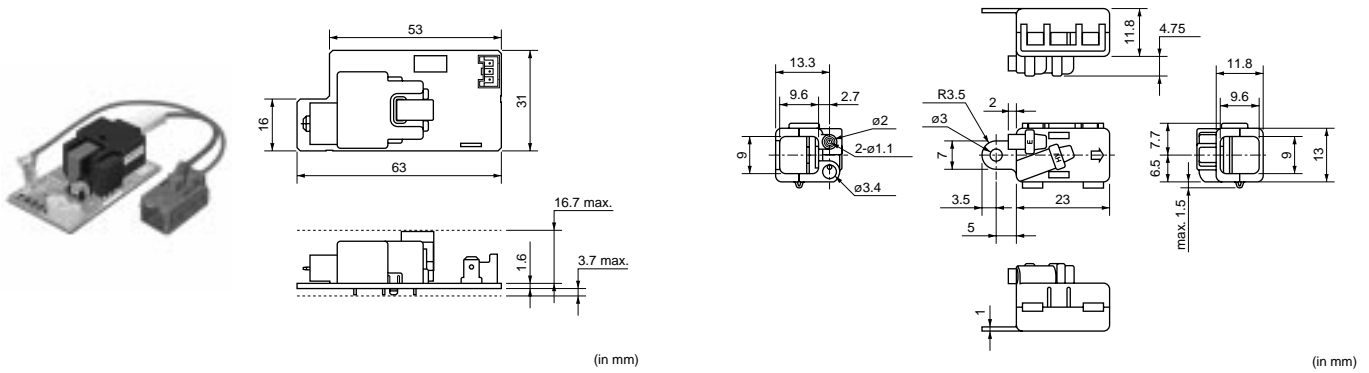

Part Number	Input Voltage (V)	Consumption Electricity (W)	Ion Amount (pcs/cc)	Ozone Amount	Operating Temperature Range	Operating Humidity Range
MHM301-□□	12	0.4	500,000 or more	0.01mg/H or less	0 to +50°C	30 to 80%RH
MHM302-□□	12	0.6	500,000 or more	Max. 1.0mg/H	0 to +50°C	30 to 80%RH

Note • This PDF catalog is downloaded from the website of Murata Manufacturing co., Ltd. Therefore, it's specifications are subject to change or our products in it may be discontinued without advance notice. Please check with our sales representatives or product engineers before ordering.
 • This PDF catalog has only typical specifications because there is no space for detailed specifications. Therefore, please approve our product specifications or transact the approval sheet for product specifications before ordering.

12

Sound Components

Piezoelectric Sounders

Piezoelectric Ringers (PIEZORINGER®)

Piezoelectric Buzzers

Piezoelectric Diaphragms

● Part Numbering

**Piezoelectric Sounders/Piezoelectric Buzzers
/Piezoelectric Ringers (PIEZORINGER®)**

(Part Number) **PK M 13 E P YH 40 00 P -A0**
① ② ③ ④ ⑤ ⑥ ⑦ ⑧ ⑨ ⑩

- ① Product ID
- ② Product

Code	Product
M	Sounder, Ringer
B	Buzzer

- ③ Outer Dimensions
- ④ Drive

Code	Drive
E	External-Drive
S	Self-Drive

- ⑤ Outer Electrode Style
- ⑥ Structure

Code	Structure
T <input type="checkbox"/>	Standing Type
P <input type="checkbox"/>	Flat Type Auto-assemble
Y <input type="checkbox"/>	Flat Type/Available for Taping
C <input type="checkbox"/>	Flat Type/Semi-auto-assemble
<input type="checkbox"/>	Exclude above mentioned

means specification of outer electrode.

- ⑦ Oscillating Frequency Type
- ⑧ Individual Specification Code
- ⑨ Special Quality Guarantee

Code	Special Quality Guarantee
P	Post Plated Terminal
—	Blank

- ⑩ Packaging

SMD Piezoelectric Sounder

(Part Number) **PK LCS 1212 E 40 01 -R1**
① ② ③ ④ ⑤ ⑥ ⑦

- ① Product ID
- ② Product
- ③ Dimensions
- ④ Drive
- ⑤ Oscillating Frequency Type

Code	Oscillating Frequency Type
40	Expressed resonant frequency by two-digit alphanumerics. The unit is in 100 hertz (Hz). In case of 4kHz (4000Hz), expressed as "40".

- ⑥ Individual Specification Code
- ⑦ Packaging

Piezoelectric Diaphragms

(Part Number) **7 N B -31R2 DM -1R5 L 10**
① ② ③ ④ ⑤ ⑥ ⑦ ⑧ ⑨

- ① Product ID
- ② Material of Metal Plate

Code	Metal Plate Material
B	Brass
N	Nickel Alloy
S	SUS

- ③ Product
- ④ Metal Plate Diameter
- ⑤ Material of electrode
- ⑥ Resonant Frequency Type

Code	Resonant Frequency (kHz)
-1R5	A hyphen (-) and three digits alphanumerics express resonant frequency. A decimal point is expressed by the capital letter "R".

If there is no decimal point, the decimal point is omitted.

- ⑦ With Feedback Electrode

Code	With Feedback Electrode
C	With Feedback Electrode
—	Without Feedback Electrode

- ⑧ Product Specification

Code	Product Specification
L	With lead (available for RoHS)
—	No lead (omitted)

- ⑨ Individual Specification Code

Piezoelectric Sounders

External-Drive

● Pin Type



PKM13EPYH4002-B0

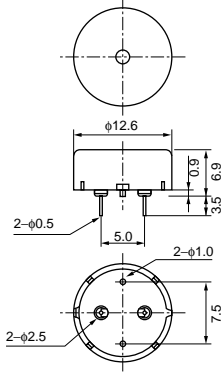

(In : mm)
Tol. : ±0.5



PKM17EPP-2002-B0

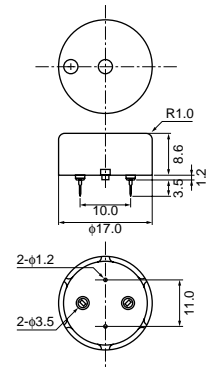

(in mm)
Tol. : ±0.5



PKM17EPPH4001-B0

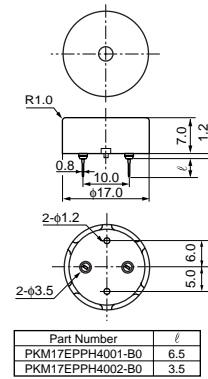

Part Number	ℓ
PKM17EPPH4001-B0	6.5
PKM17EPPH4002-B0	3.5

(In : mm)
Tol. : ±0.5



PKM22EPH2001

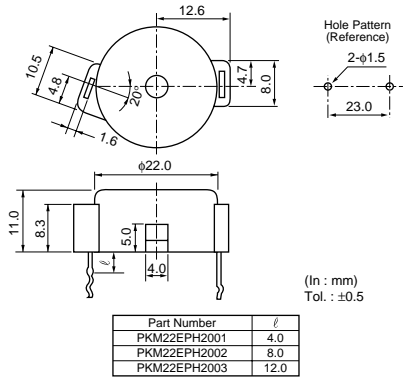

Part Number	ℓ
PKM22EPH2001	4.0
PKM22EPH2002	8.0
PKM22EPH2003	12.0

(In : mm)
Tol. : ±0.5



PKM22EPPH2001-B0

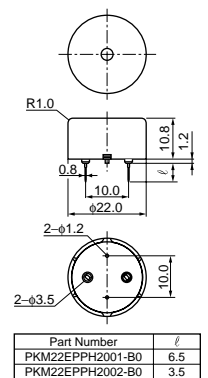

Part Number	ℓ
PKM22EPPH2001-B0	6.5
PKM22EPPH2002-B0	3.5

(In : mm)
Tol. : ±0.5



PKM22EPPH4001-B0

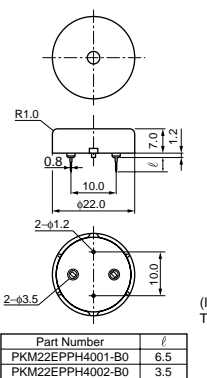

Part Number	ℓ
PKM22EPPH4001-B0	6.5
PKM22EPPH4002-B0	3.5

(In : mm)
Tol. : ±0.5



PKM22EPPH4007-B0

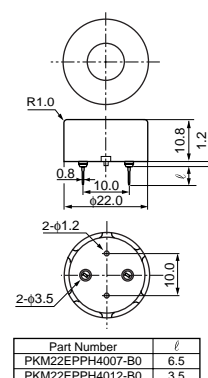

Part Number	ℓ
PKM22EPPH4007-B0	6.5
PKM22EPPH4012-B0	3.5

(In : mm)
Tol. : ±0.5



PKM22EPTH2001-B0

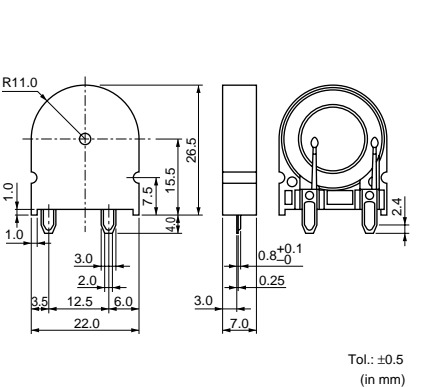

Part Number	ℓ
PKM22EPTH2001-B0	6.5
PKM22EPTH2002-B0	3.5

(In : mm)
Tol. : ±0.5

△Note • This PDF catalog is downloaded from the website of Murata Manufacturing co., ltd. Therefore, it's specifications are subject to change or our products in it may be discontinued without advance notice. Please check with our sales representatives or product engineers before ordering.
• This PDF catalog has only typical specifications because there is no space for detailed specifications. Therefore, please approve our product specifications or transact the approval sheet for product specifications before ordering.

Part Number	Sound Pressure Level (dB)	Operating Voltage Range	Capacitance (nF)
PKM13EPYH4002-B0	70 min.[3Vp-p,4kHz,square wave,10cm]	30.0 Vp-p max.	5.5 ±30%[1kHz]
PKM17EPP-2002-B0	70 min.[3Vo-p,2kHz,square wave,10cm]	25.0 Vo-p max.[with polarity]	34.0 ±30%[120Hz]
PKM17EPPH4001-B0	72 min.[3Vp-p,4kHz,square wave,10cm]	25.0 Vp-p max.	7.0 ±30%[1kHz]
PKM22EPH2001	75 min.[3Vp-p,2kHz,square wave,10cm]	25.0 Vp-p max.	17.0 ±30%[120Hz]
PKM22EPPH2001-B0	70 min.[3Vp-p,2kHz,square wave,10cm]	30.0 Vp-p max.	19.0 ±30%[120Hz]
PKM22EPPH4001-B0	75 min.[3Vp-p,4kHz,square wave,10cm]	30.0 Vp-p max.	12.0 ±30%[1kHz]
PKM22EPPH4005-B0	75 min.[3Vp-p,4kHz,square wave,10cm]	30.0 Vp-p max.	12.0 ±30%[1kHz]
PKM22EPPH4007-B0	85 min.[3Vp-p,4kHz,square wave,10cm]	30.0 Vp-p max.	12.0 ±30%[1kHz]
PKM22EPH2001-B0	70 min.[3Vp-p,2kHz,square wave,10cm]	25.0 Vp-p max.	19.0 ±30%[120Hz]

● Pin Type Taping

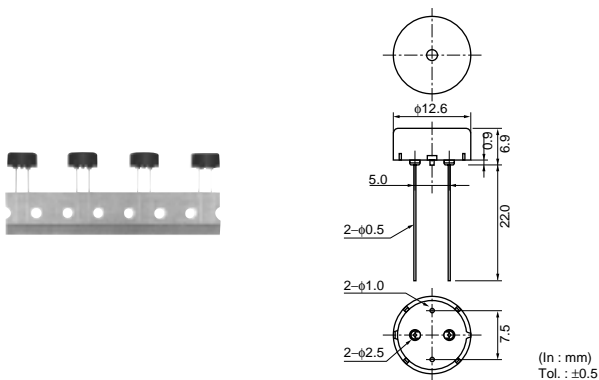

Part Number	Sound Pressure Level (dB)	Operating Voltage Range	Capacitance (nF)
PKM13EPYH4000-A0	70 min.[3Vp-p,4kHz,square wave,10cm]	30.0 Vp-p max.	5.5 ±30%[1kHz]

● Lead Wire Type

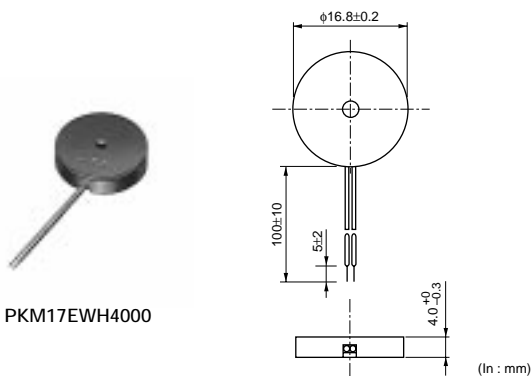

PKM17EWH4000

Part Number	Sound Pressure Level (dB)	Operating Voltage Range	Capacitance (nF)
PKM17EWH2001	72 min.[3Vp-p,2kHz,square wave,10cm]	7.0 Vp-p max.	40.0 ±30%[120Hz]
PKM17EWH4000	75 min.[3Vp-p,4kHz,square wave,10cm]	25.0 Vp-p max.	9.5 ±30%[1kHz]

Note • This PDF catalog is downloaded from the website of Murata Manufacturing co., ltd. Therefore, it's specifications are subject to change or our products in it may be discontinued without advance notice. Please check with our sales representatives or product engineers before ordering.
 • This PDF catalog has only typical specifications because there is no space for detailed specifications. Therefore, please approve our product specifications or transact the approval sheet for product specifications before ordering.

Piezoelectric Sounders

SMD

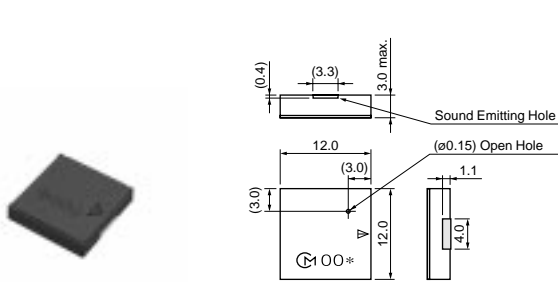

PKLCS1212E2000-R1
PKLCS1212E20A0-R1

() : Ref. only
(in mm)
Tol. ±0.2

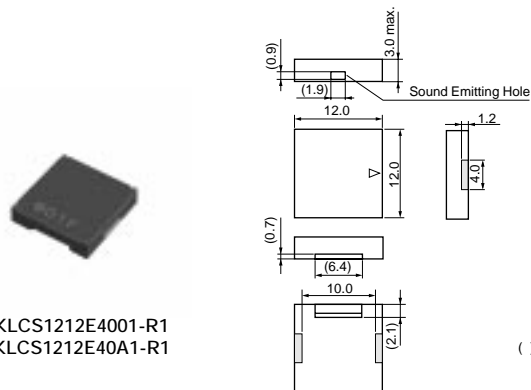

PKLCS1212E4001-R1
PKLCS1212E40A1-R1

() : Ref. only
(in mm)
Tol.: ±0.2

Part Number	Sound Pressure Level (dB)	Operating Voltage Range (Vp-p)	Operating Temperature Range	Storage Temperature Range	Use
PKLCS1212E2000-R1	70 min.[3Vp-p,2kHz,square wave,10cm]	25 max.	-20 to +70°C	-30 to +80°C	For consumer electronics
PKLCS1212E20A0-R1	70 min.[3Vp-p,2kHz,square wave,10cm]	25 max.	-40 to +85°C	-40 to +85°C	For automotive electronics
PKLCS1212E4001-R1	75 min.[3Vp-p,4kHz,square wave,10cm]	25 max.	-20 to +70°C	-30 to +80°C	For consumer electronics
PKLCS1212E40A1-R1	75 min.[3Vp-p,4kHz,square wave,10cm]	25 max.	-40 to +85°C	-40 to +85°C	For automotive electronics

Piezoelectric Sounders

Self-Drive

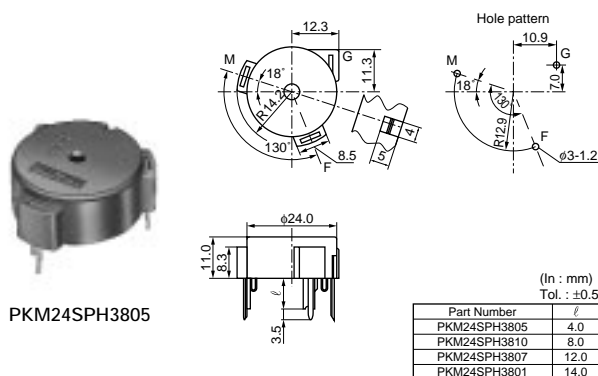

PKM24SPH3805

Part Number	ℓ (in : mm)
PKM24SPH3805	4.0
PKM24SPH3810	8.0
PKM24SPH3807	12.0
PKM24SPH3801	14.0

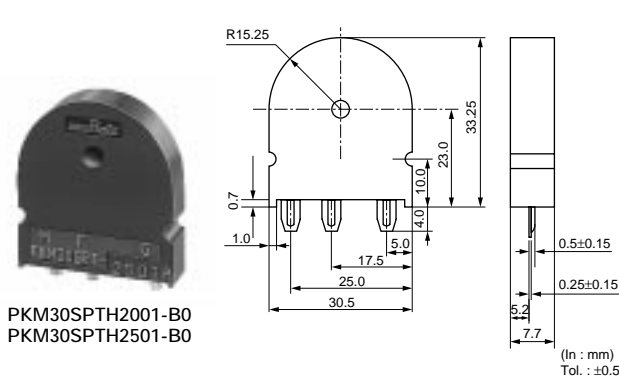

PKM30SPH2001-B0
PKM30SPH2501-B0

(in : mm)
Tol. : ±0.5

Part Number	Sound Pressure Level (dB)	Oscillating Frequency (kHz)	Current Consumption (mA)	Operating Voltage Range
PKM24SPH3805	90 min.[12Vdc,10cm]	3.8 ±0.4kHz	12 max.	3.0Vdc to 20.0 Vdc
PKM30SPH2001-B0	75 min.[12Vdc,10cm]	2.0 ±0.3kHz	20 max.	3.0Vdc to 20.0 Vdc
PKM30SPH2501-B0	75 min.[12Vdc,10cm]	2.5 ±0.3kHz	20 max.	3.0Vdc to 20.0 Vdc

△Note • This PDF catalog is downloaded from the website of Murata Manufacturing co., ltd. Therefore, it's specifications are subject to change or our products in it may be discontinued without advance notice. Please check with our sales representatives or product engineers before ordering.
• This PDF catalog has only typical specifications because there is no space for detailed specifications. Therefore, please approve our product specifications or transact the approval sheet for product specifications before ordering.

Piezoelectric Ringer (PIEZORINGER®)

● Pin Type

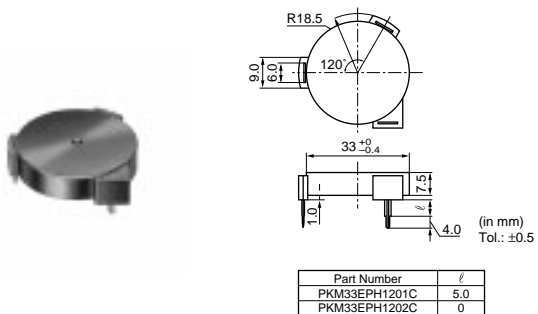

Part Number	Sound Pressure Level (dB)	Operating Voltage Range	Capacitance (nF)
PKM33EPH1201C	68 min.[30Vp-p, 1.2kHz, square wave, 1m]	40.0 Vp-p max.	40.0 ±30%[120Hz]

Operating Temp. Range: -20 to +70°C

● Lead Wire Type

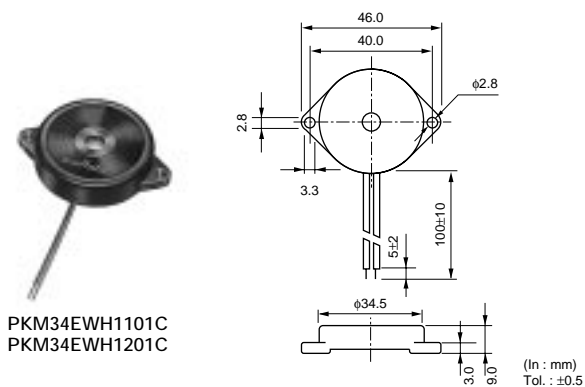

Part Number	Sound Pressure Level (dB)	Operating Voltage Range	Capacitance (nF)
PKM34EWH1101C	70 min.[30Vp-p, 1.1kHz, square wave, 1m]	40.0 Vp-p max.	40.0 ±30%[120Hz]
PKM34EWH1201C	70 min.[30Vp-p, 1.2kHz, square wave, 1m]	60.0 Vp-p max.	32.0 ±30%[120Hz]
PKM44EWH1001C	75 min.[30Vp-p, 1kHz, square wave, 1m]	30.0 Vp-p max.	68.0 ±30%[120Hz]

Operating Temp. Range: -20 to +70°C

⚠Note • This PDF catalog is downloaded from the website of Murata Manufacturing co., ltd. Therefore, it's specifications are subject to change or our products in it may be discontinued without advance notice. Please check with our sales representatives or product engineers before ordering.
• This PDF catalog has only typical specifications because there is no space for detailed specifications. Therefore, please approve our product specifications or transact the approval sheet for product specifications before ordering.

Piezoelectric Buzzers

● Pin Type



PKB24SPCH3601-B0

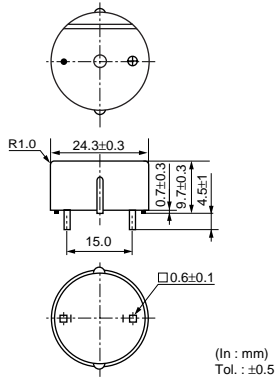

Part Number	Sound Pressure Level (dB)	Oscillating Frequency (kHz)	Current Consumption (mA)	Operating Voltage Range
PKB24SPCH3601-B0	90 min.[12Vdc,10cm]	3.6 ±0.5kHz	16 max.	3.0Vdc to 15.0 Vdc

Operating Temp. Range: -20 to +70°C

● Lead Wire Type

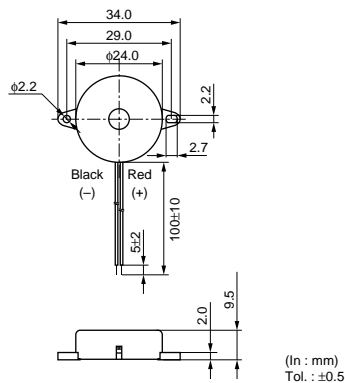

Part Number	Sound Pressure Level (dB)	Oscillating Frequency (kHz)	Current Consumption (mA)	Operating Voltage Range
PKB24SWH3301	80 min.[12Vdc,10cm]	3.3 ±0.5kHz	12 max.	3.0Vdc to 20.0 Vdc

Operating Temp. Range: -20 to +70°C

△Note • This PDF catalog is downloaded from the website of Murata Manufacturing co., ltd. Therefore, it's specifications are subject to change or our products in it may be discontinued without advance notice. Please check with our sales representatives or product engineers before ordering.
• This PDF catalog has only typical specifications because there is no space for detailed specifications. Therefore, please approve our product specifications or transact the approval sheet for product specifications before ordering.

Piezoelectric Diaphragms

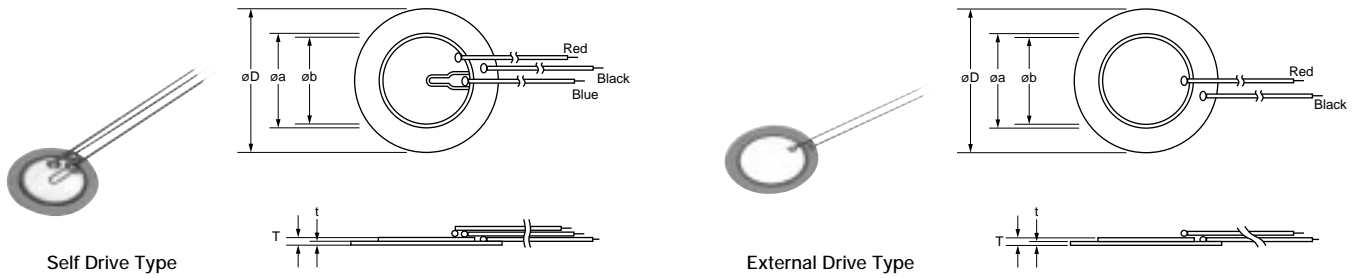

Part Number	Resonant Frequency (kHz)	Resonant Impedance (ohm)	Capacitance (nF)	Plate Size øD (mm)	Element Size øa (mm)	Electrode Size øb (mm)	Thickness T (mm)	Plate Thickness t (mm)	Plate Material	Drive Type
7BB-12-9	9.0 ±1.0kHz	1000 max.	8.0 ±30% [1kHz]	12.0	9.0	8.0	0.22	0.10	Brass	External Drive
7BB-15-6	6.0 ±1.0kHz	800 max.	10.0 ±30% [1kHz]	15.0	10.0	9.0	0.22	0.10	Brass	External Drive
7BB-20-3	3.6 ±0.6kHz	500 max.	20.0 ±30% [1kHz]	20.0	14.0	12.8	0.22	0.10	Brass	External Drive
7BB-20-6	6.3 ±0.6kHz	350 max.	10.0 ±30% [1kHz]	20.0	14.0	12.8	0.42	0.20	Brass	External Drive
7BB-20-6C	6.3 ±0.6kHz	500 max.	8.5 ±30% [1kHz]	20.0	14.0	12.8	0.42	0.20	Brass	Self Drive
7BB-20-6CLO	6.3 ±0.6kHz	800 max.	8.5 ±30% [1kHz]	20.0	14.0	12.8	0.42	0.20	Brass (with Lead Wire:AWG32 Length 50mm)	Self Drive
7BB-20-6LO	6.3 ±0.6kHz	1000 max.	10.0 ±30% [1kHz]	20.0	14.0	12.8	0.42	0.20	Brass (with Lead Wire:AWG32 Length 50mm)	External Drive
7BB-27-4	4.6 ±0.5kHz	200 max.	20.0 ±30% [1kHz]	27.0	19.7	18.2	0.54	0.30	Brass	External Drive
7BB-27-4C	4.6 ±0.5kHz	200 max.	18.0 ±30% [1kHz]	27.0	19.7	18.2	0.54	0.30	Brass	Self Drive
7BB-27-4CLO	4.6 ±0.5kHz	350 max.	18.0 ±30% [1kHz]	27.0	19.7	18.2	0.54	0.30	Brass (with Lead Wire:AWG32 Length 50mm)	Self Drive
7BB-27-4LO	4.6 ±0.5kHz	300 max.	20.0 ±30% [1kHz]	27.0	19.7	18.2	0.54	0.30	Brass (with Lead Wire:AWG32 Length 50mm)	External Drive
7BB-35-3	2.8 ±0.5kHz	200 max.	30.0 ±30% [1kHz]	35.0	25.0	23.0	0.53	0.30	Brass	External Drive
7BB-35-3C	2.8 ±0.5kHz	200 max.	26.0 ±30% [1kHz]	35.0	25.0	23.0	0.53	0.30	Brass	Self Drive
7BB-35-3CLO	2.8 ±0.5kHz	200 max.	26.0 ±30% [1kHz]	35.0	25.0	23.0	0.53	0.30	Brass (with Lead Wire:AWG32 Length 50mm)	Self Drive
7BB-35-3LO	2.8 ±0.5kHz	200 max.	30.0 ±30% [1kHz]	35.0	25.0	23.0	0.53	0.30	Brass (with Lead Wire:AWG32 Length 50mm)	External Drive
7BB-41-2	2.2 ±0.3kHz	250 max.	30.0 ±30% [1kHz]	41.0	25.0	23.0	0.63	0.40	Brass	External Drive
7BB-41-2C	2.2 ±0.3kHz	250 max.	24.0 ±30% [1kHz]	41.0	25.0	23.0	0.63	0.40	Brass	Self Drive
7BB-41-2CLO	2.2 ±0.3kHz	350 max.	24.0 ±30% [1kHz]	41.0	25.0	23.0	0.63	0.40	Brass (with Lead Wire:AWG32 Length 50mm)	Self Drive
7BB-41-2LO	2.2 ±0.3kHz	300 max.	30.0 ±30% [1kHz]	41.0	25.0	23.0	0.63	0.40	Brass (with Lead Wire:AWG32 Length 50mm)	External Drive
7NB-31R2-1	1.3 ±0.5kHz	300 max.	40.0 ±30% [120Hz]	31.2	19.7	18.2	0.22	0.10	Nickel Alloy	External Drive
7SB-34R7-3C	3.1 ±0.3kHz	150 max.	24.0 ±30% [1kHz]	34.7	25.0	23.4	0.50	0.25	Stainless	Self Drive

⚠Note • This PDF catalog is downloaded from the website of Murata Manufacturing co., Ltd. Therefore, it's specifications are subject to change or our products in it may be discontinued without advance notice. Please check with our sales representatives or product engineers before ordering.
• This PDF catalog has only typical specifications because there is no space for detailed specifications. Therefore, please approve our product specifications or transact the approval sheet for product specifications before ordering.

Capacitors

Monolithic Ceramic Capacitors (Lead Type)	150°C max. (for Automotive) (DC50V-DC100V)	RH Series.....100-102
---	--	-----------------------

Noise Suppression Products/EMI Suppression Filters

EMIFIL® (Inductor Type)	Chip Ferrite Bead	BLM03BD Series132-133 BLM15AX Series130-131 BLM18K Series138
EMIFIL® (LC Combined) Common Mode Choke Coil	Array Multilayer Type	NFA18S Series154-156 DLM11G Series163

Inductors (Coils)

Chip Inductor (Chip Coil)	for High Frequency Film Type	LQP02T Series214-215 LQP03T_02 Series215, 217
	for DC-DC Converter Wire Wound Type	LQH2MC_52 Series229 LQH3NPN_M0 Series230-231 LQH3NPN_J0 Series230-231
	for DC-DC Converter Multilayer Type	LQH44P Series232 LQM21P Series233

Resonators

Crystal Resonators	XRCGA Series257
--------------------	------------------------------

Sensors

Magnetic Switch	AS Series362-363
-----------------	-------------------------------

A

AC Line Filters	181
Adjustment Potentiometers	246
Antennas	328

B

Balanced Filters	295
Baluns	326
BGS Filters	315

C

Capacitors	26, 330
CERAFIL®	268, 278, 299
CERALOCK®	257
Ceramic Capacitors	26, 330
Ceramic Discriminators	277, 310
Ceramic Filters (CERAFIL®)	268, 278, 299
Ceramic Resonators (CERALOCK®)	257
Ceramic Traps	279
Ceramic Trimmer Capacitors	119
Chip Antennas	328
Chip Coils	200
Chip Ceramic Discriminators	277, 310
Chip Ceramic Filters (CERAFIL®)	268, 278, 299
Chip Ceramic Resonators (CERALOCK®)	257
Chip Ceramic Traps	279
Chip Dielectric Antennas	329
Chip EMI Suppression Filters (EMIFIL®)	129
Chip Ferrite Bead Array	142
Chip Ferrite Bead Inductors	129
Chip Monolithic Ceramic Capacitors	26
Chip Multilayer Antennas	328
Chip Multilayer Hybrid Baluns	326
Chip Multilayer Hybrid Couplers	323
Chip Multilayer Hybrid Dividers	325
Chip Multilayer LC Filters	289
Chip NTC Thermistors	377
Chip PTC Thermistors (POSISTOR®)	354, 368
Chip SAW Filters	296
Chip Trimmer Capacitors	119
Chip Trimmer Potentiometers	246
Choke Coils	160, 179, 181, 235
Coaxial Connectors	346
Coils	200
Common Mode Choke Coil	160, 179, 181
Connectors	346
Couplers	323
Crystal Resonators	257

D

DC-DC Converters	385
Dielectric Antennas	329
Dielectric Band Pass Filters (GIGAFIL®)	286
Dielectric Duplexers (GIGAFIL®)	286
Dielectric Filters (GIGAFIL®)	288
Disc Ceramic Capacitors	104

Discriminators	277, 310
Dividers	325

E

EMIFIL®	129
EMIGUARD®	179
EMI Suppression Filters (EMIFIL®)	129

F

Ferrite Bead	129
Ferrite Bead Inductors	129, 168
Ferrite Core	189
Filters	129, 268, 286
Fresnel Lens	356

G

GIGAFIL®	286
Gyro Sensors	360

H

Heaters	368
High Frequency Coaxial Connectors	346
High Frequency Single Layer Monolithic Capacitors	330
High Voltage Ceramic Capacitors	104, 116
High Voltage Resistors	245
Hybrid Baluns	326
Hybrid Choke Coils	184
Hybrid Couplers	323
Hybrid Dividers	325

I

Inductors	129, 168
Ionizer Modules (Ionissimo™)	389
Isolators	321

L

Line Filters	181
--------------------	-----

M

Magnetic Pattern Recognition Sensors	362
Magnetic Switch	362
Microchip Capacitors	342
Microwave Absorber	188
Microwave Isolators	321
Monolithic Ceramic Capacitors	26, 330
Multilayer LC Filters	289

N

Noise Filters	129
NTC Thermistors	377

P

Piezoelectric Buzzers	397
Piezoelectric Diaphragms	398
Piezoelectric Sound Components	393
Piezoelectric Sounders	393

Piezoelectric Ringers (PIEZORINGER®)	396
PIEZORINGER®	396
Potentiometers	246
Power Supplies	384
PTC Thermistors (POSISTOR®)	354, 368
Pyroelectric Infrared Sensors	356

R

Resistors	245
Resonators	257
R Networks	245
Rotary Position Sensors	361
Rotary Sensors	361
RUSUB®	345

S

SAW Duplexers	287
SAW Filters	296
SAW Traps	280
Safety Standard Certified Capacitors	89, 110
Semiconductive Magnetic Sensors	362
Sensors	353
Shock Sensors	360
SMD Piezoelectric Sounders	395
Surface Acoustic Wave Filters	296
Switching Power Supplies	384

T

Thermistors	354, 368
Thin Film Circuit Substrate (RUSUB®)	345
Traps	279
TRIMCAP®	119
Trimmer Capacitors (TRIMCAP®)	119
Trimmer Potentiometers	246

U

Ultrasonic Sensors	357
--------------------------	-----

Part Number	Page
A	
ANC	Chip Dielectric Antennas329
AS	Magnetic Switch362-363
B	
BL	Leaded EMIFIL® (Inductor Type)168-170
BLA	Chip Ferrite Bead (Array)142-143
BLM	Chip Ferrite Bead129-142
BNX	Block Type EMIFIL® (LC Combined)177-178
BS	Magnetic Pattern Recognition Sensors362
C	
CDALF	Ceramic Discriminators for FM277
CDBKB	Chip Ceramic Discriminators for IF312-313, 315
CDBLA	Ceramic Discriminators for IF312-314
CDBLB	Ceramic Discriminators for IF311-314
CDSCB	Chip Ceramic Discriminators for FM277
CDSCB	Chip Ceramic Discriminators for IF310-311
CE	Isolators321-322
CFUK	Chip Ceramic Filters (CERAFIL®) for IF299-302
CFULA450	Ceramic Filters (CERAFIL®) for AM269-270
CFULA455	Ceramic Filters (CERAFIL®) for IF299, 304, 306-307
CFULB	Ceramic Filters (CERAFIL®) for IF299, 305, 308
CFWKA	Chip Ceramic Filters (CERAFIL®) for IF299, 302-303
CFWLA450	Ceramic Filters (CERAFIL®) for AM269-270
CFWLA455	Ceramic Filters (CERAFIL®) for IF299, 304-305, 307
CFWLB	Ceramic Filters (CERAFIL®) for IF299, 306, 308-309
CLB	High Frequency Single Layer Microchip Capacitors342-344
CSAC	Chip Ceramic Resonators (CERALOCK®) MHz Type for Automotive258-259
CSAC	Chip Ceramic Resonators (CERALOCK®) MHz Type for General Usage261
CSALS	Ceramic Resonators (CERALOCK®) MHz Type for General Usage262
CSBFB	Chip Ceramic Resonators (CERALOCK®) kHz Type for General Usage262-263
CSBLA	Ceramic Resonators (CERALOCK®) kHz Type for General Usage263
CSTC	Chip Ceramic Resonators (CERALOCK®) MHz Type for General Usage259-261
CSTC	Chip Ceramic Resonators (CERALOCK®) MHz Type for Automotive257-259
CSTLS	Ceramic Resonators (CERALOCK®) MHz Type for General Usage262
D	
DE	High Voltage Ceramic Capacitors (250V-6.3kV)104-110
DE	Safety Standard Certified Ceramic Capacitors104, 110-115
DFC	Microwave Filters (GIGAFIL®) Band Pass Filters288-289
DFY	Microwave Filters (GIGAFIL®) Duplexer286-287
DH	High Voltage Ceramic Capacitors (10k-40kV)116-118
DLM	Common Mode Choke Coil Multilayer Type163-164
DLP_DN	Common Mode Choke Coil Film Type (Array)162-163
DLP_SA	Common Mode Choke Coil Film Type160-161
DLP_SN	Common Mode Choke Coil Film Type160-161
DLW21/31	Common Mode Choke Coil Wire Wound Type164-166
DLW5A/B	Common Mode Choke Coil Wire Wound Type for Large Current166-167
DS□6N	Leaded EMIFIL® (Capacitor Type) Small Type170-172
DS□9H	Leaded EMIFIL® (Capacitor Type) Heavy-duty Type175-177
DS□9N	Leaded EMIFIL® (Capacitor Type) Standard Type173-175
DXP18B	Balun Film Type241
DXP18C	Coupler Film Type242
DXW	Balun Wire Wound Type241
E	
EA	Microwave Absorber188
ENC	Gyro Sensors360-361
ERB	Chip Monolithic Ceramic Capacitors for High Frequency26, 336-341
F	
FR	Rotary Sensors361
FS	Ferrite Core189-195
G	
GA2	Chip Monolithic Ceramic Capacitors AC250V(r.m.s.) Type26, 89

Part Number		Page
GA3	Chip Monolithic Ceramic Capacitors Safety Standard Certified	26, 89–92
GCM	Chip Monolithic Ceramic Capacitors for Automotive	26, 77–81
GCM	Chip Monolithic Ceramic Capacitors for Medium Voltage: Automotive	26, 88
GJM	Chip Monolithic Ceramic Capacitors Low Dissipation Type	26, 66–73
GMA	Chip Monolithic Ceramic Capacitors Monolithic Microchip	26, 74
GMD	Chip Monolithic Ceramic Capacitors for Bonding	26, 75–76
GNM	Chip Monolithic Ceramic Capacitors Capacitor Array	26, 58–61
GQM	Chip Monolithic Ceramic Capacitors High Frequency	26, 330–336
GR4	Chip Monolithic Ceramic Capacitors for Medium Voltage : Information Devices	26, 86–87
GR7	Chip Monolithic Ceramic Capacitors for Medium Voltage : Only for Camera Flash Circuit	26, 87
GRM	Chip Monolithic Ceramic Capacitors for Medium Voltage : Low Dissipation	26, 82–84
GRM	Chip Monolithic Ceramic Capacitors for Medium Voltage High Capacitance	26, 84–85
GRM	Chip Monolithic Ceramic Capacitors for Medium Voltage : Only for LCD Back Lighting Inverters Circuit	26, 86
GRM	Chip Monolithic Ceramic Capacitors Standard Type	26–58
I		
IM	Fresnel Lens	356–357
IRS	Pyroelectric Infrared Sensor	356
L		
LDA	Chip Multilayer Antennas	328
LDB	Chip Multilayer Hybrid Baluns	326–327
LDC	Chip Multilayer Hybrid Couplers	323–325
LDD	Hybrid Dividers	325
LDM	Chip Multilayer Hybrid Dividers	327
LFB_BA	Chip Multilayer LC Filters (Balance Filters)	295–296
LFB_BB	Chip Multilayer LC Filters (Balance Filters)	296
LFB_CB	Chip Multilayer LC Filters (BPF)	289
LFB_SG	Chip Multilayer LC Filters (BPF)	290–293
LFB_SP	Chip Multilayer LC Filters (BPF)	293
LFD	Chip Multilayer Diplexers	326
LFL	Chip Multilayer LC Filters Low Pass Filter for RF/Local	294–295
LLA	Chip Monolithic Ceramic Capacitors Eight Terminals Low ESL	26, 64–65
LLL	Chip Monolithic Ceramic Capacitors Reversed Geometry Low ESL	26, 61–63
LLM	Chip Monolithic Ceramic Capacitors Ten Terminals Low ESL	26, 65–66
LQG	Chip Inductor (Chip Coil) for High Frequency Multilayer Type	200, 211–214
LQH	Chip Inductor (Chip Coil) for Choke Wire Wound Type	200, 235–237
LQH	Chip Inductor (Chip Coil) for General Use Wire Wound Type	200, 223–227
LQH	Chip Inductor (Chip Coil) for DC-DC Converter Wire Wound Type	200, 229–232
LQH	Chip Inductor (Chip Coil) for Choke Large Current Type	200, 239–240
LQH	Chip Inductor (Chip Coil) for High Frequency Vertical Wire Wound Ferrite Type	200, 210–211
LQM	Chip Inductor (Chip Coil) for Choke Multilayer Type	200, 237–239
LQM	Chip Inductor (Chip Coil) for DC-DC Converter Multilayer Type	200, 233–235
LQM	Chip Inductor (Chip Coil) for General Use Multilayer Type	200, 227–228
LQP	Chip Inductor (Chip Coil) for High Frequency Film Type	200, 214–222
LQW	Chip Inductor (Chip Coil) for High Frequency Vertical Wire Wound	200, 208–209
LQW	Chip Inductor (Chip Coil) for High Frequency Horizontal Wire Wound	200–207
LQW	Chip Inductor (Chip Coil) for High Frequency Horizontal Wire Wound Ferrite type	200, 210
M		
MA	Ultrasonic Sensors	357–359
MEV	Gyro Sensors	360–361
MHM	Ionizer Modules (Ionissimo™)	389
MHR	High Voltage Resistors	245
MKFCC	Ceramic Filters (BGS Filters) for IF	315
MM	Receptacle Used on Coaxial Connectors	346–347
MP	Power Supplies	384–385
MPD	DC-DC Converters	385–388
MX	Coaxial Connectors Cables	346
MYF	DC-DC Converters	387
MYS	DC-DC Converters	387
MYU	DC-DC Converters	385, 387
N		
NCP	Chip NTC for Temperature Sensor and Compensation	377–381
NFA	EMIFIL® (Capacitor Type) Array	149
NFA	EMIFIL® (RC Combined) Array	159
NFA	EMIFIL® (LC Combined) Array	154–157

Part Number		Page
NFE	EMIFIL® (LC Combined) Feed Through Type	150–151
NFL	EMIFIL® (LC Combined) Multilayer Type	152–153
NFM	EMIFIL® (Capacitor Type) Single Circuit Type for Signal Lines	144–146
NFN	EMIFIL® (Capacitor Type) Single Circuit Type for Large Current	146–148
NFR	EMIFIL® (RC Combined)	158
NFW	EMIFIL® (LC Combined) Wire Wound Type	151
NTPA	NTC Thermistors for Inrush Current Suppression	381–382

P

PKB	Piezoelectric Buzzers	397
PKGS	Shock Sensors	360
PKLCS	SMD Piezoelectric Sounders	395
PKM	Piezoelectric Ringers (PIEZORINGER®)	396
PKM	Piezoelectric Sounders	393–395
PLA	AC Line Common Mode Choke Coil	181–183
PLH	AC Line Common Mode Choke Coil	183–184
PLT	Common Mode Choke Coil for DC	179
PLY	AC Line Hybrid Choke Coils	184–188
PPGI	Fresnel Lens	357
PRF	Chip PTC Thermistors (POSISTOR®) for Overheat Sensing	354–355, 374–375
PRG	Chip PTC Thermistors (POSISTOR®) for Circuit Protection	368–369
PTF	PTC Thermistors (POSISTOR®) for Overheat Sensing	355–356, 375–376
PTGL	PTC Thermistors (POSISTOR®) for Circuit Protection	369–373
PTGL	PTC Thermistors (POSISTOR®) for Circuit Protection Narrow Current Band	369–370
PTH7M	PTC Thermistors (POSISTOR®) for Motor Starters	376
PTH8M	PTC Thermistors (POSISTOR®) for Motor Starters	377
PTWSB	PTC Thermistors (POSISTOR®) for Heater	368
PTWTA	PTC Thermistors (POSISTOR®) for Heater	368
PV12	Trimmer Potentiometers Lead Sealed Type Multi-turns	251–252
PV32	Trimmer Potentiometers Lead Sealed Type Single-turn	250–251
PV36	Trimmer Potentiometers Lead Sealed Type Multi-turns	252–253
PV37	Trimmer Potentiometers Lead Sealed Type Multi-turns	253–254
PVA2	Trimmer Potentiometers SMD Open Type 2mm Size	247
PVF2	Trimmer Potentiometers SMD Sealed Type 2mm Size	248
PVG3	Trimmer Potentiometers SMD Sealed Type 3mm Size	249
PVG5	Trimmer Potentiometers SMD Sealed Type Multi-turns	250
PVM4	Trimmer Potentiometers SMD Sealed Type 4mm Size	249–250
PVZ2	Trimmer Potentiometers SMD Open Type 2mm Size	246–247
PVZ3	Trimmer Potentiometers SMD Open Type 3mm Size	247–248

R

RDE	Monolithic Ceramic Capacitors Lead Type (Only for Commercial Use) (DC250V-DC630V)	102–103
RG	R Networks	245–246
RH	Monolithic Ceramic Capacitors Lead Type 150°C max. (for Automotive) (DC50V-DC100V)	100–102
RPE	Monolithic Ceramic Capacitors Lead Type (DC25V-DC100V)	93–99
RPE	Monolithic Ceramic Capacitors Lead Type (DC50V)	100
RUCYT	Thin Film Circuit Substrate (RUSUB®)	345

S

SAE	SAW Traps	280
SAF	SAW Filters for RF/Local	296–298
SAW	SAW Filters for RF/Local	297
SAY	SAW Duplexers	287–288
SFECF	Chip Ceramic Filters (CERAFIL®) for FM	270–271
SFECF	Chip Ceramic Filters (CERAFIL®) for IF	309–310
SFECK	Chip Ceramic Filters (CERAFIL®) for FM	272
SFECV	Chip Ceramic Filters (CERAFIL®) for FM	272
SFELF	Ceramic Filters (CERAFIL®) for FM	273–276
SFELG	Ceramic Filters (CERAFIL®) for FM	274
SFKLF	Ceramic Filters (CERAFIL®) for FM	275–276
SFPKA450	Chip Ceramic Filters (CERAFIL®) for AM	268
SFPKA455	Chip Ceramic Filters (CERAFIL®) for IF	299–300
SFPLA	Ceramic Filters (CERAFIL®) for AM	269–270
SFSCE	Chip Ceramic Filters (CERAFIL®) for IF	303
SFSKA	Chip Ceramic Filters (CERAFIL®) for TV/VCR	278
SFSKB	Chip Ceramic Filters (CERAFIL®) for TV/VCR	278
SFULA	Ceramic Filters (CERAFIL®) for AM	268
SFVLF	Ceramic Filters (CERAFIL®) for FM	276

Part Number		Page
SFZLA	Ceramic Filters (CERAFIL®) for AM.....	268
SV	Rotary Position Sensors.....	361
T		
TPSKA	Chip Ceramic Traps.....	279
TPWKA	Chip Ceramic Traps (Double Traps).....	279
TZR1	Trimmer Capacitors SMD Type 1mm Size.....	119
TZS2	Trimmer Capacitors SMD Type 2mm Size.....	119
TZY2	Trimmer Capacitors SMD Type 2mm Size.....	119-120
TZV2	Trimmer Capacitors SMD Type 2mm Size.....	119-120
TZC3	Trimmer Capacitors SMD Type 3mm Size.....	120
TZB4	Trimmer Capacitors SMD/Lead Type 4mm Size.....	121
TZ03	Trimmer Capacitors Lead Type 6mm Size.....	122
TZW4	Trimmer Capacitors SMD Type 4mm Size High-Q & High Power Type.....	121-122
V		
VFR	EMIGUARD® (EMIFIL® with Varistor Function).....	179
VFS	EMIGUARD® (EMIFIL® with Varistor Function).....	180
X		
XRCGA	Crystal Resonators.....	257
7□B		
7□B	Piezoelectric Diaphragms.....	398

Murata's website plays a vital role in solving your problems.

<http://www.murata.com/>



Murata's website puts a rich source of information and resources for design issues at your fingertips. From recommending parts for circuits and providing application information about parts, to introducing solutions to the problem of EMI, we provide a broad spectrum of support concerning design work. Electronic parts are a core part of what we do - so, as a parts user, when you need a "partner", this is the place to come!

△Note • This PDF catalog is downloaded from the website of Murata Manufacturing Co., Ltd. Therefore, its specifications are subject to change or our products in it may be discontinued without advance notice. Please check with our sales representatives or product engineers before ordering.
• This PDF catalog has only typical specifications because there is no space for detailed specifications. Therefore, please approve our product specifications or transact the approval sheet for product specifications before ordering.

⚠ Note:**1. Export Control**

<For customers outside Japan>

No Murata products should be used or sold, through any channels, for use in the design, development, production, utilization, maintenance or operation of, or otherwise contribution to (1) any weapons (Weapons of Mass Destruction [nuclear, chemical or biological weapons or missiles] or conventional weapons) or (2) goods or systems specially designed or intended for military end-use or utilization by military end-users.

<For customers in Japan>

For products which are controlled items subject to the "Foreign Exchange and Foreign Trade Law" of Japan, the export license specified by the law is required for export.

2. Please contact our sales representatives or product engineers before using the products in this catalog for the applications listed below, which require especially high reliability for the prevention of defects which might directly damage a third party's life, body or property, or when one of our products is intended for use in applications other than those specified in this catalog.

- | | |
|-----------------------------|--|
| ① Aircraft equipment | ② Aerospace equipment |
| ③ Undersea equipment | ④ Power plant equipment |
| ⑤ Medical equipment | ⑥ Transportation equipment (vehicles, trains, ships, etc.) |
| ⑦ Traffic signal equipment | ⑧ Disaster prevention / crime prevention equipment |
| ⑨ Data-processing equipment | ⑩ Application of similar complexity and/or reliability requirements to the applications listed above |

3. Product specifications in this catalog are as of July 2009. They are subject to change or our products in it may be discontinued without advance notice. Please check with our sales representatives or product engineers before ordering. If there are any questions, please contact our sales representatives or product engineers.

4. This catalog has only typical specifications because there is no space for detailed specifications. Therefore, please approve our product specifications or transact the approval sheet for product specifications before ordering. Especially, please read rating and ⚠ CAUTION (for storage, operating, rating, soldering, mounting and handling) in them to prevent smoking and/or burning, etc.

5. You are able to read a detailed specification in the website of Search Engine (<http://search.murata.co.jp/>) or catalog library (<http://www.murata.com/catalog/>) before to require our product specification or to transact the approval sheet for product specification.

6. Please note that unless otherwise specified, we shall assume no responsibility whatsoever for any conflict or dispute that may occur in connection with the effect of our and/or a third party's intellectual property rights and other related rights in consideration of your use of our products and/or information described or contained in our catalogs. In this connection, no representation shall be made to the effect that any third parties are authorized to use the rights mentioned above under licenses without our consent.

7. No ozone depleting substances (ODS) under the Montreal Protocol are used in our manufacturing process.

***muRata* Murata Manufacturing Co., Ltd.**

<http://www.murata.com/>

Head Office
1-10-1, Higashi Kotari, Nagaokakyo-shi, Kyoto 617-8555, Japan
Phone: 81-75-951-9111

International Division
3-29-12, Shibuya, Shibuya-ku, Tokyo 150-0002, Japan
Phone: 81-3-5469-6123 Fax: 81-3-5469-6155 E-mail: intl@murata.co.jp

Cat. No. K99E-27

⚠ Note • This PDF catalog is downloaded from the website of Murata Manufacturing co., Ltd. Therefore, it's specifications are subject to change or our products in it may be discontinued without advance notice. Please check with our sales representatives or product engineers before ordering.
• This PDF catalog has only typical specifications because there is no space for detailed specifications. Therefore, please approve our product specifications or transact the approval sheet for product specifications before ordering.