

Order code	Manufacturer code	Description
47-3478	n/a	MC34063ADG SWITCHING REGULATOR SO-8 RC

	Page 1 of 15
The enclosed information is believed to be correct, Information may change without notice due to product improvement. Users should ensure that the product is suitable for their use. E. & O. E.	Revision A 20/02/2007

Application of the MC34063 Switching Regulator

Shafi Sekander and Mahmoud Harmouch

SLL Linear

ABSTRACT

This application report provides the features that are necessary to implement dc-to-dc fixed-frequency schemes with a minimum number of external components using the MC34063. This device represents significant advancements in ease of use with highly efficient and, yet, simple switching regulators. The use of switching regulator is becoming more pronounced over that of linear regulators, because of the size and power-efficiency requirement of new equipment designs. The use of switching regulators increases application flexibility and reduces the cost.

Contents

1	MC34063 Description	2
2	Functional Description	5
3	Buck Regulator.....	6
4	Boost Switching Regulator	9
5	Inverting Switching Regulator	11
6	Selecting the Right Inductor	13

List of Figures

1	Functional Block Diagram	2
2	Reference Voltage Circuit	2
3	Oscillator Voltage Thresholds.....	3
4	Timing Capacitor Charge Current vs Current-Limit Sense Voltage.....	3
5	Typical Operation Waveforms	4
6	Buck Regulator.....	6
7	Buck Switching Regulator Waveforms.....	8
8	Boost Switching Regulator	9
9	Boost Switching Regulator Waveforms	11
10	Switching Inverter Regulator.....	11
11	Inverter Switching Regulator Waveforms	12

List of Tables

1	Logic Truth Table of Functional Blocks	5
---	--	---

1 MC34063 Description

The MC34063 is a monolithic control circuit containing all the active functions required for switching dc-to-dc converters (see Figure 1). The MC34063 includes the following components:

- Temperature-compensated reference voltage
- Oscillator
- Active peak-current limit
- Output switch
- Output voltage-sense comparator

The MC34063 was designed to be incorporated in buck, boost, or voltage-inverter converter applications. All these functions are contained in an 8-pin DIP or SOIC package.

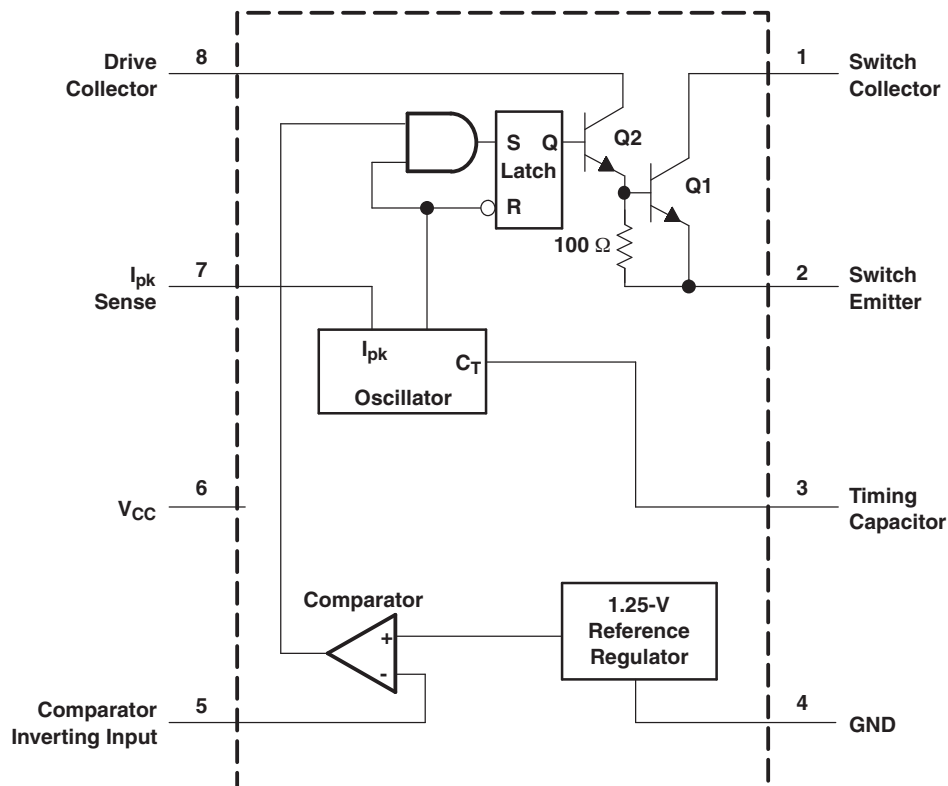

Figure 1. Functional Block Diagram

1.1 Reference Voltage

The reference voltage is set at 1.25 V and is used to set the output voltage of the converter.

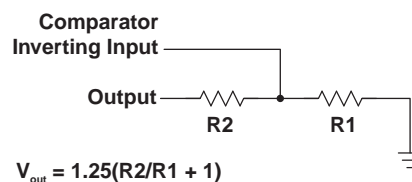

Figure 2. Reference Voltage Circuit

1.2 Oscillator

The oscillator is composed of a current source and a current sink that charge and discharge the external timing capacitor (C_T) between an upper and lower preset threshold. The typical charge current is $35 \mu\text{A}$, and the typical discharge current is $200 \mu\text{A}$, yielding approximately a 6:1 ratio. Thus, the ramp-up period is six times longer than that of the ramp-down period (see Figure 3).

The upper threshold is 1.25 V , which is same as the internal reference voltage, and the lower threshold is 0.75 V . The oscillator runs constantly, at a pace controlled by the value of C_T .

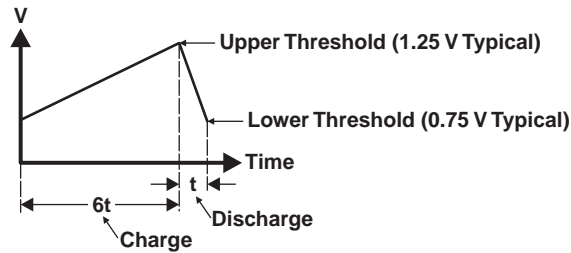

Figure 3. Oscillator Voltage Thresholds

1.3 Current Limit

Current limit is accomplished by monitoring the voltage drop across an external sense resistor located in series with V_{CC} and the output switch. The voltage drop developed across the sense resistor is monitored by the current-sense pin, I_{pk} . When the voltage drop across the sense resistor becomes greater than the preset value of 330 mV , the current-limit circuitry provides an additional current path to charge the timing capacitor (C_T) rapidly, to reach the upper oscillator threshold and, thus, limiting the amount of energy stored in the inductor. The minimum sense resistor is 0.2Ω . Figure 4 shows the timing capacitor charge current versus current-limit sense voltage. To set the peak current, $I_{pk} = 330 \text{ mV}/R_{sense}$.

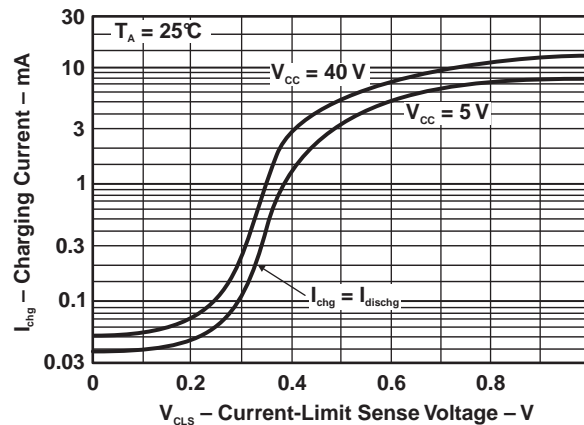

Figure 4. Timing Capacitor Charge Current vs Current-Limit Sense Voltage

1.4 Output Switch

The output switch is an NPN Darlington transistor. The collector of the output transistor is tied to pin 1, and the emitter is tied to pin 2. This allows the designer to use the MC34063 in buck, boost, or inverter configurations. The maximum collector-emitter saturation voltage at 1.5 A (peak) is 1.3 V, and the maximum peak current of the output switch is 1.5 A. For higher peak output current, an external transistor can be used. Figure 5 shows the typical operation waveforms.

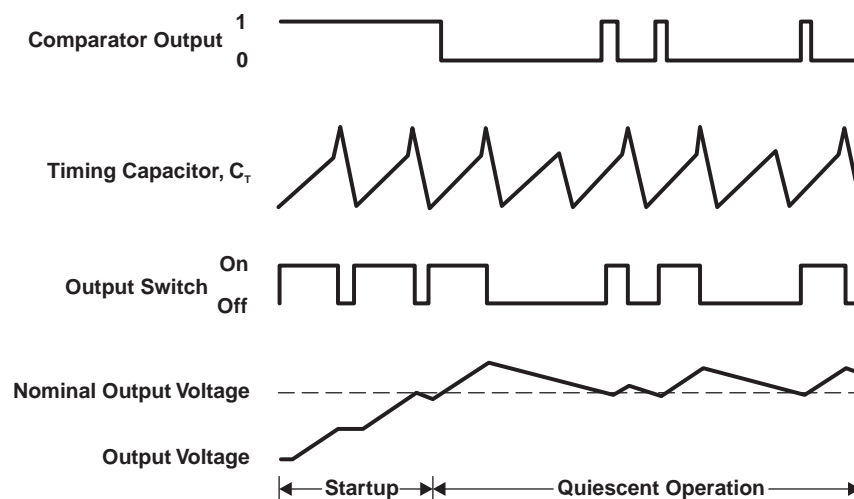







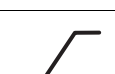



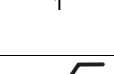

Figure 5. Typical Operation Waveforms

2 Functional Description

The oscillator is composed of a current source and sink, which charge and discharge the external timing capacitor (C_T) between an upper and lower preset threshold. The typical charge and discharge currents are 35 mA and 200 mA, respectively, yielding approximately a 6:1 ratio. Thus, the ramp-up period is six times longer than that of the ramp-down period (see Figure 3). The upper threshold is equal to internal reference voltage of 1.25 V, and the lower threshold is approximately equal to 0.75 V. The oscillator runs continuously at a rate controlled by the value of C_T .

During the ramp-up portion of the cycle, a logic 1 is present at the A input of the AND gate. If the output voltage of the switching regulator is below nominal, a logic 1 is also present at the B input. This condition sets the latch and causes the Q output to be a logic 1, enabling the driver and output switch to conduct. When the oscillator reaches its upper threshold, C_T starts to discharge, and a logic 0 is present at the A input of the AND gate. This logic level is also connected to an inverter whose output presents a logic 1 to the reset input of the latch. This condition causes Q to go low, disabling the driver and output switch. A logic truth table of these functional blocks is shown in Table 1.

Table 1. Logic Truth Table of Functional Blocks

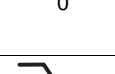
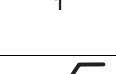
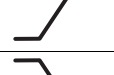
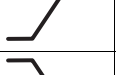
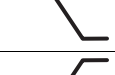
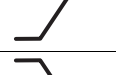
Active Condition of Timing Capacitor, C_T	AND Gate Inputs		Latch Inputs		Output Switch	Comments
	A	B	S	R		
Begin ramp up		0	0		0	Regulator output is greater than or equal to nominal ($B = 0$).
Begin ramp down		0	0		0	No change, because B was 0 before C_T ramp down.
Ramping down	0		0	1	0	No change even though regulator output less than nominal. Output switch cannot be initiated during R_T ramp down.
Ramping down	0		0	1	0	No change, because output switch condition was terminated when $A = 0$.
Ramping up	1			0		Regulator output became less than nominal during C_T ramp up (when B changed to 1). Partial on cycle for output switch.
Ramping up	1			0	1	Regulator output became greater than or equal to nominal (B changed to 0) during ramp up of C_T . No change, because B cannot reset the latch.
Begin ramp up		1				Complete on cycle, because $B = 1$ before C_T ramp up started.
Begin ramp down		1				Output switch conduction is always terminated when C_T is ramping down.

The output of the comparator can set the latch only during the ramp up of C_T and can initiate a partial or full on cycle of output switch conduction. Once the comparator has set the latch, it cannot reset it. The latch remains set until C_T begins ramping down. Thus, the comparator can initiate output switch conduction but cannot terminate it, and the latch is always reset when C_T begins ramping down. The comparator's output is at a logic 0 when the output voltage of the switching regulator is above nominal. Under these conditions, the comparator's output can inhibit a portion of the output switch on cycle, a complete cycle, a complete cycle plus a portion of one cycle, multiple cycle, or multiple cycles plus a portion of one cycle.

3 Buck Regulator

Figure 6 shows the basic buck switching regulator. Q1 interrupts the input voltage and provides a variable duty-cycle square wave to an LC filter. The filter averages the square wave and produces a dc output voltage that can be set to any level less than the input by controlling the percent conduction time of Q1 to that of the total switching cycle time.

$$V_{out} = V_{in}(\%t_{on})$$

or

$$V_{out} = V_{in}(t_{on}/(t_{on} + t_{off}))$$

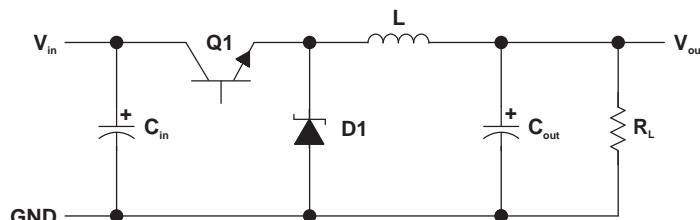

Figure 6. Buck Regulator

3.1 Buck Converter Operation

As an example, suppose that the transistor Q1 is off, the inductor current (I_L) is zero, and the output voltage is at its nominal value. The output voltage across capacitor C_{out} will ultimately decay below the nominal output level, because it is the only source of supply current to load R_L . This voltage deficiency is sensed by the switching control circuit and causes Q1 to turn on. The inductor current starts to flow from V_{in} through Q1 and C_{out} in parallel with R_L , and it rises at a rate of $\Delta I/\Delta t = V/L$. The voltage across the inductor is equal to $V_{in} - V_{sat} - V_{out}$, and the inductor peak current at any instant is calculated as shown here:

$$I_L = ((V_{in} - V_{sat} - V_{out})/L)t$$

At the end of the on period, Q1 is turned off. As the magnetic field in the inductor starts to collapse, it generates a reverse voltage that forward biases D1, and the peak current decays at a rate of $\Delta I/\Delta t = V/L$ as energy is supplied to C_{out} and R_L . The voltage across the inductor during this period is equal to $V_{out} + V_F$ of D1. The current as a function of time is calculated as shown here:

$$I_L = I_{L(pk)} - ((V_{out} + V_F)/L)t$$

Where V_F is the forward voltage of D1.

3.2 Time-On and Time-Off Calculation

As an example, suppose that during quiescent operation, the average output voltage is constant, and the system is operating in the discontinuous mode. Then $I_{L(pk)}$ attained during t_{on} must decay to zero during t_{off} , and a ratio of t_{on} to t_{off} can be determined.

$$\begin{aligned} ((V_{in} - V_{sat} - V_{out})/L)t_{on} &= ((V_{out} + V_F)/L)t_{off} \\ \therefore t_{on}/t_{off} &= (V_{out} + V_F)/(V_{in} - V_{sat} - V_{out}) \end{aligned}$$

3.3 Switch Peak Current Calculation

The volt-time product of t_{on} must be equal to that of t_{off} , and the inductance value is not a factor when determining their ratio. If the output voltage inside a switching period is to remain constant, the average current into the inductor must be equal to the output current for a complete cycle. The peak inductor current with respect to output current is:

$$\begin{aligned} (I_{L(pk)}/2)t_{on} + (I_{L(pk)}/2)t_{off} &= I_{out}t_{on} + I_{out}t_{off} \\ \therefore I_{L(pk)} &= 2I_{out} \end{aligned}$$

3.4 Timing Capacitor Calculation

The peak inductor current is also equal to the peak switch current, since the two are in series. The on time (t_{on}) is the maximum possible switch conduction time. It is equal to the time required for C_T to ramp up from its lower to upper threshold. The required value for C_T can be determined by using the minimum oscillator charging current and the typical value for the peak-to-peak oscillator voltage swing, both taken from the data sheet.

$$C_T = I_{chg(min)}(\Delta t/\Delta V)$$

$$C_T = 20 \times 10^{-6}(t_{on}/0.5)$$

$$C_T = 4.0 \times 10^{-5}(t_{on})$$

The off time is the time that diode D1 is in conduction and it is determined by the time required for the inductor current to return to zero. The off time is not related to the ramp-down time of C_T . The cycle time of the LC network is equal to $t_{on(max)} + t_{off}$, and the minimum operation frequency is calculated as shown here:

$$f_{min} = 1/(t_{on(max)} + t_{off})$$

3.5 Inductance Calculation

The minimum value of inductance (L) can now be calculated. The V-known quantities are the voltage across the inductor and the required peak current for the selected switch conduction time:

$$L_{min} = ((V_{in} - V_{sat} - V_{out})/I_{pk(switch)})t_{on}$$

The minimum value of inductance is calculated assuming the onset of continuous conduction operation with a fixed input voltage, maximum output current, and a minimum charge-current oscillator.

The net charge per cycle delivered to output filter capacitor (C_{out}) must be zero ($Q+ = Q-$) if the output voltage is to remain constant.

3.6 Output Voltage Ripple

The ripple voltage can be calculated from the known values of on time, off time, peak inductor current, and output capacitor value:

During t_{on}

$$i_c(t) = I_{pk}/t_{on} \times t, \text{ positive slope}$$

$$V(t) = 1/C_{out} \int I_{pk}/t_{on} \times t \, dt$$

$$= I_{pk}/(C_{out} \times t_{on}) \times t^2/2 + \text{constant}$$

The axis of the parabola pass was chosen by its minimum, so constant = 0.

$$= I_{pk}/(C_{out} \times t_{on}) \times t^2/2$$

$$V(t_{on}/2) = I_{pk}/(C_{out} \times t_{on}) \times (t_{on}/2)^2/2$$

$$= I_{pk}/C_{out} \times t_{on}/8$$

During t_{off}

$$i_c(t) = -I_{pk}/t_{off} \times t, \text{ negative slope}$$

$$V(t) = -1/C_{out} \int I_{pk}/t_{off} \times t \, dt$$

$$= -I_{pk}/(C_{out} \times t_{off}) \times t^2/2 + \text{constant}$$

The axis of the parabola pass was chosen by its minimum, so constant = 0.

$$= -I_{pk}/(C_{out} \times t_{off}) \times t^2/2$$

$$V(t_{off}/2) = -I_{pk}/(C_{out} \times t_{off}) \times (t_{off}/2)^2/2$$

$$= -I_{pk}/C_{out} \times t_{off}/8$$

$$V_{ripple(C)} = |V(t_{on}/2)| + |V(t_{off}/2)|$$

$$= (I_{pk}/C_{out}) \times (t_{on}/8) + (I_{pk}/C_{out}) \times (t_{off}/8)$$

$$V_{\text{ripple}(C)} = (I_{\text{pk}}/C_{\text{out}}) \times (t_{\text{on}} + t_{\text{off}})/8$$

$$V_{\text{ripple}(ESR)} = I_{\text{pk}} \times \text{ESR}$$

$$V_{\text{ripple}(p-p)} = I_{\text{pk}}/C_{\text{out}} \times (t_{\text{on}} + t_{\text{off}}) + I_{\text{pk}} \times \text{ESR}$$

$$V_{\text{ripple}(p-p)} = I_{\text{pk}} \times [(1/8C) \times (t_{\text{on}} + t_{\text{off}}) + \text{ESR}]$$

Figure 7 shows a graphical derivation of the peak-to-peak ripple voltage that was obtained from the capacitor current and voltage waveforms.

The calculations shown above account for the ripple voltage contributed by the ripple current into an ideal capacitor.

In practice, the calculated value should be increased due to the internal equivalent series resistance (ESR) of the capacitor. The additional ripple voltage is equal to $I_{\text{pk}}(\text{ESR})$. Increasing the value of the filter capacitor reduces the output ripple voltage. However, a point of diminishing return is reached, because the comparator requires a finite voltage difference across its inputs to control the latch. The voltage difference required to completely change the latch states is about 1.5 mV, and the minimum achievable ripple at the output is the feedback divider ratio multiplied by 1.5 mV:

$$V_{\text{ripple}(p-p)}(\text{min}) = (V_{\text{out}}/V_{\text{ref}})(1.5 \times 10^{-3})$$

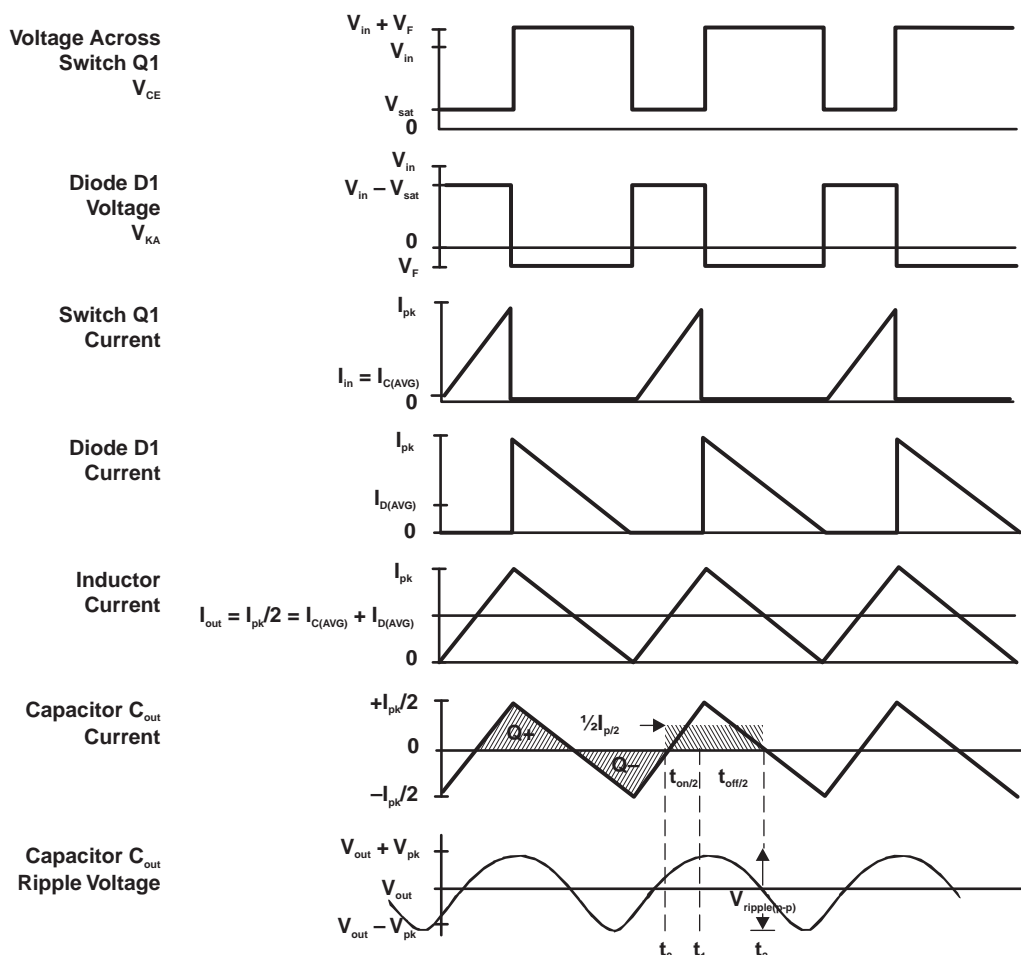

Figure 7. Buck Switching Regulator Waveforms

4 Boost Switching Regulator

Figure 8 shows a basic switching regulator. Energy is stored in the inductor during the time that transistor Q1 is in the ON state. When transistor Q1 is turned off, the energy is transferred in series with V_{in} to the output filter capacitor (C_{out}) and load (R_L). This configuration allows the output voltage to be set to any value greater than that of input. The following equations can be used to calculate the output voltage:

$$\begin{aligned}
 V_{out} &= V_{in}(t_{on}/t_{off}) + V_{in} \\
 \text{OR} \\
 V_{out} &= V_{in}((t_{on}/t_{off}) + 1)
 \end{aligned}$$

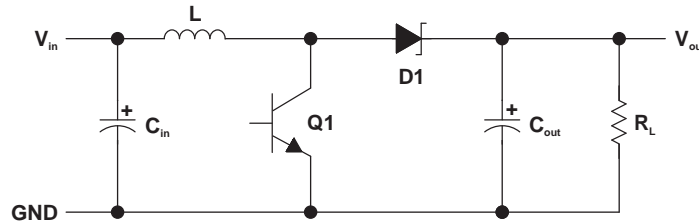

Figure 8. Boost Switching Regulator

4.1 Operation of MC34063 as Boost Converter

As an example, suppose that transistor Q1 is off, the inductor current is zero, and output voltage is at its nominal value. At this time, load current is being supplied only by C_{out} , and it will eventually fall below nominal value. When the output voltage falls below the nominal value, it is sensed by the control circuit, which initiates an on cycle, driving transistor Q1 into saturation. Current starts to flow from input through the inductor and Q1, and it rises at a rate of $\Delta I/\Delta t = V/L$. The voltage across the inductor is equal to $V_{in} - V_{sat}$, and the peak current is roughly a linear function of t , as shown here:

$$I_L = ((V_{in} - V_{sat})/L)t$$

When the on-time is completed, Q1 turns off, and the magnetic field in the inductor starts to collapse, generating a reverse voltage that forward biases D1, supplying energy to C_{out} and R_L . The inductor current decays at rate of $\Delta I/\Delta t = V/L$, and the voltage across it is equal to $V_{out} + V_F - V_{in}$. The current at any instant is calculated as shown here:

$$I_L = I_{L(pk)} - ((V_{out} + V_F - V_{in})/L)t$$

4.2 Time-On and Time-Off Calculation

Assuming that the system is operating in the discontinuous mode, the current through the inductor reaches zero after the t_{off} period is completed. Then the $I_{L(pk)}$ attained during t_{on} must decay to zero during t_{off} , and a ratio of t_{on} to t_{off} can be written as shown here:

$$\begin{aligned}
 ((V_{in} - V_{sat})/L)t_{on} &= ((V_{out} + V_F - V_{in})/L)t_{off} \\
 \therefore t_{on}/t_{off} &= (V_{out} + V_F - V_{in})/(V_{in} - V_{sat})
 \end{aligned}$$

The volt-time product of t_{on} must be equal to that of t_{off} , and the inductance value does not affect this relationship.

The inductor current charges the output filter capacitor through D1 during t_{off} . If the output voltage is to remain constant, the net charge per cycle delivered to output filter capacitor must be zero ($Q_+ = Q_-$).

$$I_{chg}t_{off} = I_{dischg}t_{on}$$

4.3 Peak Current Calculation

Figure 9 shows the boost switching regulator waveforms. By observing the capacitor current and making some substitution in the previous equation, a formula for peak inductor current can be obtained.

$$\begin{aligned}
 (I_{L(pk)}/2)t_{off} &= I_{out}(t_{on} + t_{off}) \\
 \therefore I_{L(pk)} &= 2I_{out}(t_{on}/t_{off} + 1)
 \end{aligned}$$

4.4 Inductance Calculation

The peak inductor current is also equal to the peak switch current, since the two are in series. By knowing the voltage across the inductor during t_{on} and the required peak current for the selected switch conduction time, a minimum inductance value can be determined:

$$L_{min} = ((V_{in} - V_{sat})/I_{pk(switch)})t_{on(max)}$$

4.5 Output Voltage Ripple

Calculate the output ripple voltage from the known values of t_{on} , t_{off} , peak inductor current, output current, and output capacitor value. The capacitor current waveforms is depicted in [Figure 9](#), t_1 being the discharging interval. Solving for t_1 in known terms yields:

During t_{off} , the current is linear with negative slope, $-\Delta I_L/t_{off}$

$$i_c(t) = -(I_{pk}/t_{off}) \times t$$

$$V(t) = -1/C_{out} \int (I_{pk}/t_{off}) \times t \, dt$$

$$= -I_{pk}/(C_{out} \times t_{off}) \times t^2/2 + \text{constant}$$

The axis of the parabol pass was chosen by the maximum so constant = 0.

$$= -I_{pk}/(C_{out} \times t_{off}) \times t^2/2$$

$$V(-\tau) = -I_{pk}/(C_{out} \times t_{off}) \times \tau^2/2, \tau \text{ is time from } i_c(t) = \text{max to } i_c(t) = 0$$

$$(t_{off} - \tau)/_{off} = I_{out}/I_{pk}, \text{ triangle geometry}$$

$$\tau = t_{off} \times (I_{pk} - I_0)/I_{pk} \quad (1)$$

$$V(-\tau) = -I_{pk}/2(C_{out} \times t_{off}) \times (t_{off})^2 \times (I_{pk} - I_0)^2/\Delta I_L^2$$

$$V(-\tau) = -t_{off} \times (I_{pk} - I_0)^2/(2C_{out} \times I_{pk}) \quad (2)$$

Energy conservation in the output capacitor: $Q_+ = Q_-$

$$(I_{pk} - I_0) \times \tau/2 = (t_{off} - \tau) \times I_0/2 + I_0 \times t_{on} \quad (3)$$

Equation 1 and Equation 2 give:

$$\begin{aligned} t_{off} \times (I_{pk} - I_0)^2/2\Delta I_L &= I_0/2 \times t_{off} \times (1 - (\Delta I_L - I_0)/\Delta I_L) + I_0 \times t_{on} \\ &= t_{off} \times I_0^2/2\Delta I_L + I_0 \times t_{on} \end{aligned}$$

$$t_{off} \times ((I_{pk} - I_0)^2 - I_0^2)/2I_{pk} = I_0 \times t_{on}$$

$$(I_{pk} - 2I_0) \times t_{off}/2 = I_0 \times t_{on}$$

The inductor ripple current:

$$I_{pk} = 2I_{out} \times (1 + t_{on}/t_{off}) \quad (4)$$

From output capacitor ripple periodicity and continuity:

$$V(-\tau) = V_{ripple(pp)}$$

By substituting Equation 4 in Equation 3:

$$V_{ripple}(C_{out}) = I_{out}(t_{off} + 2t_{on})^2/2C(t_{off} + t_{on})$$

If $t_{on} = 6.5t_{off}$, then:

$$V_{ripple}(ESR) = 2I_{out} \times (1 + t_{on}/t_{off}) \times ESR$$

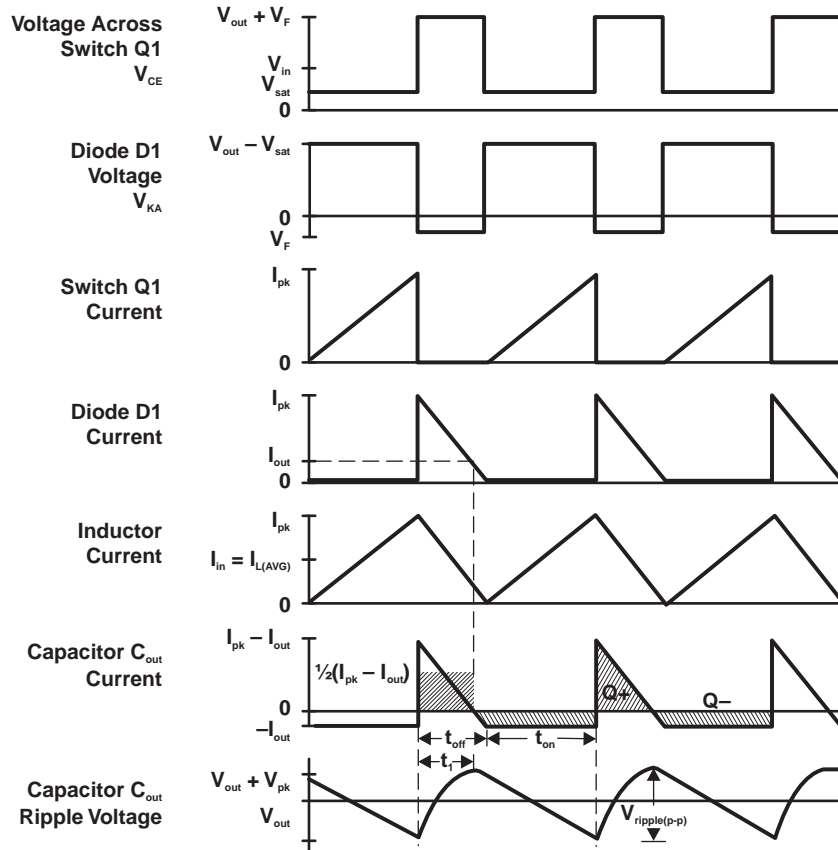

Figure 9. Boost Switching Regulator Waveforms

5 Inverting Switching Regulator

A basic voltage-inverting switching regulator is shown in Figure 10. The energy is stored in the inductor during the conduction time of Q1. Upon the Q1 turn off, the energy is transferred to the output filter capacitor and load. In this configuration, the output voltage is derived only from the inductor. This allows the magnitude of the output to be set to any value. It may be less than, equal to, or greater than that of the input and is set by the following:

$$V_{out} = V_{in}(t_{on}/t_{off})$$

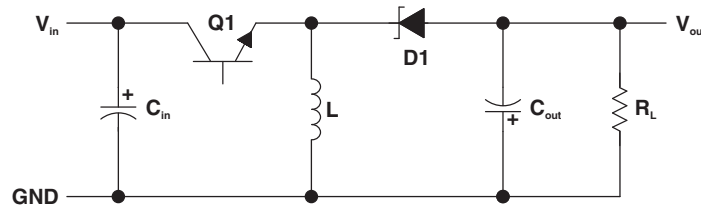

Figure 10. Switching Inverter Regulator

The inverter converter operates identically to that of the boost converter. The voltage across the inductor during t_{on} is $V_{in} - V_{sat}$ but, during t_{off} , the voltage is equal to the negative magnitude of $V_{out} + V_F$. The VLT time-product of t_{on} must be equal to that of t_{off} , a ratio of t_{on} to t_{off} can be determined:

$$(V_{in} - V_{sat})t_{on} = (|V_{out}| + V_F)t_{off}$$

$$\therefore t_{on}/t_{off} = (|V_{out}| + V_F)/(V_{in} - V_{sat})$$

The derivations and the formulas for $I_{pk(switch)}$, $L_{(min)}$, and C_{out} are the same as that of the boost converter. Figure 11 shows the voltage-inverter switching regulator waveforms.

Inverting Switching Regulator

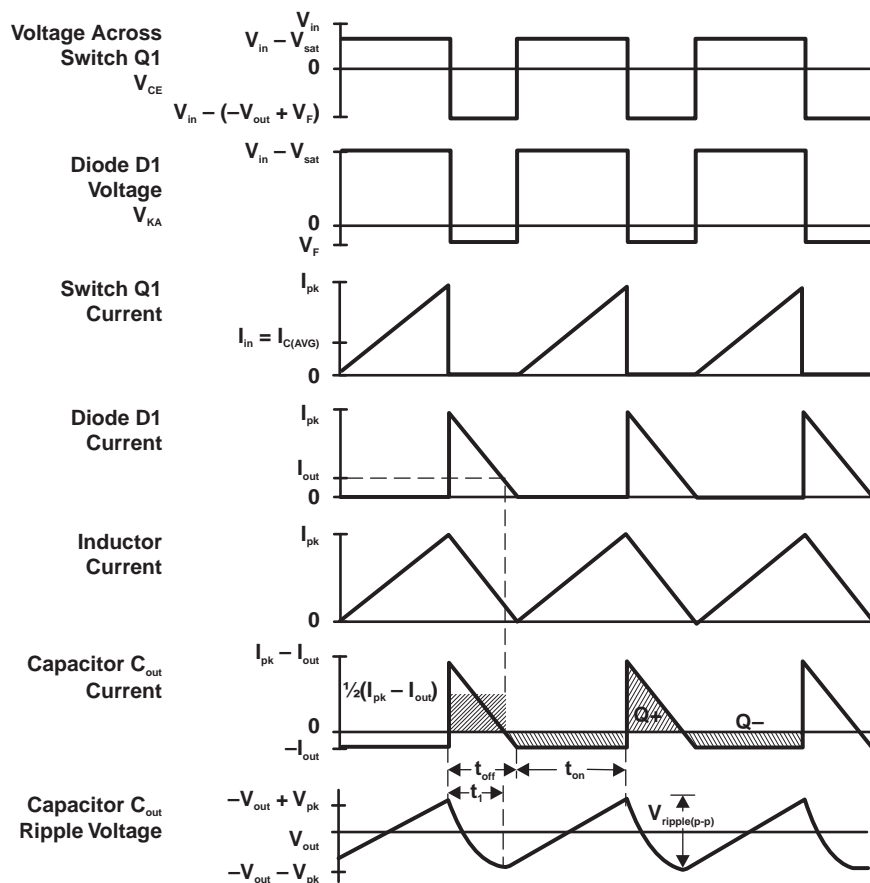

Figure 11. Inverting Switching Regulator Waveforms

6 Selecting the Right Inductor

Proper inductor selection is crucial to the performance of the switching regulator's design. The switching regulator has two mode of operation:

- Continuous mode
- Discontinuous mode

Each mode has characteristically different operating characters and, therefore, can affect the regulator performance and requirements. In many applications, the continuous mode is the preferred mode of operation, since it offers greater output power with lower peak currents, wider input range, and lower output ripple. These advantages of continuous-mode operation come at the expense of a larger inductor.

Once the minimum inductor and peak current value are determined, the inductor can be selected. Most manufacturers provide the following data in their data book:

- Inductance value
- DCR (dc resistance) of the winding
- DC saturation current
- RMS current
- Package type, size, and pattern

The geometry and the shape of the inductor chosen can have advantages and disadvantages. If high performance is a concern, then the toroid inductors are the best choices, as the magnetic flux is contained completely within the magnetic core, resulting in less EMI and noise. The EMI and noise can affect nearby sensitive circuits. In these situations, closed magnetic structures, such as toroid, pot core, or E-core, are more appropriate.

In cost-sensitive applications, the inexpensive bobbin core inductors can be used. However, the bobbin core inductors can generate more EMI, as the open core does not confine the flux within the core and can affect nearby sensitive circuits.

IMPORTANT NOTICE

Texas Instruments Incorporated and its subsidiaries (TI) reserve the right to make corrections, modifications, enhancements, improvements, and other changes to its products and services at any time and to discontinue any product or service without notice. Customers should obtain the latest relevant information before placing orders and should verify that such information is current and complete. All products are sold subject to TI's terms and conditions of sale supplied at the time of order acknowledgment.

TI warrants performance of its hardware products to the specifications applicable at the time of sale in accordance with TI's standard warranty. Testing and other quality control techniques are used to the extent TI deems necessary to support this warranty. Except where mandated by government requirements, testing of all parameters of each product is not necessarily performed.

TI assumes no liability for applications assistance or customer product design. Customers are responsible for their products and applications using TI components. To minimize the risks associated with customer products and applications, customers should provide adequate design and operating safeguards.

TI does not warrant or represent that any license, either express or implied, is granted under any TI patent right, copyright, mask work right, or other TI intellectual property right relating to any combination, machine, or process in which TI products or services are used. Information published by TI regarding third-party products or services does not constitute a license from TI to use such products or services or a warranty or endorsement thereof. Use of such information may require a license from a third party under the patents or other intellectual property of the third party, or a license from TI under the patents or other intellectual property of TI.

Reproduction of TI information in TI data books or data sheets is permissible only if reproduction is without alteration and is accompanied by all associated warranties, conditions, limitations, and notices. Reproduction of this information with alteration is an unfair and deceptive business practice. TI is not responsible or liable for such altered documentation. Information of third parties may be subject to additional restrictions.

Resale of TI products or services with statements different from or beyond the parameters stated by TI for that product or service voids all express and any implied warranties for the associated TI product or service and is an unfair and deceptive business practice. TI is not responsible or liable for any such statements.

TI products are not authorized for use in safety-critical applications (such as life support) where a failure of the TI product would reasonably be expected to cause severe personal injury or death, unless officers of the parties have executed an agreement specifically governing such use. Buyers represent that they have all necessary expertise in the safety and regulatory ramifications of their applications, and acknowledge and agree that they are solely responsible for all legal, regulatory and safety-related requirements concerning their products and any use of TI products in such safety-critical applications, notwithstanding any applications-related information or support that may be provided by TI. Further, Buyers must fully indemnify TI and its representatives against any damages arising out of the use of TI products in such safety-critical applications.

TI products are neither designed nor intended for use in military/aerospace applications or environments unless the TI products are specifically designated by TI as military-grade or "enhanced plastic." Only products designated by TI as military-grade meet military specifications. Buyers acknowledge and agree that any such use of TI products which TI has not designated as military-grade is solely at the Buyer's risk, and that they are solely responsible for compliance with all legal and regulatory requirements in connection with such use.

TI products are neither designed nor intended for use in automotive applications or environments unless the specific TI products are designated by TI as compliant with ISO/TS 16949 requirements. Buyers acknowledge and agree that, if they use any non-designated products in automotive applications, TI will not be responsible for any failure to meet such requirements.

Following are URLs where you can obtain information on other Texas Instruments products and application solutions:

Products		Applications	
Amplifiers	amplifier.ti.com	Audio	www.ti.com/audio
Data Converters	dataconverter.ti.com	Automotive	www.ti.com/automotive
DSP	dsp.ti.com	Broadband	www.ti.com/broadband
Interface	interface.ti.com	Digital Control	www.ti.com/digitalcontrol
Logic	logic.ti.com	Military	www.ti.com/military
Power Mgmt	power.ti.com	Optical Networking	www.ti.com/opticalnetwork
Microcontrollers	microcontroller.ti.com	Security	www.ti.com/security
RFID	www.ti-rfid.com	Telephony	www.ti.com/telephony
Low Power Wireless	www.ti.com/lpw	Video & Imaging	www.ti.com/video
		Wireless	www.ti.com/wireless

Mailing Address: Texas Instruments, Post Office Box 655303, Dallas, Texas 75265
Copyright © 2007, Texas Instruments Incorporated