

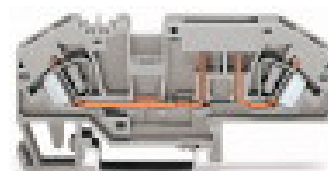

2-conductor fuse terminal block for standard automotive blade-style fuses; with test option; without blown fuse indication

Item No.: 282-696



2-conductor fuse terminal block for standard automotive blade-style fuses; with test option; without blown fuse indication

Marking

RoHS ✓
Compliant

Business data

Supplier	WAGO
Item no.	282-696
GTIN / EAN	4050821234517
Content	1

Notes

Safety information 2: Blade-style fuses: Observe touch-proof protection for 42 V and higher voltages!

Technical data

Miscellaneous

Safety information 1	Electrical ratings are given by the fuse.
Ratings per	IEC/EN 60947-7-3
Rated voltage (III / 3) [V]	400 [V]
Rated impulse voltage (III / 3) [kV]	6 [kV]
Rated current [A]	25 [A]

Technical data	
<i>Rated current (2) [A]</i>	30 [A]
<i>Legend (ratings)</i>	(III / 3) Overvoltage category III / Pollution degree 3
<i>Connection technology</i>	CAGE CLAMP®
<i>Actuation type</i>	Operating tool
<i>Connectable conductor materials</i>	Copper
<i>Solid conductor</i>	0.2 ... 6 mm ² / 24 ... 10 AWG
<i>Fine-stranded conductor</i>	0.2 ... 6 mm ² / 24 ... 10 AWG
<i>Strip length</i>	12 ... 13 mm / 0.47 ... 0.51 Inch
<i>Total number of connection points</i>	2
<i>Total number of potentials</i>	2
<i>Number of levels</i>	1
<i>Type of wiring</i>	Front-entry wiring
<i>Width</i>	8 mm / 0.315 Inch
<i>Height from upper-edge of DIN-35 rail</i>	33.5 mm / 1.319 Inch
<i>Depth</i>	85 mm / 3.346 Inch
<i>Design</i>	angled
<i>Type of mounting</i>	Carrier rail 35 x 15
<i>Marking level</i>	Center marking
<i>Color</i>	gray
<i>Insulating material</i>	Polyamide 66 (PA 66)
<i>Fire load [MJ]</i>	0.293 [MJ]
<i>Weight [g]</i>	17.285 [g]
<i>Packaging type</i>	BOX
<i>Main product function</i>	Fuse term. block
<i>Product type</i>	Function modules

Images & drawings

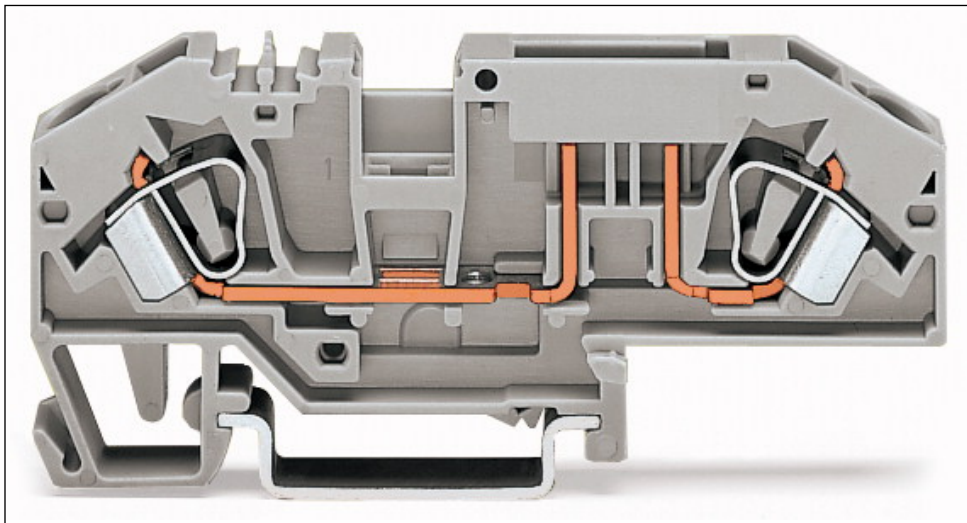

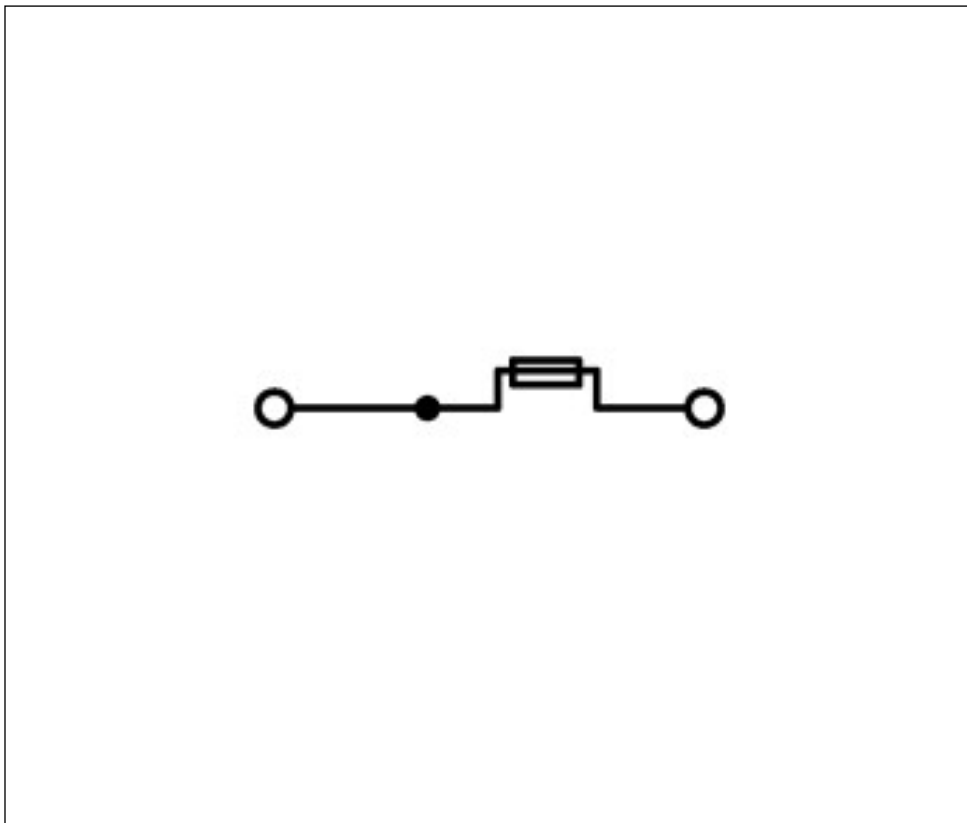
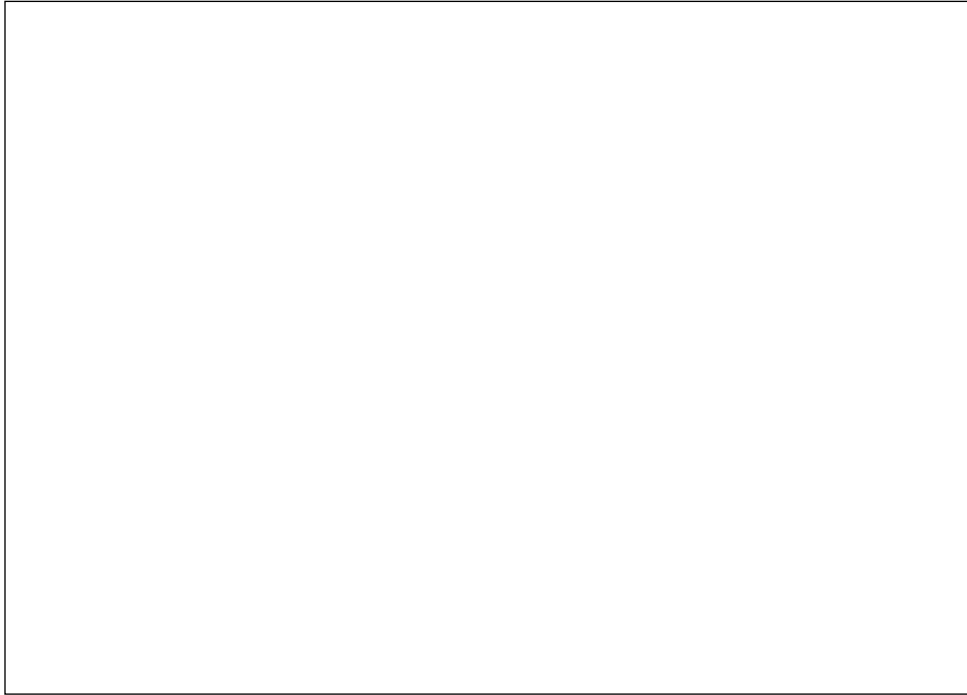

Address

WAGO Kontakttechnik GmbH & Co. KG

Hansastr. 27

32423 Minden

Telefon: 0571/887-0

Fax: 0571/887-169

<http://www.wago.com>

© WAGO Kontakttechnik GmbH & Co. KG

Technische Änderungen und Irrtümer vorbehalten.