

### Outline dimensions:

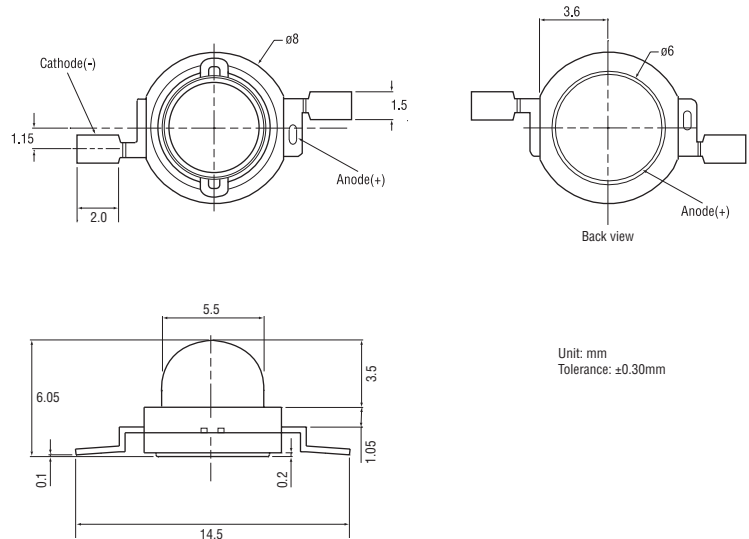

### Features:

- Highest luminous flux
- Super energy efficiency
- Long lifetime operation
- Superior ESD resistance
- Superior UV resistance

### Applications

- Read lights (car, bus, aircraft)
- Portable (flashlight, bicycle)
- Bollards/security/garden
- Traffic signalling/beacons
- Indoor/outdoor commercial lights

### Absolute maximum rating (Ta=25°C)

Item	Symbol	Value	Unit
DC forward current	$I_F$	400	mA
Pulse forward current*	$I_{FP}$	500	mA
Reverse voltage	$V_R$	5	V
Power dissipation	$P_D$	1200	mW
Operating temperature	$T_{opr}$	-30 to +85	°C
Storage temperature	$T_{stg}$	-40 to +100	°C
Lead soldering temperature	$T_{sol}$	260°C/5 sec	-

\*Pulse width max. 10ms. Duty ratio max. 1/10

### Directivity:

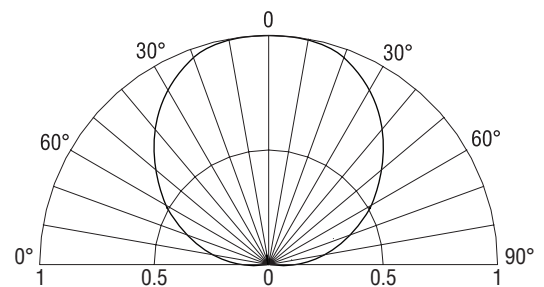

### Forward operating current (DC):

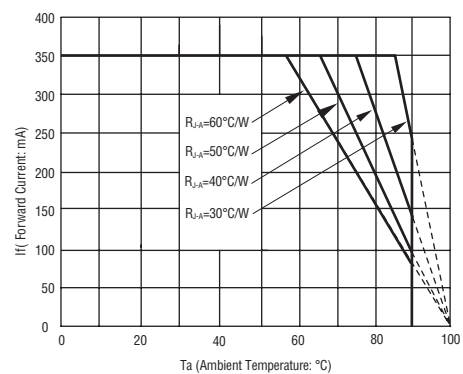

### Electrical - Optical characteristics (Ta=25°C)

Item	Symbol	Condition	Min.	Typ.	Max.	Unit
DC Forward voltage	$V_F$	$I_F = 350\text{mA}$	2.0	2.5	3.0	V
DC Reverse current	$I_R$	$V_R = 5\text{V}$	-	-	10	$\mu\text{A}$
Domi. wavelength	$\lambda_D$	$I_F = 350\text{mA}$	620	625	630	nm
Luminous flux	$\Phi_V$	$I_F = 350\text{mA}$	40	50	-	lm
50% Power angle	$2\theta_{1/2}$	$I_F = 350\text{mA}$	-	120	-	deg

Note: Don't drive at rated current more than 5s without heat sink for Xeon 1 emitter series.

## Handling of silicone lens LEDs

Notes for handling of silicone lens LEDs

- Do not use a force of over 3kgf impact or pressure on the silicone lens, otherwise it will cause a catastrophic failure
- The LEDs should only be picked up by making contact with the sides of the LED body
- Avoid touching the silicone lens especially with sharp tools such as tweezers
- Store the LEDs away from dusty areas or seal the product against dust
- When populating boards in SMT product, there are basically no restrictions regarding the form of the pick and place nozzle, expect that mechanical pressure on the silicon lens must be prevented
- Do not mould over the silicone lens with another resin . . . epoxy, urethane, etc.

