

Features:

- High luminous LEDs
- 5mm Round standard directivity
- Superior weather-resistance
- UV Resistant epoxy
- Integral current limiting resistor
- TTL Compatible (requires no external current limiter with 12 volt supply)
- Cost effective (saves space and resistor cost)
- Colour diffused type

Applications

- Status indicators
- Other lighting

Absolute maximum rating (Ta=25°C)

Item	Symbol	Value	Unit
DC Forward voltage	V_F	15	V
Reverse voltage	V_R	5	V
Power dissipation	P_D	225	mW
Operating temperature	T_{opr}	-30 to +85	°C
Storage temperature	T_{stg}	-40 to +100	°C
Lead soldering temperature	T_{sol}	260°C/5 sec	-

Electrical - Optical characteristics (Ta=25°C)

Item	Symbol	Condition	Min.	Typ.	Max.	Unit
DC Forward current	I_F	$V_F = 12V$	-	10	15	mA
DC Reverse current	I_R	$V_R = 12V$	-	-	10	μA
Domi. wavelength*	λ_D	$V_F = 12V$	585	590	595	nm
Luminous intensity †	I_V	$V_F = 12V$	100	130	-	mcd
50% Power angle	$2\theta_{1/2}$	$V_F = 12V$	-	60	-	deg

* Tolerance of dominant wavelength is $\pm 1nm$

† Tolerance of luminous intensity is $\pm 15\%$



Outline dimensions:

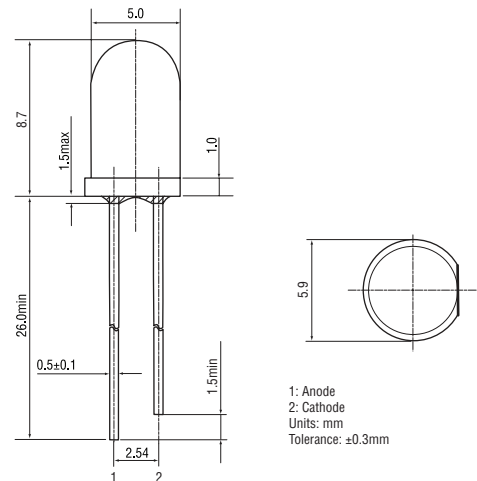

Directivity:

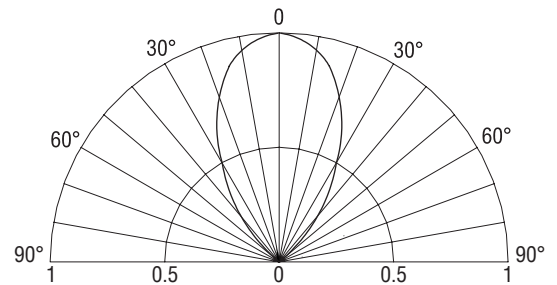

AlGaInP and Si Resistor LED

Typical electrical/optical characteristic curves

