



**Read these instructions and the accompanying safety information carefully before starting up the device and starting work with the device.**

Keep these instructions in a place that is accessible to all users.

Thank you for the confidence you have shown in buying this device. The device has been manufactured in accordance with the most rigorous quality standards which ensure that it operates perfectly.

These instructions contain important information which will help you to start up, operate and service the device safely and correctly as well as to eliminate simple faults and malfunctions yourselves.

Always pass on the device to third parties together with these operating instructions.

The device has been manufactured in accordance with state-of-the-art technology and acknowledged regulations concerning safety.

There is nevertheless the risk of personal injury and damage to property if you fail to observe the safety information set out in the accompanying booklet and the warnings given in these instructions.

## Safety information

This appliance can be used by children aged from 8 years and above and persons with reduced physical, sensory or mental capabilities or lack of experience and knowledge if they have been given supervision or instruction concerning use of the appliance in a safe way and understand the hazards involved. Children shall not play with the appliance.

Cleaning and user maintenance shall not be made by children without supervision.



### Warning! Electrical shock

If the device is faulty, active electrical conductors may be bare or the PE conductor may not be functional.

- Repairs must always be referred to a Weller-trained specialist.
- If the electrical tool's power supply cord is damaged, this must be replaced with a specially prefabricated power supply cord available through the customer service organisation.



### Warning! Danger of injury

The device or parts of the device may fall off during transportation.

- Hold the device by the intended handles only.
- Never use the device as a means of transportation.



### Warning! Danger of asphyxiation, Danger of poisoning

Improper installation can result in above-normal workplace concentrations

- Measure the workplace concentration upon completion of installation work

Inappropriate maintenance cycles for gas media may result in above-normal workplace concentrations

- Specify maintenance cycle

Above-normal contamination levels in the ambient air during cleaning work on the pipe system/extraction area

- If suction capacity is impaired by build-up within the pipe system, replace the contaminated parts

## Specified Conditions Of Use

### Applied directives

The Weller Zero Smog volume fume extraction system extraction unit corresponds to the EC Declaration of Conformity in accordance with the basic safety requirements of Directives 2004/108/EC, 2006/95/EC and 2011/65/EU (RoHS).

The manufacturer will not be liable for unauthorised modifications to the device.

This filtration system is suitable for the extraction and filtration of particles and gases, depending on the filter medium used.



### Warning! Danger of asphyxiation, Danger of poisoning

Improper use may result in respiratory problems, asphyxiation, poisoning or cancer

- Particles and gases which are unsuitable for the filter medium in use may not be extracted.
- Liquids and flammable gases may not be extracted
- Never use the device without a filter or with a full filter.
- Never use the device without the fan cover

This device may only be used at room temperature and indoors.

**Zero Smog 4V, Zero Smog 6V:** The unit is designed for use as a surface extraction unit and is not suitable for extracting fumes directly from the soldering gun.

**Zero Smog 20T:** The unit is designed for extracting fumes directly from the soldering gun and is not suitable for use as a surface extraction unit.

Intended use of the soldering station/ desoldering station also includes the requirement that you

- adhere to these instructions,
- observe all other accompanying documents,
- comply with national accident prevention guidelines applicable at the place of use.

## Efficiency test

In accordance with the general guidelines of the trade association, fume extractor systems must be checked regularly, at a minimum annually, in order to ensure that they are fully functional (TRGS 528 BGETF). The efficiency test also serves to check for proper functioning of the WFE 2S / WFE 4S and Zero Smog 4V / Zero Smog 6V / Zero Smog 20T solder fume extractor systems. Use the supplied software CD.

## User groups

Due to differing degrees of risk and potential hazards, several work steps may only be performed by trained experts.

Work step	User groups
Installation of complex pipe systems with multiple extractor arms connected	Specialist personnel with technical training
Replacing electrical replacement parts	Electricians
Specification of maintenance intervals	Safety expert
Operation Filter change	Non-specialists
Installation of complex pipe systems with multiple extractor arms connected Replacing electrical replacement parts	Technical trainees under the guidance and supervision of a trained expert

# Technical Data

Solder fume extraction	Zero Smog 4V	Zero Smog 6V	Zero Smog 20T
Dimensions L x W x H	320 x 320 x 395 mm	450 x 450 x 650 mm	450 x 450 x 695 mm
Weight	19 kg	40 kg	45 kg
Mains supply voltage	T0053660699: 230 V / 50 Hz T0053660299: 120 V / 60 Hz	T0053666699: 230 V / 50 Hz T0053666299: 120 V / 60 Hz	T0053670699: 230 V / 50 Hz T0053670299: 120 V / 60 Hz
Electrical power rating	275 VA	460 VA	530 VA
Fuse	T1, 6A	T3, 15A	T3, 15A
Maximum vacuum	2.700 Pa	2.800 Pa	10.000 Pa
Maximum quantity supplied	230 m <sup>3</sup> /h	615 m <sup>3</sup> /h	100 m <sup>3</sup> /h
Noise emission level	48 dB(A)	51 dB(A)	51 dB(A)
Pre filter Stage 1	pre filter mat class F7		
Combined filter Stage 2; 3	Particle filter H13 + Gas filter (50% Activated carbon + 50 % Chemisorb)		
RS232 port	All system functions can be operated and remotely monitored via the RS232 port.		
USB port	The USB port can be used to load firmware updates, run efficiency tests and log data. Do not leave the USB medium inserted for longer than 2 minutes. After this time expires, the USB module will switch off automatically.		

## Warranty

Claims by the buyer for physical defects are time-barred after a period of one year from delivery to the buyer. This does not apply to claims by the buyer for indemnification in accordance with §§ 478, 479 BGB (German Federal Law Gazette).

We shall only be liable for claims arising from a warranty furnished by us if the quality or durability warranty has been furnished by use in writing and using the term „Warranty“.

The warranty shall be void if damage is due to improper use and if the device has been tampered with by unauthorised persons.

**Subject to technical alterations and amendments.**

**For more information please visit [www.weller-tools.com](http://www.weller-tools.com)**

# Menu navigation

GB

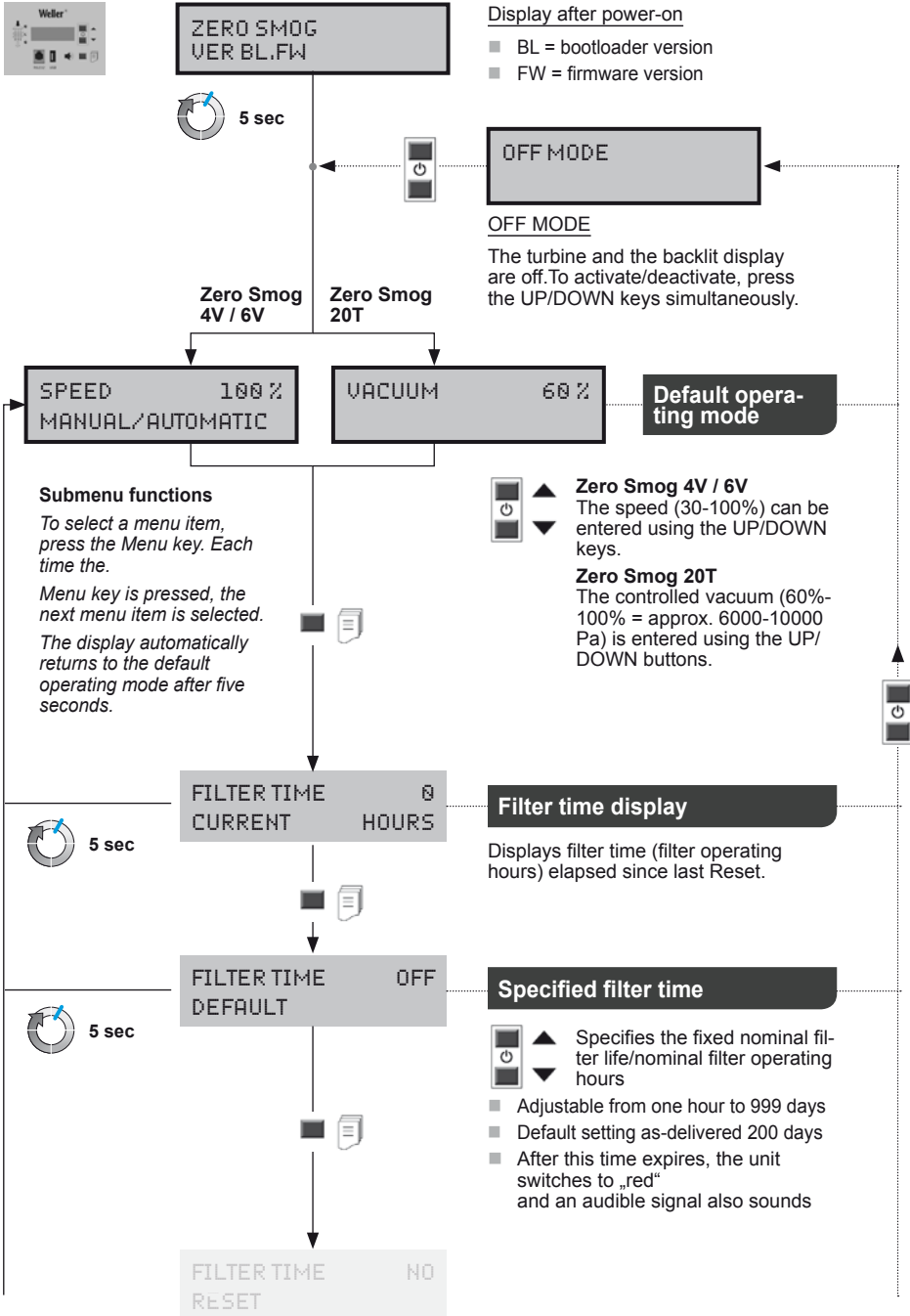

# Menu navigation

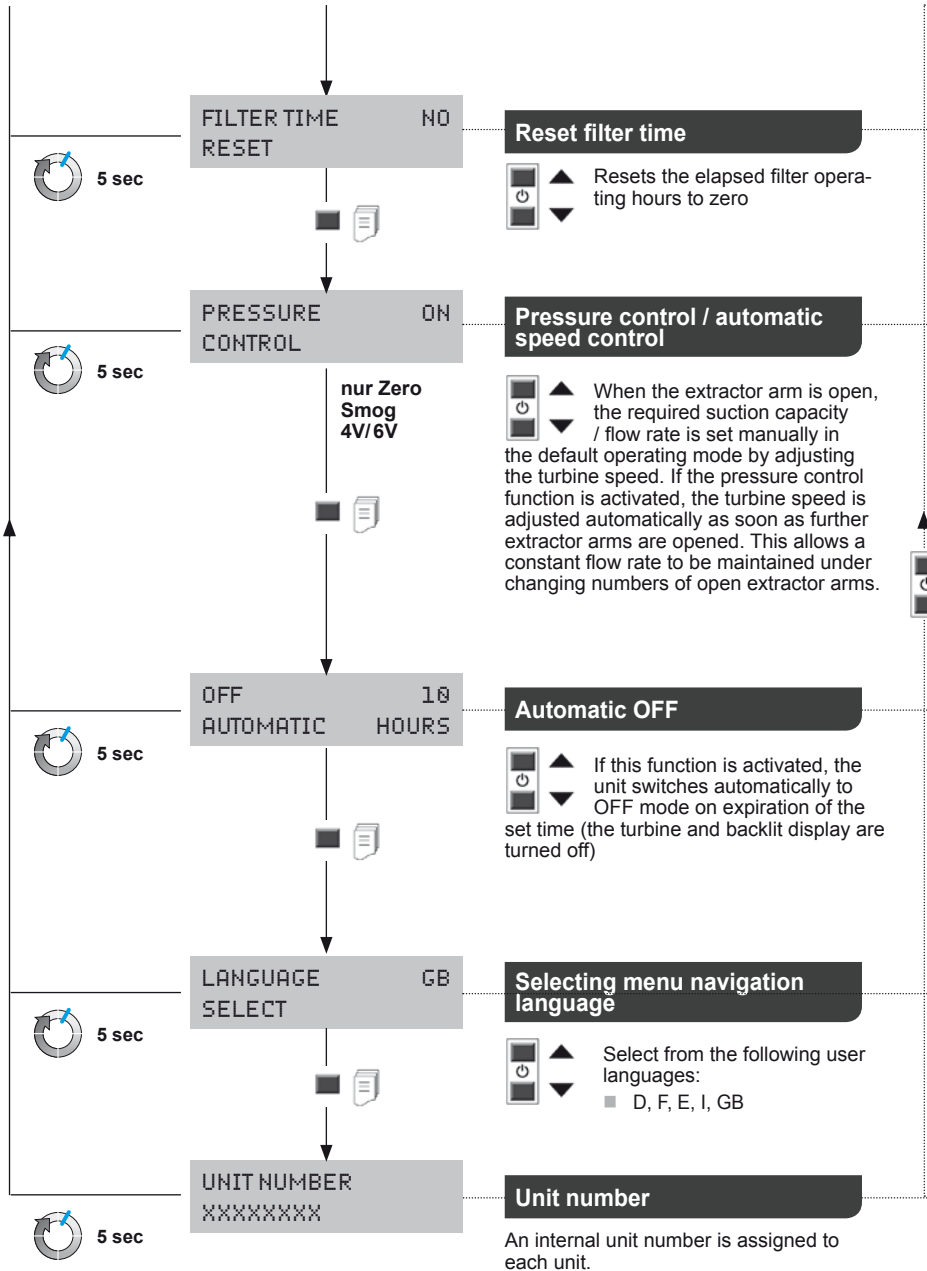

# Care and maintenance

## Warning!

Before doing any work on the machine, pull the plug out of the socket.

Use original replacement parts only.

Contaminated filters must be treated as special waste.

Dispose of replaced equipment parts, filters or old devices in accordance with the rules and regulations applicable in your country.

## Notice

Different fluxes and flux constituents and the amount of and size of dust particles in the extracted air will significantly affect the filters working life. A gas filter (without particle filter) must be used for the extraction of adhesive fumes.

To ensure that the filtration system functions properly, the filter must be replaced as follows

- at least once a year or
- when indicated or
- if the maximum allowable workplace concentration is exceeded or
- as per maintenance schedule

The degree of clogging of the filter is determined by differential pressure measurement. The filter display indicates the current filter status



- Red = filter full
- Yellow = filter status > 80%
- Green = filter status < 80%.

## When the filter is used up, an audible signal sounds

- once an hour
- every half hour after 36 hours
- every 10 min after 54 hours
- continuously after 72 hours.

The particle filter and the gas filter are co-ordinated in such a way that they can be replaced together as a compact filter unit. The compact filter must be changed once a year in order to ensure it is fully functional. The fine dust filter (filter mat) is the preliminary stage of the compact filter and therefore must be replaced more frequently. It is sufficient to replace the prefilter mat if the red LED does not come on after restarting the unit.

## Error messages and error clearance

Message/symptom	Possible cause	Remedial measures
■ Extraction power missing	■ Pipe system leaking	■ Reseal the pipe system
	■ Filter is dirty	■ change the filter
	■ Turbine speed too low	■ Increase the speed setting
■ Loud extraction noises	■ Air speed through extraction arm is too high speed	■ Reduce the air speed (reduce air quantity)
■ Zero Smog is not running	■ Thermally switched off	■ Leave the Zero Smog to cool down Switch on again after approx. 3 hours
■ Filter display is not working	■ Minimum pressure hose was not replaced after the filter change	■ Reconnect the hose to the filter
■ Particle filter depleted too quickly	■ Pre-filter has not been used	■ Use a pre-filter Fit an F7 filter Use a preliminary separator if the proportion of solid matter is high.
■ Unable to detect USB medium	■ USB medium inserted too long	■ Do not leave USB medium inserted for longer than 2 minutes. Remove USB medium and switch unit off and on again
■ Reset unit	■ Wrong USB medium > 100 mA	■ Remove USB medium!

## Original declaration of conformity

Solder fume extractor Zero Smog 4V  
Zero Smog 6V  
Zero Smog 20T

We hereby declare that the products described herein comply with the following guidelines:  
2011/65/EU (RoHS), 2004/108/EG, 2006/42/EG

Applied harmonised standards:

EN 55 014-1: 2012-05	EN 60 335-1: 2012-10
EN 55 014-2: 2009-06	EN 60 335-2-45: 2012-08
EN 61 000-3-2: 2010-03/2011-06	EN 62233: 2008-11/2009-04
EN 61 000-3-3: 2014-03	EN 50 581: 2013-02

**CE** Besigheim, 2015-10-22



T. Fischer  
Technical director



B. Frühwald  
Managing director

Authorised to compile technical documentation.

Weller Tools GmbH  
Carl-Benz-Straße 2, 74354 Besigheim, Germany

## Symbols



Caution!



Read the operating instructions!

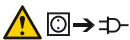

Before performing work of any kind on the unit, always disconnect the power plug from the socket.



ESD-compatible design and ESD-compatible workstation



CE mark of conformity



## Disposal

Do not dispose of electric tools together with household waste material! In observance of European Directive 2012/19/EU on waste electrical and electronic equipment and its implementation in accordance with national law, electric tools that have reached the end of their life must be collected separately and returned to an environmentally compatible recycling facility.

Contaminated filters must be treated as special waste.

Dispose of replaced equipment parts, filters or old devices in accordance with the rules and regulations applicable in your country.

# Zero Smog 4V

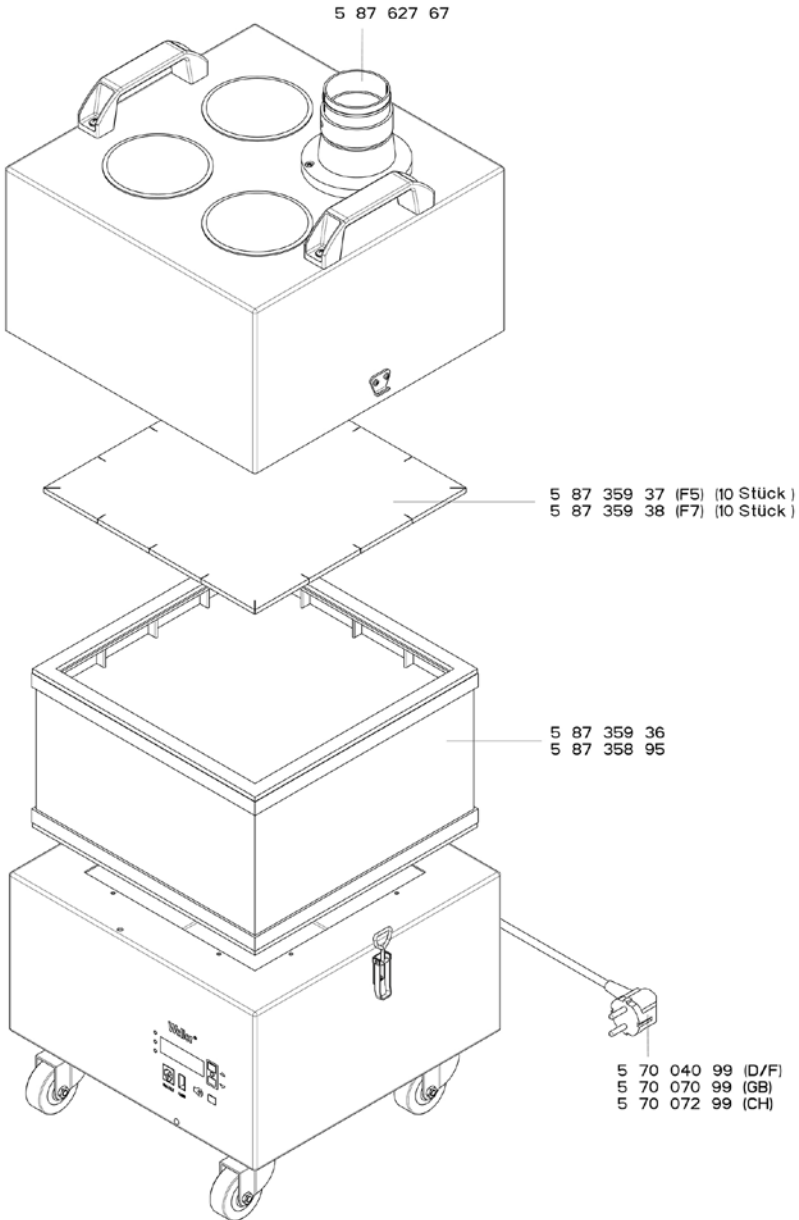

4D6R1051  
Zero-Smog 4V



# Zero Smog 6V

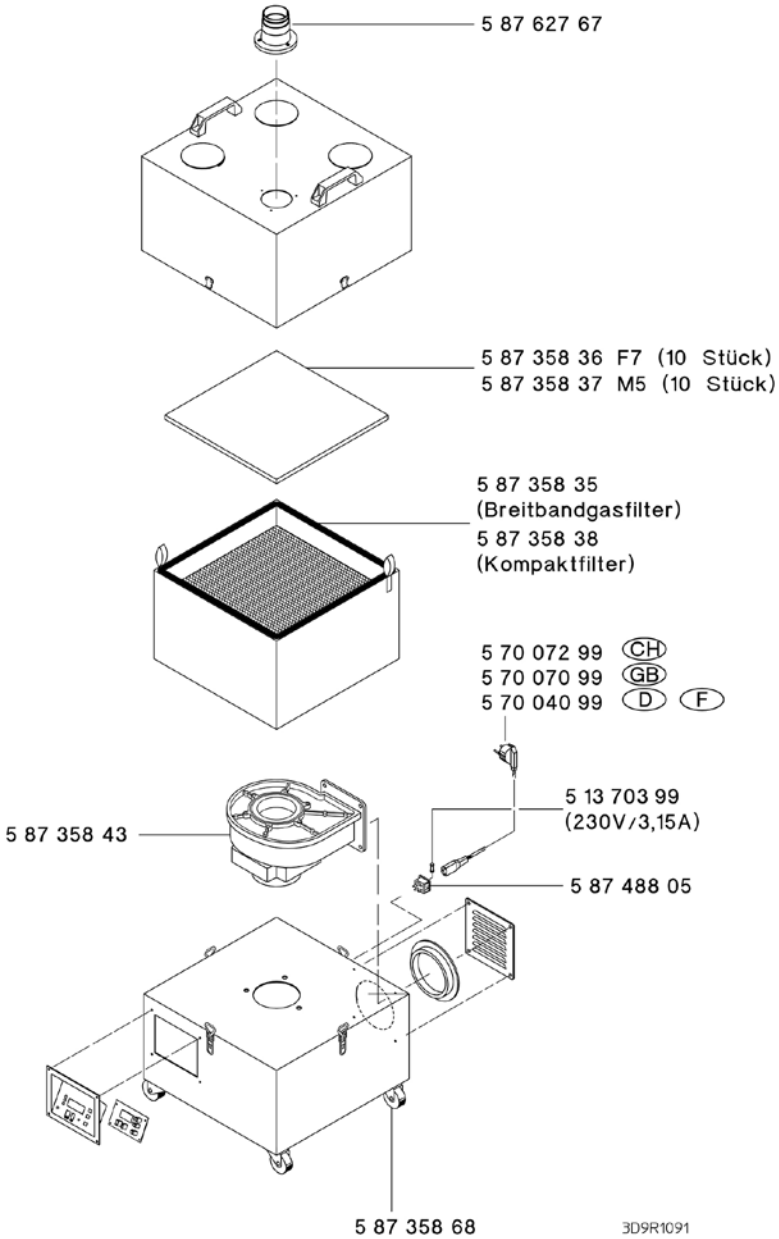

## GERMANY

Weller Tools GmbH  
Carl-Benz-Straße 2  
74354 Besigheim

Tel: +49 (0)7143 580-0  
Fax: +49 (0)7143 580-108

## ITALY

Apex Tool S.r.l.  
Viale Europa 80  
20090 Cusago (MI)

Tel: +39 (02)9033101  
Fax: +39 (02)90394231

## USA

Apex Tool Group, LLC  
14600 York Rd. Suite A  
Sparks, MD 21152

Tel: +1 (800)688-8949  
Fax: +1 (800)234-0472

## GREAT BRITAIN

Apex Tool Group (UK Operations) Ltd  
4th Floor Pennine House  
Washington, Tyne & Wear  
NE37 1LY

Tel: +44 (0) 191 419 7700  
Fax: +44 (0) 191 417 9421

## SWEDEN

Apex Tool Group AB  
William Gibsons väg 1A  
43376 Jonsered

Tel: +46 (0) 31 725 64 39  
Fax: +46 (0) 31 725 64 38

## CANADA

Apex Tools – Canada  
5925 McLaughlin Rd.  
Mississauga, Ontario L5R 1B8

Tel. +1 (905) 501-4785  
Fax. +1 (905) 387-2640

## FRANCE

Apex Tool Group S.N.C.  
25 Avenue Maurice Chevalier B.P. 46  
77832 Ozoir-la-Ferrière Cedex

Tel: +33 (0)1.64.43.22.00  
Fax: +33 (0)1.64.43.21.62

## CHINA

Apex Tool Group  
A-8 building  
No. 38 Dongsheng Road  
Heqing Industrial Park, Pudong  
Shanghai 201201

Tel: +86 (21)60880288  
Fax: +86 (21)60880289

## AUSTRALIA

Apex Tools  
P.O. Box 366  
519 Nurigong Street  
Albury, N.S.W. 2640  
Australia

Tel: +61 (2)6058-0300  
Fax: +61 (2)6021-7403

[www.weller-tools.com](http://www.weller-tools.com)  
[www.wellerft.com](http://www.wellerft.com)

© 2015, Apex Tool Group, LLC.  
Weller® is a registered Trademark and registered Design of Apex Tool Group, LLC.

**Weller®FT**  
FILTER SYSTEMS