

D.C. miniature gear-motors



micro
motors s.r.l.



t e c h n o l o g y i n m o t i o n



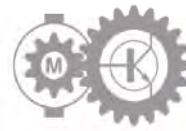

D.C. miniature gear-motors



index

motor

general guide - gear-motors	page 3
1271	page 4
B138F	page 5
B138F.4/12	page 6
BS138F	page 7
BS138F.4/12	page 8
HL149	page 9
HV155	page 10
1308	page 11
E192 - planetary	page 12
P205 - planetary	page 13

encoder

general guide - gear-motors with encoder	page 14
--	---------



gear-motors with two-phase Hall-effect 90° encoder



gear-motors with Hall-effect encoder

technical data - encoder	page 15
1271-2S	page 17
BS138F-2S	page 18
HL149-2S - HV155-2S	page 19
1308-2S	page 20
E192-2S	page 21
P205-2S	page 21

technical data - encoders	page 16
1271-E	page 17
BSE138F	page 18
HLE149 - HVE155	page 19
1308E	page 20





general guide

gear - motors



TYPE		1271	B138F BS138F	B138F.4/12 BS138F.4/12	HL149	HV155	1308	E192	P205
Voltage	V	4-6-12	6-12	12	12-24	12-24	12-24	12-24	12-24
Reduction		10 ÷ 392	12 ÷ 1470	12 ÷ 608	10 ÷ 90	10 ÷ 90	30 ÷ 630	3 ÷ 625	4 ÷ 625
Max Torque	Ncm	20	50	50	15	25	100	300	900
Speed (no load)	RPM	255 ÷ 6	220 ÷ 1.8	320 ÷ 6.5	315 ÷ 37	660 ÷ 75	110 ÷ 5	1100 ÷ 6.4	1024 ÷ 6.7
Speed (max Torque)	RPM	165 ÷ 4	155 ÷ 1.6	250 ÷ 5.3	220 ÷ 30	460 ÷ 62	70 ÷ 4.5	770 ÷ 6	640 ÷ 6.3
Dimensions	mm	Ø 27	Ø 34	Ø 34	Ø 30	Ø 30	Ø 39.6	Ø 40.5	42 x 42

NOTE: It is recommended to avoid the use of the motor's internal inductance in PWM drive applications. It is advisable to use an external series inductance.



1271
page 4



HL149
page 9



B138F
page 5



HV155
page 10



B138F.4/12
page 6



1308
page 11



BS138F
page 7



BS138F.4/12
page 8

planetary



E192
page 12

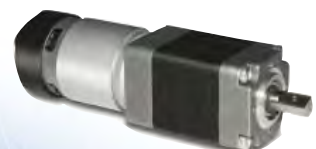

P205
page 13



TECHNICAL DATA

series

1271

- VDR interference suppression on the collector
- Precious metal brushes (Au - Ag - Cu)
- Direction of rotation depending on polarity
- Can be mounted in any position
- Maximum radial shaft load: 10N
- Maximum axial shaft load: 5N
- Temperature range: -20°C/60°C
- Approx weight: 55g



Typical values at ambient temperature +20°
Tolerance +/- 10%

TYPE	NOMINAL VOLTAGE	L	RATIO TO:1	MAXIMUM TORQUE	SPEED		CURRENT	
					NO LOAD	AT MAX TORQUE	NO LOAD	AT MAX TORQUE
					rpm		mA	
1271-4-6-10	4.5	36	10	1.5	255	165	<35	100
	6				215	120	<30	85
	12				255	165	<20	50
1271-4-6-21	4.5	36	20.8	2.5	125	80	<35	100
	6				105	60	<30	85
	12				125	80	<20	50
1271-4-6-43	4.5	41	43.3	3.8	60	40	<35	100
	6				52	32	<30	85
	12				60	40	<20	50
1271-4-6-90	4.5	41	90.3	8	30	18	<35	100
	6				25	13	<30	85
	12				30	18	<20	50
1271-4-6-188	4.5	46	188	14	14	9	<35	100
	6				12	7	<30	85
	12				14	9	<20	50
1271-4-6-392	4.5	46	391.8	20	7	5	<35	90
	6				6	4	<30	75
	12				7	5	<20	45

1271

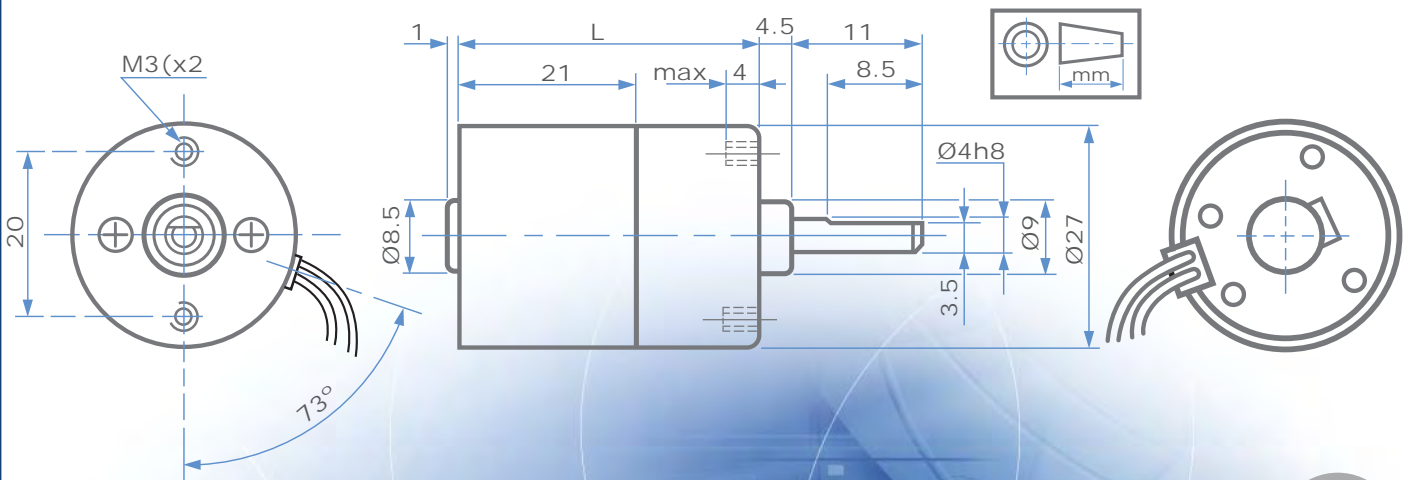



TECHNICAL DATA

series

B138F



VDR interference suppression on the collector
 Precious metal brushes (Au - Ag - Cu)
 Direction of rotation depending on polarity
 Can be mounted in any position
 Maximum radial shaft load: 20N
 Maximum axial shaft load: 5N
 Temperature range: -20°C/60°C
 Approx weight: 85g



Typical values at ambient temperature +20°
 Tolerance +/- 10%

TYPE	NOMINAL VOLTAGE	L	RATIO TO: 1	MAXIMUM TORQUE	SPEED		CURRENT	
					NO LOAD	AT MAX TORQUE	NO LOAD	AT MAX TORQUE
	v	mm	Ncm	rpm	mA			
B138F- $\frac{6}{12}$ ·12	$\frac{6}{12}$	37.5	12.25	1.5	220	155	<30 <20	100 55
B138F- $\frac{6}{12}$ ·21	$\frac{6}{12}$	37.5	21.14	2.5	125	85	<30 <20	100 55
B138F- $\frac{6}{12}$ ·36	$\frac{6}{12}$	37.5	35.73	4	73	53	<30 <20	95 50
B138F- $\frac{6}{12}$ ·72	$\frac{6}{12}$	37.5	71.54	7	37	28	<30 <20	95 50
B138F- $\frac{6}{12}$ ·149	$\frac{6}{12}$	37.5	149.05	14	18	13	<30 <20	95 50
B138F- $\frac{6}{12}$ ·208	$\frac{6}{12}$	37.5	208.66	20	13	9	<30 <20	95 50
B138F- $\frac{6}{12}$ ·608	$\frac{6}{12}$	37.5	608.61	50	4.3	3.3	<30 <20	90 48
B138F- $\frac{6}{12}$ ·1470	$\frac{6}{12}$	37.5	1470.82	50	1.8	1.6	<30 <20	58 30

B138F

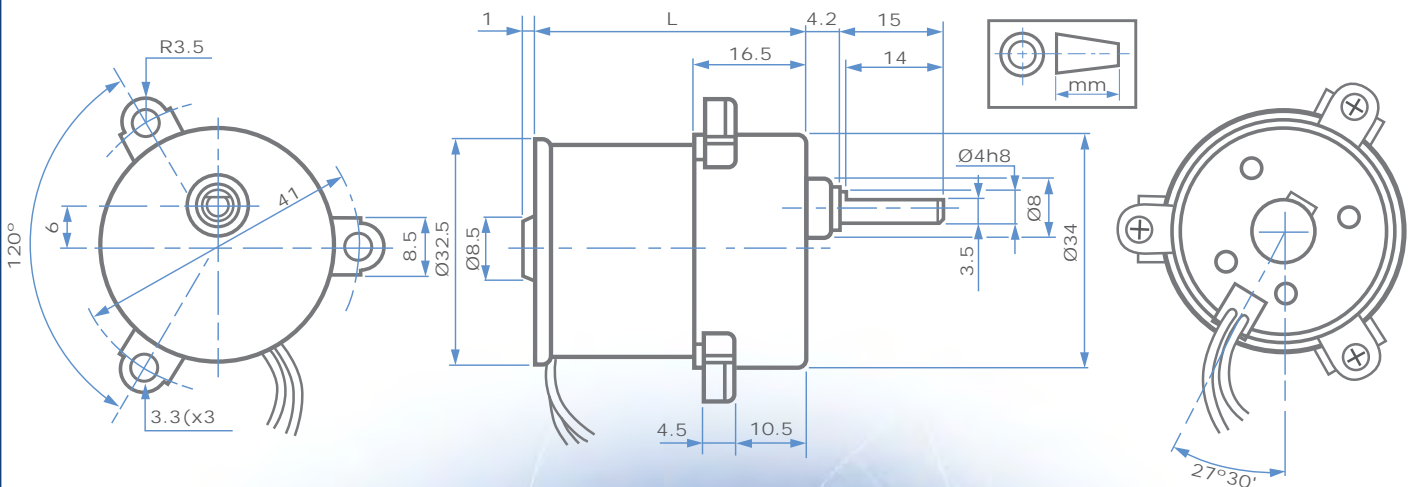

B138F



TECHNICAL DATA

series

B138F.4/12

- VDR interference suppression on the collector
- Precious metal brushes (Au - Ag - Cu)
- Direction of rotation depending on polarity
- Can be mounted in any position
- Maximum radial shaft load: 20N
- Maximum axial shaft load: 5N
- Temperature range: -20°C/60°C
- Approx weight: 85g



Typical values at ambient temperature +20°
Tolerance +/- 10%

TYPE	NOMINAL VOLTAGE	L	RATIO TO: 1	MAXIMUM TORQUE	SPEED		CURRENT	
					NO LOAD	AT MAX TORQUE	NO LOAD	AT MAX TORQUE
					rpm		mA	
B138F - 4/12 - 12	12	37.5	12.25	1.5	320	250	<30	80
B138F - 4/12 - 21	12	37.5	21.14	2.5	190	150	<30	80
B138F - 4/12 - 36	12	37.5	35.73	4.2	108	86	<30	80
B138F - 4/12 - 72	12	37.5	71.54	8.2	54	43	<30	80
B138F - 4/12 - 149	12	37.5	149.05	15	27	20	<30	80
B138F - 4/12 - 208	12	37.5	208.66	20	19	14	<30	80
B138F - 4/12 - 608	12	37.5	608.61	50	6.5	5.3	<30	75

B138F.4/12

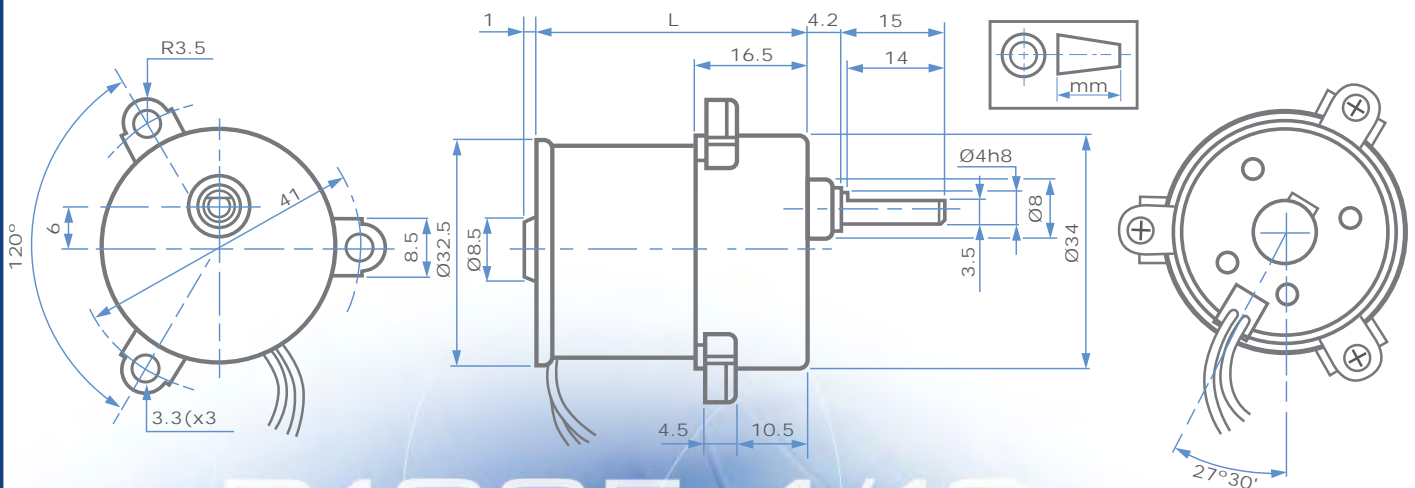

B138F.4/12



TECHNICAL DATA

series

BS138F



- VDR interference suppression on the collector
- Precious metal brushes (Au - Ag - Cu)
- Direction of rotation depending on polarity
- Can be mounted in any position
- Maximum radial shaft load: 20N
- Maximum axial shaft load: 5N
- Temperature range: -20°C/60°C
- Approx weight: 90g



Typical values at ambient temperature +20°
Tolerance +/- 10%

TYPE	NOMINAL VOLTAGE	L	RATIO TO: 1	MAXIMUM TORQUE	SPEED		CURRENT	
					NO LOAD	AT MAX TORQUE	NO LOAD	AT MAX TORQUE
					rpm		mA	
	v	mm		Ncm				
BS138F· $\frac{6}{12}$ ·12	$\frac{6}{12}$	40	12.25	1.5	220	155	<30 <20	100 55
BS138F· $\frac{6}{12}$ ·21	$\frac{6}{12}$	40	21.14	2.5	125	85	<30 <20	100 55
BS138F· $\frac{6}{12}$ ·36	$\frac{6}{12}$	40	35.73	4	73	53	<30 <20	95 50
BS138F· $\frac{6}{12}$ ·72	$\frac{6}{12}$	40	71.54	7	37	28	<30 <20	95 50
BS138F· $\frac{6}{12}$ ·149	$\frac{6}{12}$	40	149.05	14	18	13	<30 <20	95 50
BS138F· $\frac{6}{12}$ ·208	$\frac{6}{12}$	40	208.66	20	13	9	<30 <20	95 50
BS138F· $\frac{6}{12}$ ·608	$\frac{6}{12}$	40	608.61	50	4.3	3.3	<30 <20	90 48
BS138F· $\frac{6}{12}$ ·1470	$\frac{6}{12}$	40	1470.82	50	1.8	1.6	<30 <20	58 30

BS138F

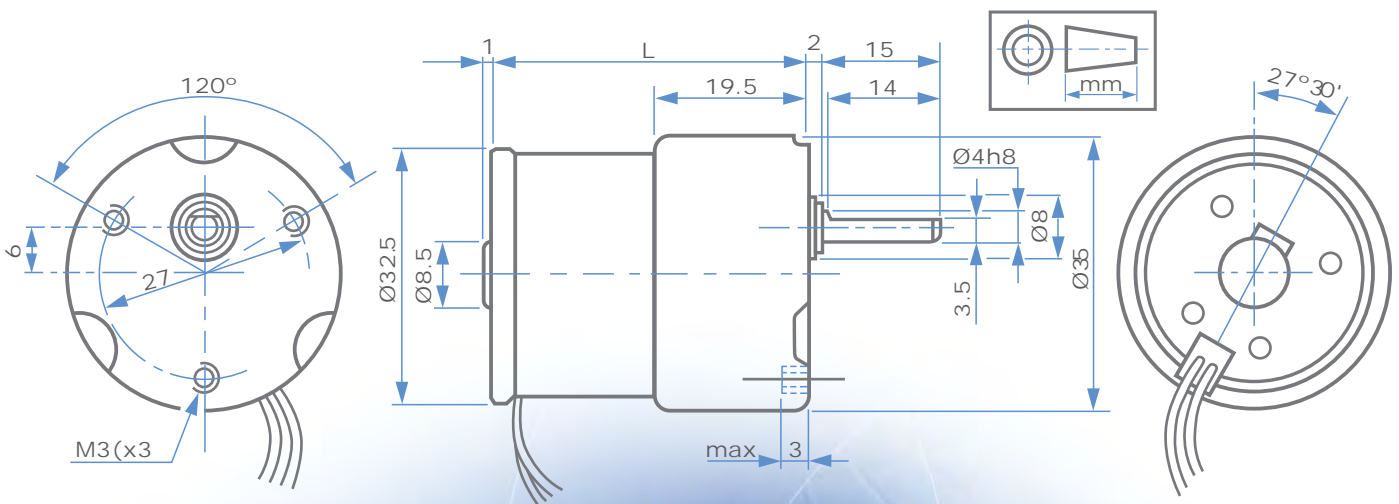

BS138F



TECHNICAL DATA

series

HL149

- VDR interference suppression on the collector
- Direction of rotation depending on polarity
- Can be mounted in any position
- Maximum radial shaft load: 10N
- Maximum axial shaft load: 5N
- Temperature range: -20°C/60°C
- Approx weight: 100g



Typical values at ambient temperature +20°
Tolerance +/- 10%

TYPE	NOMINAL VOLTAGE	L	RATIO TO: 1	MAXIMUM TORQUE	SPEED		CURRENT	
					NO LOAD	AT MAX TORQUE	NO LOAD	AT MAX TORQUE
					rpm		mA	
HL149-12-24-10	12 24	57.5	10	4	315	220	<60 <50	210 120
HL149-12-24-21	12 24	57.5	20.8	7.5	160	115	<60 <50	200 115
HL149-12-24-43	12 24	62.5	43.3	15	78	55	<60 <50	210 120
HL149-12-24-90	12 24	62.5	90.3	15	37	30	<60 <50	150 85

HL149

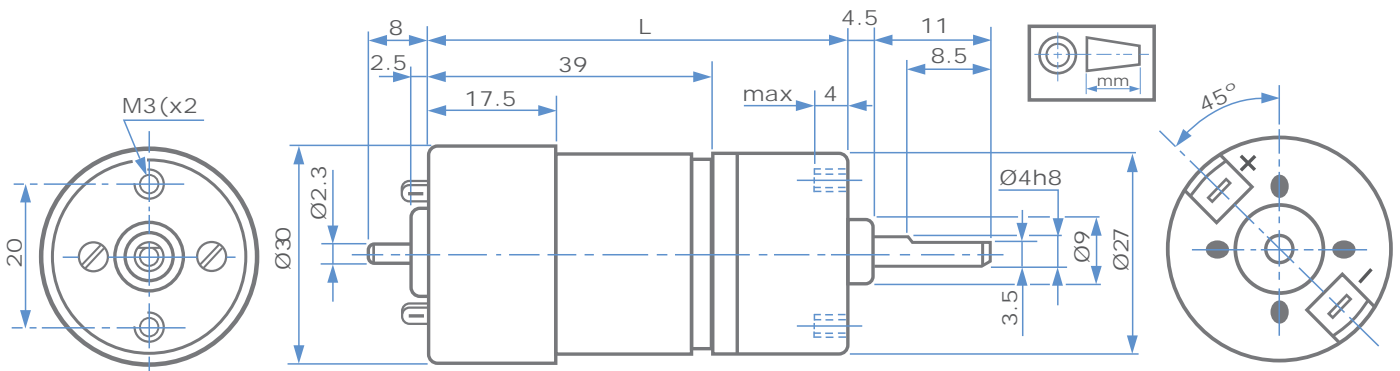

HL149



TECHNICAL DATA

series **HV155**

VDR interference suppression on the collector
 Direction of rotation depending on polarity
 Can be mounted in any position
 Maximum radial shaft load: 10N
 Maximum axial shaft load: 5N
 Temperature range: -20°C/60°C
 Approx weight: 100g



Typical values at ambient temperature +20°
 Tolerance +/- 10%

TYPE	NOMINAL VOLTAGE	L mm	RATIO TO: 1	MAXIMUM TORQUE Ncm	SPEED		CURRENT	
					NO LOAD	AT MAX TORQUE	NO LOAD	AT MAX TORQUE
					rpm		mA	
HV155 · 12 · 10 24 · 10	12 24	62.5	10	5	660	460	<140 <70	620 300
HV155 · 12 · 21 24 · 21	12 24	62.5	20.8	10	315	235	<140 <70	600 285
HV155 · 12 · 43 24 · 43	12 24	67.5	43.3	18	155	115	<140 <70	580 280
HV155 · 12 · 90 24 · 90	12 24	67.5	90.3	25	75	62	<140 <70	440 215

HV155

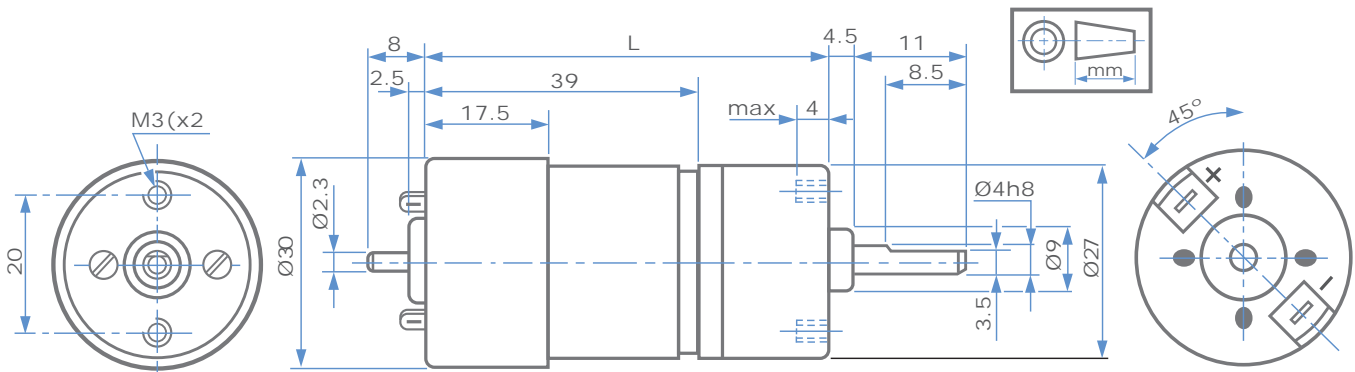

HV155



TECHNICAL DATA

series

1308



- VDR interference suppression on the collector
- Direction of rotation depending on polarity
- Can be mounted in any position
- Maximum radial shaft load: 50N
- Maximum axial shaft load: 10N
- Temperature range: -20°C/60°C
- Approx weight: 190g



Typical values at ambient temperature +20°
Tolerance +/- 10%

TYPE	NOMINAL VOLTAGE	L	RATIO TO:1	MAXIMUM TORQUE	SPEED		CURRENT	
					NO LOAD	AT MAX TORQUE	NO LOAD	AT MAX TORQUE
					v	mm	Ncm	rpm
1308 · 12/24 · 30	12/24	64	29.75	15	110	70	<60 <50	250 130
1308 · 12/24 · 75	12/24	66.5	76.84	30	43	28	<60 <50	230 120
1308 · 12/24 · 100	12/24	66.5	94.37	40	35	22	<60 <50	240 125
1308 · 12/24 · 200	12/24	69	198.5	80	17	10	<60 <50	250 130
1308 · 12/24 · 250	12/24	69	243.8	100	14	8.5	<60 <50	240 125
1308 · 12/24 · 510	12/24	72	512.85	100	6.5	5	<60 <50	150 80
1308 · 12/24 · 630	12/24	72	629.82	100	5	4.5	<60 <50	130 70

1308

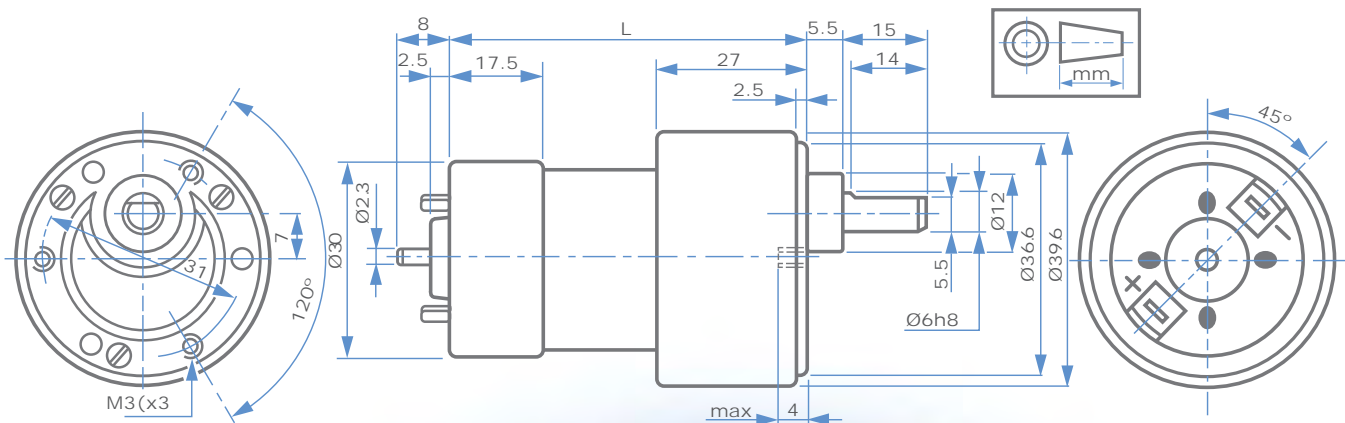



TECHNICAL DATA

series

E192



Planetary gear-motor
 Motor interference suppression by VDR and capacitors
 Outgoing shaft two ball bearings supported
 Maximum radial shaft load: 200N
 (10 mm from the fixing flange)
 Maximum axial shaft load: 100N
 Direction of rotation depending on polarity
 Can be mounted in any position
 Temperature working range: -20°C/60°C
 Approx weight: 385/480g



Typical values at ambient temperature +20°
 Tolerance +/- 10%

TYPE	NOMINAL VOLTAGE	L	RATIO TO: 1	MAXIMUM TORQUE	SPEED		CURRENT		INPUT POWER AT MAX TORQUE
					NO LOAD	AT MAX TORQUE	NO LOAD	AT MAX TORQUE	
	V	mm		Ncm	rpm		A	W	
E192 · 12 · 3 24	12 24	86	3.66	15	1100 1100	700 770	<0.4 <0.2	1.70 0.96	20.4 23
E192 · 12 · 5 24	12 24	86	5	20	800 830	510 575	<0.4 <0.2	1.75 0.95	21 22.8
E192 · 12 · 13 24	12 24	93	13.44	45	300 300	200 225	<0.4 <0.2	1.65 0.85	19.8 20.4
E192 · 12 · 18 24	12 24	93	18.33	60	218 226	155 170	<0.4 <0.2	1.65 0.84	19.8 20.2
E192 · 12 · 25 24	12 24	93	25	90	160 166	105 118	<0.4 <0.2	1.75 0.88	21 21.1
E192 · 12 · 49 24	12 24	100	49.29	160	82 82	58 60	<0.4 <0.2	1.60 0.85	19.2 20.4
E192 · 12 · 67 24	12 24	100	67.22	220	59.5 61.5	40 45	<0.4 <0.2	1.80 0.88	21.6 21.1
E192 · 12 · 91 24	12 24	100	91.66	270	43.6 45	31 34	<0.4 <0.2	1.70 0.85	20.4 20.4
E192 · 12 · 125 24	12 24	100	125	300	32 33	24 26	<0.4 <0.2	1.32 0.64	15.9 15.4
E192 · 12 · 180 24	12 24	107	180.75	220	22 22	20 20	<0.4 <0.2	0.75 0.42	9 10.1
E192 · 12 · 246 24	12 24	107	246.48	300	15.2 16.8	14.5 15	<0.4 <0.2	0.87 0.43	10.5 10.3
E192 · 12 · 336 24	12 24	107	336.11	300	11.9 12.3	11 11.5	<0.4 <0.2	0.69 0.34	8.3 8.2
E192 · 12 · 458 24	12 24	107	458.3	300	9 9.5	8.5 9	<0.4 <0.2	0.54 0.28	6.5 6.7
E192 · 12 · 625 24	12 24	107	625	300	6.4 6.6	6 6.2	<0.4 <0.2	0.46 0.23	5.5 5.5

E192

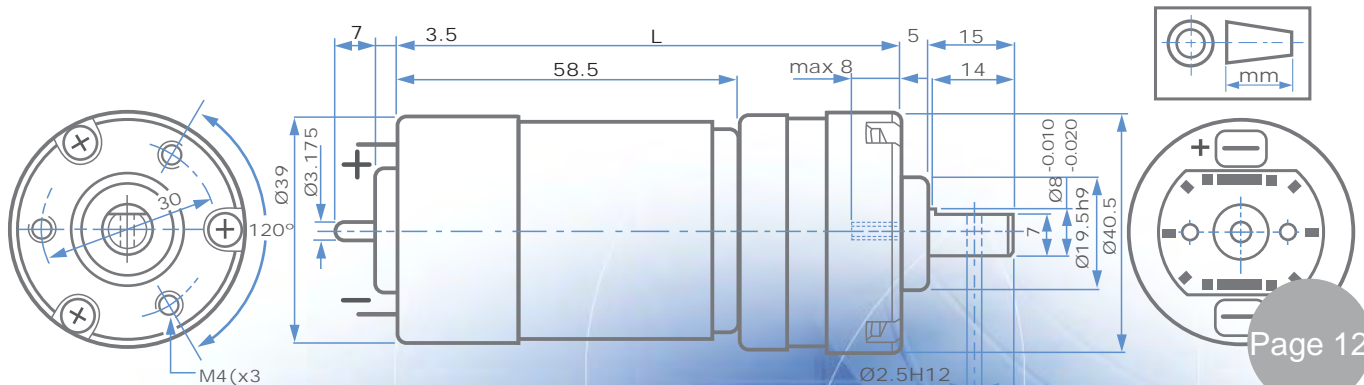

micro motors

Page 12



TECHNICAL DATA

series

P205



Planetary gear-motor
 Motor interference suppression by VDR
 Outgoing shaft supported by two ball bearings
 Maximum radial shaft load: 300N
 (10 mm from the fixing flange)
 Maximum axial shaft load: 150N
 Direction of rotation depending on polarity
 Can be mounted in any position
 Working temperature range: -20°C/60°C
 Approx weight: 700/900g

Typical values at ambient temperature +20°
 Tolerance +/- 10%

TYPE	NOMINAL VOLTAGE	L	RATIO TO: 1	MAXIMUM TORQUE	SPEED		CURRENT		INPUT POWER AT MAX TORQUE
					NO LOAD	AT MAX TORQUE	NO LOAD	AT MAX TORQUE	
					rpm	A	W		
P205 · 12/24 · 4	12/24	120.5	4	50	1024/1017	625/640	<0.7/<0.4	5.45/2.70	65.4/64.8
P205 · 12/24 · 6	12/24	120.5	6.25	60	656/652	459/470	<0.7/<0.4	4.20/2.15	50.4/51.6
P205 · 12/24 · 16	12/24	133	16	150	257/256	178/186	<0.7/<0.4	4.50/2.20	54.0/52.8
P205 · 12/24 · 25	12/24	133	25	250	165/165	110/116	<0.7/<0.4	4.55/2.30	54.6/55.2
P205 · 12/24 · 39	12/24	133	39.06	350	106/105	75/77	<0.7/<0.4	4.20/2.10	50.4/50.4
P205 · 12/24 · 64	12/24	145.5	64	600	64/64	41.5/45	<0.7/<0.4	4.80/2.40	57.6/57.6
P205 · 12/24 · 100	12/24	145.5	100	700	41.3/41.3	30.3/32.4	<0.7/<0.4	3.60/1.75	43.2/42.0
P205 · 12/24 · 156	12/24	145.5	156.25	800	26.5/26.5	21.3/22	<0.7/<0.4	2.85/1.45	34.2/34.8
P205 · 12/24 · 244	12/24	145.5	244.14	900	16.9/16.9	14.9/14.9	<0.7/<0.4	2.20/1.10	26.4/26.4
P205 · 12/24 · 400	12/24	158	400	900	10.2/10.2	9.4/9.4	<0.7/<0.4	1.65/0.85	19.8/20.4
P205 · 12/24 · 625	12/24	158	625	900	6.7/6.7	6.3/6.3	<0.7/<0.4	1.25/0.65	15.0/15.6

P205

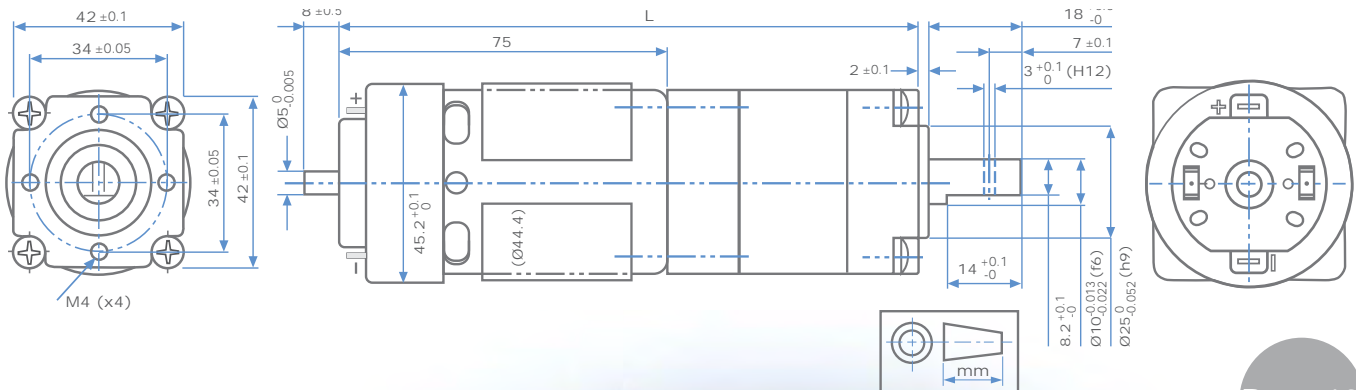

optional encoders

gear-motors with two-phase
Hall-effect 90° encoder

1271-2S
page 17



BS138F-2S
page 18



HL149-2S
HV155-2S
page 19



1308-2S
page 20



E192-2S
page 21



P205-2S
page 21



gear-motors with Hall-effect
encoder

1271E
page 17



BSE138F
page 18



HLE149
HVE155
page 19



1308E
page 20



micro
motors s.r.l.

technology in motion

Page 14

gear-motors with two-phase Hall-effect 90° encoder

SIX POLES MAGNET:

THREE PULSES FOR MOTOR TURN

The sequence of the phases A-B is obtained connecting the motor with the polarities printed on the black bottom cover.

HALL-EFFECT SWITCHES

These Hall-effect switches are highly temperature stable and stress-resistant sensors best utilized in applications that provide steep magnetic slopes and low residual levels of magnetic flux density. Each device includes a voltage regulator, quadratic Hall voltage generator, temperature stability circuit, signal Schmitt chopper stabilized amplifier, Schmitt trigger and an open drain mosfet on a single silicon chip.

The on-board regulator permits operation with supply voltages of 3.5 to 24V. The output mosfet can sink up to 20 mA with suitable output pull up. they can be used directly with bipolar or MOS logic circuits.

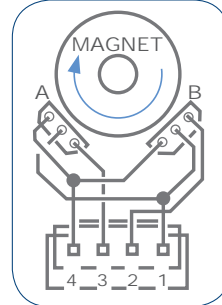

connections

- 1 Green: GROUND
- 2 Yellow: O.C. B NPN
- 3 Blue: O.C. A NPN
- 4 Brown: Vcc (Hall)



ABSOLUTE MAXIMUM RATINGS

PARAMETER	SYMBOL	VALUE	UNITS
Supply Voltage	VDD	28	V
Supply Current	IDD	50	mA
Output Voltage	VOUT	28	V
Output Current	IOUT	50	mA
Storage Temperature Range	TS	-50 to 150	°C
Maximum Junction Temperature	TJ	165	°C

Exceeding the absolute maximum ratings may cause permanent damage. Exposure to all absolute-maximum-rated conditions for extended periods may affect device reliability.



GENERAL ELECTRICAL SPECIFICATIONS

PARAMETER	SYMBOL	TEST CONDITIONS	MIN	TYPE	MAX	UNITS
Supply Voltage	VDD	Operating	3.5	-	24	V
Supply Current	IDD	B<BRP	-	-	5	mA
Output Saturation Voltage	VDSon	IOUT=20mA. B>BOP	-	-	0.5	V
Output Leakage Current	IOFF	IB<BRP. VOUT=24V	-	0.3	10	µA
Output Rise Time	tr	RL=1kΩ. CL=20pF	-	0.25	-	µs
Output Fall Time	tr	RL=1kΩ. CL=20pF	-	0.25	-	µs

OC Operating Parameters TA = 25 °C, VDD = 3.5V to 24V (unless otherwise specified)

gear-motors with Hall-effect encoder

SIX POLES MAGNET:
THREE PULSES FOR MOTOR TURN

HALL-EFFECT SWITCHES

Hall-effect switches are highly temperature stable and stress-resistant sensors best utilized in applications that provide steep magnetic slopes and low residual levels of magnetic flux density. Each device includes a voltage regulator, quadratic Hall voltage generator, temperature stability circuit, signal chopper stabilized amplifier, Schmitt trigger and an open drain mosfet on a single silicon chip. The on-board regulator permits operation with supply voltages of 3.5 to 24V. The output mosfet can sink up to 20 mA with suitable output pull up. they can be used directly with bipolar or MOS logic circuits.

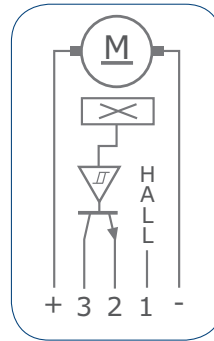

connections

+ Red	: +Motor
3 Blue	: O.C. Output
2 Green	: Ground
1 Brown	: Vcc (Hall)
- Black	: -Motor



ABSOLUTE MAXIMUM RATINGS

PARAMETER	SYMBOL	VALUE	UNITS
Supply Voltage	VDD	28	V
Supply Current	IDD	50	mA
Output Voltage	VOUT	28	V
Output Current	IOUT	50	mA
Storage Temperature Range	TS	-50 to 150	°C
Maximum Junction Temperature	TJ	2.0	°C

Exceeding the absolute maximum ratings may cause permanent damage. Exposure to all absolute-maximum-rated conditions for extended periods may affect device reliability.



GENERAL ELECTRICAL SPECIFICATIONS

PARAMETER	SYMBOL	TEST CONDITIONS	MIN	TYPE	MAX	UNITS
Supply Voltage	VDD	Operating	3.5	-	24	V
Supply Current	IDD	B<BRP	-	-	5	mA
Output Saturation Voltage	VDSon	IOUT=20mA. B>BOP	-	-	0.5	V
Output Leakage Current	IOFF	IB<BRP. VOUT=24V	-	0.3	10	µA
Output Rise Time	tr	RL=1kΩ. CL=20pF	-	0.25	-	µs
Output Fall Time	tr	RL=1kΩ. CL=20pF	-	0.25	-	µs

OC Operating Parameters TA = 25 °C, VDD = 3.5V to 24V (unless otherwise specified)



gear-motors with two-phase Hall-effect 90° encoder

1271-2S

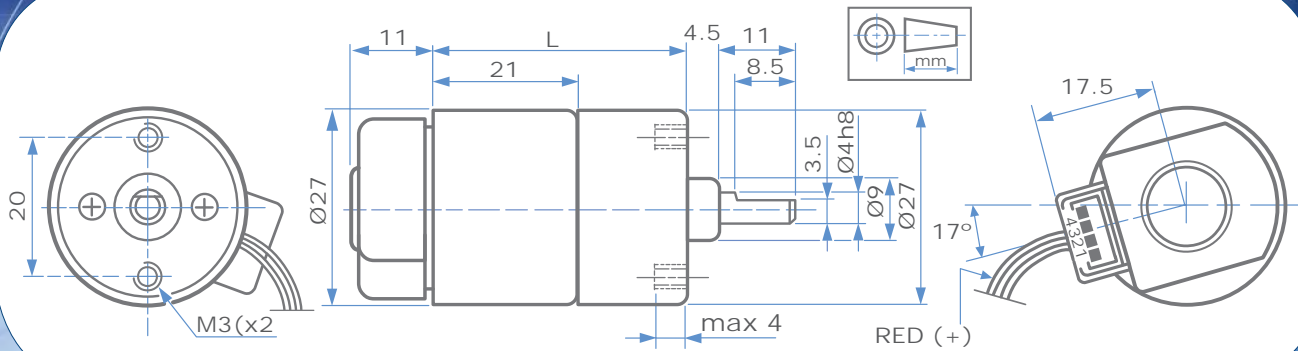

L = See: Series 1271



gear-motors with Hall-effect encoder

1271-E

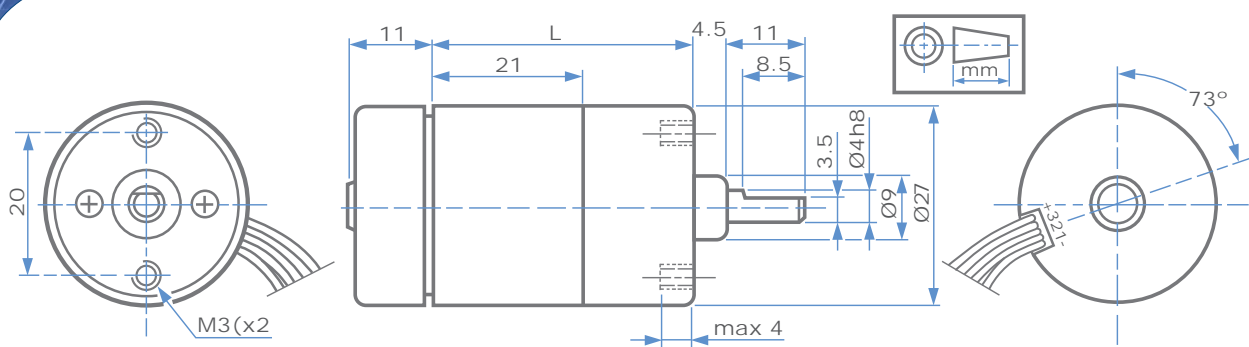

L = See: Series 1271





gear-motors with two-phase Hall-effect 90° encoder

BS138F-2S

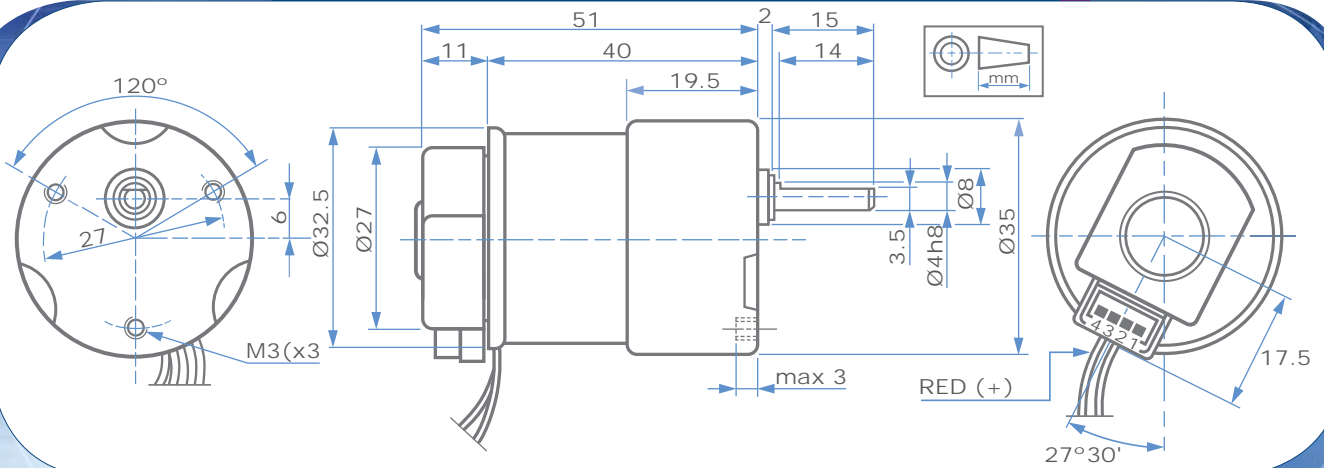

gear-motors with Hall-effect encoder

BSE138F

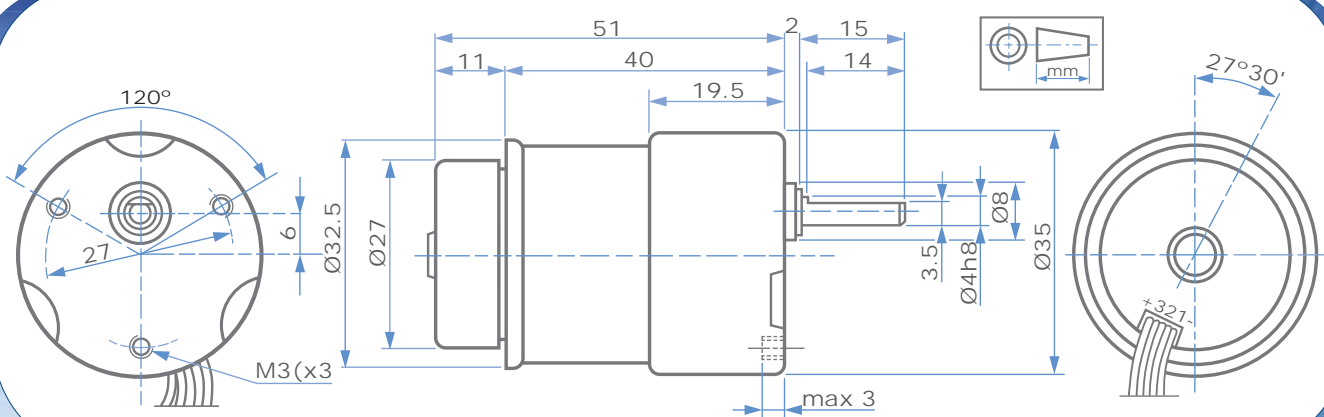



gear-motors with two-phase Hall-effect 90° encoder

HL149-2S/HV155-2S

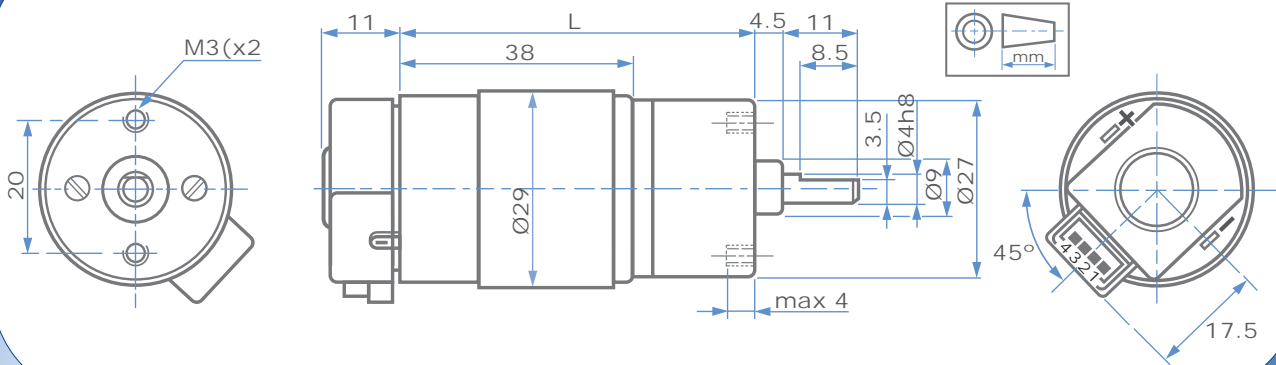

L = See: Series HL149 - HV155



gear-motors with Hall-effect encoder

HLE149/HVE155

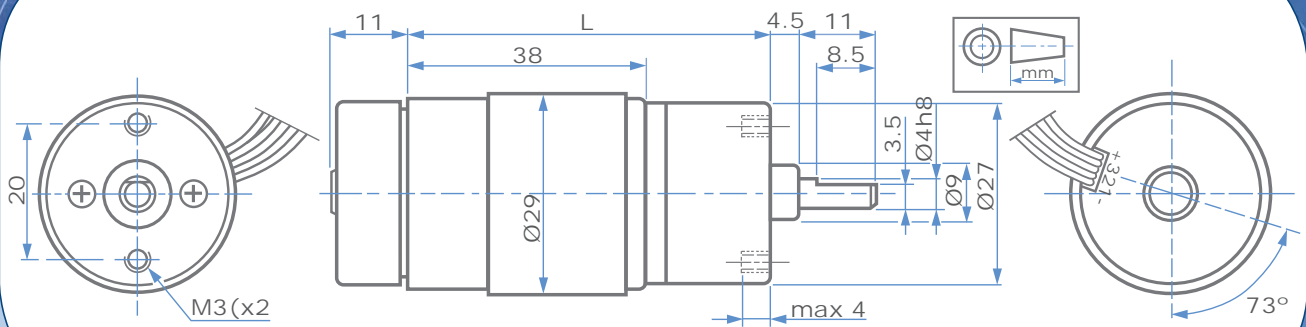

L = See: Series HL149 - HV155

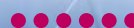



gear-motors with two-phase Hall-effect 90° encoder

1308-2S

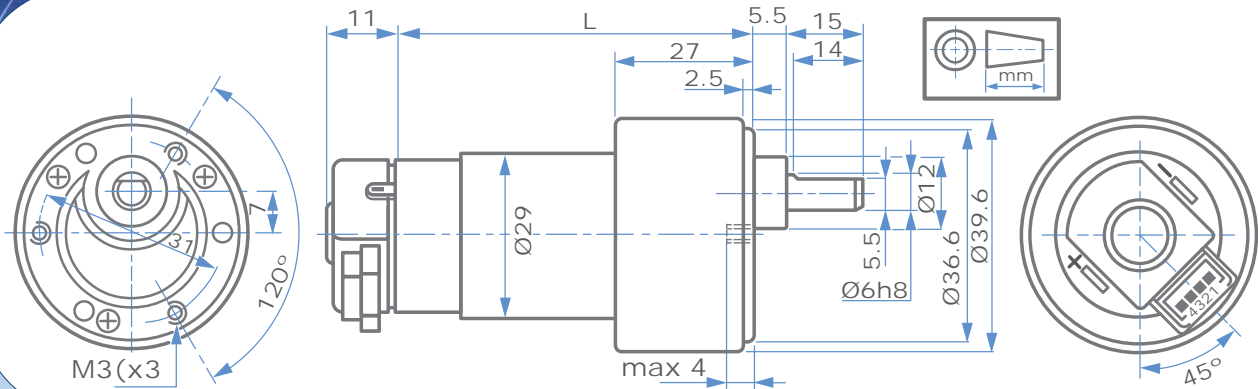

L = See: Series - 1308



gear-motors with Hall-effect encoder

1308E

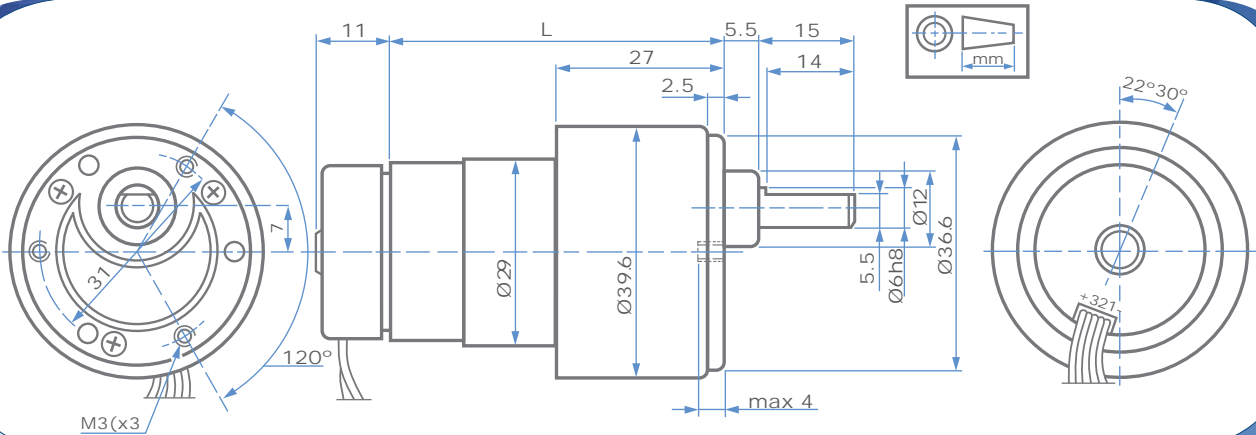

L = See: Series - 1308





gear-motors with two-phase Hall-effect 90° encoder

E192-2S

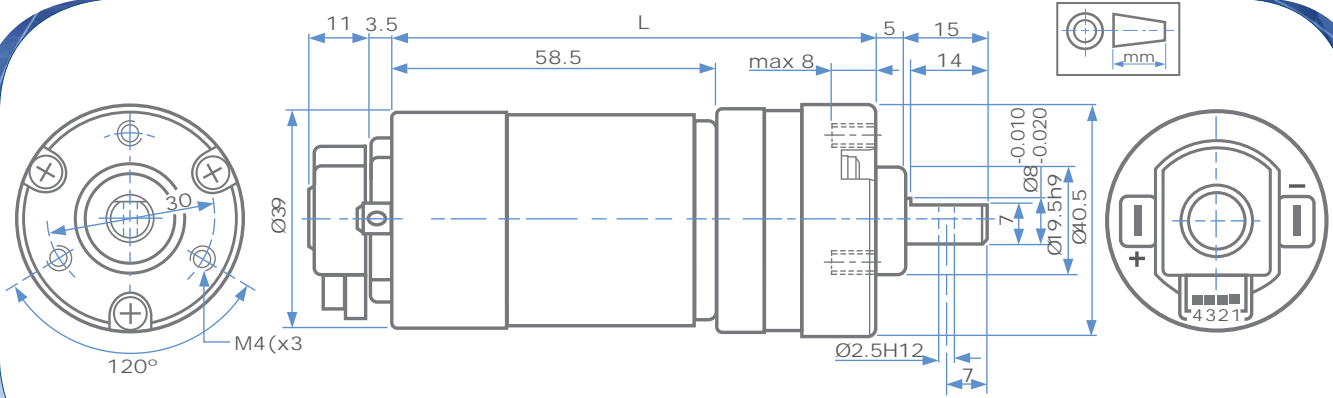

L = See: Series E192



P205-2S

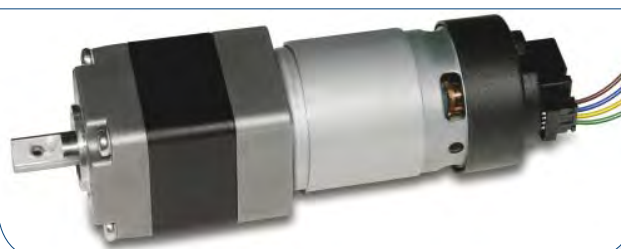
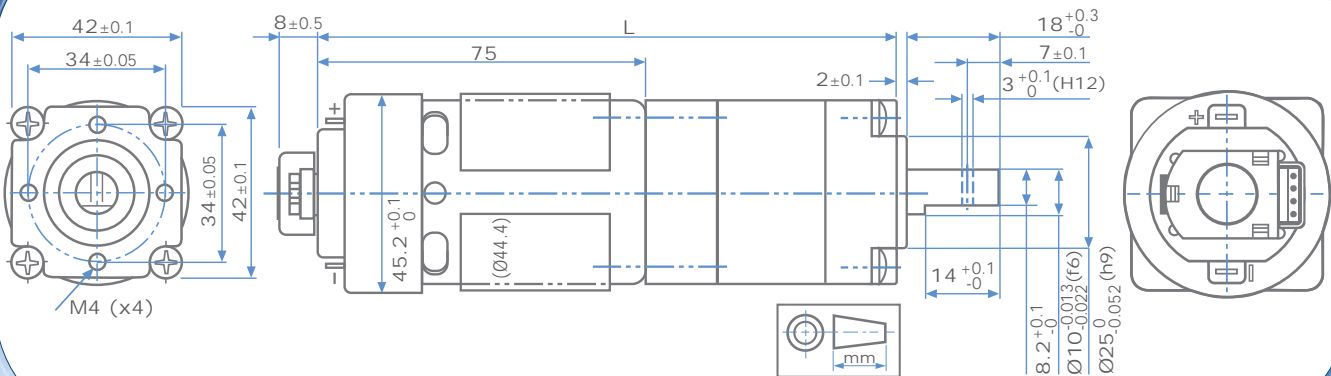

L = See: Series P205

