

CUSTOMIZED

AUTO-BLOQUEO SELF-LOCKING COUPLE D'AUTOBLOCAGE SELBSTHEMMUNG	✓
RUEDA DE BRONCE BRONZE WHEEL ROUE EN BRONZE GETRIEBERAD AUS BRONZE	✓
EJE DELANTERO Y POSTERIOR FRONT AND REAR SHAFT ARBRE ARRIERE VORDERWELLE UND HINTERWELLE	✓
SENSOR HALL HALL SENSOR CAPTEUR HALL HALLSENSOR	✓

Y MUCHO MÁS - AND MANY MORE
ET BEAUCOUP D'AUTRES - UND VIELEN ANDEREN



REFERENCIA REFERENCE NUMBER REFERENZNUMMERN	TENSIÓN NOMINAL NOMINAL VOLTAGE TENSION NOMINALE NENNSPANNUNG	PAR NOMINAL NOMINAL TORQUE COUPLE NOMINAL DREHMOMENT NOMINAL	VELOCIDAD NOMINAL NOMINAL SPEED VITESSE NOMINALE GESCHWINDIGKEIT NOMINAL	CORRIENTE NOMINAL NOMINAL CURRENT COURANT NOMINAL NOMINALSTROM	PAR DE ARRANQUE STARTING TORQUE COUPLE DE DEMARRAGE ANZUGSDREHMOMENT	CORRIENTE DE ARRANQUE STARTING CURRENT COURANT DE DEMARRAGE ANLAUFSTROM	EJE SHAFT ARBRE WELLE	CONEXIONES CONNECTIONS CONNEXIONS ANSCHLUSSART	ESQUEMA ELÉCTRICO WIRING DIAGRAM SCHEMA ÉLECTRIQUE SCHALTBIID	RELACIÓN DE REDUCCIÓN TRANSMISSION RATIO RAPPORT DE REDUCTEUR UNTERSETZUNG	PESO APROXIMADO APPROXIMATE WEIGHT POIDS APPROXIMATIF GEWICHT (ca.)	GRADO DE ESTANQUEIDAD WATERTIGHTNESS ÉTANCHÉITÉ FEUCHTIGKEITSSCHUTZKLASSE	MATERIAL RUEDA WHEEL MATERIAL MATERIAU ROUE MAT. DES SCHNECKENRADES	CURVA CURVE COURBE KURVE
	Un (V)	Mn (N.m./lb.ft.in)	nn (r.p.m.)	In (A)	Ma (N.m./lb.ft.in)	Ia (A)				i	P (kg/lb.t)	IP		
258.1710.20.00	12	15 / 133	25	10	80 / 708	42	E36	C34	F2	52:1	3.00 / 8	IP53	PLA	18
258.1710.30.00	24	15 / 133	25	5	80 / 708	21	E36	C34	F2	52:1	3.00 / 8	IP53	PLA	18
258.3710.20.00	12	15 / 133	25	10	80 / 708	42	E36	C34	EE2	52:1	3.00 / 8	IP53	PLA	18
258.3710.30.00	24	15 / 133	25	5	80 / 708	21	E36	C34	EE2	52:1	3.00 / 8	IP53	PLA	18
258.3712.20.00	12	12 / 106	40	12	80 / 708	55	E36	C34	EE2	52:1	3.00 / 8	IP53	PLA	19
258.3712.30.00	24	12 / 106	40	6	80 / 708	32	E36	C34	EE2	52:1	3.00 / 8	IP53	PLA	19
258.9026.20.00	12	12 / 106	40	12	80 / 708	55	E36	C34	EE2	52:1	3.00 / 8	IP53	CEL	19
258.9026.30.00	24	12 / 106	40	6	80 / 708	32	E36	C34	EE2	52:1	3.00 / 8	IP53	CEL	19

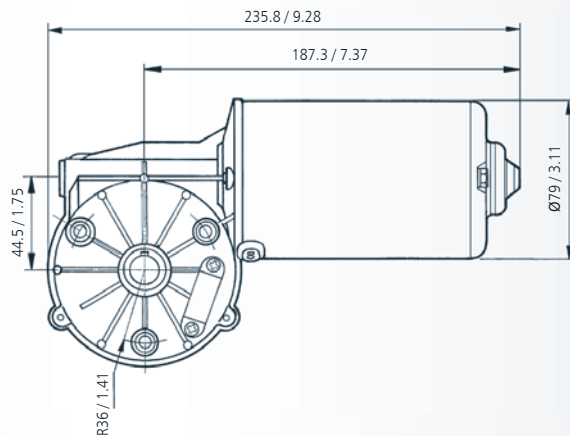
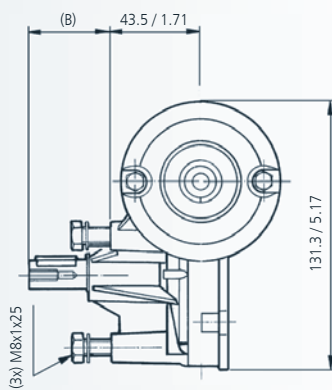

EJE - SHAFT - ARBRE - WELLE

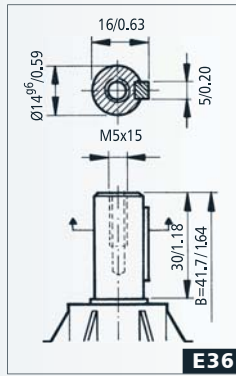

CONEXIONES - CONNECTIONS - CONNEXIONS - ANSCHLUSSART

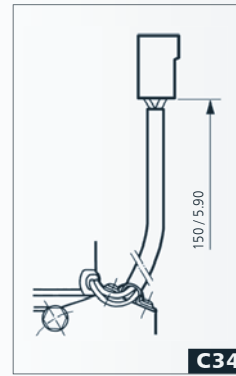

ESQUEMA ELÉCTRICO - WIRING DIAGRAM - SCHÉME ÉLECTRIQUE - SCHALTBIKD

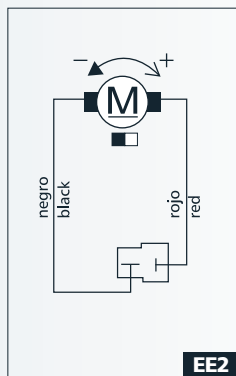

CURVAS - CURVES - COURBES - KURVEN

