

Operating & Maintenance Instructions

Hot Wire Strip Heater 500 / 920

Table of Contents

1. Introduction	2
2. Health & Safety Information	3
3. Machine Parts & Functions	4
4. Electrical Supply & Connection	5
5. Machine Operation	6
6. Maintenance.....	8
7. Connection Diagram	9

1. Introduction

Your new machine is designed to locally heat thermoplastic sheet materials of thicknesses between (typically) 0.5mm and 6.0mm.

The machine operates by heating a thin (0.9mm) diameter resistance wire, which is located in a channel beneath the material. The wire sits approximately 4mm below the material, and there is no contact between wire and work.

The heating wire is powered from a toroidal transformer and operates at approximately 10 volts. The wire is guarded to prevent accidental touching of the heated part.

A calibrated scale on each side of the working area assists the operator with both alignment and measurement of the bend position.



2. Health & Safety Information

General

This Hot Wire Strip Heater is designed for the heating of thermoplastic materials of between 0.5mm (0.020") and 6.0mm (0.250"). The machine should not be used for the heating of any other materials.

Further Information

Should you wish to know more about the Health and Safety of this product, relevant publications are available from the following organisations:

School Science Service
Brunel University
Uxbridge
UB8 3PH
UK

Publishers of

"Risk Assessment for Technology in Secondary Schools"

British Standards Institute
389 Chiswick High Road
London
W4 4AL

Publishers of BS4163:2000

"Health & Safety for Design & Technology in Schools and similar establishments - Code of Practice"

3. Machine Parts & Functions

Your new machine will reach you fully assembled. Carefully unpack the machine and check for any signs of transit damage. These should be reported to the manufacturer or their distributor within three days of receipt.

Machine Parts (Refer also to Diagram 2 below)

- | | | |
|----|--|---|
| 1. | Mains Cable Socket
(On Rear of Machine) | Connect the Mains Cable into the IEC Socket |
| 2. | Mains Available Neon | Illuminates when the machine is connected to the electrical supply. |
| 3. | Mains On / Off Switch | I = On
O = Off |
| 4. | Circuit Breaker
Primary | Protects against overload - pops out when tripped
Push in to Reset |
| 5. | Circuit Breaker
Secondary | Protects against overload - pops out when tripped
Push in to Reset |

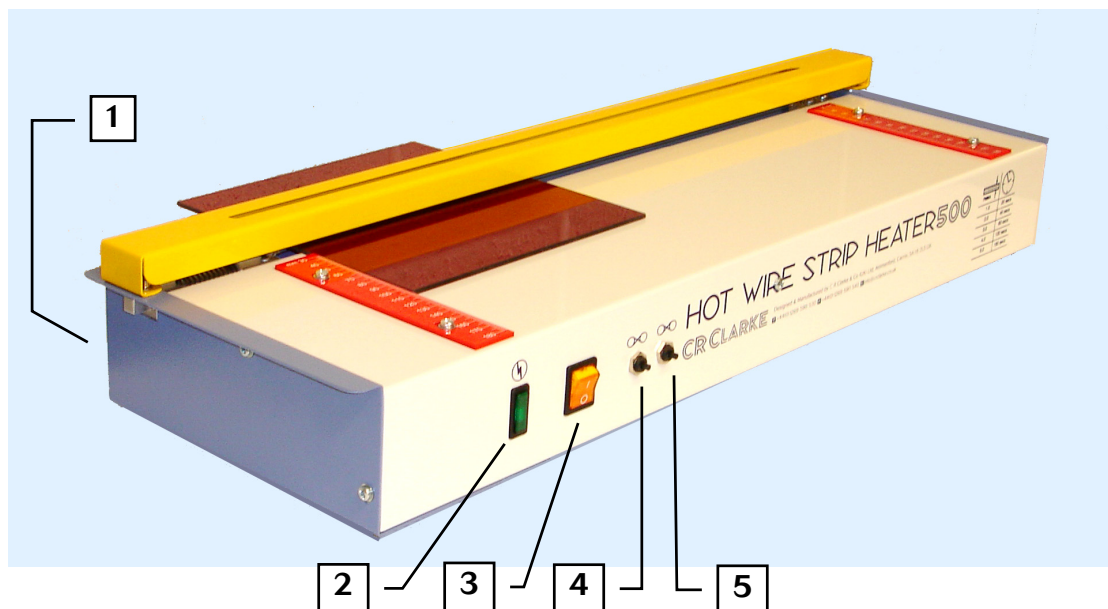

4. Electrical Supply & Connection

The electrical specification of your new machine is as follows:-

	500	920
Voltage (230V machines)	220/240AC	50-60Hz
Voltage (115V machines)	110/120AC	50-60Hz
Current 230V machines)	0.32A	0.6A
Current (115V machines)	0.64A	1.2A
Watts (max)	75W	144W

Electrical supply to the machine must be in accordance with the details shown on the rating label. As the colours of the wires in this mains lead may not correspond with the coloured markings identified in your plug appliance, should the plug need to be changed proceed as follows:-

The wire which is coloured green and yellow must be connected to the terminal which is marked with the letter E or by the earth symbol or coloured green and yellow or green.

The wire which is coloured blue must be connected to the terminal which is marked with the letter N or coloured blue or black.

The wire which is coloured brown must be connected to the terminal which is marked with the letter L or coloured brown or red.

Should there be any queries regarding the electrical requirements of this product please refer back to the manufacturer or their nominated distributor.

5. Machine Operation

1. Load the Material by sliding it beneath the guard.

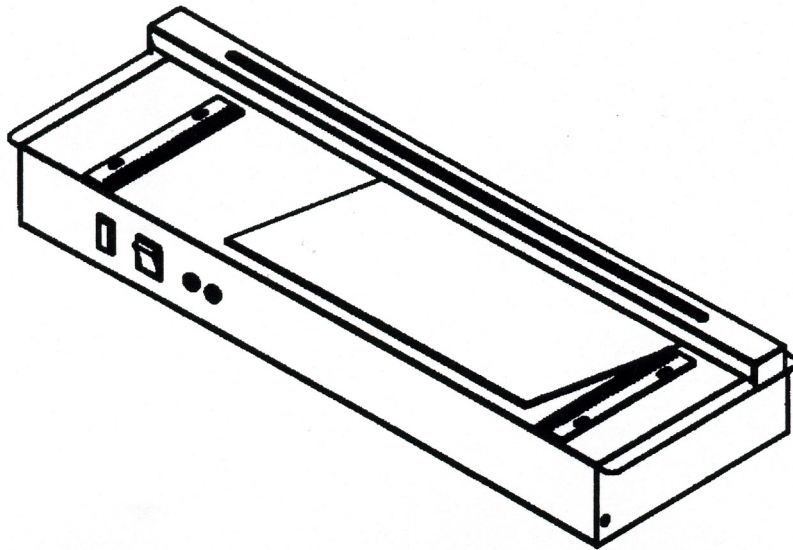

2. Adjust the material to the required position using the calibrated scales or by viewing down through the slot in the guard. Switch on the machine and heat material until flexible.

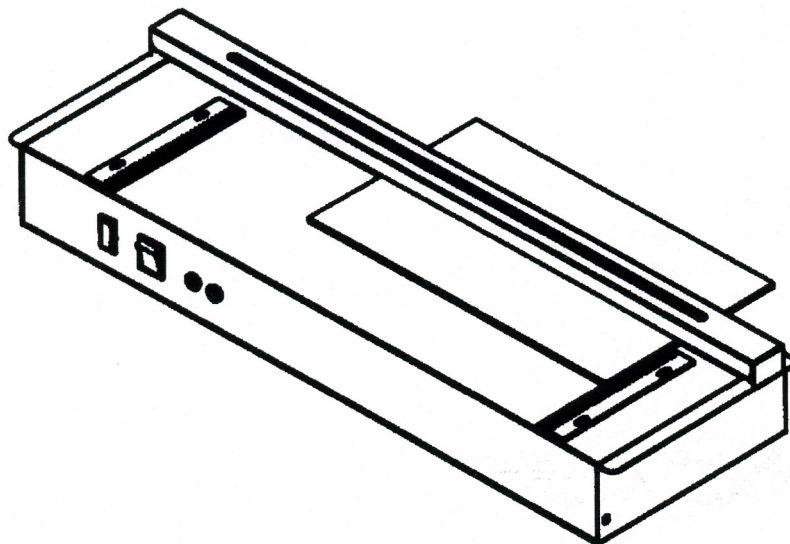

3. Remove the material from the machine.

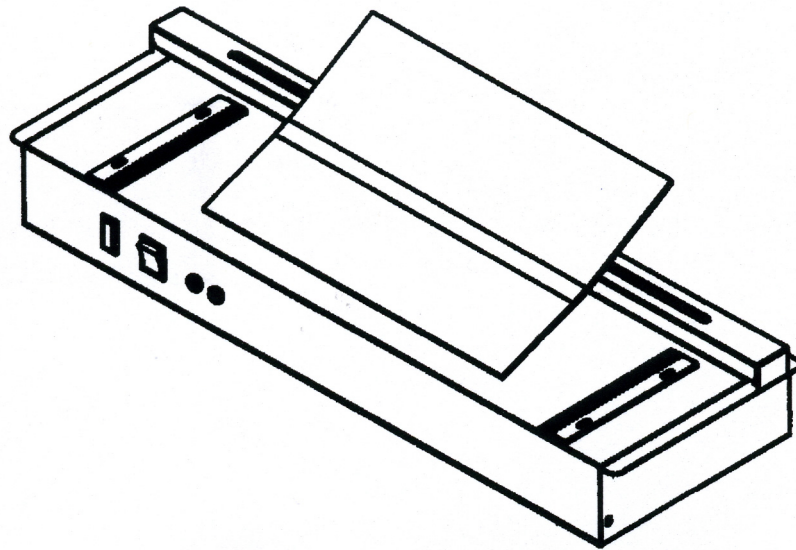

4. Fold by hand or into a cooling jig and allow to cool.

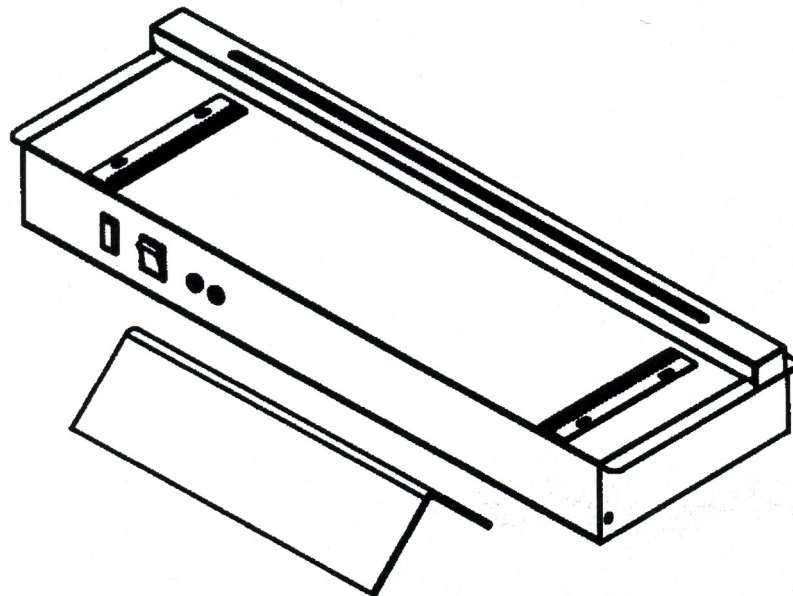

6. Maintenance

Changing a Heating Wire

Disconnect the machine from the electrical supply.
 Remove the four guard securing screws (1), and lift the guard off.
 Push in the tensioning bar (3), and lift off heating wire.
 Lift off wire at other end (4).
 Fit the new wire over locating pin (5).
 Push in tensioning bar (3), and fit the wire over locating pin.
 Replace guard.

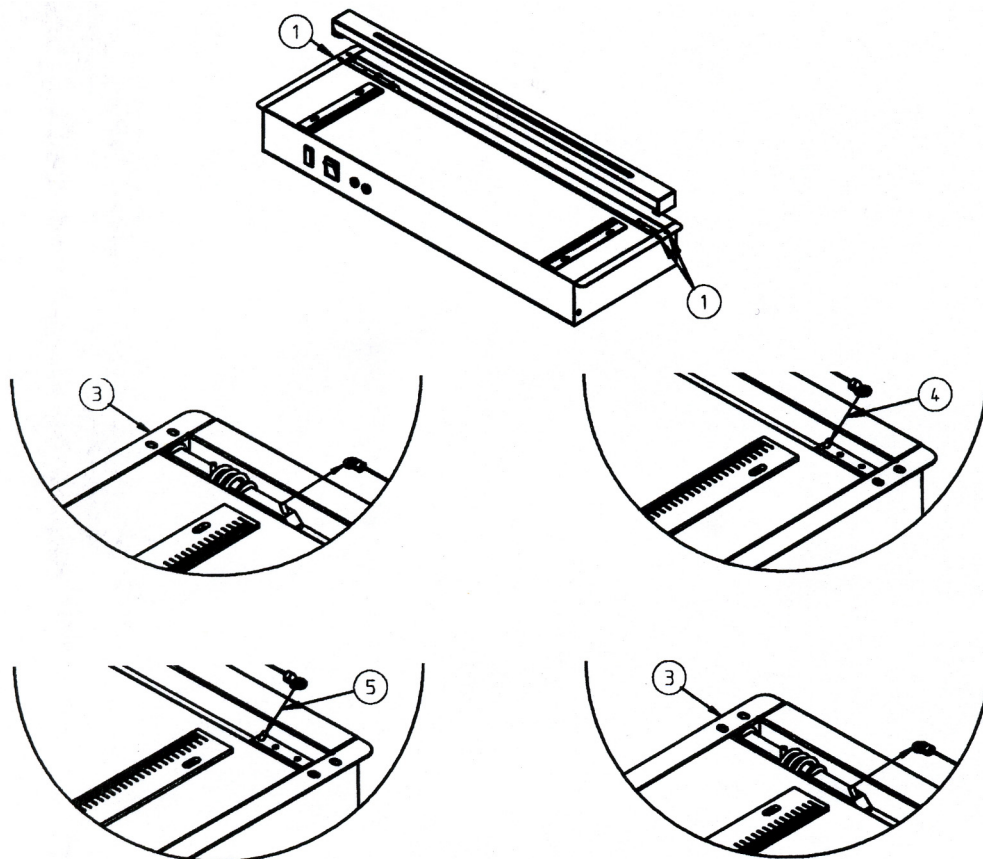

Note: during manufacture, washers may be fitted onto the wire locating pins to adjust the wire height. If fitted, these should be left in position below the heating wire terminals.

Replacement Wire Part Numbers are as follows:

	500	920
Part No	500/99	920/99

Please retain these instructions for future reference. Should there be any other problems or queries regarding your machine please refer back to the manufacturer or their nominated distributor.

7. Connection Diagram

