

INSTALLATION INSTRUCTIONS - NOTICE D'INSTALLATION
 NOTICIA DE INSTALACIÓN - INSTALLATIONSHINWEISE
 ISTRUZIONI PER L'INSTALLAZIONE
 INSTRUCOES DE INSTALACAO - MONTÁŽNÍ NÁVOD
 РУКОВОДСТВО ПО МОНТАЖУ - 安装指导书

DC Surge protector for photovoltaic
 Parafoudre pour Photovoltaïque
 Protecções Fotovoltaica
 Überspannungsschutz für Photovoltaik
 Scaricatori da sovratensioni per impianto fotovoltaico
 Protecção contra surtos de energia fotovoltaica

Configurations (1, 2, 3 or 4):

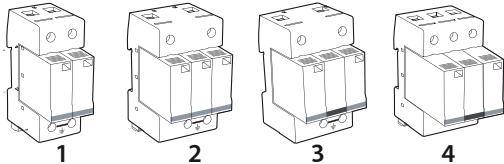

DS50PVxx-xxx (/51)series
 DS50GVPVxx-xxx (/51)series

Technical Data

2000 m max. 6500 ft max. -40/+85°C max. -40/+185°F max. IP20 when fully installed indoor use only Humidity range 5% - 95%	<i>P/N</i>																			
	DS50PV(S)-500	DS50PV(S)-600	DS50PV(S)-800	DS50PV(S)-1000	DS50PV(S)-1000/51	DS50PV(S)-500/G	DS50PV(S)-800/G	DS50PV(S)-1000/G	DS50PV(S)-500/51	DS50PV(S)-600/51	DS50PV(S)-500G/51	DS50PV(S)-600G/51	DS50PV(S)-800G/51	DS50PV(S)-1000G/51	DS50GVPV(S)-500	DS50GVPV(S)-1000	DS50GVPV(S)-600G/51	DS50GVPV(S)-1000G/51	DS50GVPV(S)-1500G/51	
PV Network (Uocsc)																				
500	Vdc	●							●											
600	Vdc		●							●										
800	Vdc			●							●									
1000	Vdc				●	●								●		●				
1250	Vdc																		●	
Characteristics																				
Configurations (see drawing)		1	1	2	2	2	3	3	3	1	1	3	3	3	3	2	2	4	4	
Port configuration		1 - port SPD																		
I_{scpv}		70 A									1000 A									
I_{PE} (AC and DC)		< 1 mA / (< 1 µA for G and VG version)																		
I_{max}		40 kA																		
I_{total}		60 kA																		
SPD overload behaviour mode		Open Circuit Mode (OCM)																		
SCCR at Uocsc-Fuseless (kAIC)*		NA	NA	NA	50	NA	NA	NA	NA	NA	NA	NA	NA	NA	100	50	NA	NA	NA	

Remote signal option: S: e.g DS50PV_S-500
 * Following UL1449

Table 1

Installation

	min-max ∅	
	2.5 - 35 mm ²	13 - 2 AWG
	2.5 - 25 mm ²	13 - 4 AWG

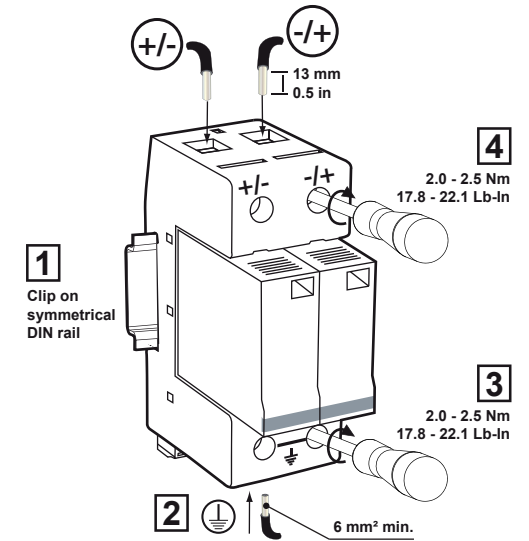

Wiring

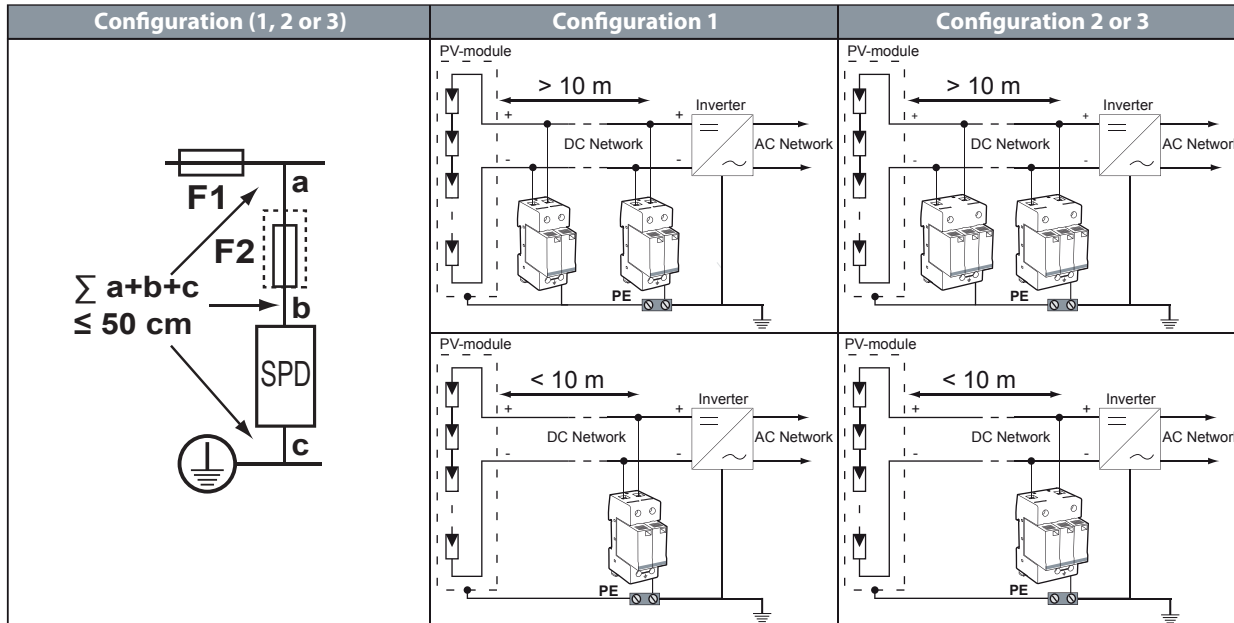
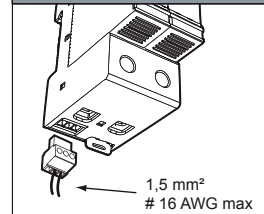

Table 2

Remote contact wiring



2.1 Lb-In
 0.5 Nm max.
 250 Vac / 0.5 A max.
 30 Vdc / 3 A max.

Remote signal for disconnection information

11-12 Closed = SPD OK
 11-14 Open = SPD OK
 11-12 Open = SPD disconnect
 11-14 Closed = SPD disconnect

Table 3

Maintenance

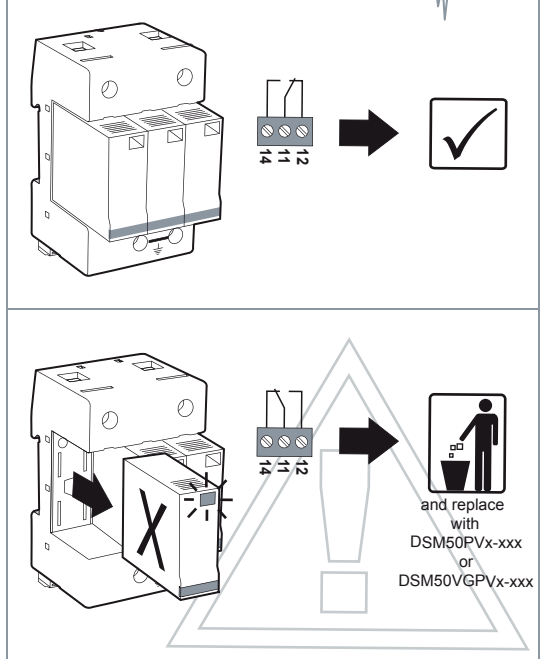



CITEL

SAFETY INSTRUCTIONS
 CONSIGNES DE SECURITE
 SICHERHEITSHINWEISE
 ADVERTENCIA DE SEGURIDAD
 AVVERTENZE IMPORTANTI
 AVISOS IMPORTANTES
 МЕРЫ БЕЗОПАСНОСТИ
 BEZPEČNOSTNÍ POKYNY

安全須知



*This document could be modified without notice.
 Updated Information on Website.*

*Ce document peut être modifié sans préavis.
 Informations à jour sur site web.*

*Änderungen am Dokument ohne Ankündigung möglich.
 Aktuelle Informationen finden Sie auf unserer Webseite.*

*Este documento puede ser modificado sin previo aviso.
 Información actualizada en el sitio web.*

*Questo documento può essere modificato senza preavviso.
 Informazioni attualizzate disponibili sul sito web.*

*Este documento pode ser modificado sem aviso prévio.
 Informação atualizada no website.*

*В документ могут вноситься изменения.
 Актуальную информацию смотрите на нашей
 WEB-странице.*

*Změny v tomto dokumentu jsou možné bez předchozího
 upozornění.*

Aktuální informace najdete na naší webové stránce.

*本文件的修改恕不另行通知。
 查看最新文件请登陆公司网站。*

www.citel2cp.com
www.citel.de
www.citel.us
www.citel.com.cn
www.citel.ru
www.citel.cz



ATTENTION !

GB

- Installation must be performed only by electrically skilled operator.
- National electrical installation rules must be followed.
- The unit must be used only as surge protector and according the conditions described in this document.
- Surge protectors must be selected in relation with an dedicated network.
- In case of red indicator, the surge protector must be replaced.



ATTENTION !

FR

- L'installation ne doit être effectuée que par un opérateur électricien dûment qualifié.
- Les règles générales d'installation électrique nationales doivent être respectées.
- Le produit est uniquement destiné à un usage parafoudre et doit être utilisé dans les conditions décrites dans ce document.
- Les parafoudres sont utilisés en fonction d'un réseau déterminé.
- En cas d'indicateur passant au rouge, le parafoudre doit être remplacé.



WARNING !

D

- Die Montage und der Anschluss des Gerätes dürfen nur durch eine Elektrofachkraft durchgeführt werden.
- Nationale Installations Vorschriften sind zu beachten.
- Das Gerät ist nur im Rahmen dieser Installationshilfe und seiner technischen Daten zu verwenden.
- Die Ableiter sind nach der max. Spannung auszuwählen (siehe Tabelle 1).
- Ist die Anzeige im Sichtfenster auf ROT umgeschaltet, so ist das Modul DEFECT und muss ausgetauscht werden.



ATENCIÓN !

ES

- Solo un operador eléctrico capacitado puede realizar la instalación.
- Las reglas generales nacionales de instalación eléctrica deben ser respetadas.
- El producto solo tiene un uso de protección contra sobretensiones transitorias y debe ser utilizado en las condiciones mencionadas en este documento.
- Las protecciones contra sobretensiones transitorias se usan en relación con una red determinada.
- Se debe sustituir la protección cuando el indicador esta puesto en rojo.



ATTENZIONE !

IT

- L'installazione deve essere fatta solamente da elettricisti qualificati.
- Devono essere rispettate le regolamentazioni nazionali e locali riguardanti l'installazione di apparati elettrici.
- L'unità deve essere usata solo come protezione da sovratensioni e secondo le condizioni descritte in questo documento.
- Le protezioni da sovratensione devono essere scelte in funzione della corrente alternata di rete (vedere la tabella 1).
- Nel caso in cui si accenda l'indicatore rosso, l'unità di protezione da sovratensione deve essere sostituita.



AVISO !

PT

- A instalação deve ser feita por um electricista habilitado.
- Devem ser seguidas todas as regras de segurança indicadas pelo operador eléctrico.
- Esta protecção deve ser utilizada apenas como protecção contra sobretensões e de acordo com as condições mencionadas neste documento.
- A protecção deve ser escolhida de acordo com a rede eléctrica AC (ver quadro 1).
- Caso o indicador vermelho esteja activo, dever-se-á substituir a protecção.



ВНИМАНИЕ!

RUS

- монтаж и подключение изделия должны производиться только специалистами-электриками.
- необходимо учитывать требования местных норм и стандартов.
- изделие может использоваться только для защиты от импульсных перенапряжений в соответствии с настоящей инструкцией.
- параметры сети должны соответствовать характеристикам изделия.
- при обнаружении индикатора состояния красного цвета изделие должно быть заменено.



VAROVÁNÍ

CZ

- Montáž a připojení svodiče přepětí smí provádět pouze pracovník s příslušnou elektrotechnickou kvalifikací.
- Je zapotřebí dodržovat zásady bezpečnosti práce i platné národní elektrotechnické předpisy.
- Svodič přepětí se smí používat pouze v souladu se svými technickými parametry a podle těchto montážních pokynů.
- Svodiče přepětí je zapotřebí zvolit a používat tak, aby odpovídaly napájecí síti (viz tabulka 1).
- Pokud ukazatel správné funkce má ČERVENOU barvu, pak svodič/modul je VADNÝ a musí být vyměněn.



安全須知!

中文

- 产品安装只能由具备专业资质的人员实施；
- 请遵守国家电气安装相关规范；
- 本产品仅作为浪涌保护器且在本文件所规定的条件下使用；
- 请根据不同的电源网络制式选用浪涌保护器，参见 Table 1；
- 当状态指示变为红色时，须及时更换浪涌保护器；