

EXTECH[®]

USER MANUAL

5 in 1 Environmental Meter Model EN300

**Anemometer
Humidity Meter
Light Meter
Thermometer
Sound Level Meter**

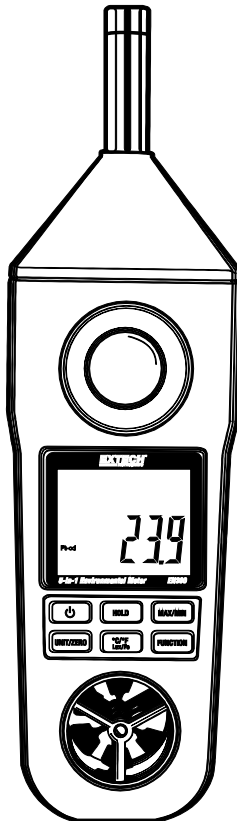

CE

Introduction

Congratulations on your purchase of the Extech EN300. The EN300 is five professional meters built into one convenient package. This meter ships fully tested and calibrated and, with proper use, will provide years of reliable service.

Features:

This 5-in-1 professional meter uses the following measurement technology:

1. Anemometer uses a low-friction ball bearing mounted wheel for high accuracy.
2. Humidity meter uses a high precision humidity sensor for fast response time.
3. Light meter uses a photo diode sensor with color correction filter; spectrum meets C.I.E. photopic.
4. Type K thermometer uses a standard type K (NiCr-NiAl) thermocouple.
5. Sound level meter meets IEC 61672 class 2 with "A" frequency weighting and "Fast" time response.

Common Features:

- Built-in microprocessor circuit assures excellent performance and accuracy.
- Concise and compact button arrangement for easy operation.
- Record maximum and minimum readings.
- Hold function freezes the displayed reading.
- Front panel °C / °F selection button.
- Front panel Lux/Foot-candle selection button.
- Five (5) air velocity measurement units, selected by front panel button.
- Dual display with simultaneous display of relative humidity and temperature or air velocity and temperature.
- Zero button for light meter.
- Rugged housing suitable for one hand operation.

Safety

International Safety Symbols



This symbol, adjacent to another symbol or terminal, indicates the user must refer to the manual for further information.



Double insulation

Warning and Caution

- Improper use of this meter can cause damage, shock, injury, or death. Read and understand this user manual before operating the meter.
- Inspect the condition of the probe and the meter for damage before operating the meter. Repair damage before use or replace meter.
- If the equipment is used in a manner not specified by the manufacturer, the protection provided by the equipment may be impaired.
- This device is not a toy and must not reach children's hands. It contains hazardous objects as well as small parts that children could swallow. If a child swallows an item, seek emergency medical attention.
- Do not leave batteries and packing material unattended; these can be dangerous to children.
- If the device is going to be unused for an extended length of time, remove the batteries to prevent them from draining or leaking.
- Expired or damaged batteries can cause cauterization on contact with skin. Always use suitable hand protection when handling.
- See that the batteries are not short-circuited. Do not throw batteries into fire.

Meter Description

1. Microphone
2. Light sensor
3. Display (LCD)
4. Hold button
5. Power button
6. Unit / Zero button
7. Air velocity sensor
8. Thermocouple input terminal
9. RS-232 output jack
10. Power adaptor jack
11. MAX-MIN button
12. Function button
13. °C/°F and Lux/Ft-cd button
14. On rear: Battery compartment, tripod mount, and stand

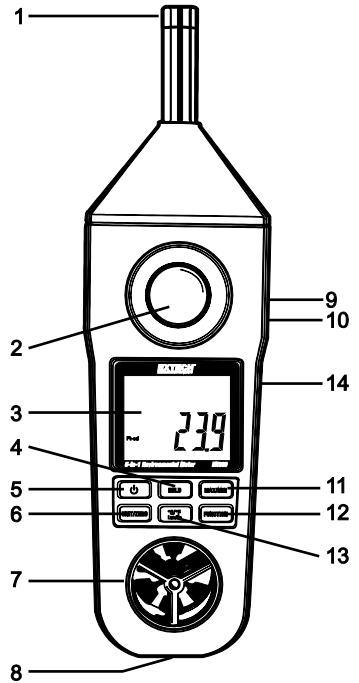

Operation

Powering the meter

1. Press the Power button to switch ON the instrument.
2. If the meter does not switch ON, or if the low battery icon  appears, replace the batteries.
3. Press the Function button to select the desired measurement type.

Note: The display orientation rotates, depending on the function selected.

- Microphone up: Sound, Light, Temperature
- Air speed sensor up: Airspeed + Temperature, Humidity + Temperature

Anemometer Air Velocity Measurement

1. Select the Anemometer function by pressing the Function button until the display indicates air velocity units (ft/min, m/s, km/h, MPH, or knots).
2. Press the Unit/Zero button to select the unit of measure.
3. Press the °C/°F button to select the temperature unit of measure.
4. Face the air velocity sensor into the flow of air.
5. The display will show the air velocity and the ambient temperature measurements.
6. Allow time for the reading to stabilize. Air velocity may fluctuate slightly.

Temperature Measurement (Thermocouple)

1. Plug a type K thermocouple probe into the thermocouple input jack.
2. Select the temperature function using the Function button. The temperature units (°C or °F) will be shown when the temperature function is selected.
3. Touch the thermocouple sensor tip to the object under test.
4. The temperature value will be displayed.

Notes:

- Ensure correct polarity when plugging a thermocouple into the meter.
- A temperature difference between the thermocouple and the meter can result in inaccurate readings. Allow a few minutes for thermal equalization.

Humidity and Ambient Temperature Measurement

1. Select the Relative Humidity function by pressing the Function button until the display indicates %RH.
2. The humidity and temperature readings will be displayed.
3. When the meter is moved to a new location, allow several minutes for temperature stabilization.

Light Measurement

1. Select the Light measurement function by pressing the Function button until a light unit of measure is displayed (Lux or Ft-cd).
2. Press the Lux/Ft-cd button to switch between Lux and Ft-cd units.
3. The Display will show the light value.

Zero Offset calibration for the Light function:

- Before use, zero the light sensor in a dark room. To accomplish this, completely cover the light sensor and press the Unit/Zero button.
- The zero point can drift because of environmental temperature changes and battery voltage drain, check the zero calibration frequently.

Sound Level Measurement

1. Select the Sound Level function by pressing the Function button until the sound unit of measure (dB) is displayed.
2. Hold the instrument in one hand and point the microphone towards the noise source. The sound level value will be displayed.

Changing °C / °F units

During temperature measurements, press the °C / °F button to toggle the units (°C / °F).

Data Hold

Press the Hold button to freeze the current reading, **HOLD** appears on the display. Press the button again to exit this mode.

MAX-MIN Recording

1. The record function captures and displays the maximum and minimum readings. Press the MAX-MIN button to start recording, the **REC** symbol will appear.
2. With the **REC** symbol shown:
 - (a) Press MAX-MIN, the **MAX** symbol and the highest reading will display.
 - (b) Press MAX-MIN, the **MIN** symbol and the lowest reading will display.
 - (c) Long press the MAX-MIN button to exit this mode.
 - (d) While in the MAX-MIN mode, press the Hold button to reset (clear) the recorded readings.

Auto Power OFF

The meter automatically switches OFF after ten (10) minutes of inactivity.

PC Interface (RS232)

The RS232 port is used to transmit measurement data to a PC.

Battery Replacement

1. The low battery icon  appears when the battery voltage is low. Several hours of measurement time are possible after the low battery icon appears.
2. Remove the two battery compartment screws and remove the battery cover.
3. Install six (6) new 1.5 V DC 'AAA' batteries and secure the compartment before use.



You, as the end user, are legally bound (**Battery ordinance**) to return all used batteries and accumulators; **disposal in the household garbage is prohibited!**

You can hand over your used batteries / accumulators at collection points in your community or wherever batteries / accumulators are sold

Disposal: Follow the valid legal stipulations in respect of the disposal of the device at the end of its lifecycle

Specifications

General Specifications

Display	LCD type; 41.5 x 31.5 mm (1.6 x 1.2 in.)
Measurements	Anemometer (Air velocity + Temperature) Humidity (%RH + Temperature) Light Thermometer (type K) Sound level
Operating humidity	80%RH Max.
Operating temperature	0 to 50°C (32 to 122°F)
Over range display	"- - - -"
Data output	RS 232/USB PC serial interface
Power Supply	6 x 1.5 V DC 'AAA' batteries 9 V DC adapter (optional)
Power Consumption	Anemometer: 11 mA DC (approx.) Other functions: 7.5 mA DC (approx.)
Weight	335 g (0.74 lbs.) with batteries
Dimension	(HxWxD) 248 x 70 x 34 mm (9.8 x 2.8 x 1.3 in.)

Electrical Specifications

Anemometer (Air velocity/Temperature)

Units	Range	Res.	Accuracy
ft/min	80 to 5910ft/min	1	≤ 3900ft/min: ± 3% F.S., >3900ft/min: ± 4% F.S.
m/s	0.4 to 30.0m/s	0.1	≤ 20m/s: ± 3% F.S., > 20m/s: ± 4% F.S.
km/h	1.4 to 108.0km/h	0.1	≤ 72km/h: ± 3% F.S., >72km/h: ± 4% F.S.
MPH	0.9 to 67.0mile/h	0.1	≤ 45mile/h: ± 3% F.S., >45mile/h: ± 4% F.S.
knots	0.8 to 58.3 knots	0.1	≤ 39 knots: ± 3% F.S., >39 knots: ± 4% F.S.
°F	32 to 122°F	0.1	± 2.5°F
°C	0 to 50°C	0.1	± 1.2°C

Type K Thermocouple Thermometer

Units	Range	Resolution	Accuracy
°F	-148 to 2372°F	0.1°F	± (1% reading + 2°F)
°C	-100 to 1300°C	0.1°C	± (1% reading + 1°C)

Note: Type K thermocouple probe optional

Hygrometer (Humidity/Temperature)

Units	Range	Resolution	Accuracy
%RH	10 to 95 %RH	0.1 %RH	< 70 %RH: $\pm 4\%$ RH $\geq 70\%$ RH: $\pm (4\% \text{ reading} + 1.2\% \text{ RH})$
°F	32 to 122°F	0.1°F	$\pm 2.5^\circ\text{F}$
°C	0 to 50°C	0.1°C	$\pm 1.2^\circ\text{C}$

Light

Units	Range	Resolution	Accuracy
Lux	0 to 2,200 Lux	1 Lux	$\pm 5\%$ reading ± 8 digits
	1,800 to 20,000 Lux	10 Lux	
Ft-cd	0 to 204.0 Fc	0.1 Ft-cd	
	170 to 1,860 Fc	1 Ft-cd	

Sound Level

Microphone	0.5 in. Electret condenser microphone
Measurement range	35 to 130 dB, Auto range
Resolution	0.1 dB
Frequency response	31.5 Hz to 8,000 Hz
Weighting	'A' frequency weighting
Time response	'Fast'
Accuracy	Meets IEC 61672 class 2, A weight, Fast response

Note: Stated specification tests under the environment RF Field Strength < 3 V/M and frequency < 30 MHz only.

Note: Specification stated for ambient temperature $23^\circ\text{C} \pm 5^\circ\text{C}$ ($73.4^\circ\text{C} \pm 9^\circ\text{F}$).

Two-year Warranty

Teledyne FLIR warrants this Extech brand instrument to be free of defects in parts and workmanship for two years from date of shipment. To view the full warranty text please visit:

<https://www.flir.com/support-center/warranty/instruments/extech-product-warranty/>

Calibration and Repair Services

Teledyne FLIR offers calibration and repair services for the Extech brand products we sell. We offer NIST traceable calibration for most of our products.

Customer Support

Local Telephone Support List: <https://support.flir.com/contact>

Return Material Authorization (RMA): <https://customer.flir.com/Home>

Customer Service: <https://support.flir.com/ContactService>

Technical Support: <https://support.flir.com>

Copyright © 2024 Teledyne FLIR Commercial Systems, Inc.

All rights reserved including the right of reproduction in whole or in part in any form.

www.extech.com

This document does not contain export-controlled information.

