

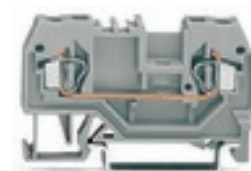

2-conductor through terminal block; 2.5 mm²; center marking; for DIN-rail 35 x 15 and 35 x 7.5; CAGE CLAMP®

Item No.: 280-901



2-conductor through terminal block; 2.5 mm²; center marking; for DIN-rail 35 x 15 and 35 x 7.5; CAGE CLAMP®

Marking

RoHS ✓
Compliant

Business data

Supplier	WAGO
Item no.	280-901
GTIN / EAN	4044918391726
Content	1

Notes

Technical data

Miscellaneous

Ratings per	IEC/EN 60947-7-1
Rated voltage (III / 3) [V]	800 [V]
Rated impulse voltage (III / 3) [kV]	8 [kV]
Rated current [A]	24 [A]
Legend (ratings)	(III / 3) Overvoltage category III / Pollution degree 3
Connection technology	CAGE CLAMP®

Technical data	
<i>Actuation type</i>	<i>Operating tool</i>
<i>Connectable conductor materials</i>	<i>Copper</i>
<i>Solid conductor</i>	<i>0.08 ... 2.5 mm² / 28 ... 12 AWG</i>
<i>Fine-stranded conductor</i>	<i>0.08 ... 2.5 mm² / 28 ... 12 AWG</i>
<i>Strip length</i>	<i>8 ... 9 mm / 0.31 ... 0.35 Inch</i>
<i>Total number of connection points</i>	<i>2</i>
<i>Total number of potentials</i>	<i>1</i>
<i>Number of levels</i>	<i>1</i>
<i>Type of wiring</i>	<i>Front-entry wiring</i>
<i>Note (conductor cross-section)</i>	<i>12 AWG: THHN, THWN</i>
<i>Width</i>	<i>5 mm / 0.197 Inch</i>
<i>Height from upper-edge of DIN-35 rail</i>	<i>28 mm / 1.102 Inch</i>
<i>Depth</i>	<i>53 mm / 2.087 Inch</i>
<i>Design</i>	<i>horizontal</i>
<i>Type of mounting</i>	<i>Carrier rail 35 x 15</i>
<i>Marking level</i>	<i>Center marking</i>
<i>Color</i>	<i>gray</i>
<i>Insulating material</i>	<i>Polyamide 66 (PA 66)</i>
<i>Fire load [MJ]</i>	<i>0.106 [MJ]</i>
<i>Weight [g]</i>	<i>5.3 [g]</i>
<i>Packaging type</i>	<i>BOX</i>
<i>Main product function</i>	<i>Through term. block</i>
<i>Product type</i>	<i>Through rail-mount term. blocks</i>

Images & drawings

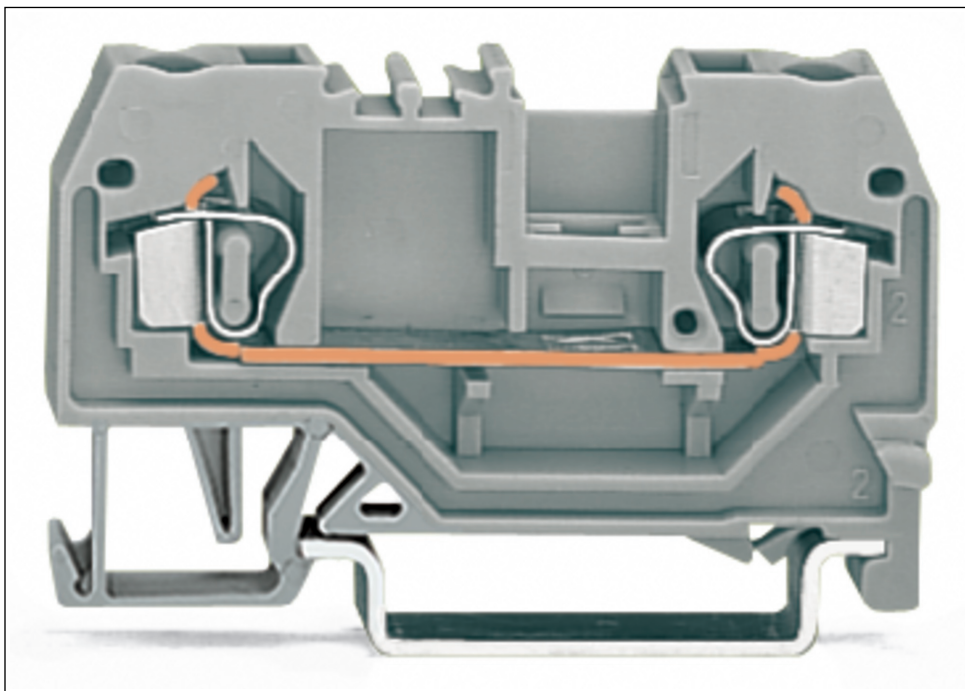
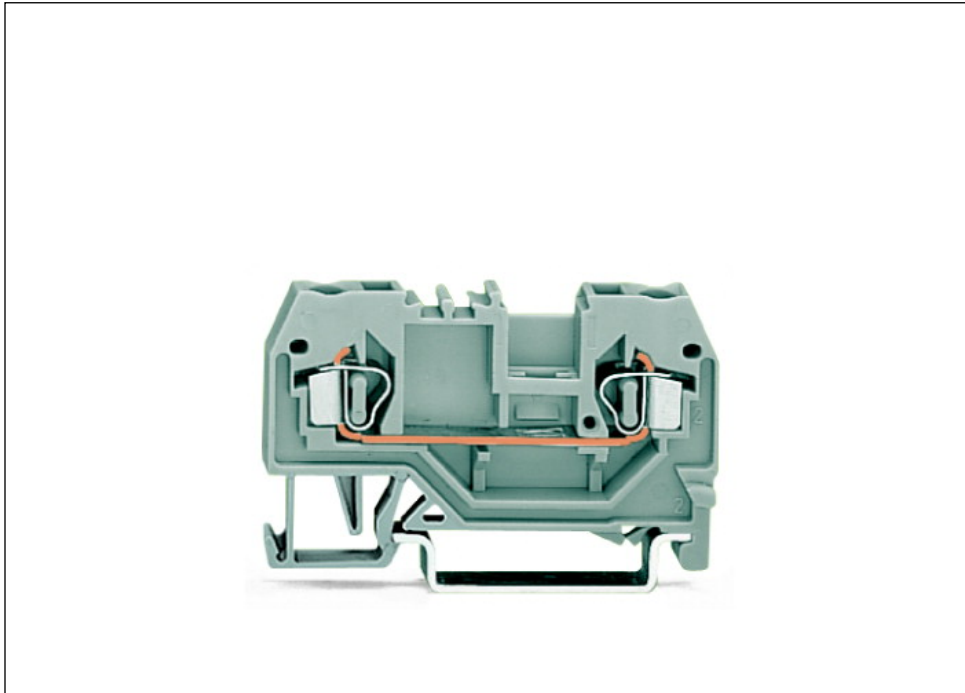

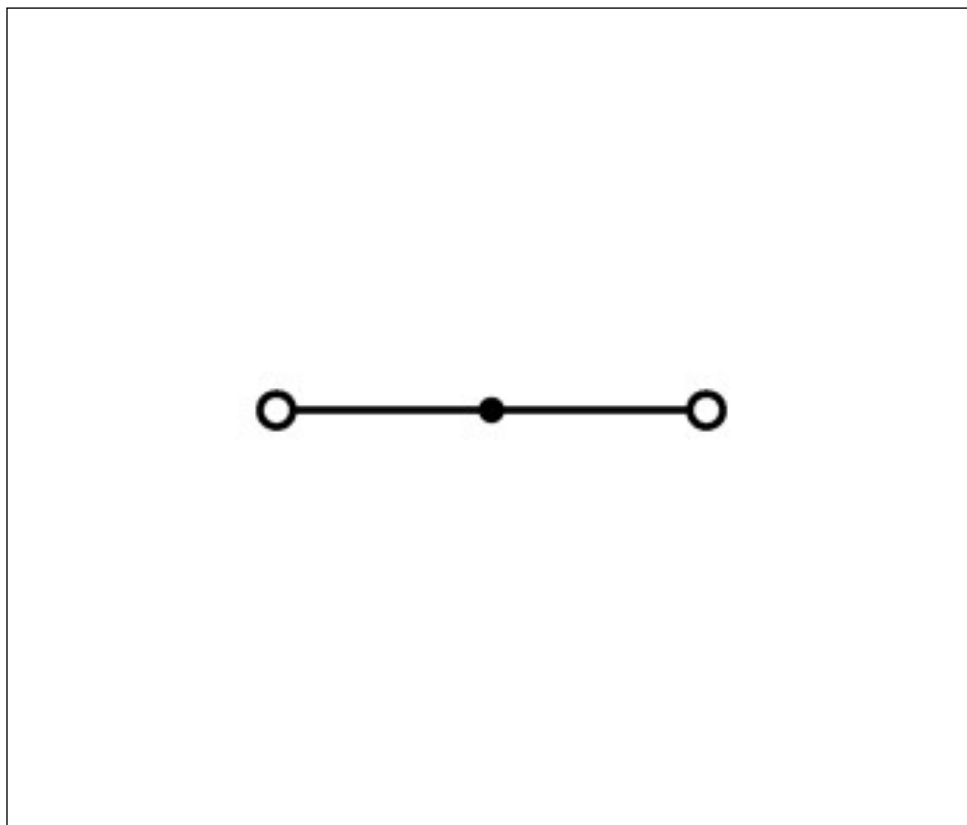
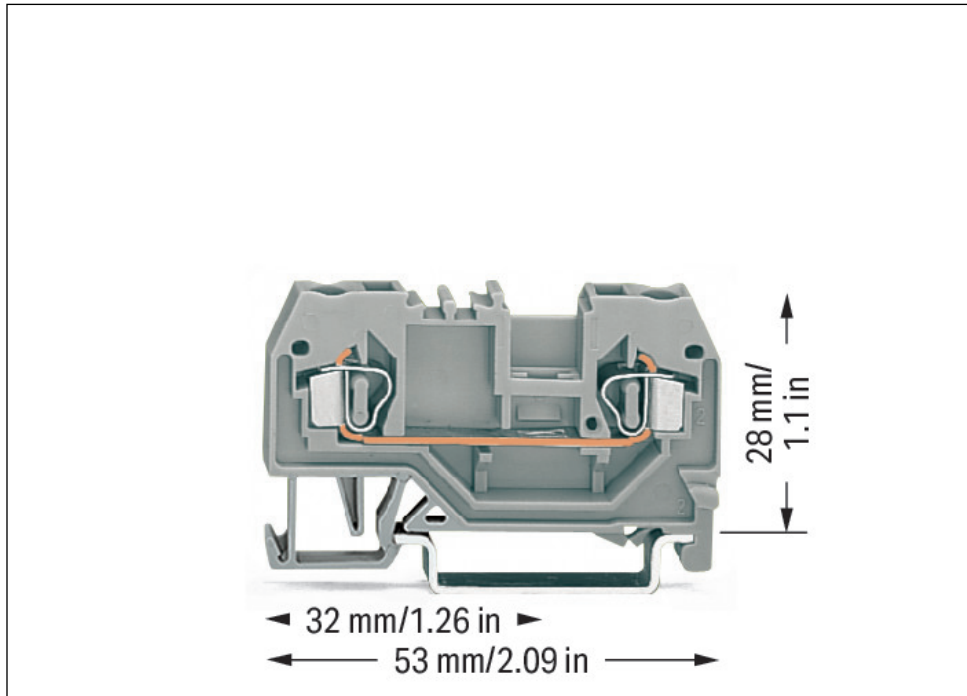

Address

WAGO Kontakttechnik GmbH & Co. KG

Hansastr. 27

32423 Minden

Telefon: 0571/887-0

Fax: 0571/887-169

<http://www.wago.com>

© WAGO Kontakttechnik GmbH & Co. KG

Technische Änderungen und Irrtümer vorbehalten.