



2-conductor ground terminal block; 2.5 mm²; center marking; for DIN-rail 35 x 15 and 35 x 7.5; CAGE CLAMP®

Item No.: 280-907



2-conductor ground terminal block; 2.5 mm²; center marking; for DIN-rail 35 x 15 and 35 x 7.5; CAGE CLAMP®

Marking

RoHS ✓
Compliant

Business data

| | |
|------------|---------------|
| Supplier | WAGO |
| Item no. | 280-907 |
| GTIN / EAN | 4045454100179 |
| Content | 1 |
| | |
| | |

Notes

Technical data

Miscellaneous

| | |
|---------------------------------|--|
| Ratings per | IEC/EN 60947-7-2 |
| Connection technology | CAGE CLAMP® |
| Actuation type | Operating tool |
| Connectable conductor materials | Copper |
| Solid conductor | 0.08 ... 2.5 mm ² / 28 ... 12 AWG |
| Fine-stranded conductor | 0.08 ... 2.5 mm ² / 28 ... 12 AWG |

| Technical data | |
|--|--|
| <i>Strip length</i> | <i>8 ... 9 mm / 0.31 ... 0.35 Inch</i> |
| <i>Total number of connection points</i> | <i>2</i> |
| <i>Total number of potentials</i> | <i>1</i> |
| <i>Number of levels</i> | <i>1</i> |
| <i>Type of wiring</i> | <i>Front-entry wiring</i> |
| <i>Note (conductor cross-section)</i> | <i>12 AWG: THHN, THWN</i> |
| <i>Width</i> | <i>5 mm / 0.197 Inch</i> |
| <i>Height from upper-edge of DIN-35 rail</i> | <i>28 mm / 1.102 Inch</i> |
| <i>Depth</i> | <i>54 mm / 2.126 Inch</i> |
| <i>Design</i> | <i>horizontal</i> |
| <i>Type of mounting</i> | <i>Carrier rail 35 x 15</i> |
| <i>Marking level</i> | <i>Center marking</i> |
| <i>Color</i> | <i>green-yellow</i> |
| <i>Insulating material</i> | <i>Polyamide 66 (PA 66)</i> |
| <i>Fire load [MJ]</i> | <i>0.091 [MJ]</i> |
| <i>Weight [g]</i> | <i>9.21 [g]</i> |
| <i>Packaging type</i> | <i>BOX</i> |
| <i>Main product function</i> | <i>GND cond. term. block</i> |
| <i>Product type</i> | <i>Through rail-mount term. blocks</i> |

Images & drawings

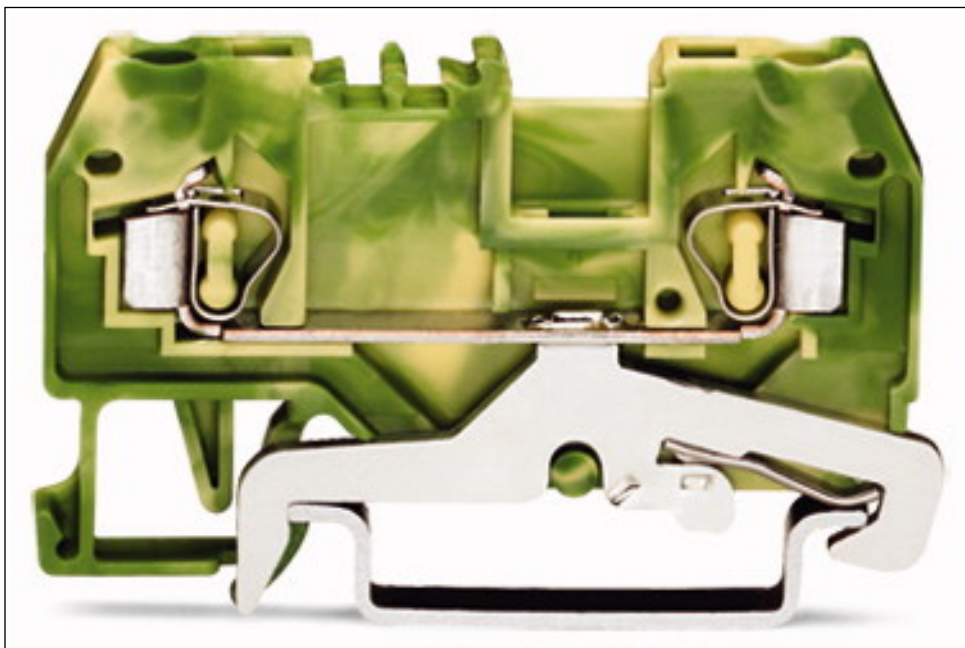

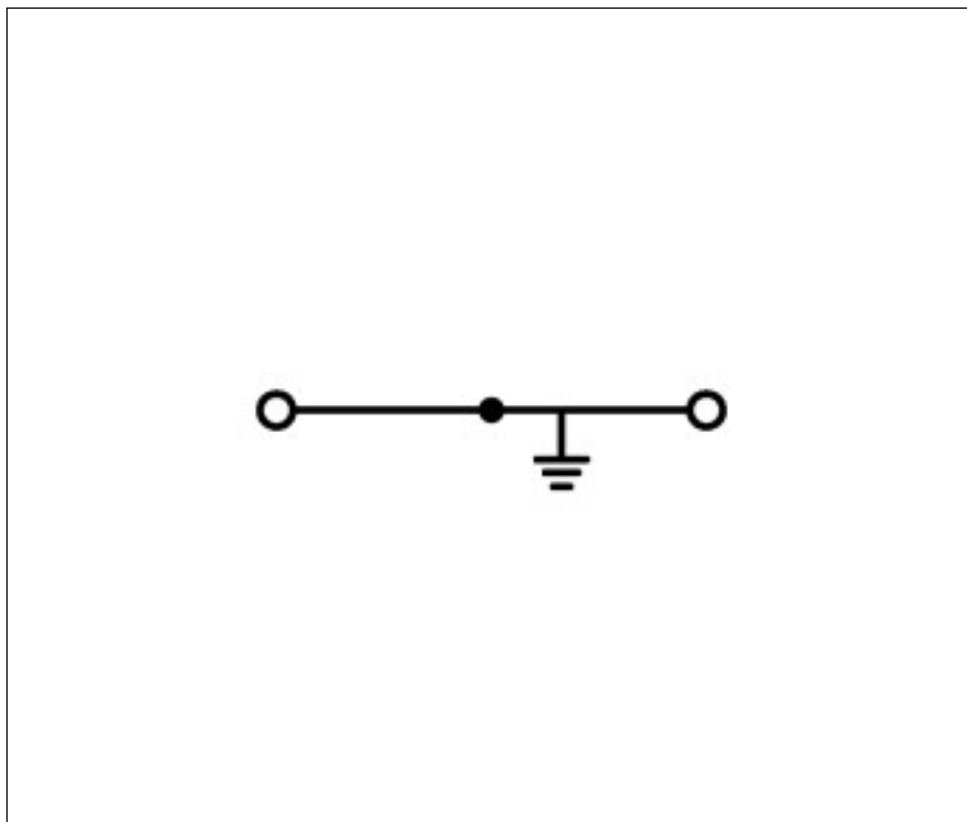
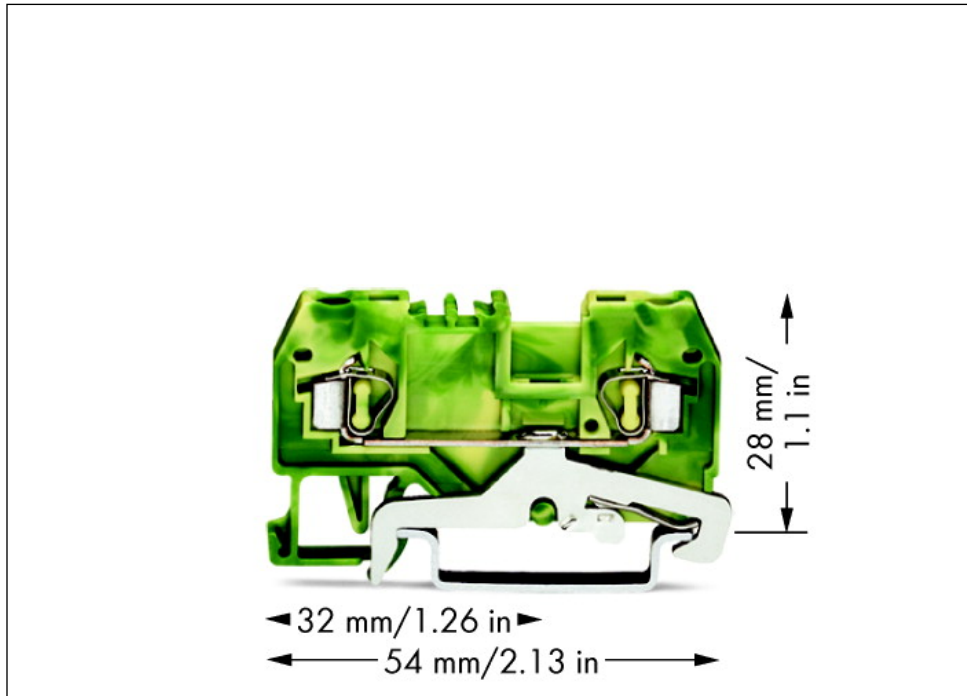

Address

WAGO Kontakttechnik GmbH & Co. KG

Hansastr. 27

32423 Minden

Telefon: 0571/887-0

Fax: 0571/887-169

<http://www.wago.com>

© WAGO Kontakttechnik GmbH & Co. KG

Technische Änderungen und Irrtümer vorbehalten.