



Quadruple-deck rail-mounted terminal block; Rail-mounted terminal block for electric motor wiring; L1 - L2 - L3 - PE; for DIN-rail 35 x 15 and 35 x 7.5; 2.5 mm²; CAGE CLAMP®

Item No.: 281-530



Quadruple-deck rail-mounted terminal block; Rail-mounted terminal block for electric motor wiring; L1 - L2 - L3 - PE; for DIN-rail 35 x 15 and 35 x 7.5; 2.5 mm²; CAGE CLAMP®

Marking

RoHS ✓
Compliant

Business data

Supplier	WAGO
Item no.	281-530
GTIN / EAN	4045454017071
Content	1

Notes

Technical data

Miscellaneous

Ratings per	IEC/EN 60947-7-1
Rated voltage (III / 3) [V]	400 [V]
Rated impulse voltage (III / 3) [kV]	6 [kV]
Rated current [A]	20 [A]
Rated current (2) [A]	25 [A]

Printview: Quadruple-deck rail-mounted terminal block; Rail-mounted terminal block for electric motor wiring; L1 - L2 - L3 - PE; for DIN-rail 35 x 15 and 35 x 7.5; 2.5 mm²; CAGE CLAMP® - Item No.: 281-530

Technical data	
<i>Legend (ratings)</i>	<i>(III / 3) Overvoltage category III / Pollution degree 3</i>
<i>Connection technology</i>	<i>CAGE CLAMP®</i>
<i>Actuation type</i>	<i>Operating tool</i>
<i>Connectable conductor materials</i>	<i>Copper</i>
<i>Nominal cross section</i>	<i>2.5 mm²</i>
<i>Solid conductor</i>	<i>0.08 ... 4 mm² / 28 ... 12 AWG</i>
<i>Fine-stranded conductor</i>	<i>0.08 ... 4 mm² / 28 ... 12 AWG</i>
<i>Strip length</i>	<i>8 ... 9 mm / 0.31 ... 0.35 Inch</i>
<i>Total number of connection points</i>	<i>7</i>
<i>Total number of potentials</i>	<i>4</i>
<i>Number of levels</i>	<i>4</i>
<i>Type of wiring</i>	<i>Front-entry wiring</i>
<i>Width</i>	<i>6 mm / 0.236 Inch</i>
<i>Height from upper-edge of DIN-35 rail</i>	<i>62.5 mm / 2.461 Inch</i>
<i>Depth</i>	<i>100 mm / 3.937 Inch</i>
<i>Design</i>	<i>angled</i>
<i>Type of mounting</i>	<i>Carrier rail 35 x 15</i>
<i>Potential marking</i>	<i>L1 - L2 - L3 - PE</i>
<i>Marking level</i>	<i>Center/side marking</i>
<i>Color</i>	<i>gray</i>
<i>Insulating material</i>	<i>Polyamide 66 (PA 66)</i>
<i>Fire load [MJ]</i>	<i>0.356 [MJ]</i>
<i>Weight [g]</i>	<i>23.221 [g]</i>
<i>Packaging type</i>	<i>BOX</i>
<i>Main product function</i>	<i>Multilevel terminal blocks</i>
<i>Product type</i>	<i>Through rail-mount term. blocks</i>

Images & drawings

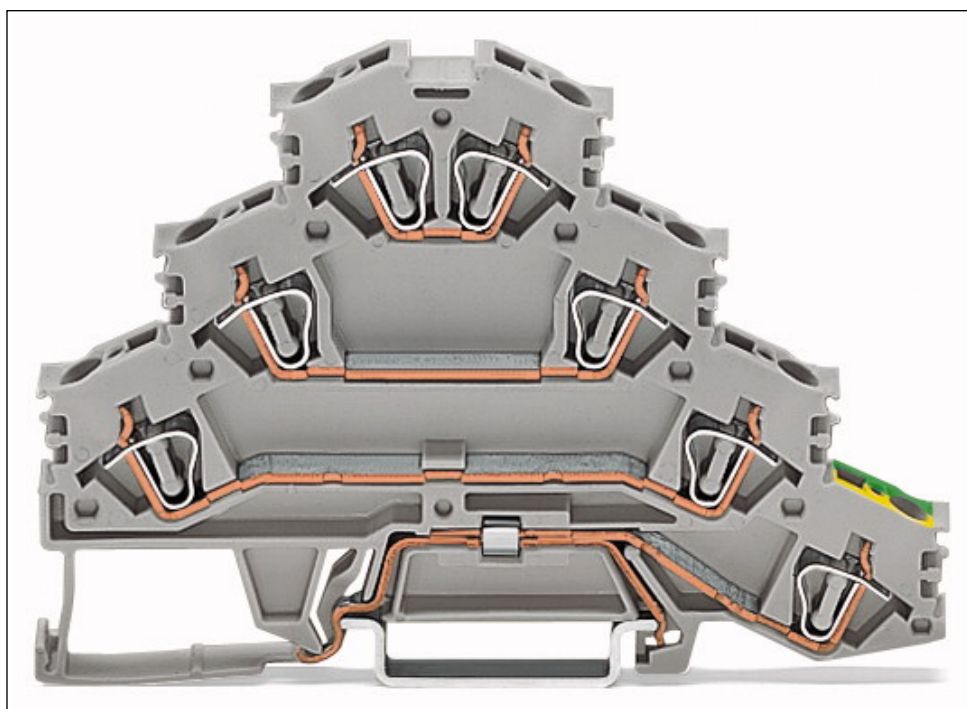
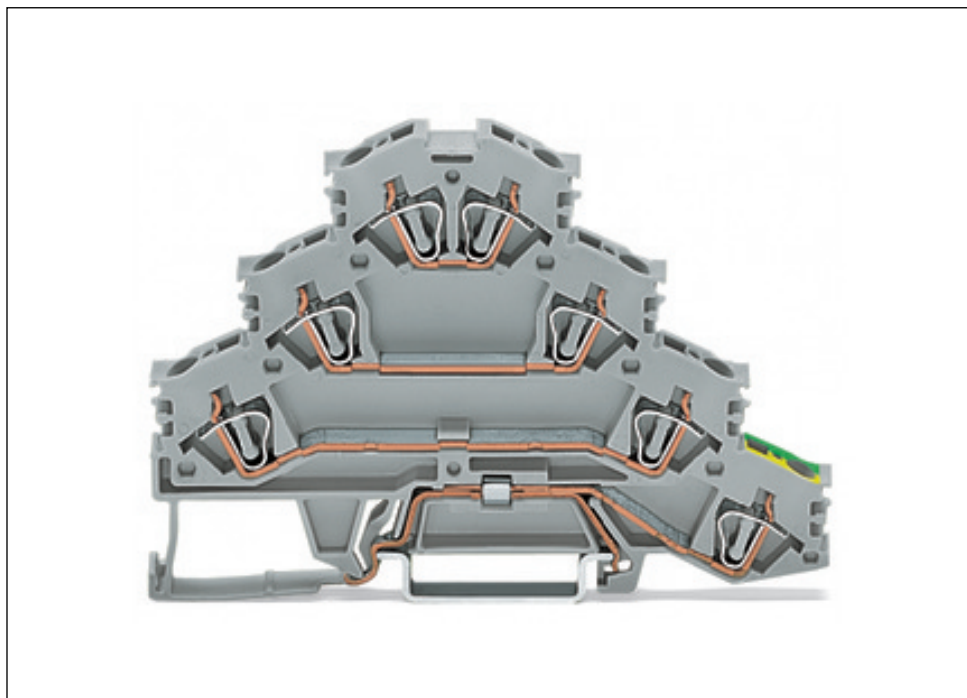

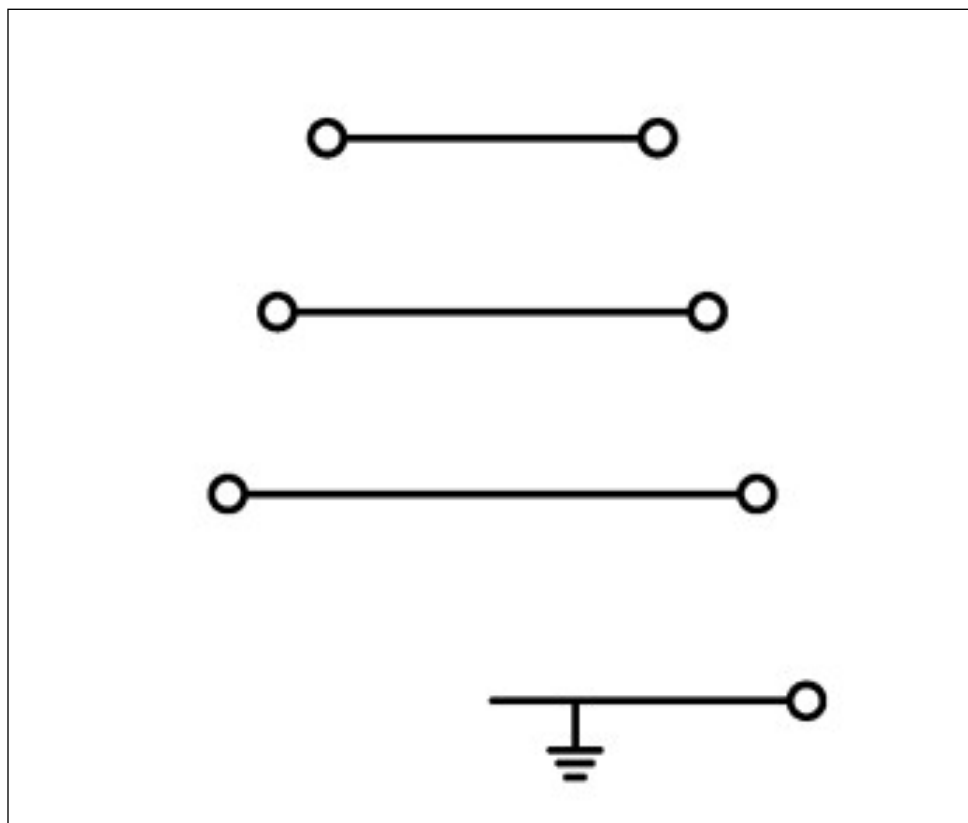
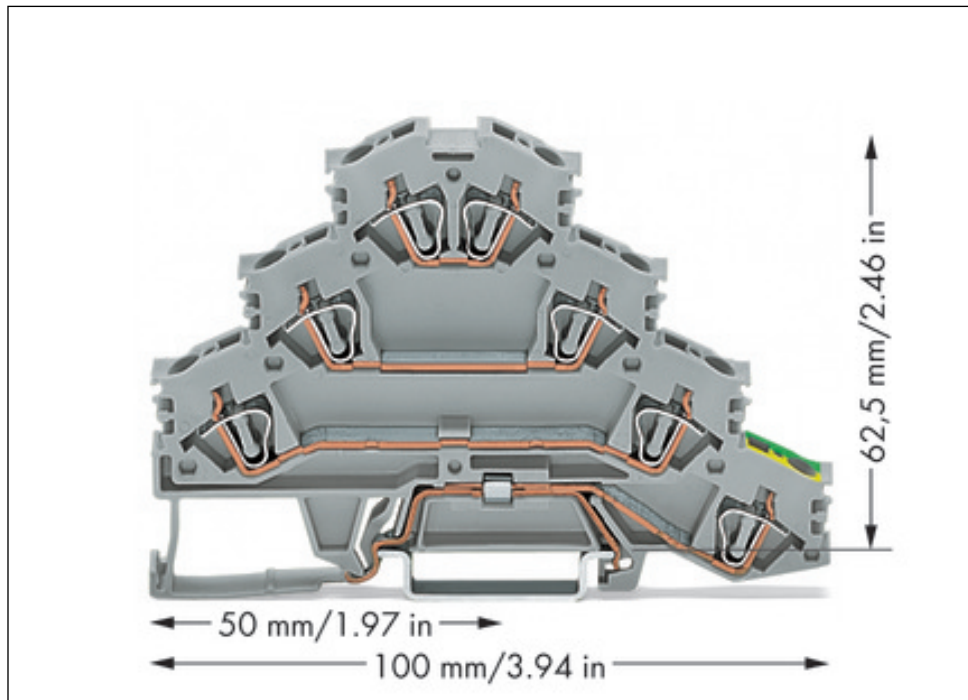

Address

WAGO Kontakttechnik GmbH & Co. KG

Hansastr. 27

32423 Minden

Telefon: 0571/887-0

Fax: 0571/887-169

<http://www.wago.com>

© WAGO Kontakttechnik GmbH & Co. KG

Technische Änderungen und Irrtümer vorbehalten.