

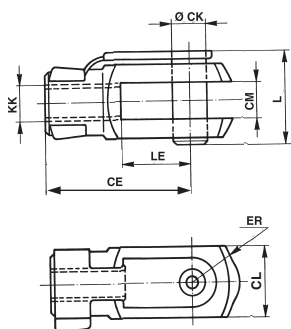

Female fork with clips in zinc-plated steel for piston rod according to ISO 8140 standard with pin



Cyl. Ø	CE	CK	CL	CM B12 B12	ER	KK	L	LE	Mass kg	Part number
32	40	10	20	10	16	M10 x 1,25	26	20	0,09	KF - 15032
40	48	12	24	12	19	M12 x 1,25	32	24	0,015	KF - 15040
50-63	64	16	32	16	25	M16 x 1,5	40	32	0,34	KF - 15050
80-100	80	20	40	20	32	M20 x 1,5	50	40	0,67	KF - 15080
125	110	30	55	30	45	M27 x 2	65	54	1,79	KF - 15125
160-200	144	35	70	35	57	M36 x 2	81	72	3,87	KF - 15160

Articulated self-lubricating fork in zinc plated steel

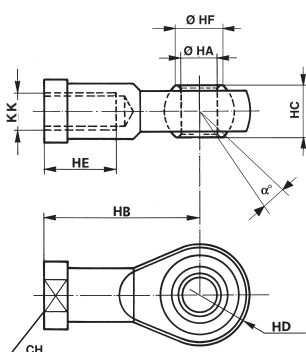

Cyl. Ø	a	CH	KK	HA	HB	HC	HD	HE	HF	Mass kg	Part number
32	13°	17	M10 x 1,25	10	43	14	14	20	12,9	0,076	KF - 17032
40	13°	19	M12 x 1,25	12	50	16	16	22	15,4	0,11	KF - 17040
50-63	15°	22	M16 x 1,5	16	64	21	21	28	19,3	0,22	KF - 17050
80-100	14°	30	M20 x 1,5	20	77	25	25	33	24,3	0,4	KF - 17080

Fork with axially mounted articulated pin

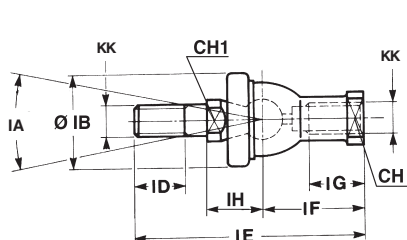

Cyl. Ø	CH	CH1	IA	KK	IH	IB	ID	IE	IF	IG	Mass kg	Part number
32	17	11	30°	M10 x 1,25	±0,3	32	15	74,5	35	18	0,12	KF - 22025
40	19	17	30°	M12 x 1,25	22	36	17	84	40	20	0,185	KF - 22040
50-63	22	19	22°	M16 x 1,5	27,5	47	23	112	50	27	0,36	KF - 22050
80-100	30	24	15°	M20 x 1,5	31,5	58	25	133	63	38	0,57	KF - 22080

Fork with angle-mounted articulated pin

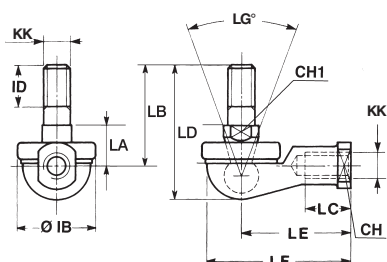

Cyl. Ø	CH	CH1	LG	KK	IB	ID	LA ±0,3	LB	LC	LD	LE	LF	Mass kg	Part number
32	17	11	50°	M10 x 1,25	32	15	17	37	21	50,5	43	57	0,11	KF - 23025
40	19	17	50°	M12 x 1,25	36	17	19	42	27	57,5	50	66	0,165	KF - 23040
50-63	22	19	40°	M16 x 1,5	47	23	23,5	60	33	79,5	64	84	0,33	KF - 23050
80-100	30	24	32°	M20 x 1,5	58	25	27	68	40	90	77	99	0,54	KF - 23080