

## Low Profile PCB Power Relay

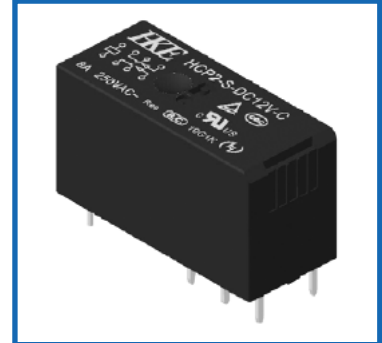

### DESCRIPTION

A range of Low Profile SPST/SPDT PCB Power Relays. These low profile, through hole mounting relays are designed for switching control signals within circuits.

### DISTINCTIVE FEATURES

- Low profile, height 15.8mm
- Dimensions: 29.0×12.6×15.8(mm)
- Switching capacity 16A
- Contact: 1 Form A, 1 Form B, 1 Form C
- Sensitivity: 400mW, 250mW
- Insulation: 5KV
- Creepage distance: 10mm
- Enclosure: S - Plastic Sealed Type
- Contact Material: Ag Alloy
- Electrical Life: 100,000 operations

### APPLICATIONS

These relays are suitable for a wide variety of applications, including automation control, automotive electronics, control and audio visual equipment.

16A

TUV

CQC

VDE

UL

SPDT

SPST



## ELECTRICAL SPECIFICATION

Contact Form		1 Form A, 1 Form C
Contact Rating		Resistive: 16A 250VAC/30VDC Inductive: 8A 250VAC Cosφ=0.4
Contact Resistance		Max. 100mΩ (6VDC 1A)
Insulation Resistance		Min. 1000MΩ 500VDC
Load	Max Switching Voltage	440VAC/120VDC
	Max Switching Current	16A
	Max Switching Power	4,000VA, 480W
	Min Switching Load	5VDC, 100mA
Dialectric Strength	Between Open Contacts	1,000VAC, 1min
	Between Coil & Contacts	5,000VAC, 1min
Nominal Coil Power		400mW



## ENVIRONMENTAL/OPERATING SPECIFICATION

Operating Temperature		-40°C to +85°C
Humidity		35~95%RH, +40°C
Shock Resistance	Endurance	1,000m/s <sup>2</sup>
	Misoperation	100m/s <sup>2</sup>
Vibration Resistance	Endurance	10~55Hz, 1.5mm double amplitude
	Misoperation	10~55Hz, 1.5mm double amplitude



## CERTIFICATION AND STANDARDS

File number	Contact Form	Power Consumption	Coil Voltage	Contact Rating	Remarks
TUV 50097843	A/C	0.4W	5-48VDC	16A 250VAC	Ambient Temperature: 85°C
CQC09002030014 (GB/T 21711.1-2008)	A/C	0.4W	5, 6, 9, 12, 24, 48, 60, 110 VDC	16A 250VAC	Ambient Temperature: 85°C
VDE 40043990	A/B/C	0.4W	5, 6, 9, 12, 18, 24, 36, 48 VDC	16A 250VAC	Ambient Temperature: 85°C
	C	0.4W	5, 6, 9, 12, 18, 24, 36, 48 VDC	NO/NC:16A/5A 250VAC	Ambient Temperature: 85°C



## CERTIFICATION AND STANDARDS

File number	Contact Form	Power Consumption	Coil Voltage	Contact Rating	Remarks
UL E164730	A/C	0.4W	5-110VDC	20A 250VAC(NO)	Insulation calss:F Ambient Temperature: 85°C
	A/B/C	0.4W/0.25W	5-110VDC	16A 250VAC	Insulation calss:F Ambient Temperature: 85°C
	B/C	0.4W/0.25W	5-110VDC	16A 250VAC(NC)	Insulation calss:F Ambient Temperature: 85°C
	A/C	0.4W	5-110VDC	TV-5 250VAC(NO)	Insulation calss:F Ambient Temperature: 40°C
	B/C	0.4W	5-110VDC	TV-5 250VAC(NC)	Insulation calss:F Ambient Temperature: 25°C



## TERMINALS

Terminal Type	Solder pins
Terminal Dimensions	See Drawings



## DIMENSIONS/DRAWINGS

Units	mm – unless stated otherwise
Height (excluding pins)	15.8
Width/diameter	12.6
Length/depth	29.0
Weight	Approximately 13.0g



**DIMENSIONS/DRAWINGS**

Dimensions 1 Form C

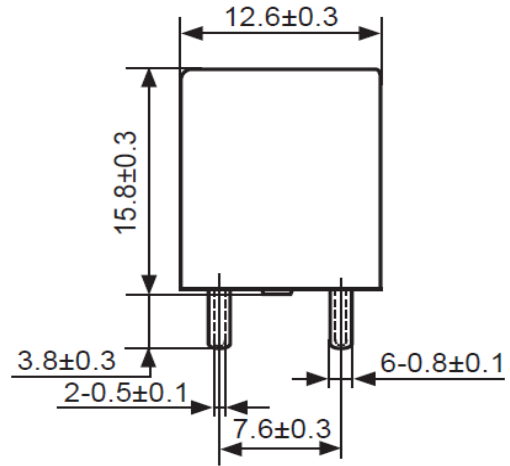
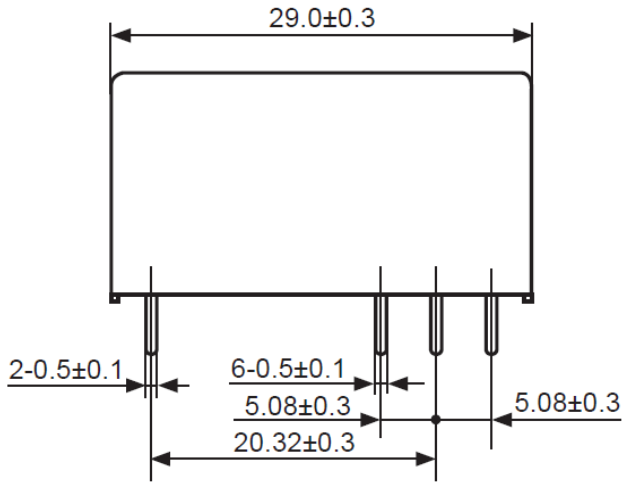

Wiring Diagram 1 Form C

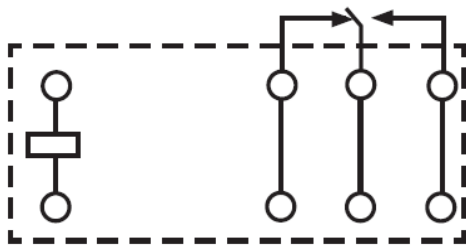

Mounting hole layout 1 Form C

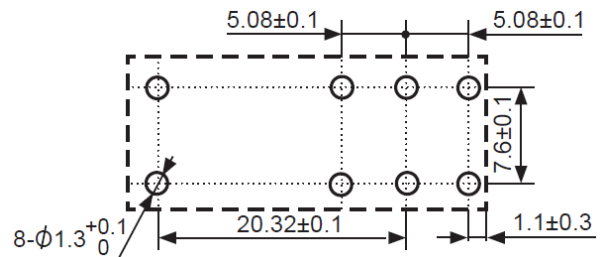

Dimensions 1 Form A

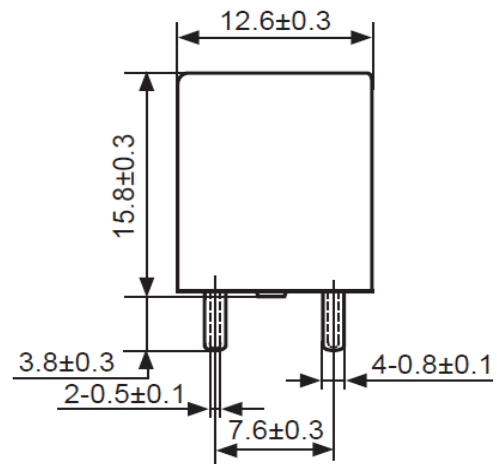
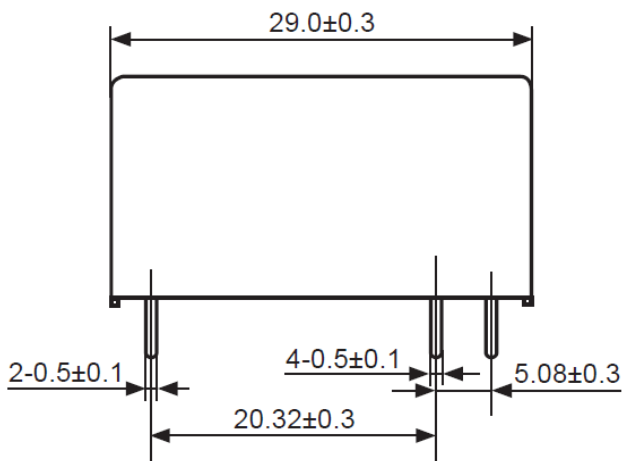



## DIMENSIONS/DRAWINGS

Wiring Diagram 1 Form A

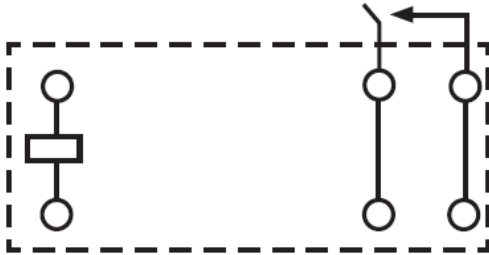

Mounting hole layout 1 Form A

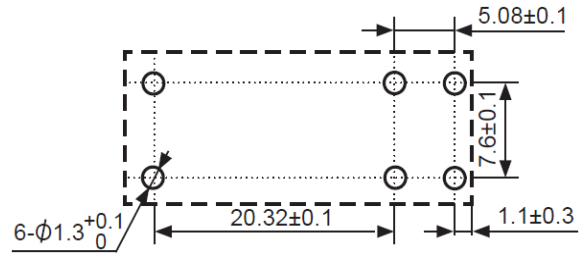

Maximum Switching Power

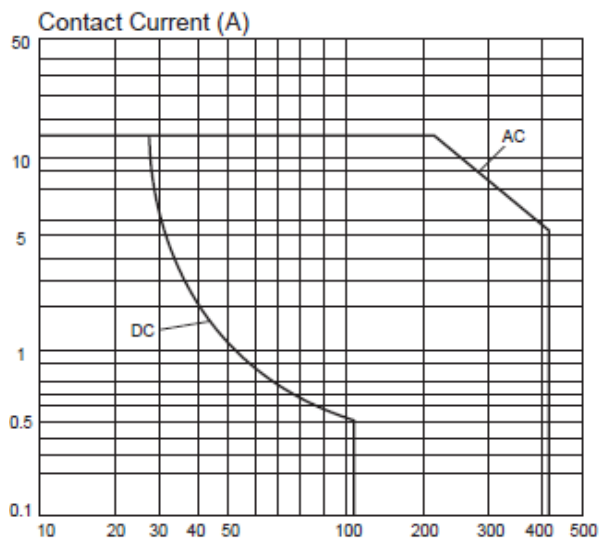

Max. Ambient Temp. Vs. Coil Voltage

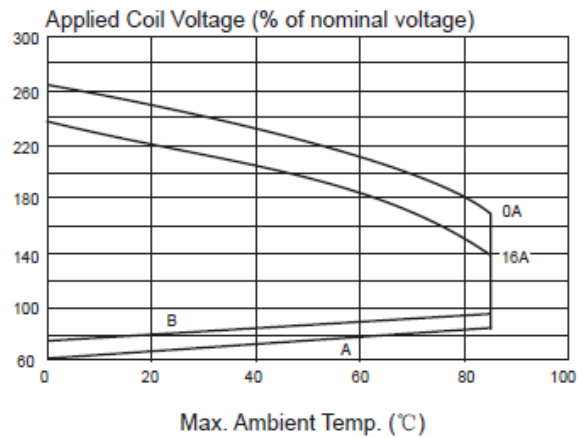

A: Coil temperature = Ambient temperature.  
B: 110% of nominal coil voltage at rated contact load.

Life Curves

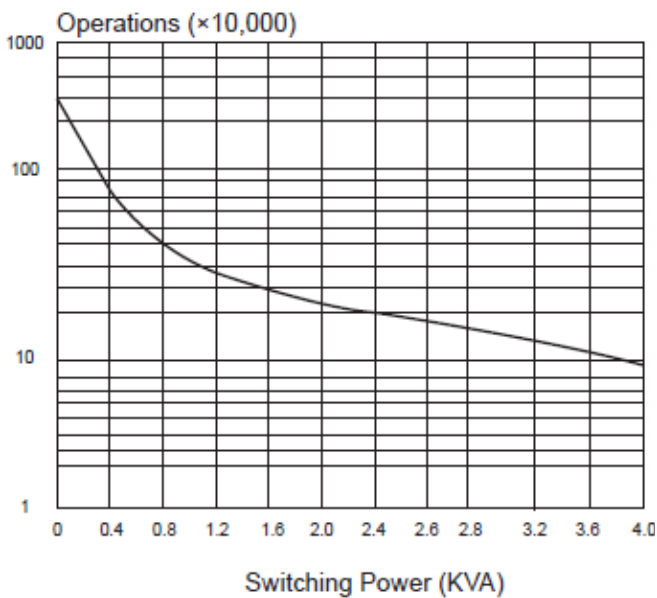



## PART NUMBER TABLE

Part number	Coil Power mW	Nominal Voltage VDC	Coil Resistance $\Omega$ +/-10%	Operating Voltage $\leq$ VDC	Release Voltage $\geq$ VDC	UNSPSC	EAN
<b>61-6411</b>	400	24	1440	16.8	2.4	39122325	5053556032914
<b>61-6412</b>	400	12	360	8.4	1.2	39122325	5053556032921
<b>61-6413</b>	400	24	1440	16.8	2.4	39122325	5053556032938



## OPTIONS (MOQ MAY APPLY)

Also available with a coil voltage of	12, 24 VDC
---------------------------------------	------------

For further information on pricing, delivery, and long-term stock agreements please get in touch with your local business development contact, telephone our main office on **01206 838000** or email **Sales@Rapidonline.com**.



Tried & trusted technology

Important Notice: This data sheet and its contents (the "Information") belong to Rapid Electronics Limited or are licensed to it. No licence is granted for the use of it other than for information purposes in connection with the products to which it relates. No licence of any intellectual property rights is granted. The Information is subject to change without notice and replaces all data sheets previously supplied. The Information supplied is believed to be accurate but Rapid Electronics Limited assumes no responsibility for its accuracy or completeness, any error in or omission from it or for any use made of it. Users of this data sheet should check for themselves the Information and the suitability of the products for their purpose and not make any assumptions based on information included or omitted. Liability for loss or damage resulting from any reliance on the Information or use of it (including liability resulting from negligence or where Rapid Electronics Limited were aware of the possibility of such loss or damage arising) is excluded. This will not operate to limit or restrict Rapid Electronics Limited's liability for death or personal injury resulting from its negligence.