

# DC Wallbox Stand

## Installation and Operation Manual

### INTRODUCTION

DC Wallbox Stand is designed for flexible and cost-effective installation of an DC Wallbox charger, best choice to power battery and plug-in electric vehicles, in indoor or outdoor environments.

### OUT OF THE BOX

The following items are included in the packaging. Only use the enclosed screws to install the stand or covers on the stand.

**Note: Do not mix stand and charger screws. Only use the enclosed stand screws in the installation. Do not use charger screws in the stand installation.**

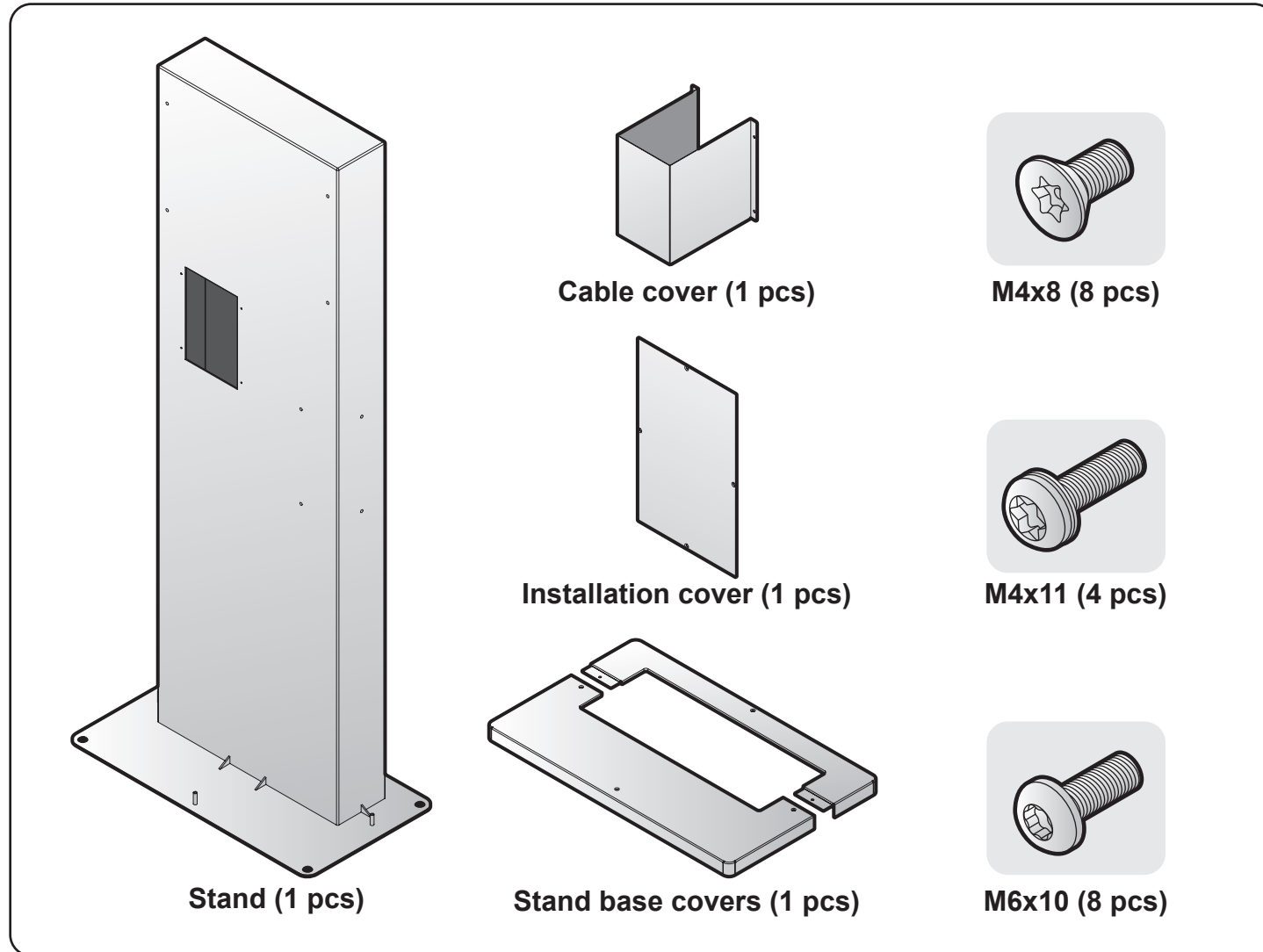

### IMPORTANT SAFETY AND WIRING INSTRUCTIONS

#### SAFETY AND COMPLIANCE

- This document provides instructions for the DC Wallbox Stand and should not be used for any other product. Before installation of this product, read this manual carefully and consult with a licensed contractor or trained installation expert to make sure of compliance with local building codes and safety standards.
- Only a licensed contractor, and/or a licensed electrician in accordance with all applicable state, local and national electrical codes and standards, should install the DC Wallbox Stand.
- Wear appropriate personal protective equipment.
- Ensure all materials and procedures used in the installation follow local building codes and safety standards.
- Information provided in this manual in no way exempts the user of responsibility to follow all applicable codes or safety standards.
- The manufacturer is not responsible for physical injury, damage to property or equipment caused by the installation of this device.

### BEFORE INSTALLING

#### SAFETY REQUIREMENTS

- Read all procedures and review local building and electrical codes before starting any installation.
- Ensure that upstream power is turned off during installation.
- Use appropriate protection when connecting to the main power distribution cable.
- Disconnecting switch for each ungrounded conductor of AC input shall be provided by others in accordance with the IEC61851-1.

#### RECOMMENDED TOOLS

The following tools are recommended for the DC Wallbox charger installation.

- (1x) Voltmeter or digital multi-meter
- (1x) Spirit level
- (1x) Hammer
- (1x) Concrete drilling machine
- (1x) Torx® Tamper-Resistant T20 screwdriver
- (1x) Torx® Tamper-Resistant T30 screwdriver
- (1x) Torx® Tamper-Resistant T15 screwdriver (security)
- (1x) No.19 wrench

#### PRODUCT FEATURES

- Dimension (W x H x D): 608 x 1420 x 328 mm (23.94" x 55.91" x 12.91")
- Weight: 36 kg (79.37 lbs)
- Requested cable: Refer to the Installation, Operation, and Maintenance manual (IOM) for this model.
- Optional cable: Ethernet cable (RJ45)

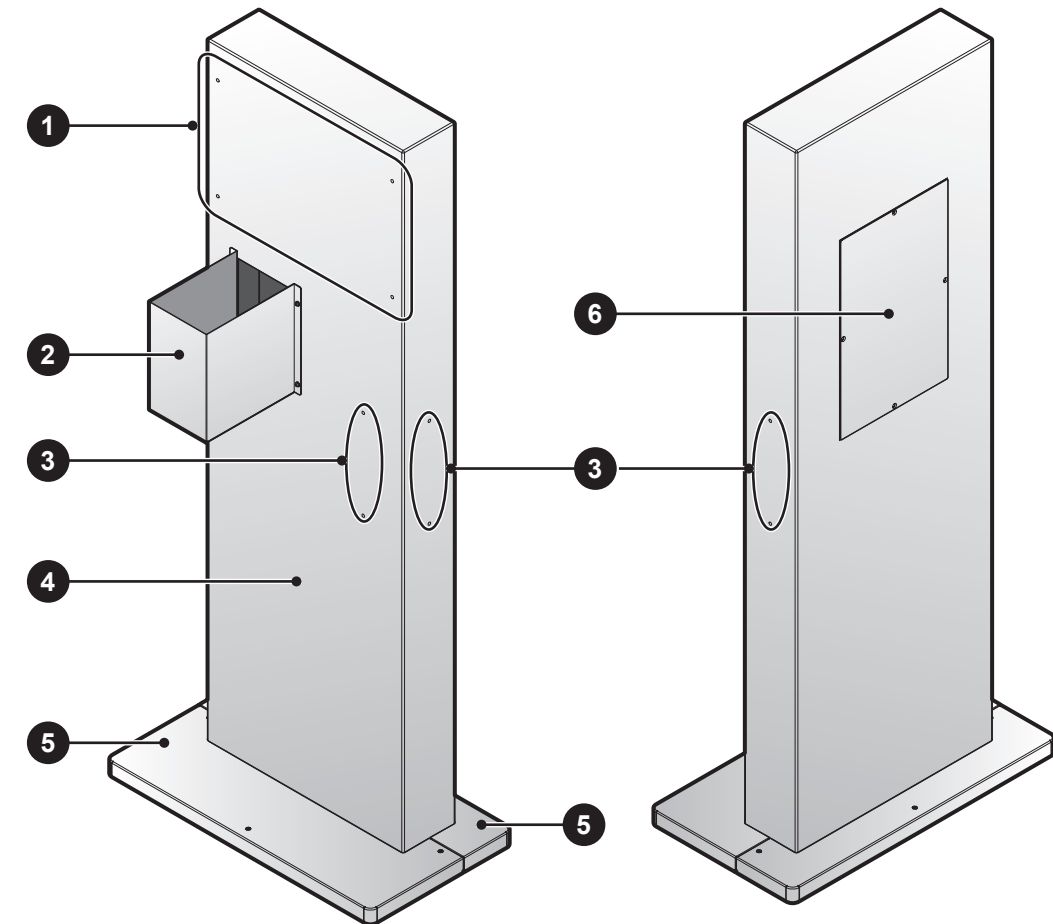

Position	Component	Fastener
1	Charger securing bracket position	4 x M6x10 Torx 30 screw
2	Cable cover	4 x M4x11
3	Charging plug hanger position	4 x M6x10 Torx 30 screw
4	Stand	4 x M12 Expansion Bolt (min. length 50 mm)
5	Stand base covers	4 x M4x8 (Torx security screws)
6	Installation cover	4 x M4x8 (Torx security screws)

**Note: Only those components listed in the accessory kit are included with the stand.**

# INSTALLING THE DC WALLBOX STAND

## 1. Prepare a flat concrete base.

The base must support a weight of 120 kg (264.55 lbs) and exceed the base frame (600 x 320 mm | 23.62" x 12.6"). The recommended size is: 700 x 420 mm (27.56" x 16.54").

A site assessment is required prior to any installation to evaluate conditions and requirements. Make sure this installation area is high enough to ensure that base of the stand is situated above a surface that may collect water. If needed, build a concrete foundation with a height of 200 mm (7.87"). Anchoring holes in the base must have a diameter of 15 mm (0.59") to accommodate four M12 expansion bolts.

**Note: Anchoring bolts are not included.**

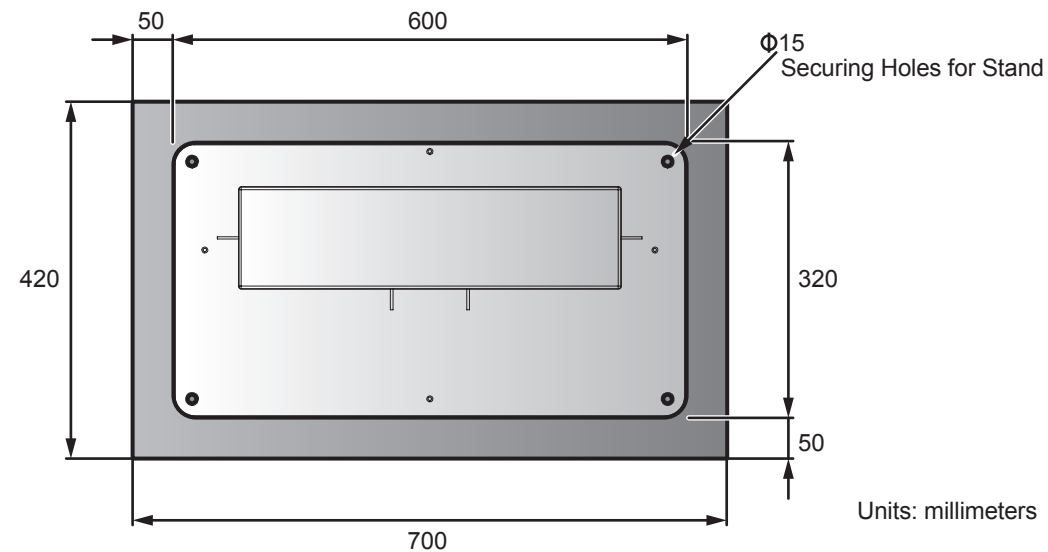

A cable length of 1.6 m (5.25') above the concrete base is recommended. Access to power controls is required.

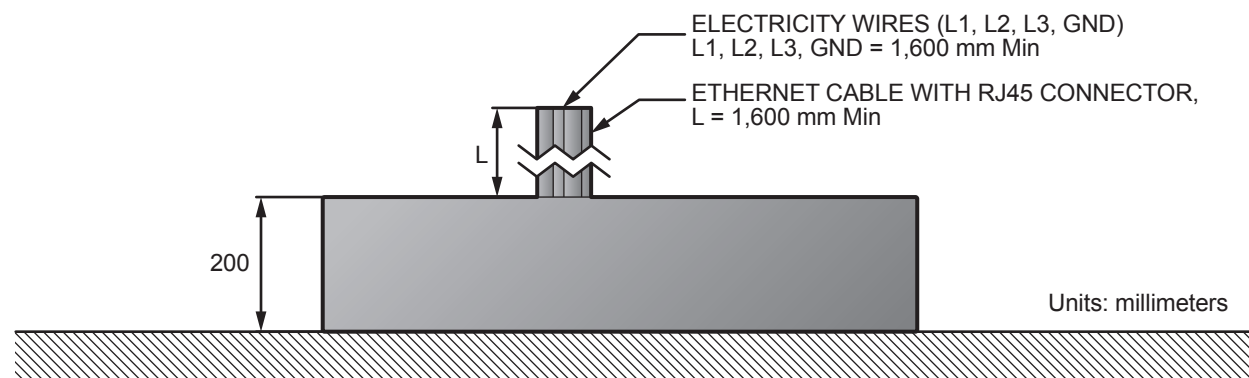

## 2. Dash marks indicate the drilling location for the anchoring holes (15 mm/0.59" diameter).

The marked area is the required cable conduit. The cables must be positioned in the marked area, see the following illustration, to effectively reach through the DC Wallbox charger.

**Note: The cable conduit may not be in the center of the concrete base.**

## 3. Place four M12 (min. 50 mm/1.9" length) anchoring bolts in the designated locations.



Bottom view

## 4. Route the cables from the base through the stand interior and out of the outlet.

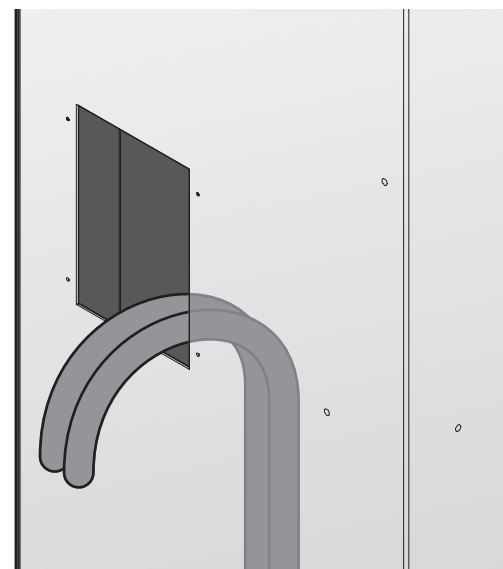

## 5. Align the stand with the anchoring bolts and lower it in the bolts. Take up any cable slack if needed.

## 6. Use a spirit level to ensure the stand is vertically and horizontally leveled.

## 7. Start on one corner, insert and tighten the nut. Alternate to the opposing corner and repeat for the remaining nuts.

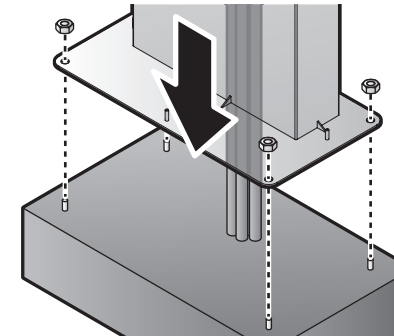

## 8. Install the stand base covers.

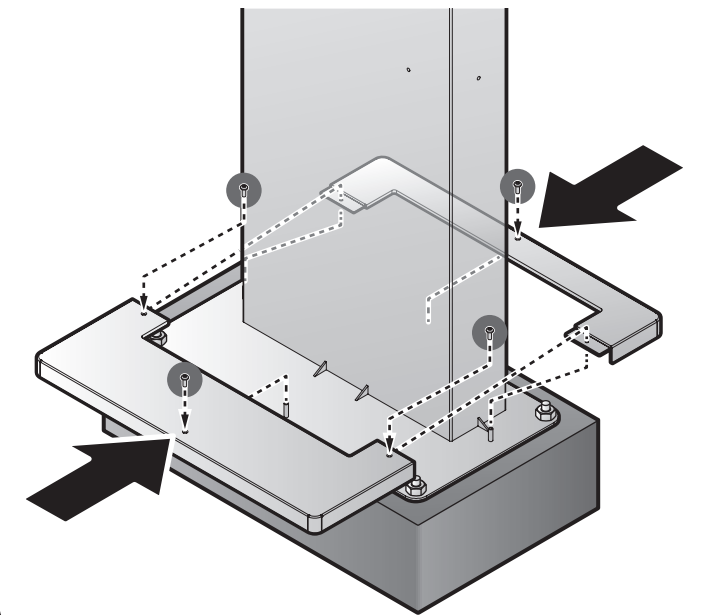

## 9. Install the installation cover.

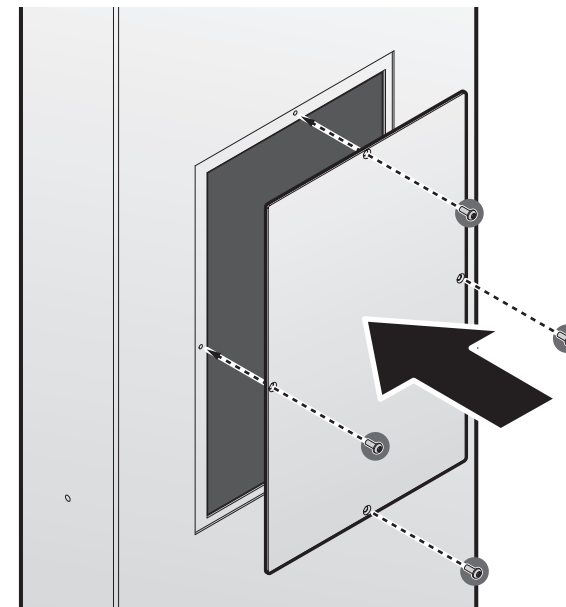

## 10. Install the cable cover.

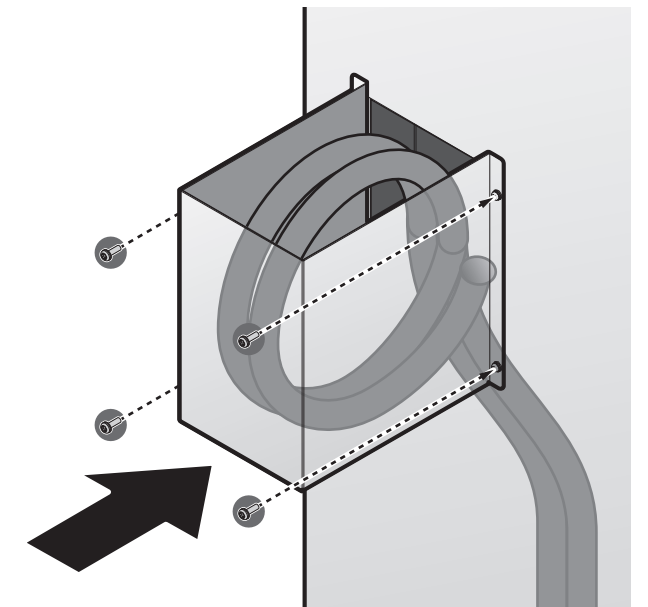

## 11. Install the DC Wallbox charger securing bracket (included with DC Wallbox charger).

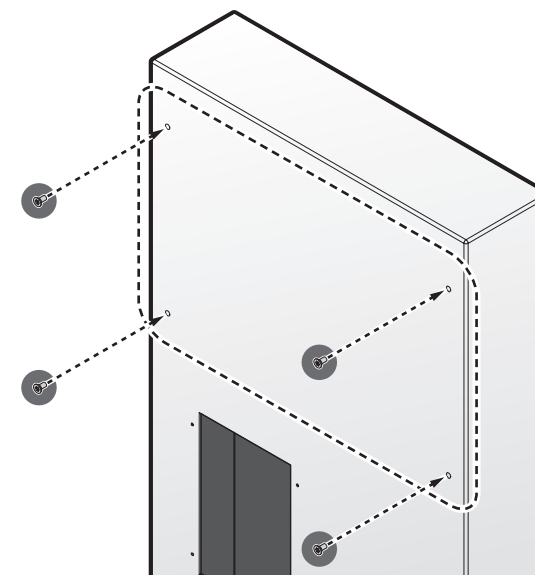

## 12. Select a position and install the charging plug hanger (included with DC Wallbox charger).

