



EurotestXD
MI 3155
Instruction manual
Version 1.8.9, Code no. 20 752 714

Distributor:

Manufacturer:

METREL d.d.
Ljubljanska cesta 77
1354 Horjul
Slovenia
web site: <http://www.metrel.si>
e-mail: metrel@metrel.si

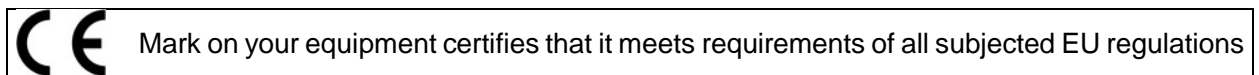

© 2020 METREL

The trade names Metrel[®], Smartec[®], Eurotest[®], Auto Sequence[®] are trademarks registered in Europe and other countries.

No part of this publication may be reproduced or utilized in any form or by any means without permission in writing from METREL.

i. About the instruction manual

- › This Instruction manual contains detailed information on the EurotestXD, its key features, functionalities and use.
- › It is intended for technically qualified personnel responsible for the product and its use.
- › Please note that LCD screenshots in this document may differ from the actual instrument screens in details due to firmware variations and modifications.
- › Metrel reserve the right to make technical modifications without notice as part of the further development of the product.

Table of Contents

1	General description	9
1.1	Warnings and notes	9
1.1.1	Safety warnings.....	9
1.1.2	Markings on the instrument	10
1.1.3	Warnings related to safety of batteries	10
1.1.4	Warnings related to safety of measurement functions	10
1.1.5	Notes related to measurement functions	11
1.2	Testing potential on PE terminal.....	14
1.3	Battery and charging of Li-ion battery pack	15
1.3.1	Precharge.....	16
1.3.2	Li – ion battery pack guidelines	18
1.4	Standards applied	19
2	Instrument set and accessories.....	21
2.1	Standard set MI 3155 EurotestXD	21
2.1.1	Optional accessories	21
3	Instrument description	22
3.1	Front panel.....	22
3.2	Connector panel.....	23
3.3	Back side	24
3.4	Carrying the instrument	26
3.4.1	Secure attachment of the strap.....	26
4	Instrument operation	28
4.1	General meaning of keys	28
4.2	General meaning of touch gestures.....	29
4.3	Virtual keyboard	30
4.4	Display and sound.....	31
4.4.1	Terminal voltage monitor.....	31
4.4.2	Battery indication.....	32
4.4.3	Bluetooth.....	32
4.4.4	Measurement actions and messages	32
4.4.5	Result indication.....	34
4.4.6	Auto Sequence® result indication.....	34
4.5	Instruments main menu	36
4.6	General Settings	37
4.6.1	Language	38
4.6.2	Power Save.....	38
4.6.3	Date and time.....	38
4.6.4	Workspace manager	39
4.6.5	Auto Sequence® groups	39
4.6.6	User accounts	39
4.6.7	Profiles	44
4.6.8	Settings	44
4.6.9	Devices	49
4.6.10	Initial Settings.....	49
4.6.11	About.....	50
4.7	Instrument profiles.....	51
4.8	Workspace Manager	52
4.8.1	Workspaces and Exports.....	52

4.8.2	Workspace Manager main menu.....	52
4.8.3	Operations with Workspaces.....	53
4.8.4	Operations with Exports.....	53
4.8.5	Adding a new Workspace.....	54
4.8.6	Opening a Workspace.....	54
4.8.7	Deleting a Workspace / Export.....	55
4.8.8	Importing a Workspace.....	55
4.8.9	Exporting a Workspace.....	56
4.9	Auto Sequence® groups.....	58
4.9.1	Auto Sequence® groups menu.....	58
5	Memory Organizer.....	60
5.1	Memory Organizer menu.....	60
5.1.1	Measurement statuses.....	60
5.1.2	Structure Objects.....	61
5.1.3	Selecting an active Workspace in Memory Organizer.....	63
5.1.4	Adding Nodes in Memory Organizer.....	64
5.1.5	Operations in Tree menu.....	65
5.1.6	Searching in Memory Organizer.....	82
6	Single tests.....	85
6.1	Selection modes.....	85
6.1.1	Single test (measurement) screens.....	87
6.1.2	Setting parameters, limits and comments of single tests.....	88
6.1.3	Single test start screen.....	89
6.1.4	Single test screen during test.....	90
6.1.5	Single test result screen.....	91
6.1.6	Editing graphs (Harmonics).....	92
6.1.7	Single test (inspection) screens.....	93
6.1.8	Help screens.....	96
6.1.9	Recall single test results screen.....	97
7	Tests and measurements.....	98
7.1	Voltage, frequency and phase sequence.....	98
7.2	R iso – Insulation resistance.....	101
7.2.1	Load pretest.....	103
7.3	R iso all – Insulation resistance.....	104
7.4	The DAR and PI diagnostic.....	106
7.5	Varistor test.....	108
7.6	R low – Resistance of earth connection and equipotential bonding.....	110
7.7	R low 4W.....	112
7.8	Continuity – Continuous resistance measurement with low current.....	113
7.8.1	Compensation of test leads resistance.....	115
7.9	Ring continuity (with EASI switch A 1214).....	116
7.10	Testing RCDs.....	118
7.10.1	RCD U_c – Contact voltage.....	119
7.10.2	RCD t – Trip-out time.....	121
7.10.3	RCD I – Trip-out current.....	121
7.10.4	RCD Auto – RCD Auto test.....	122
7.11	Z loop – Fault loop impedance and prospective fault current.....	126
7.12	Z loop 4W – Fault loop impedance and prospective fault current.....	128
7.13	Zs rcd – Fault loop impedance and prospective fault current in system with RCD ...	131
7.14	Z loop $m\Omega$ – High precision fault loop impedance and prospective fault current.....	133
7.15	Z line – Line impedance and prospective short-circuit current.....	136
7.16	Z line 4W – Line impedance and prospective short-circuit current.....	139

7.17	Z line mΩ – High precision line impedance and prospective short-circuit current	141
7.18	High Current (MI 3143 and MI 3144)	144
7.19	Voltage Drop	146
7.20	U touch – Touch voltage (MI 3143 and MI 3144).....	149
7.21	Z auto - Auto test sequence for fast line and loop testing	151
7.22	R line mΩ – DC resistance measurement (MI 3144)	153
7.23	ELR Current Injection Test (MI 3144)	155
7.24	ELR Combination Time Test (MI 3144)	157
7.25	EVSE Diagnostic Test (A 1632)	159
7.26	Earth – Earth resistance (3-wire test)	162
7.27	Earth 2 clamp – Contactless earthing resistance measurement (with two current clamps).....	163
7.28	Ro – Specific earth resistance.....	164
7.29	Power.....	166
7.30	Harmonics.....	167
7.31	Currents	169
7.32	Current Clamp Meter (MI 3144).....	170
7.33	ISFL – First fault leakage current.....	172
7.34	IMD – Testing of insulation monitoring devices.....	174
7.35	Rpe – PE conductor resistance	178
7.36	Illumination	179
7.37	Discharging time	181
7.38	AUTO TT – Auto test sequence for TT earthing system	182
7.39	AUTO TN (RCD) – Auto test sequence for TN earthing system with RCD.....	185
7.40	AUTO TN – Auto test sequence for TN earthing system without RCD.....	187
7.41	AUTO IT – Auto test sequence for IT earthing system.....	189
7.42	Locator.....	191
7.43	Visual and Functional inspections	192
7.44	Measurements using adapter MD 9273.....	193
7.44.1	Power CLAMP.....	194
7.44.2	Voltage CLAMP.....	195
7.44.3	Current CLAMP.....	197
7.44.4	Inrush CLAMP.....	198
7.44.5	Harmonics U CLAMP	200
7.44.6	Harmonics I CLAMP.....	201
8	Auto Sequences®	203
8.1	Selection of Auto Sequences®.....	203
8.1.1	Selecting an active Auto Sequence® group in Auto Sequences® menu.....	203
8.1.2	Searching in Auto Sequences® menu.....	204
8.1.3	Organization of Auto Sequences® in Auto Sequences® menu	205
8.2	Organization of an Auto Sequence®	206
8.2.1	Auto Sequence® view menu	206
8.2.2	Step by step execution of Auto Sequences®.....	208
8.2.3	Auto Sequence® result screen.....	210
8.2.4	Auto Sequence® memory screen.....	211
9	Communication.....	213
9.1	USB and RS232 communication	213
9.2	Bluetooth communication with Android devices.....	213
9.3	Communication with adapters	214
9.4	Bluetooth and RS-232 communication with scanners.....	215
10	Upgrading the instrument	216
11	Maintenance.....	217

11.1	Fuse replacement	217
11.2	Battery pack insertion / replacement	218
11.3	Cleaning.....	219
11.4	Periodic calibration.....	219
11.5	Service.....	219
12	Technical specifications.....	220
12.1	R iso, R iso all – Insulation resistance	220
12.2	Diagnostic test.....	221
12.3	R low, R low 4W – Resistance of earth connection and equipotential bonding	221
12.4	Continuity – Continuous resistance measurement with low current	222
12.5	Ring Continuity.....	222
12.6	RCD testing.....	223
12.6.1	General data.....	223
12.6.2	RCD U_c – Contact voltage.....	224
12.6.3	RCD t – Trip-out time.....	224
12.6.4	RCD I – Trip-out current	225
12.6.5	RCD Auto.....	225
12.7	Z loop, Z loop 4W – Fault loop impedance and prospective fault current.....	225
12.8	Zs rcd – Fault loop impedance and prospective fault current in system with RCD ...	227
12.9	Z loop m Ω – High precision fault loop impedance and prospective fault current	228
12.10	U touch – Touch voltage (MI 3143 and MI 3144).....	228
12.11	Z line, Z line 4W – Line impedance and prospective short-circuit current	228
12.12	Z line m Ω – High precision line impedance and prospective short-circuit current ...	229
12.13	Voltage Drop	229
12.14	High current (MI 3143 and MI 3144).....	229
12.15	Z auto, AUTO TT, AUTO TN, AUTO TN (RCD), AUTO IT	229
12.16	Rpe – PE conductor resistance	230
12.17	Earth – Earth resistance (3-wire measurement)	231
12.18	Earth 2 clamp – Contactless earthing resistance measurement (with two current clamps).....	231
12.19	Ro – Specific earth resistance.....	232
12.20	Voltage, frequency, and phase rotation	233
12.20.1	Phase rotation	233
12.20.2	Voltage / Online terminal voltage monitor	233
12.20.3	Frequency	233
12.21	Varistor test.....	233
12.22	Currents	234
12.23	Current clamp meter (MI 3144)	234
12.24	Power.....	235
12.25	Harmonics.....	235
12.26	ISFL – First fault leakage current.....	235
12.27	IMD	236
12.28	Illumination	236
12.29	Discharging time	237
12.30	Auto Sequences®	237
12.31	R line m Ω - DC resistance measurement (MI 3144)	237
12.32	ELR Current injection (MI 3144)	237
12.33	ELR Combination time test (MI 3144).....	237
12.34	EVSE Diagnostic test (A 1632).....	237
12.35	Power CLAMP (MD 9273).....	237
12.36	Voltage CLAMP (MD 9273).....	238
12.37	Current CLAMP (MD 9273)	238
12.38	Inrush CLAMP (MD 9273)	238
12.39	Harmonics U CLAMP (MD 9273).....	238

12.40	Harmonics I CLAMP (MD 9273)	238
12.41	General data	239
Appendix A	Commanders (A 1314, A 1401).....	240
A.1	 Warnings related to safety	240
A.2	Battery.....	240
A.3	Description of commanders.....	240
A.4	Operation of commanders	241
Appendix B	Locator receiver R10K.....	242
Appendix C	Structure objects	243
Appendix D	Default list of Auto Sequences®	246
Appendix E	Programming of Auto Sequences® on Metrel ES Manager.....	247
E.1	Auto Sequence® Editor workspace	247
E.2	Managing groups of Auto Sequences®	248
E.3	Auto Sequence® Name, Description and Image editing	251
E.4	Search within selected Auto Sequence® group.....	252
E.5	Elements of an Auto Sequence®	253
E.5.1	Auto Sequence® steps.....	253
E.5.2	Single tests.....	253
E.5.3	Flow commands	253
E.5.4	Number of measurement steps.....	253
E.6	Creating / modifying an Auto Sequence®.....	254
E.7	Description of flow commands.....	255
E.8	Custom Inspections programming	256
E.8.1	Creating and editing Custom Inspections	256
E.8.2	Applying Custom Inspections.....	259
Appendix F	Tests and Measurements with adapters	260

1 General description

1.1 Warnings and notes



1.1.1 Safety warnings

In order to reach high level of operator safety while carrying out various measurements using the EurotestXD instrument, as well as to keep the test equipment undamaged, it is necessary to consider the following general warnings:

- › **Read Instruction manual carefully, otherwise the use of the instrument may be dangerous for the operator, the instrument or for the equipment under test!**
- › **Consider warning markings on the instrument (see next chapter for more information).**
- › **If the test equipment is used in a manner not specified in this Instruction manual, the protection provided by the equipment could be impaired!**
- › **Do not use the instrument or any of the accessories if any damage is noticed!**
- › **Regularly check the instrument and accessories for correct functioning to avoid hazard that could occur from misleading results.**
- › **Consider all generally known precautions in order to avoid risk of electric shock while dealing with hazardous voltages!**
- › **Always check for the presence of dangerous voltage on PE test terminal of installation by touching the TEST key on the instrument or by any other method before starting single test and Auto Sequence® measurements. Make sure that the TEST key is grounded through human body resistance without any insulated material between (gloves, shoes, insulated floors, pens,...). PE test could otherwise be impaired and results of a single test or Auto Sequence® can mislead. Even detected dangerous voltage on PE test terminal cannot prevent running of a single test or Auto Sequence®. All such behaviour is regarded as misuse. Operator of the instrument must stop the activity immediately and eliminate the fault/connection problem before proceeding with any activity!**
- › **Use only standard or optional test accessories supplied by your distributor!**
- › **In case a fuse has blown follow the instructions in this manual in order to replace it! Use only fuses that are specified!**
- › **Service, calibration or adjustment of instruments and accessories is only allowed to be carried out by a competent authorized person!**
- › **Do not use the instrument in AC supply systems with voltages higher than 550 V.a.c.**
- › **Consider that protection category of some accessories is lower than of the instrument. Test tips and Tip commander have removable caps. If they are removed the protection falls to CAT II. Check markings on accessories!**
 - **cap off, 18 mm tip: CAT II up to 1000 V**
 - **cap on, 4 mm tip: CAT II 1000 V / CAT III 600 V / CAT IV 300 V**
- › **The instrument comes supplied with rechargeable Li-Ion battery pack. The battery pack should only be replaced with the same type as defined on the battery compartment label or as described in this manual!**

- › Hazardous voltages exist inside the instrument. Disconnect all test leads, remove the power supply cable and switch off the instrument before removing battery /fuse compartment cover.
- › Do not connect any voltage source on C1 inputs. It is intended only for connection of current clamps. Maximal input voltage is 3 V!

1.1.2 Markings on the instrument

- ›  Read the Instruction manual with special care to safety operation«. The symbol requires an action!



- › Do not use the instrument in AC supply systems with voltages higher than 550 Va.c.!

- ›  Mark on your equipment certifies that it meets requirements of all subjected EU regulations.



- ›  This equipment should be recycled as electronic waste.

1.1.3 Warnings related to safety of batteries

- › Use only batteries and power supply adapter delivered from the manufacturer or distributor of the test equipment.
- › Never dispose of the batteries in a fire as it may cause them to explode or generate a toxic gas.
- › Do not attempt to disassemble, crush or puncture the batteries in any way.
- › Do not short circuit or reverse polarity the external contacts on a battery.
- › Avoid exposing the battery to excessive shock/impacts or vibration.
- › Do not use a damaged battery.
- › The Li – ion battery contains safety and protection circuit, which if damaged, may cause the battery to generate heat, rupture or ignite.
- › Do not leave a battery on prolonged charge when not in use.
- › If a battery has leaking fluids, do not touch any fluids.
- › In case of eye contact with fluid, do not rub eyes. Immediately flush eyes thoroughly with water for at least 15 minutes, lifting upper and lower lids, until no evidence of the fluid remains. Seek medical attention.

1.1.4 Warnings related to safety of measurement functions

Insulation resistance (R iso, R iso – all)

- › Insulation resistance measurement should only be performed on de-energized objects!
- › Do not touch the test object during the measurement or before it is fully discharged! Risk of electric shock!

Continuity functions (R low, R low 4W, Continuity)

- › Continuity measurements should only be performed on de-energized objects!

1.1.5 Notes related to measurement functions

Insulation resistance (R iso, R iso – all)

- › The measuring range is decreased if using Tip commander A 1401.
- › If a voltage of higher than 30 V (AC or DC) is detected between test terminals, the measurement will not be performed.
- › Load pretest detects possible connection of appliances to the system during test. Test eliminates possible damage to the equipment that could be connected to the system during Insulation resistance measurements.
- › Load pretest is carried out between same terminals as the Insulation resistance measurement.
- › Load pretest is carried out only when $U_{iso} \leq 1000$ V.

Diagnostic test

- › If any insulation resistance values ($R_{ISO}(15\text{ s})$ or $R_{ISO}(60\text{ s})$) are over-ranged the **DAR** factor is not calculated. The result field is blank: DAR: _____!
- › If any insulation resistance values ($R_{ISO}(60\text{ s})$ or $R_{ISO}(10\text{ min})$) are over-ranged the **PI** factor is not calculated. The result field is blank: PI : _____!

Continuity functions (R low, R low 4W, Continuity)

- › If a voltage of higher than 10 V (AC or DC) is detected between test terminals, the measurement will not be performed.
- › Parallel loops may influence on test results.
- › In some kind of PRCDs types (PRCD-3p and PRCD-S+), the protective conductor is monitored. For protective conductor resistance measurement a test current of 200 mA is required. Direct application will cause tripping of PRCD, so PE conductor measurement is not possible.

In this case use a test parameter **Current** set to '**ramp**', where special ramp curve is used for PE conductor resistance measurement without tripping of PRCD. If **Current** parameter is set to '**normal**', a standard test current curve is used.

Earth, Earth 2 clamp, Ro

- › If voltage between test terminals is higher than 10 V (Earth, Earth 2 clamps) or 30 V (Ro) the measurement will not be performed.
- › Contactless earthing resistance measurement (using two current clamps) enables simple testing of individual earthing rods in large earthing system. It is especially suitable for use in urban areas because there is usually no possibility to place the test probes.
- › For two clamps earth resistance measurement clamps A 1018 and A 1019 should be used. Clamps A 1391 are not supported. The distance between clamps should be at least 30 cm.
- › For specific earth resistance measurements ρ Adaptor A 1199 should be used.

RCD t, RCD I, RCD Uc, RCD Auto

- › Parameters set in one function are also kept for other RCD functions!
- › Selective (time-delayed) RCDs have delayed response characteristics. As the contact voltage pre-test or other RCD tests influence the time delayed RCD it takes a certain period to recover into normal state. Therefore a time delay of 30 s is inserted before performing trip-out test by default.
- › Portable RCDs (PRCD, PRCD-2p, PRCD-3p, PRCD-S, PRCD-S+ and PRCD-K) are tested as general (non-delayed) RCDs. Trip-out times, trip-out currents and contact voltage limits are equal to limits of general (non-delayed) RCDs.
- › In some kind of PRCDs types (PRCD, PRCD-3p, PRCD-S+ and PRCD-K), the protective conductor is monitored and carried out in the opposite direction through current sensor circuitry. During periodic testing – when fault current flows through phase and protective conductor – this can cause misunderstanding, because PRCD reacts at

half the tripping fault current. In order to prevent this, use parameter **Sensitivity** set to **'Ipe monitoring'**, where test current will be a half of selected nominal tripping current.

- › If **Sensitivity** parameter is set to **'standard'**, a test current with nominal tripping current is used.
- › The a.c. part of MI and EV RCDs is tested as general (non-delayed) RCDs.
- › The d.c. part of MI and EV RCDs is tested with a d. c. test current The Pass limit is between 0.5 and 1.0 I_{dNDC} .
- › The Z_s rcd function takes longer to complete but offers much better accuracy of fault loop resistance (in comparison to the R_L sub-result in Contact voltage function).
- › Auto test is finished without x5 tests in case of testing the RCD types A, F, B and B+ with rated residual currents of $I_{dN} = 300$ mA, 500 mA, and 1000 mA or testing the RCD type AC with rated residual current of $I_{dN} = 1000$ mA . In this case Auto test result passes if all other results pass, and indications for x5 are omitted.
- › Auto test is finished without x1 tests in case of testing the RCD types B and B+ with rated residual currents of $I_{dN} = 1000$ mA. In this case Auto test result passes if all other results pass, and indications for x1 are omitted.
- › Tests for sensitivity $I_{dn}(+)$ and $I_{dn}(-)$ are omitted for selective type RCD.
- › Trip out time measurement for B and B+ type RCDs in AUTO function is made with sine-wave test current, while trip-out current measurement is made with DC test current.

Z loop, Zloop 4W, Zs rcd

- › The specified accuracy of tested parameters is valid only if the mains voltage is stable during the measurement.
- › The measurement accuracy and immunity against noise are higher if **I test** parameter in Zsrcd is set to 'Standard'.
- › Fault loop impedance (Z loop) measurements will trip an RCD.
- › The Z_s rcd measurement does not normally trip an RCD. However if a leakage current from L to PE already flows or if a very sensitive RCD is installed (for example EV type) the RCD could trip. In this case setting parameter **I test** to 'Low' can help.

Z line, Z line 4W, Voltage drop

- › In case of measurement of $Z_{Line-Line}$ with the instrument test leads PE and N connected together the instrument will display a warning of dangerous PE voltage. The measurement will be performed anyway.
- › Specified accuracy of tested parameters is valid only if mains voltage is stable during the measurement.
- › If the reference impedance is not set the value of Z_{REF} is considered as 0.00 Ω .
- › The lowest value of Z_{ref} , measured at different settings of the **Test** or **Phase** parameters is used for Voltage drop (ΔU) measurement in Voltage drop single test, Z_{auto} single test, auto tests and Auto Sequences®.
- › Measuring Z_{ref} without test voltage present (disconnected test leads) will reset Z_{ref} value to initial value.

Power, Harmonics, Currents

- › Consider polarity of current clamp (arrow on test clamp should be oriented toward connected load), otherwise result will be negative!

Illumination

- › LUXmeter type B (A 1172) and LUXmeter type C (A 1173) probes are supported by the instrument.
- › Artificial light sources reach full power of operation after a period of time (see technical data for light sources) and should be therefore switched on for this period of time before the measurements are taken.

- › For accurate measurement make sure that the milk glass bulb is lit without any shadows cast by hand, body or other unwanted objects.
- › Refer to the Illuminance handbook for more information.

Rpe

- › The specified accuracy of tested parameters is valid only if the mains voltage is stable during the measurement.
- › Measurement will trip an RCD if the parameter RCD is set to 'No'.
- › The measurement does not normally trip an RCD if the parameter RCD is set to 'Yes'. However, the RCD can trip if a leakage current from L to PE already flows.

IMD

- › It is recommended to disconnect all appliances from the tested supply to receive regular test results. Any connected appliance will influence the insulation resistance threshold test.

Z line mΩ, Z loop mΩ

- › MI 3143 Euro Z 440 V, MI 3144 Euro Z 800 V or A 1143 Euro Z 290 A adapter is required for these measurements.

AutoTT, Auto TN(RCD), Auto TN, Auto IT, Z auto

- › Voltage drop (ΔU) measurement in each Auto test is enabled only if Z_{REF} is set.
- › See notes related to Zline, Zloop, Zs rcd, Voltage drop, Rpe, IMD and ISFL single tests.

Auto Sequences®

- › Metrel Auto Sequences® are designed as guidance to tests in order to significantly reduce testing time, improve work scope and increase traceability of the tests performed. METREL assumes no responsibility for any Auto Sequence® by any means. It is the user's responsibility, to check adequacy for the purpose of use of the selected Auto Sequence®. This includes type and number of tests, sequence flow, test parameters and limits.
- › Auto Sequences® mode allows building custom-defined test sequences.
- › See notes related to single tests in the selected Auto Sequence®.
- › Compensate test leads resistance before entering Auto Sequences®.
- › Zref value for Voltage drop test (ΔU) implemented in any Auto Sequence® should be set in single test function.

1.2 Testing potential on PE terminal

In certain instance faults on the installation's PE wire or any other accessible metal bonding parts can become exposed to live voltage. This is a very dangerous situation since the parts connected to the earthing system are considered to be free of potential. In order to properly

check the installation against this fault the  key should be used as an indicator prior to performing live tests.

Examples for application of PE test terminal

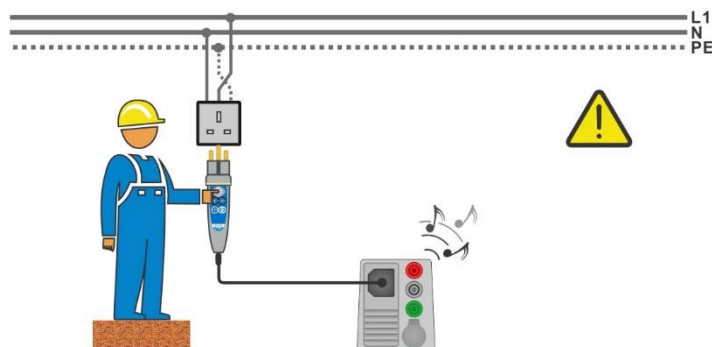

Figure 1.1: Reversed L and PE conductors (plug commander)

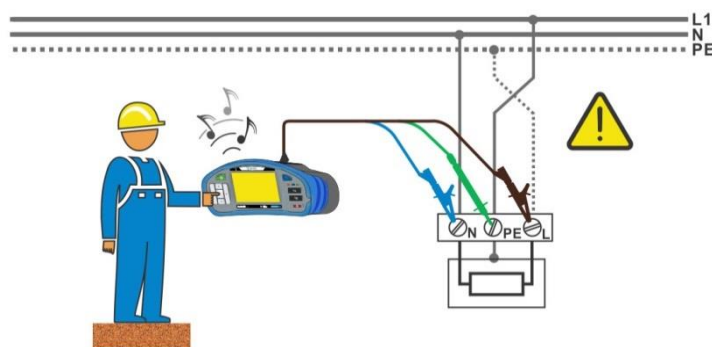

Figure 1.2: Reversed L and PE conductors (application of 3-wire test lead)

Warning!



Reversed phase and protection conductors! The most dangerous situation!

If dangerous voltage is detected on the tested PE terminal, stop all measurements immediately and ensure the cause of the fault is eliminated before proceeding with any activity!

Test procedure

- › Connect test cable to the instrument.
- › Connect test leads to the object under test, see **Figure 1.1** and **Figure 1.2**.
- › Touch  test probe for at least 1 second.
If PE terminal is connected to phase voltage the warning message is displayed, display is yellow coloured, instrument buzzer is activated and further measurements are disabled: RCD tests, Z loop, Zs rcd, Z auto, AUTO TT, AUTO TN, AUTO TN (rcd) and Auto Sequences®.

Notes:

- PE test terminal is active in the Voltage, Rpe, RCD tests, Z loop, Zs rcd, Z auto, Z line, ΔU, AUTO TT, AUTO TN, AUTO TN (rcd), AUTO IT measurements and Auto Sequences® only!
- In case of detection of phase voltage on PE terminal in IT earthing system, the tests can be enabled/disabled according to setting of parameter 'Ignore PE probe warning (IT)'.
- For correct testing of PE terminal, the  key has to be touched for at least 1 second.
- Make sure that the TEST key is grounded through human body resistance without any insulated material between (gloves, shoes, insulated floors, pens, ...). PE test could otherwise be impaired and results of a single test or Auto Sequence® can mislead. Even detected dangerous voltage on PE test terminal cannot prevent running of a single test or Auto Sequence®. All such behaviour is regarded as misuse. Operator of the instrument must stop the activity immediately and eliminate the fault/connection problem before proceeding with any activity!

1.3 Battery and charging of Li-ion battery pack

The instrument is designed to be powered by rechargeable Li-ion battery pack. The LCD contains an indication of battery condition (upper right section of LCD). In case the battery is too weak the instrument indicates this as shown in **Figure 1.3**.

Symbol:

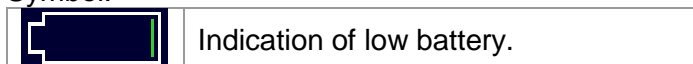

Figure 1.3: Battery test

The battery is charged whenever the power supply is connected to the instrument. The charger socket polarity is shown in **Figure 1.4**. Internal circuit controls (CC, CV) charging and assures maximum battery lifetime. Nominal operating time is declared for battery with nominal capacity of 4.4 Ah.



Figure 1.4: Charger socket polarity

The instrument automatically recognizes the connected power supply and begins charging.

Symbol:

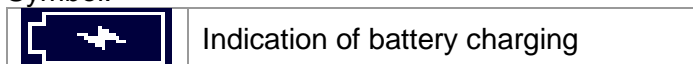

Figure 1.5: Charging indication (animation)

Battery and charging characteristic

Typical

Battery types	18650T22A2S2P 18650T22A2S4P (optional)
Charging mode	CC / CV
Nominal voltage	7,2 V
Rated capacity	4400 mAh (type: 18650T22A2S2P) 8800 mAh (type: 18650T22A2S4P)
Max charging voltage	8,0 V
Max charging current	2,2 A (type: 18650T22A2S2P) 3,0 A (type: 18650T22A2S4P)
Max discharge current	2,5 A
Typical charging time	3 hours (type: 18650T22A2S2P) 4,5 hours (type: 18650T22A2S4P)

Typical charging profile which is also used in this instrument is shown in **Figure 1.6**.

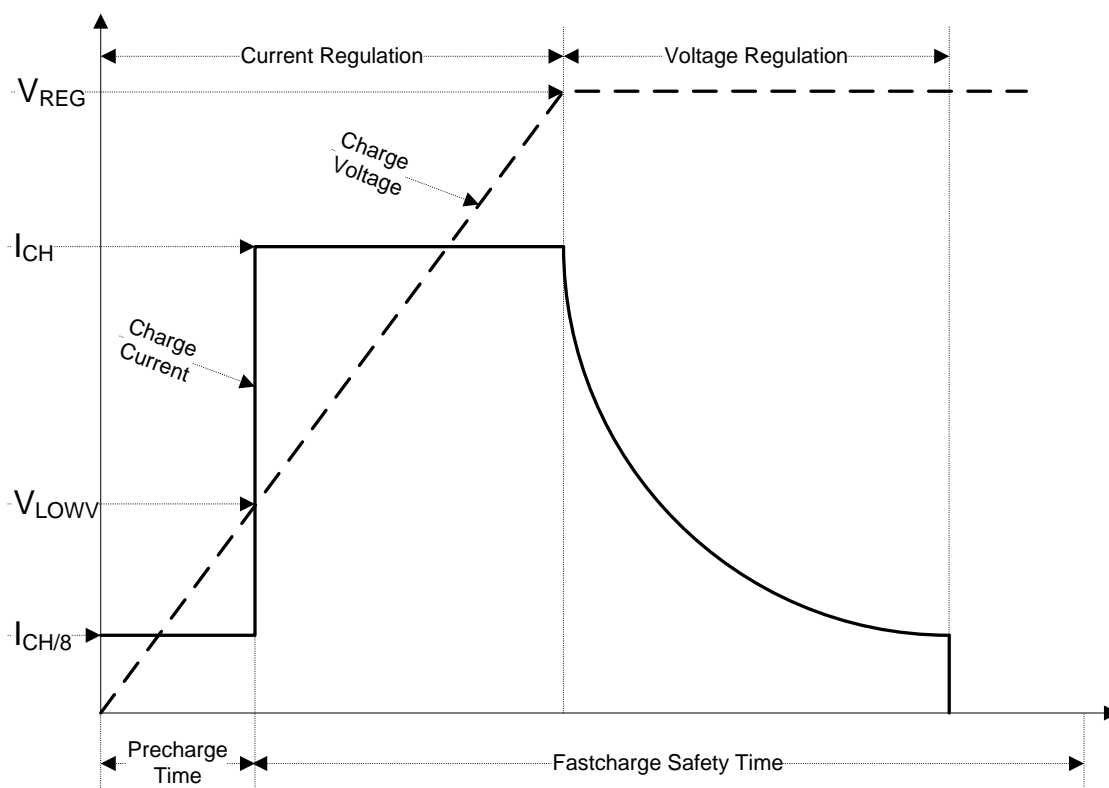

Figure 1.6: Typical charging profile

where:

- V_{REG} Battery charging voltage
- V_{LOWV} Precharge threshold voltage
- I_{CH} Battery charging current
- $I_{CH/8}$ 1/8 of the charging current

1.3.1 Precharge

On power up, if the battery voltage is below the V_{LOWV} threshold, the charger applies 1/8 of the charging current to the battery. The precharge feature is intended to revive deeply discharged

battery. If the V_{LOWV} threshold is not reached within 30 minutes of initiating precharge, the charger turns off and a FAULT is indicated.



Figure 1.7: Battery fault indication (charging suspended, timer fault, battery absent)



Figure 1.8: Battery full indication (charging completed)

Note:

- As a safety backup, the charger also provides an internal 5-hour charge timer for fast charge.

Typical charging time is 3 hours (Battery type: 18650T22A2S2P) in the temperature range of 5°C to 60°C.

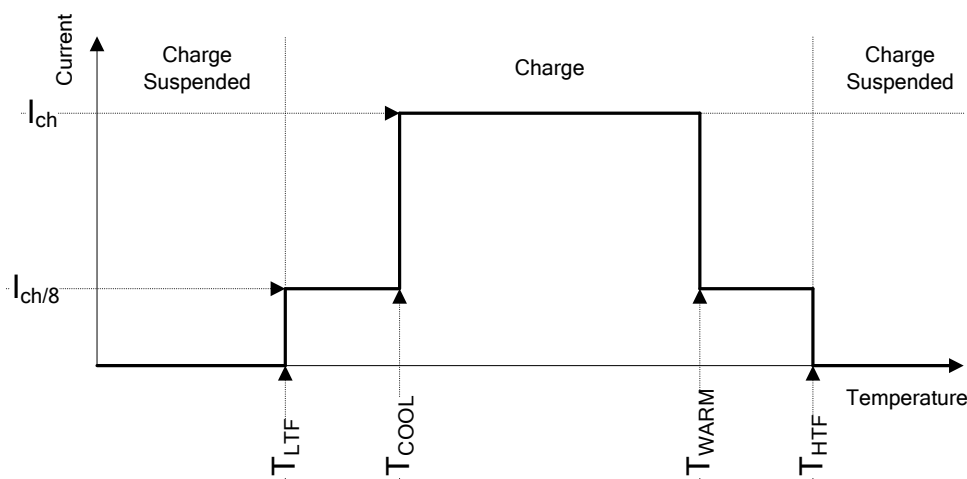

Figure 1.9: Typical charging current vs temperature profile

where:

- T_{LTF} Cold temperature threshold (typ. -15°C)
- T_{COOL} Cool temperature threshold (typ. 0°C)
- T_{WARM} Warm temperature threshold (typ. +60°C)
- T_{HTF} Hot temperature threshold (typ. +75°C)

The charger continuously monitors battery temperature. To initiate a charge cycle, the battery temperature must be within the T_{LTF} to T_{HTF} thresholds. If battery temperature is outside of this range, the controller suspends charge and waits until the battery temperature is within the T_{LTF} to T_{HTF} range.

If the battery temperature is between the T_{LTF} and T_{COOL} thresholds or between the T_{WARM} and T_{HTW} thresholds, charge is automatically reduced to $I_{CH/8}$ (1/8 of the charging current).

1.3.2 Li – ion battery pack guidelines

Li – ion rechargeable battery pack requires routine maintenance and care in their use and handling. Read and follow the guidelines in this Instruction manual to safely use Li – ion battery pack and achieve the maximum battery life cycles.

Do not leave batteries unused for extended periods of time – more than 6 months (self – discharge).

When a battery has been unused for 6 months, check the charge status, see chapter **4.4.2 Battery indication**. Rechargeable Li – ion battery pack has a limited life and will gradually lose capacity to hold a charge. As the battery loses capacity, the length of time it will power the product decreases.

Storage:

- › Charge or discharge the instruments battery pack to approximately 50% of capacity before storage.
- › Charge the instrument battery pack to approximately 50% of capacity at least once every 6 months.

Transportation:

- › Always check all applicable local, national, and international regulations before transporting a Li – ion battery pack.



Handling Warnings:

- › **Do not disassemble, crush, or puncture a battery in any way.**
- › **Do not short circuit or reverse polarity the external contacts on a battery.**
- › **Do not dispose of a battery in fire or water.**
- › **Avoid exposing the battery to excessive shock/impacts or vibration.**
- › **Do not use a damaged battery.**
- › **The Li – ion battery contains safety and protection circuit, which if damaged, may cause the battery to generate heat, rupture or ignite.**
- › **Do not leave a battery on prolonged charge when not in use.**
- › **If a battery has leaking fluids, do not touch any fluids.**
- › **In case of eye contact with fluid, do not rub eyes. Immediately flush eyes thoroughly with water for at least 15 minutes, lifting upper and lower lids, until no evidence of the fluid remains. Seek medical attention.**

1.4 Standards applied

The EurotestXD instruments are manufactured and tested in accordance with the following regulations:

Electromagnetic compatibility (EMC)

BS EN 61326-1 Electrical equipment for measurement, control and laboratory use – EMC requirements
Class B (Hand-held equipment used in controlled EM environments)

Safety (LVD)

BS EN 61010-1 Safety requirements for electrical equipment for measurement, control and laboratory use – Part 1: General requirements

BS EN 61010-2-030 Safety requirements for electrical equipment for measurement, control and laboratory use – Part 2-030: Particular requirements for testing and measuring circuits

BS EN 61010-031 Safety requirements for electrical equipment for measurement, control and laboratory use – Part 031: Safety requirements for hand-held probe assemblies for electrical measurement and test

BS EN 61010-2-032 Safety requirements for electrical equipment for measurement, control, and laboratory use - Part 2-032: Particular requirements for hand-held and hand-manipulated current sensors for electrical test and measurement

Functionality

BS EN 61557 Electrical safety in low voltage distribution systems up to 1000 V_{AC} and 1500 V_{AC} – Equipment for testing, measuring or monitoring of protective measures
Part 1: General requirements
Part 2: Insulation resistance
Part 3: Loop resistance
Part 4: Resistance of earth connection and equipotential bonding
Part 5: Resistance to earth
Part 6: Residual current devices (RCDs) in TT and TN systems
Part 7: Phase sequence
Part 10: Combined measuring equipment
Part 12: Performance measuring and monitoring devices (PMD)
Part 14: Equipment for testing the safety of electrical equipment for machinery

DIN 5032 Photometry
Part 7: Classification of illuminance meters and luminance meters

Reference standards for electrical installations and components

BS EN 61008 Residual current operated circuit-breakers without integral overcurrent protection for household and similar uses

BS EN 61009 Residual current operated circuit-breakers with integral overcurrent protection for household and similar uses

BS IEC 60364-4-41 Electrical installations of buildings Part 4-41 Protection for safety – protection against electric shock

BS 7671 IEE Wiring Regulations (18th edition)

AS/NZS 3017 Electrical installations – Verification guidelines

BS EN IEC 62752 In-cable control and protection device for mode 2 charging of electric road vehicles (IC-CPD)

BS IEC 62955 Residual direct current detecting device (RDC-DD) to be used for mode 3 charging of electric vehicles

Li – ion battery pack

BS EN 62133-2 Secondary cells and batteries containing alkaline or other non-acid electrolytes – Safety requirements for portable sealed secondary lithium cell, and for batteries made from them, for use in portable applications – Part 2: Lithium systems protection for household and similar uses

2 Instrument set and accessories

2.1 Standard set MI 3155 EurotestXD

- › Instrument MI 3155 EurotestXD
- › Soft carrying bag
- › Set of carrying straps
- › Earth set, 3-wire, 20 m
- › Plug commander, 1.5 m + 2 batteries, size AAA
- › 3-wire test lead, 3 x 1.5 m
- › 4-wire test lead, 4 x 1.5 m
- › 2.5 kV test lead, 2 x 1.5 m
- › Test probe, 4 pcs (black, blue, green, red)
- › Crocodile clip, 6 pcs (black x 2, blue, green, red x 2)
- › Current clamp 1000:1
- › Current clamp (low range, leakage)
- › RS232-PS/2 cable
- › USB cable
- › Li-ion battery pack, 7.2 V , 4400 mAh (Type: 18650T22A2S2P)
- › Power supply adapter 12 V, 3 A (Type: CGSW-1203000)
- › CD includes:
 - PC software Metrel ES Manager
 - Instruction manual
 - "Guide for testing and verification of low voltage installations" handbook
- › Quick guide
- › Calibration Certificate

2.1.1 Optional accessories

See the attached sheet for a list of optional accessories that are available on request from your distributor.

3 Instrument description

3.1 Front panel



Figure 3.1: Front panel

1	4,3" COLOR TFT DISPLAY WITH TOUCH SCREEN
2	SAVE key Stores actual measurement result(s)
3	CURSOR keys Navigate in menus
4	RUN key Start / stop selected measurement. Enter selected menu or option. View available values for selected parameter / limit.
5	ON / OFF key Switch instrument on / off. The instrument automatically switches off after 10 minutes of idle state (no key pressed or any touchscreen activity) Press and hold the key for 5 s to switch off the instrument.
6	GENERAL SETTINGS key Enter General settings menu.
7	OPTIONS key Show detailed view of options.
8	MEMORY ORGANIZER shortcut key Shortcut key to enter Memory organizer menu.
9	SINGLE TESTS shortcut key Shortcut key to enter Single Tests menu.
10	AUTO SEQUENCES® shortcut key Shortcut key to enter Auto Sequences® menu.
11	ESC key Back to previous menu.

3.2 Connector panel

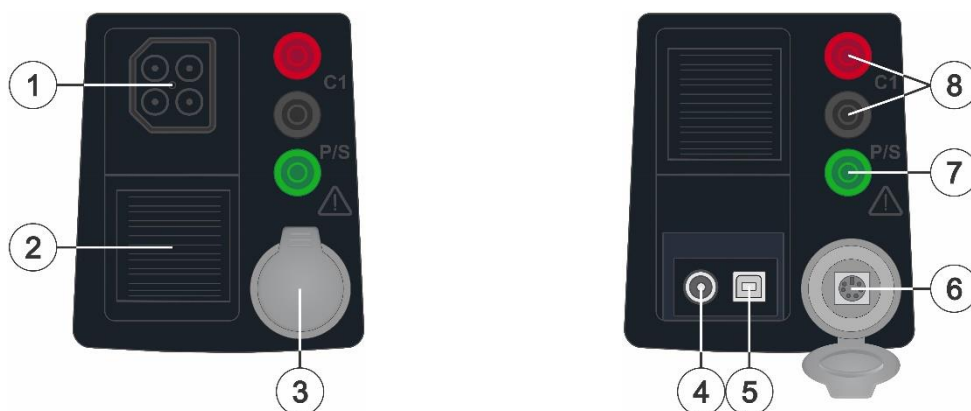



Figure 3.2: Connector panel

	Test connector
	L/L1 pin – In 4-wire measurements used as a current probe C1.
1	N/L2 pin – In 4-wire measurements used as a current probe C2.
	PE/L3 pin – In 4-wire measurements used as a voltage probe P2.
	S pin – In 4-wire measurements used as a voltage probe P1.
2	Protection cover
3	Protection cover – PS/2 communication port
4	Charger socket 
5	USB communication port Communication with PC USB (2.0) port
6	PS/2 communication port Communication with PC RS232 serial port Connection to optional measuring adapters Connection to barcode / RFID reader
7	P/S input External probe input for contact voltage measurement
8	C1 inputs Current clamp measuring input



Warnings!

- › Maximum allowed voltage between any test terminal and ground is 550 V!
- › Maximum allowed voltage between test terminals on test connector is 550 V!
- › Maximum allowed voltage on test terminal C1 is 3 V!
- › Maximum short-term voltage of external power supply adapter is 14 V!

3.3 Back side



Figure 3.3: Back view

1	Battery / fuse compartment cover
2	Fixing screws for battery / fuse compartment cover
3	Back panel information label

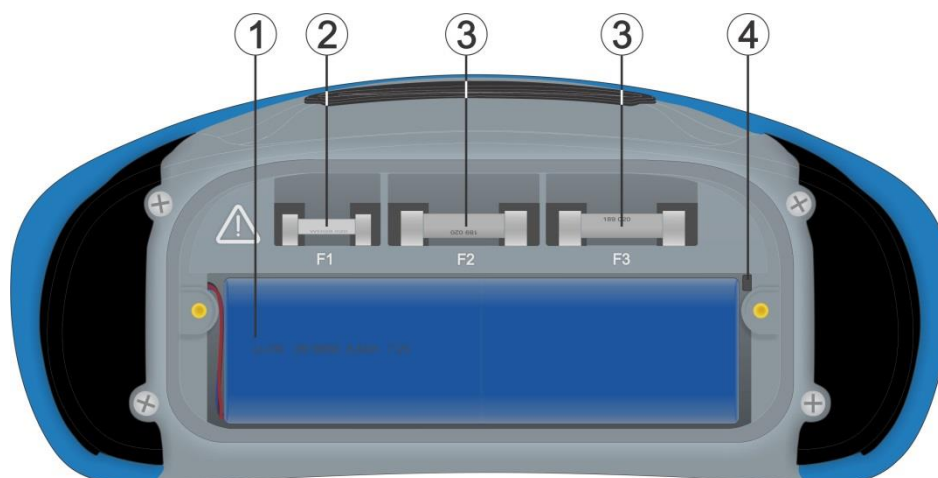

Figure 3.4: Battery and fuse compartment

1	Li-ion battery pack	Type: 18650T22A2S2P Type: 18650T22A2S4P (optional)
2	Fuse F1	M 315 mA / 250 V
3	Fuses F2 and F3	F 5 A / 500 V (breaking capacity 50 kA)

4 SD card slot

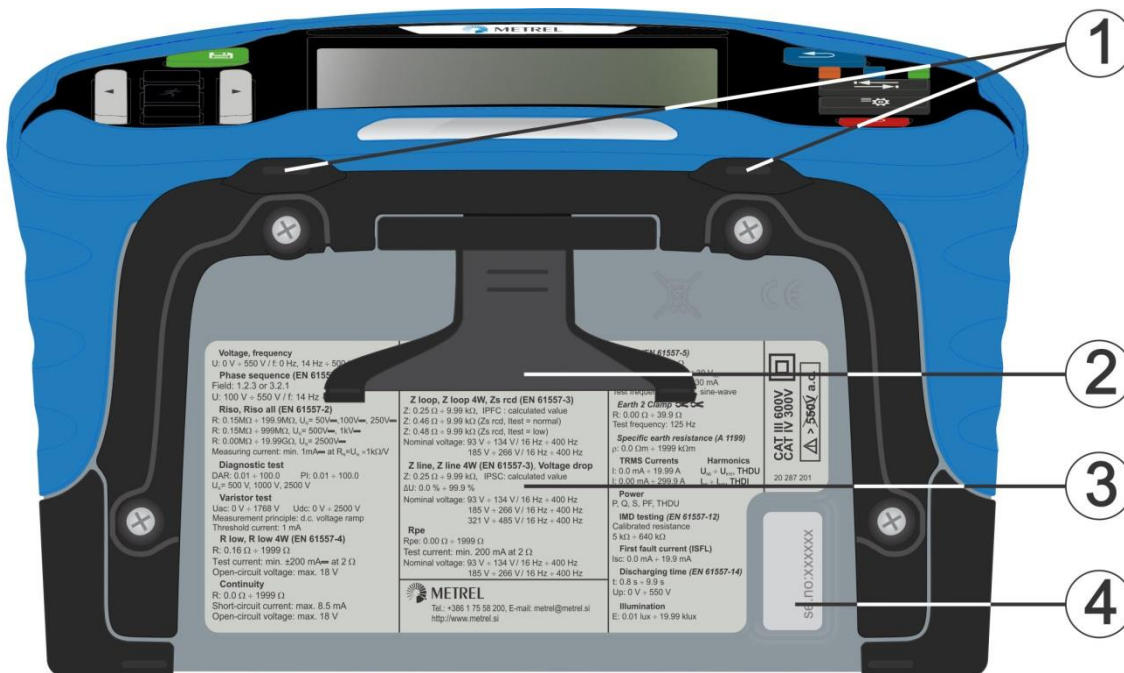
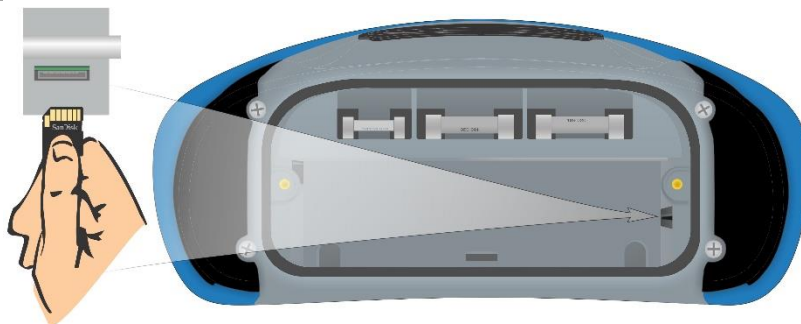

Figure 3.5: Bottom view

- 1 Neck belt openings
- 2 Stand for desktop use
- 3 Bottom information label
- 4 Serial number label

3.4 Carrying the instrument

With the neck-carrying belt supplied in standard set, various possibilities of carrying the instrument are available. Operator can choose appropriate one on basis of his operation, see the following examples:



The instrument hangs around operator's neck only – quick placing and displacing.



The instrument can be used even when placed in soft carrying bag – test cable connected to the instrument through the front aperture.

3.4.1 Secure attachment of the strap

You can choose between two methods:

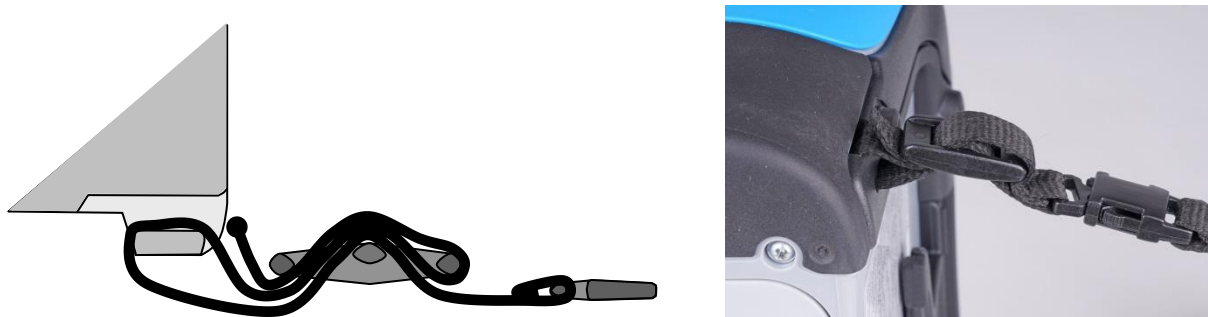

Figure 3.6: First method

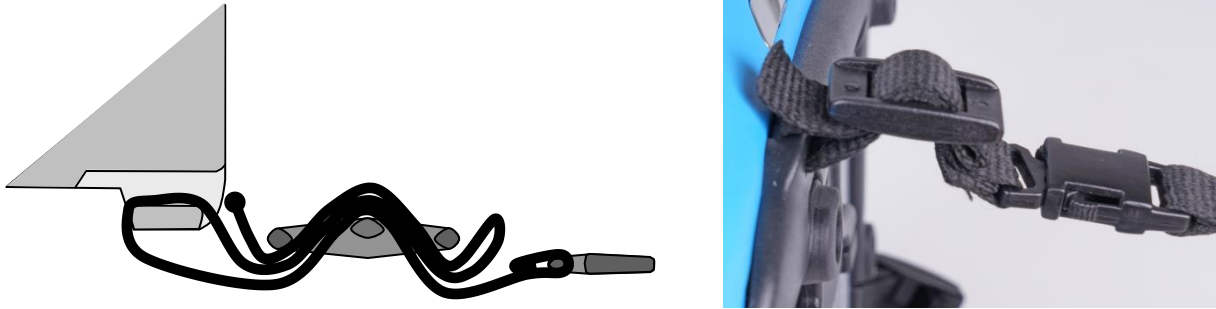

Figure 3.7: Alternative method

Please perform a periodical check of the attachment.

4 Instrument operation

The EurotestXD instrument can be manipulated via a keypad or touch screen.

4.1 General meaning of keys

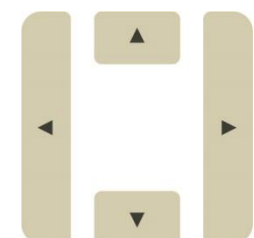

Cursor keys are used to:

- › select appropriate option.



Run key is used to:

- › confirm selected option;
- › start and stop measurements;
- › test PE potential.



Escape key is used to:

- › return to previous menu without changes;
- › abort measurements.



Option key is used to:

- › expand column in control panel.



Save key is used to:

- › store test results.



Auto Sequences® key is used as:

- › ... shortcut key to enter Auto Sequences® menu.



Single Tests key is used as:

- › shortcut key to enter Single Tests menu.



Memory Organizer key is used as:

- › shortcut key to enter Memory Organizer menu.



General Settings key is used to:

- › enter General Settings menu.



On / Off key is used to:

- › switch On / Off the instrument;
- › switch Off the instrument if pressed and held for 5 s.

4.2 General meaning of touch gestures



Tap (briefly touch surface with fingertip) is used to:

- › select appropriate option;
 - › confirm selected option;
 - › start and stop measurements.
-



Swipe (press, move, lift) up / down is used to:

- › scroll content in same level;
 - › navigate between views in same level.
-



long

Long press (touch surface with fingertip for at least 1 s) is used to:

- › select additional keys (virtual keyboard);
 - › enter cross selector from single test screens.
-



Tap Escape icon is used to:

- › return to previous menu without changes;
 - › abort measurements.
-

4.3 Virtual keyboard

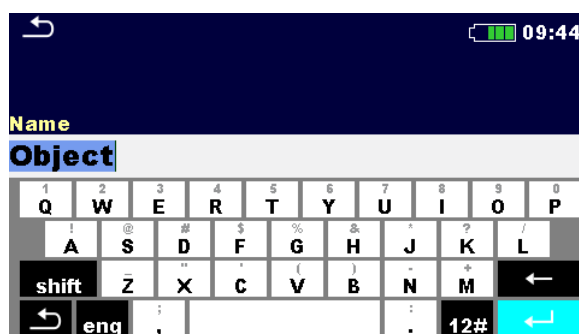











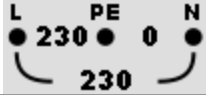
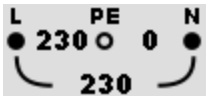
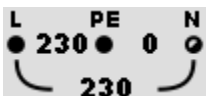
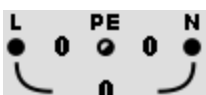
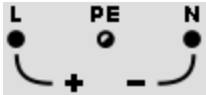
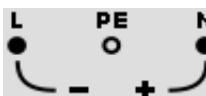
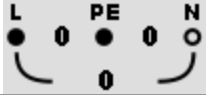
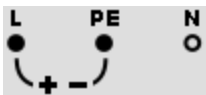
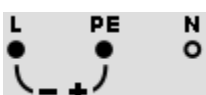
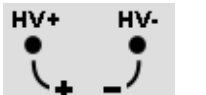

Figure 4.1: Virtual keyboard

	Toggle case between lowercase and uppercase. Active only when alphabetic characters keyboard layout selected.
	Backspace Clears last character or all characters if selected. (If held for 2 s, all characters are selected).
	Enter confirms new text.
	Activates numeric / symbols layout.
	Activates alphabetic characters.
	English keyboard layout.
	Greek keyboard layout.
	Russian keyboard layout.
	Returns to the previous menu without changes.

4.4 Display and sound

4.4.1 Terminal voltage monitor

The terminal voltage monitor displays on-line the voltages on the test terminals and information about active test terminals in the a.c. installation measuring mode.

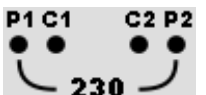
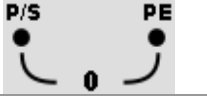
	Online voltages are displayed together with test terminal indication. All three test terminals are used for selected measurement.
	Online voltages are displayed together with test terminal indication. L and N test terminals are used for selected measurement.
	Online voltages are displayed together with test terminal indication. L and PE are active test terminals. N terminal should also be connected for correct input voltage condition.
	L and N are active test terminals. PE terminal should also be connected for correct input voltage condition.
	Polarity of test voltage applied to the output terminals, L and N.
	
	L and PE are active test terminals.
	Polarity of test voltage applied to the output terminals, L and PE.
	
	2.5 kV Insulation measurement terminal screen.
	4-wire test terminal indication.
	4-wire test terminal indication with online voltage between P1 and P2 probes.
	Test terminals for Discharging time measurement.

4.4.2 Battery indication

The battery indication indicates the charge condition of battery and connection of external power supply adapter.



Battery capacity indication.
Battery is in good condition.



Battery is full.



Low battery.
Battery is too weak to guarantee correct result. Replace or recharge the battery cells.



Empty battery or no battery.



Charging in progress (if power supply adapter is connected).



Charging finished.

4.4.3 Bluetooth



Bluetooth communication inactive.



Bluetooth communication active.

4.4.4 Measurement actions and messages



Conditions on the input terminals allow starting the measurement. Consider other displayed warnings and messages.



Conditions on the input terminals do not allow starting the measurement. Consider displayed warnings and messages.



Proceeds to next step of the measurement.



Stop the measurement.



Result(s) can be stored.



















Starts test leads compensation in Rlow / Continuity measurement.
Starts Zref line impedance measurement at origin of electrical installation in Voltage Drop measurement. Zref value is set to 0.00 Ω if pressing this touch key while instrument is not connected to a voltage source.









Alternates between A 1507 3-Phase Active Switch and Plug/Tip Commander.
This option is available only if A 1507 is enabled in Settings menu, see chapter **4.6.8.1 Adapters**.





Use A 1214 EASI Switch adapter for this test.





	Use A 1199 Specific earth resistance adapter for this test.
	Use MI 3143 Euro Z 440 V, MI 3144 Euro Z 800 V or A 1143 Euro Z 290 A adapter for this test.
	Use A 1172 or A 1173 Illumination sensor for this test.
	A 1507 3-Phase Active Switch not connected to the instrument. Connect A 1507 test cable to the instrument. Test / Measurement cannot be performed using A 1507.
	A 1507 3-Phase Active Switch connected to the instrument via test cable and Bluetooth communication. Test / Measurement can be performed using A 1507.
	Count down timer (in seconds) within measurement.
	Measurement is running, consider displayed warnings.
	RCD tripped-out during the measurement (in RCD functions).
	Instrument is overheated. The measurement is prohibited until the temperature decreases under the allowed limit.
	High electrical noise was detected during measurement. Results may be impaired. Indication of noise voltage above 5 V between H and E terminals during earth resistance measurement.
	L and N are changed. In most instrument profiles L and N test terminals are reversed automatically according to detected voltages on input terminal. In instrument profiles for countries where the position of phase and neutral connector is defined the selected feature is not working.
	Warning! High voltage is applied to the test terminals. The instrument automatically discharge tested object after finished insulation measurement. When an insulation resistance measurement has been performed on a capacitive object, automatic discharge may not be done immediately! The warning symbol and the actual voltage are displayed during discharge until voltage drops below 30 V.
	Warning! Dangerous voltage on the PE terminal! Stop the activity immediately and eliminate the fault / connection problem before proceeding with any activity! Continuous sound warning and yellow coloured screen is also present.
	Test leads resistance in R low / Continuity measurement is not compensated.
	Test leads resistance in R low / Continuity measurement is compensated.
	High resistance to earth of current test probes. Results may be impaired.

	High resistance to earth of potential test probes. Results may be impaired.
	High resistance to earth of potential and current test probes. Results may be impaired.
	Too small current for declared accuracy. Results may be impaired. Check in Current Clamp Settings if sensitivity of current clamp can be increased. In Earth 2 Clamp measurement results are very accurate for resistances below 10 Ω. At higher values (several 10 Ω) the test current drops to few mA. The measuring accuracy for small currents and immunity against noise currents must be considered!
	Measured signal is out of range (clipped). Results are impaired.
	Single fault condition in IT system.
	Fuse F1 is broken.

4.4.5 Result indication

	Measurement result is inside pre-set limits (PASS).
	Measurement result is out of pre-set limits (FAIL).
	Measurement is aborted. Consider displayed warnings and messages. RCD t and RCD I measurements will only be performed if the contact voltage in the pre-test at nominal differential current is lower than the set contact voltage limit!

4.4.6 Auto Sequence® result indication

	All Auto Sequence® results are inside pre-set limits (PASS).
	One or more Auto Sequence® results are out of pre-set limits (FAIL).
	Overall Auto Sequence® result without PASS/FAIL indication
	Overall Auto Sequence® result with empty (aborted) single tests



Measurement result is inside pre-set limits (PASS).



Measurement result is out of pre-set limits (FAIL).



Measurement result without PASS / FAIL indication.



Measurement not performed.

4.5 Instruments main menu

From the **Main menu** different main operation menus can be selected.

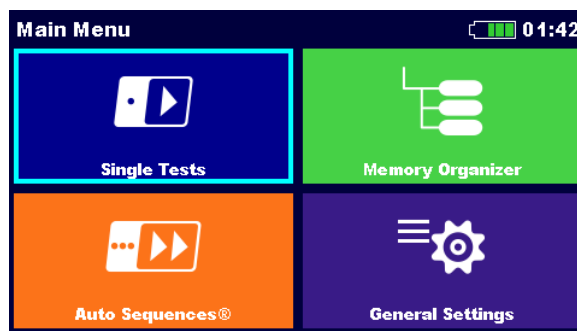



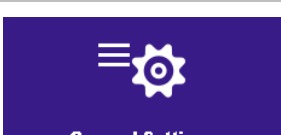

Figure 4.2: Main menu

Options

	Single Tests Menu with single tests, see chapter 6 Single tests .
	Auto Sequences® Menu with customized test sequences, see chapter 8 Auto Sequences® .
	Memory Organizer Menu for working with and documentation of test data, see chapter 5 Memory Organizer .
	General Settings Menu for setup of the instrument, see chapter 4.6 General Settings .

4.6 General Settings

In the **General settings menu** general parameters and settings of the instrument can be viewed or set.

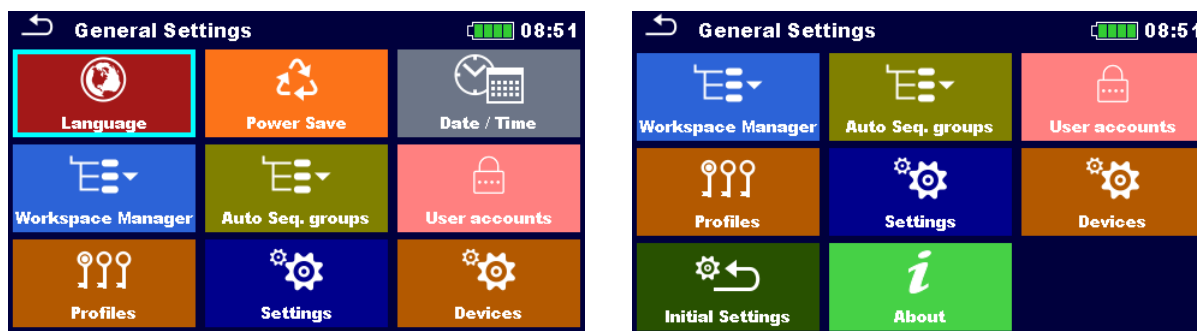

Figure 4.3: General settings menu

Options



Language
Instrument language selection.



Power Save
Brightness of LCD, enabling/disabling Bluetooth communication.



Date /Time
Instruments Date and time.



Workspace Manager
Manipulation with project files. Refer to chapter **4.8 Workspace Manager** for more information.



Auto Sequences® groups
Manipulation with lists of Auto Sequences®. Refer to chapter **4.9 Auto Sequence® groups** for more information.

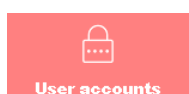

User accounts
User accounts settings. Refer to chapter **4.6.6 User accounts** for more information.



Instrument Profile
Selection of available instrument profiles. Refer to chapter **4.7 Instrument profiles** for more information.



Settings
Refer to chapter **4.6.8 Settings** for more information.



Devices
Selection of external devices. Refer to chapter **4.6.9 Devices** for more information.



Initial Settings
Factory settings.



About
Instrument info.

4.6.1 Language

In this menu the language of the instrument can be set.



Figure 4.4: Language menu

4.6.2 Power Save

In this menu different options for decreasing power consumption can be set.

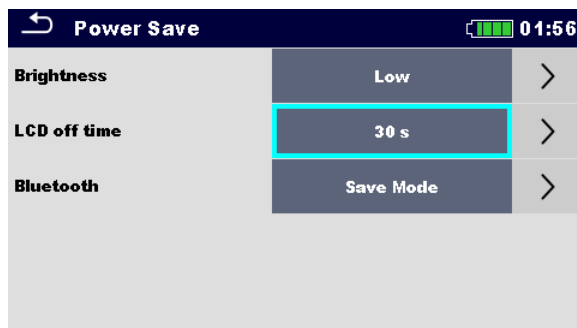

Figure 4.5: Power save menu

Brightness	Setting level of LCD brightness level. Power saving at low level: approx. 15%
LCD off time	Setting LCD off after set time interval. LCD is switched on after pressing any key or touching the LCD. Power saving at LCD off (at low level brightness): approx. 20%
Bluetooth	Always On: Bluetooth module is ready to communicate. Save mode: Bluetooth module is set to sleep mode and is not functioning. Power saving in Save mode: 7 %

4.6.3 Date and time

In this menu date and time of the instrument can be set.

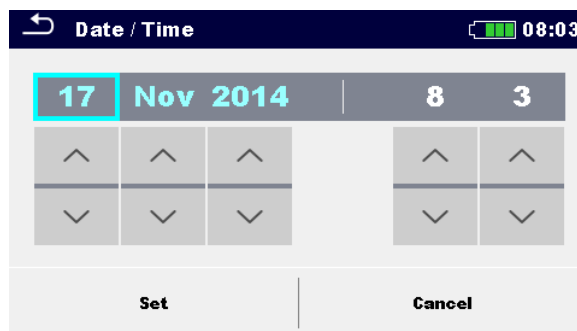

Figure 4.6: Setting date and time

Note:

- › If the batteries are removed, the set date and time will be lost.

4.6.4 Workspace manager

Refer to chapter **4.8 Workspace Manager** for more information.

4.6.5 Auto Sequence® groups

Refer to chapter **4.9 Auto Sequence® groups** for more information.

4.6.6 User accounts

The demand to sign in can prevent from unauthorized persons to work with the instrument. In this menu user accounts can be managed:

- Setting if signing in to work with the instrument is required or not.
- Adding and deleting new users, setting their user names and passwords.

The user accounts can be managed by the administrator.

Factory set administrator password: ADMIN

It is recommended to change factory set administrator password after first use. If the custom password is forgotten the second administrator password can be used. This password always unlocks the Account manager and is delivered with the instrument.

If a user account is set and the user is signed in the user's name will be stored in memory for each measurement.

Individual users can change their passwords.

4.6.6.1 Signing in

If signing in is demanded the user must enter the password in order to work with the instrument.

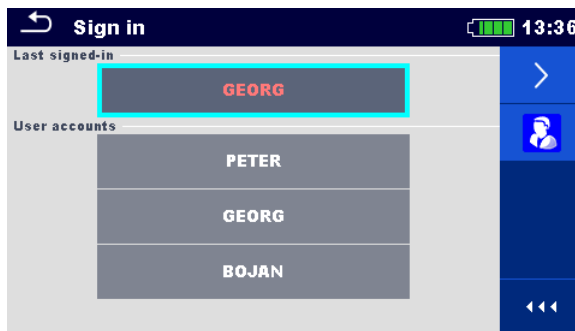
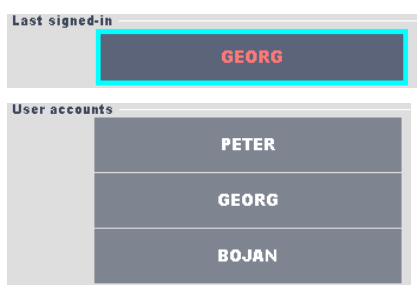

Figure 4.7: Sign in menu

Options

User signing in



The user should be selected first.
The last used user is displayed in the first row.



Sign in with selected user name.

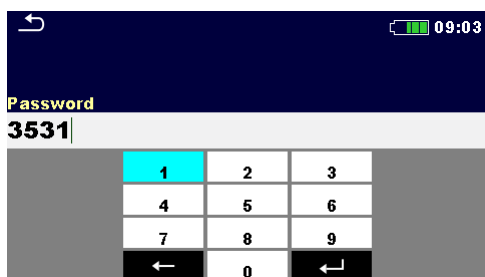

Enter the password and confirm.
The user password consists of an up to 4 digit number.

Administrator signing in



The Account manager menu is accessed by selecting Account manager in Sign in menu or User profile menu.

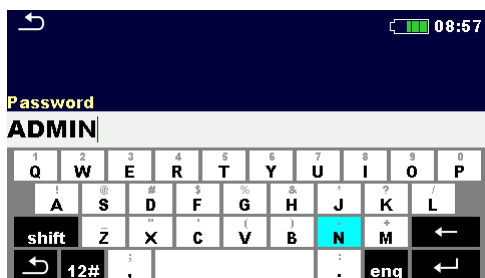

The account manager password must be entered and confirmed first.
Administrator password consists of letters and/or numbers. Letters are case sensitive.
The default password is ADMIN.

4.6.6.2 Changing user password, signing out

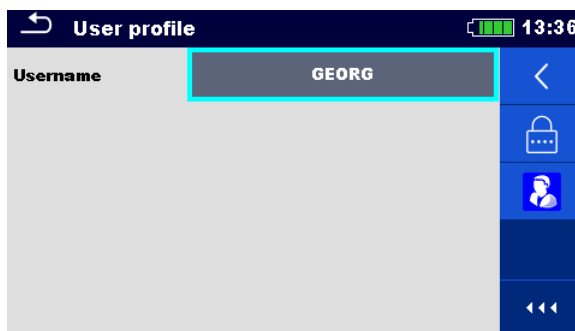

Figure 4.8: User profile menu

Options



Signs out the set user.



Enters procedure for changing the user's password.

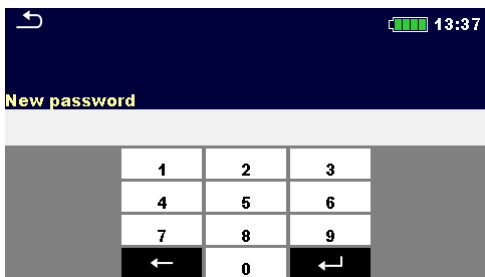

The user can change its password. The actual password must be entered first followed by the new password.



Enters the Account manager menu.

4.6.6.3 Managing accounts

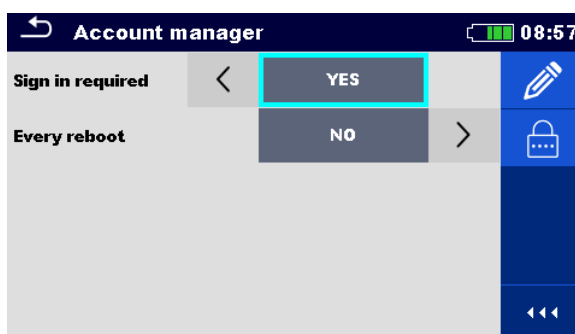
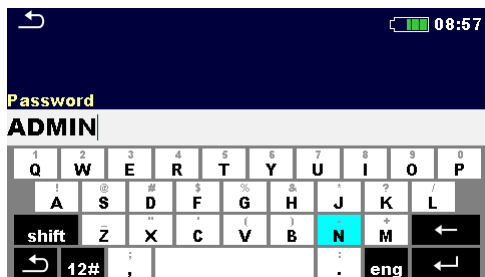

Figure 4.9: Account manager menu

Options



The Account manager menu is accessed by selecting Account manager in Sign in menu or User profile menu.



The account manager password must be entered and confirmed first.

The default password is ADMIN.

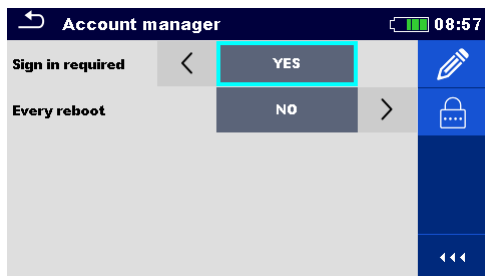

Field for setting if signing in is required to work with the instrument.

Field for setting if signing is required once or at each power on of the instrument.



Enters procedure for changing the account manager (administrator) password.

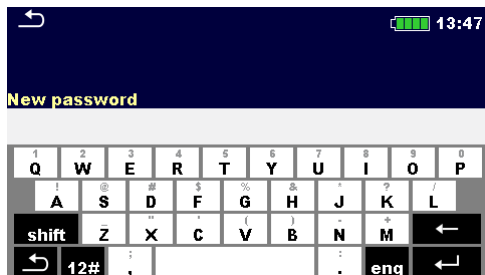

To change the password the actual and then the new password should be entered and confirmed.



Enters menu for editing user accounts.

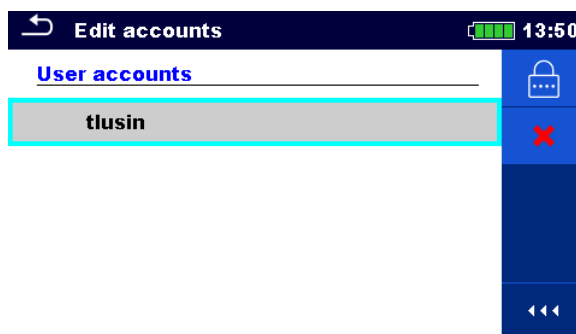
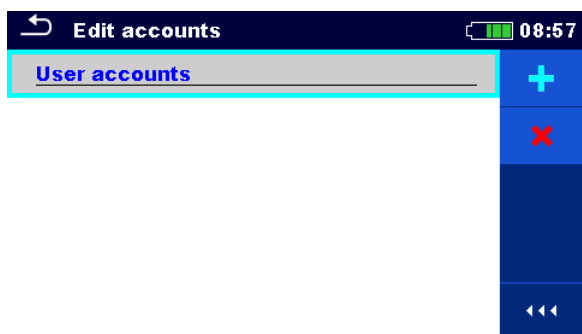
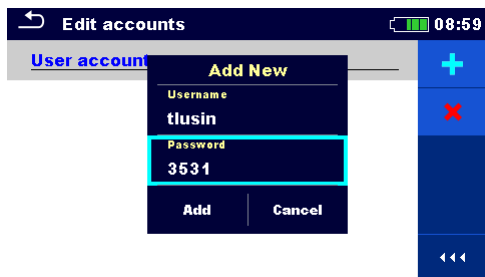

Figure 4.10: Edit accounts menu

Options



Opens the window for adding a new user.



In the Add New window, the name and initial password of the new user account are to be set. 'Add' confirms the new user data.



Changes password of the selected user account.

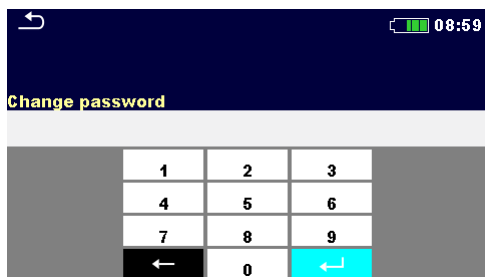

Deletes all user accounts.
Deletes the selected user account.

4.6.6.4 Setting Blackbox password

Blackbox password can be set by administrator from the Account manager menu. Set Blackbox password is valid for all users. Default Blackbox password is empty (disabled).

Options

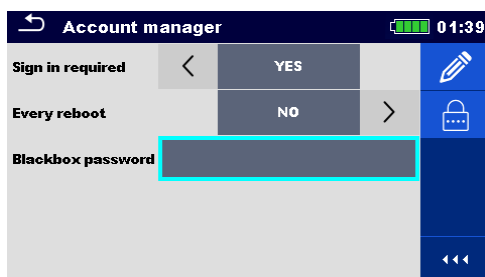

Add or edit Blackbox password. Enter to modify.

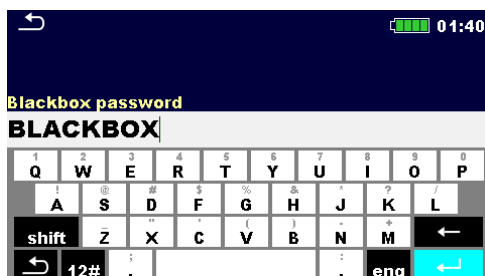

Keyboard for entering new Blackbox password is opened. Empty string disables password. Confirm entry.

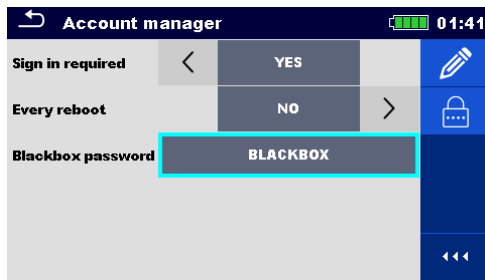

Blackbox password is changed.

4.6.7 Profiles

Refer to chapter **4.7 Instrument profiles** for more information.

4.6.8 Settings

In this menu different general parameters can be set.

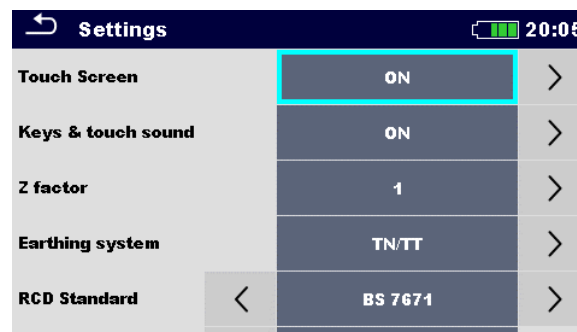

Figure 4.11: Settings menu

	Available selection	Description
Touch screen	[ON, OFF]	Enables / disables operation with touch screen.
Keys & touch sound	[ON, OFF]	Enables / disables sound when touch screen or key is pressed.
Z factor	[Custom, 1, 0.80] Default value: 0.80	Impedance correction scaling factor. The value should be set according to local regulative.
Earthing system	[TN/TT, IT]	Terminal voltage monitor and measuring functions are suited to selected earthing system. In some measuring functions the results and parameters are suited to the selected system.

	Available selection	Description
RCD Standard	[EN 61008 / EN 61009, IEC 60364-4-41 TN/IT, IEC 60364-4-41 TT, BS 7671, AS/NZS 3017, VDE 0664, VDE 0100-410 TN/IT, VDE 0100-410 TT]	Used standards for RCD tests. Refer to the end of this chapter for more information.
EV RCD/RCM Standards	[IEC 62752, IEC 62955]	Used standards for EV RCD, MI RCD and EV RCM tests.
Length Unit	[m, ft]	Length unit for specific earth resistance measurement.
Ch1 clamp type	[A 1018, A 1019, A1391]	Model of current clamp adapter.
Range	A 1018: [20 A] A1019: [20 A] A 1391: [40 A, 300 A]	Measuring range of selected current clamp adapter. Measuring range of the instrument must be considered. Measurement range of current clamp adaptor can be higher than of the instrument.
Merge fuses	[yes, no]	[Yes]: fuse type and parameters set in one function are also kept for other functions! [No]: Fuse parameters will be considered only in function where they have been set.
External Device	[None, Commander]	The 'None' option is also intended to disable the commander's remote keys. In case of high EM interfering noise the operation of the commander can be irregular.
Ignore PE warning (IT)	[yes, no]	[yes]: In IT earthing system the instrument will allow to start the selected measurement regardless of PE warning detection. [no], In IT earthing system the instrument will block the selected measurement if PE warning is detected.
Uc pretest (IT)	[yes, no]	[yes]: In IT earthing system the instrument will inhibit the selected measurement if result exceed set Uc limit. [no]: In IT earthing system the instrument will present warning message, if result exceed set Uc limit; operator should confirm to proceed with selected measurement
IscMax, IscMin calculation	[yes, no]	[yes]: IscMax, IscMin calculation is enabled in Z line measurement. [no]: IscMax, IscMin calculation is disabled in Z line measurement.
Load pretest	[yes, no]	[yes]: Load pretest is enabled in Riso and Riso-all measurements. [no]: Load pretest is disabled.
External Device	[None, Commander, A 1507]	[None]: This option is intended to disable the commander's remote keys. In case of high

	Available selection	Description
		EM interfering noise, the operation of the commander can be irregular. [Commander]: Working with commander enabled. [A 1507]: Working with 3-phase active switch enabled.
Limit Uc	[Custom, 12 V, 25 V, 50 V]	Contact voltage limit.

4.6.8.1 Adapters

Settings menu provide selection and configuration of Metrel measuring adapters to perform supported tests and measurements. See **Appendix F** for details on available Metrel adapters and supported tests.

	Available selection	Description
Adapter type	[none, selected adapter]	Selection from list of available adapters.
Port	[RS232, Bluetooth]	Sets communication port of selected measuring adapter. See chapter 9.3 Communication with adapters for more details.
Bluetooth device name	Name of selected adapter	After searching is finished, list of all available Bluetooth devices is presented. Pair the instrument with selected measuring adapter.

4.6.8.2 RCD standard

Maximum RCD disconnection times differ in various standards. The trip-out times defined in individual standards are listed below.

	$\frac{1}{2} \times I_{\Delta N}^{1)}$	$I_{\Delta N}$	$2 \times I_{\Delta N}$	$5 \times I_{\Delta N}$
General RCDs (non-delayed)	$t_{\Delta} > 300$ ms	$t_{\Delta} < 300$ ms	$t_{\Delta} < 150$ ms	$t_{\Delta} < 40$ ms
Selective RCDs (time-delayed)	$t_{\Delta} > 500$ ms	130 ms $< t_{\Delta} < 500$ ms	60 ms $< t_{\Delta} < 200$ ms	50 ms $< t_{\Delta} < 150$ ms

Table 4.1: Trip-out times according to EN 61008 / EN 61009

Test according to standard IEC/HD 60364-4-41 has two selectable options:

- IEC 60364-4-41 TN/IT and
- IEC 60364-4-41 TT

The options differ to maximum disconnection times as defined in IEC/HD 60364-4-41 Table 41.1.

	$U_0^{3)}$	$\frac{1}{2} \times I_{\Delta N}^{1)}$	$I_{\Delta N}$	$2 \times I_{\Delta N}$	$5 \times I_{\Delta N}$
TN / IT	≤ 120 V	$t_{\Delta} > 800$ ms	$t_{\Delta} \leq 800$ ms	$t_{\Delta} < 150$ ms	$t_{\Delta} < 40$ ms
	≤ 230 V	$t_{\Delta} > 400$ ms	$t_{\Delta} \leq 400$ ms		
TT	≤ 120 V	$t_{\Delta} > 300$ ms	$t_{\Delta} \leq 300$ ms		
	≤ 230 V	$t_{\Delta} > 200$ ms	$t_{\Delta} \leq 200$ ms		

Table 4.2: Trip-out times according to IEC/HD 60364-4-41

	$\frac{1}{2} \times I_{\Delta N}^{1)}$	$I_{\Delta N}$	$2 \times I_{\Delta N}$	$5 \times I_{\Delta N}$
General RCDs (non-delayed)	$t_{\Delta} > 1999$ ms	$t_{\Delta} < 300$ ms	$t_{\Delta} < 150$ ms	$t_{\Delta} < 40$ ms
Selective RCDs (time-delayed)	$t_{\Delta} > 1999$ ms	$130 \text{ ms} < t_{\Delta} < 500$ ms	$60 \text{ ms} < t_{\Delta} < 200$ ms	$50 \text{ ms} < t_{\Delta} < 150$ ms

Table 4.3: Trip-out times according to BS 7671

RCD type	$I_{\Delta N}$ (mA)	$\frac{1}{2} \times I_{\Delta N}^{1)}$ t_{Δ}	$I_{\Delta N}$ t_{Δ}	$2 \times I_{\Delta N}$ t_{Δ}	$5 \times I_{\Delta N}$ t_{Δ}	Note
I	≤ 10		40 ms	40 ms	40 ms	Maximum break time
II	$> 10 \leq 30$	> 999 ms	300 ms	150 ms	40 ms	
III	> 30		300 ms	150 ms	40 ms	
IV S	> 30	> 999 ms	500 ms 130 ms	200 ms 60 ms	150 ms 50 ms	Minimum non-actuating time

Table 4.4: Trip-out times according to AS/NZS 3017²⁾

Standard	$\frac{1}{2} \times I_{\Delta N}$	$I_{\Delta N}$	$2 \times I_{\Delta N}$	$5 \times I_{\Delta N}$
EN 61008 / EN 61009	300 ms	300 ms	150 ms	40 ms
IEC 60364-4-41	1000 ms	1000 ms	150 ms	40 ms
BS 7671	2000 ms	300 ms	150 ms	40 ms
AS/NZS 3017 (I, II, III)	1000 ms	1000 ms	150 ms	40 ms

Table 4.5: Maximum test times related to selected test current for general (non-delayed) RCD

Standard	$\frac{1}{2} \times I_{\Delta N}$	$I_{\Delta N}$	$2 \times I_{\Delta N}$	$5 \times I_{\Delta N}$
EN 61008 / EN 61009	500 ms	500 ms	200 ms	150 ms
IEC 60364-4-41	1000 ms	1000 ms	150 ms	40 ms
BS 7671	2000 ms	500 ms	200 ms	150 ms
AS/NZS 3017 (IV)	1000 ms	1000 ms	200 ms	150 ms

Table 4.6: Maximum test times related to selected test current for selective (time-delayed) RCD

¹⁾ Minimum test period for current of $\frac{1}{2} \times I_{\Delta N}$, RCD shall not trip-out.

²⁾ Test current and measurement accuracy correspond to AS/NZS 3017 requirements.

³⁾ U_0 is nominal U_{LPE} voltage.

Notes:

- › Trip-out limit times for PRCD, PRCD-K and PRCD-S are equal to General (non-delayed) RCDs.
- › The trip-out times of VDE 0664 are equal to trip-out times of EN 61008 / EN 61009.
- › The trip-out times of VDE 0100-410 TN/IT are equal to trip-out times of IEC 60364-4-41 TN/IT.
- › The trip-out times of VDE 0100-410 TT are equal to trip-out times of IEC 60364-4-41 TT.

4.6.8.3 EV RCD/RCM standards

Supported standards:

- IEC 62752:2016** In-cable control and protection device for mode 2 charging of electric road vehicles (IC-CPD)
- IEC 62955:2018** Residual direct current detecting device (RDC-DD) to be used for mode 3 charging of electric vehicles

Standard	6 mA (1 × I _{ΔN})	60 mA (10 × I _{ΔN})	200 mA (33 × I _{ΔN})	300 mA (50 × I _{ΔN})
IEC 62955 ¹⁾	< 10.0 s	< 300 ms	< 100 ms	×
IEC 62752 ²⁾	< 10.0 s	< 300 ms	×	< 40 ms

Table 4.7: Break times for d.c. residual currents

- 1) IEC 62955: Table 2 – Maximum values of break times for residual direct currents
- 2) IEC 62752: Table 3 – Limit values of break time for smooth d.c. residual currents

Standard	30 mA (1 × I _{ΔN})	60 mA (2 × I _{ΔN})	150 mA (5 × I _{ΔN})
IEC 62752 ³⁾	< 300 ms	< 150 ms	< 40 ms

Table 4.8: Break times for a.c. residual currents

- 3) IEC 62752: Table 2 – Limit values of break time for a.c. residual currents at rated frequency

Standard	Up to 30 mA (1 × I _{ΔN})	60 mA (2 × I _{ΔN})	150 mA (5 × I _{ΔN})
IEC 62955 ⁴⁾	No tripping	> 300 ms	> 80 ms

Table 4.9: Non-operating times for a.c. residual currents

- 4) IEC 62955: Table 3 – Minimum values of non-operating time for alternating residual currents (RMS values)

4.6.9 Devices

In this menu operation with external devices is configured.

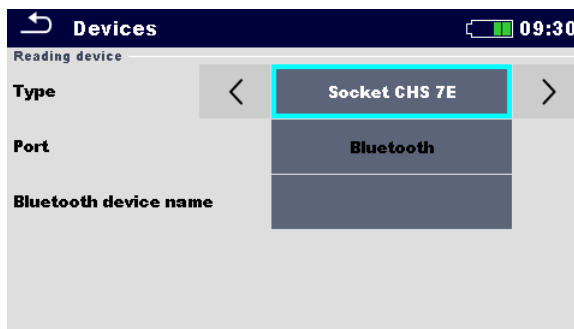

Figure 4.12: Device settings menu

Reading devices

Type	Sets appropriate reading device (QR or barcode scanner, RFID reader, via aMESM application).
Port	Sets communication port of selected reading device.
Bluetooth device name	Goes to menu for pairing with selected Bluetooth device.

4.6.10 Initial Settings

In this menu the instrument settings, measurement parameters and limits can be set to initial (factory) values.

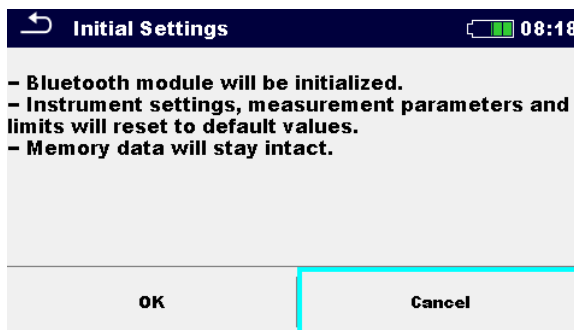

Figure 4.13: Initial settings menu

Warning!

Following customized settings will be lost when setting the instruments to initial settings:

- › measurement limits and parameters,
- › global parameters, system settings, and Devices in General settings menu,
- › opened Workspace and Auto Sequences® group will be deselected,
- › user will be signed out.
- › If the battery pack is removed the custom made settings will be lost.

Note:

Following customized settings will stay:

- › profile settings,

- data in memory (Data in memory organizer, Workspaces, Auto Sequence® groups, Auto Sequences®) and
- user accounts.

4.6.11 About

In this menu instrument data (name, serial number, firmware (FW) and hardware (HW) version, fuse version and date of calibration) can be viewed.



Name	MI 3155 EurotestXD
S/N	17120430
FW version	0.8.8.8256 - ATAB
HW version	1.0
Fuse version	1.06
Date of calibration	11.May.2017

Figure 4.14: Instrument info screen

4.7 Instrument profiles

In this menu the instrument profile can be selected from the available ones.

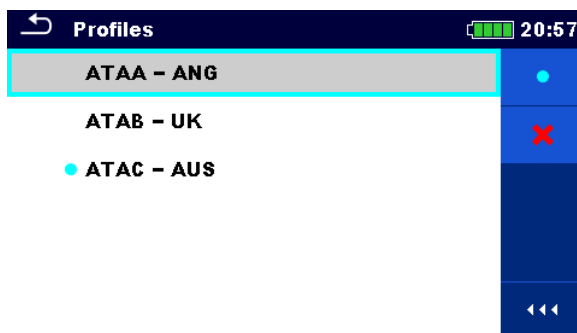

Figure 4.15: Instrument profiles menu

The instrument uses different specific system and measuring settings in regard to the scope of work or country it is used. These specific settings are stored in instrument profiles.

By default, each instrument has at least one profile activated. Proper licence keys must be obtained to add more profiles to the instruments.

If different profiles are available, they can be selected in this menu.

Options

	Loads the selected profile. The instrument will restart automatically with new profile loaded.
	Deletes the selected profile.
	Before deleting the selected profile, user is asked for confirmation.
	Opens more options in control panel / expands column.

4.8 Workspace Manager

The Workspace Manager is intended to manage with different Workspaces and Exports that are stored on the SD memory card.

4.8.1 Workspaces and Exports

The works with MI 3155 EurotestXD can be organized and structured with help of Workspaces and Exports. Exports and Workspaces contain all relevant data (measurements, parameters, limits, structure objects) of an individual work.

Workspaces are stored on SD card on directory WORKSPACES, while Exports are stored on directory EXPORTS. Export files can be read by METREL applications that run on other devices. Exports are suitable for making backups of important works. To work on the instrument an Export should be imported first from the list of Exports and converted to a Workspace. To be stored as Export data a Workspace should be exported first from the list of Workspaces and converted to an Export.

4.8.2 Workspace Manager main menu

In Workspace manager Workspaces and Exports are displayed in two separated lists.

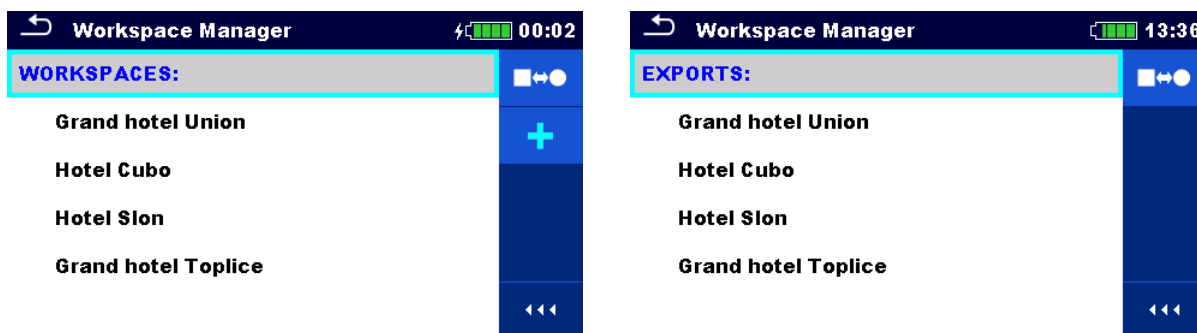

Figure 4.16: Workspace manager menu

Options

	List of Workspaces.
	Displays a list of Exports.
	Adds a new Workspace. Refer to chapter 4.8.5 Adding a new Workspace for more information.
	List of Exports.
	Displays a list of Workspaces.

4.8.3 Operations with Workspaces

Only one Workspace can be opened in the instrument at the same time. The Workspace selected in the Workspace Manager will be opened in the Memory Organizer.

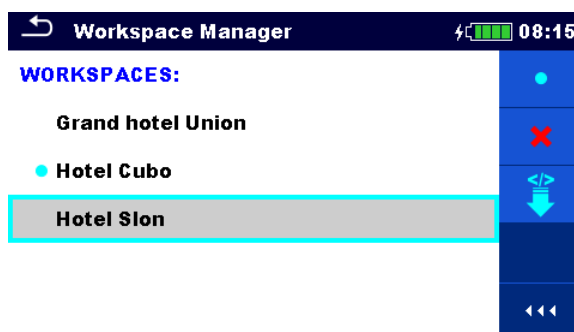

Figure 4.17: Workspaces menu

Options



Marks the opened Workspace in Memory Organizer.
Opens the selected Workspace in Memory Organizer.
Refer to chapter **4.8.6 Opening a Workspace** for more information.



Deletes the selected Workspace.
Refer to chapter **4.8.7 Deleting a Workspace / Export** for more information.



Adds a new Workspace.
Refer to chapter **4.8.5 Adding a new Workspace** for more information.



Exports a Workspace to an Export.
Refer to **4.8.9 Exporting a Workspace** for more information.

4.8.4 Operations with Exports



Figure 4.18: Workspace manager Exports menu

Options





Deletes the selected Export.
Refer to chapter **4.8.7 Deleting a Workspace / Export** for more information.



Imports a new Workspace from Export.
Refer to **4.8.8 Importing a Workspace** for more information.

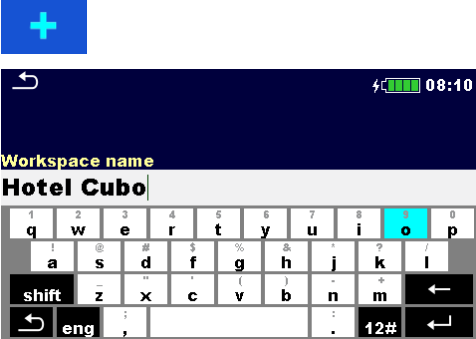

4.8.5 Adding a new Workspace

Procedure

<p>① </p>	<p>New Workspaces can be added from the Workspace Manager screen.</p>
<p>② </p>	<p>Enters option for adding a new Workspace. Keypad for entering name of a new Workspace is displayed after selecting New.</p>
<p>③ </p>	<p>After confirmation a new Workspace is added in the list in Main Workspace Manager menu.</p>

4.8.6 Opening a Workspace

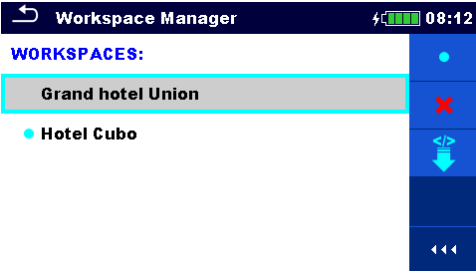
Procedure

<p>① </p>	<p>Workspace can be selected from a list in Workspace manager screen.</p>
<p>② </p>	<p>Opens a Workspace in Workspace manager.</p>

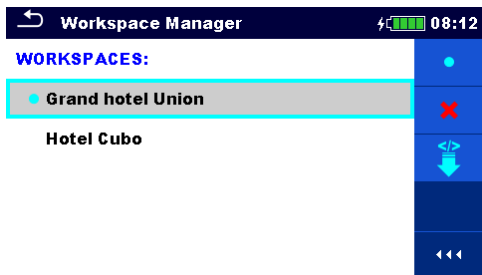

The opened Workspace is marked with a blue dot. The previously opened Workspace will close automatically.

4.8.7 Deleting a Workspace / Export

Procedure



Workspace / Export to be deleted should be selected from the list of Workspaces / Exports.
Opened workspace can't be deleted.

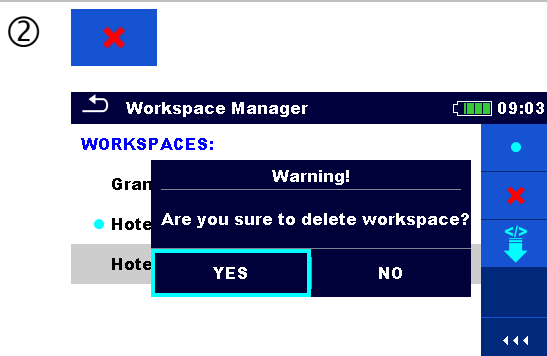

Enters option for deleting a Workspace / Export.
Before deleting the selected Workspace / Export the user is asked for confirmation.



Workspace / Export is deleted from the Workspace / Export list.

4.8.8 Importing a Workspace

Procedure



Select an Export file to be imported from Workspace manager Export list.



Enters option Import.

Before the import of the selected Export file the user is asked for confirmation.



The imported Export file is added to the list of Workspaces.

Note:

If a Workspace with the same name already exists the name of the imported Workspace will be changed (name_001, name_002, name_003, ...).

4.8.9 Exporting a Workspace

Procedure

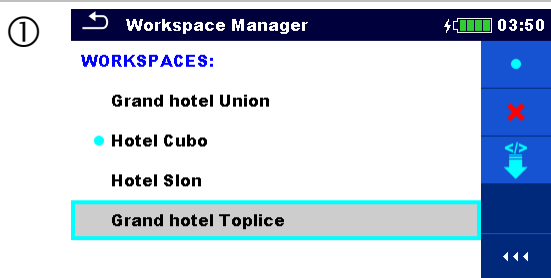

Select a Workspace from Workspace manager list to be exported to an Export file.

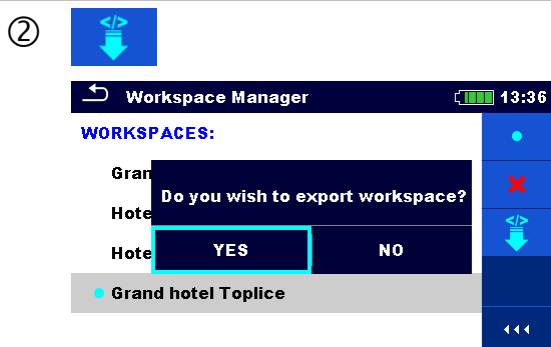

Enters option Export.

Before exporting the selected Workspace the user is asked for confirmation.

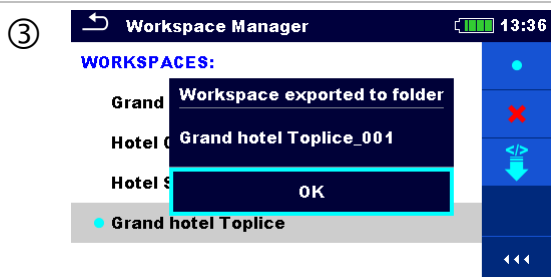

Workspace is exported to Export file and is added to the list of Exports.

Note:

If an Export file with the same name already exists the name of the Export file will be changed (name_001, name_002, name_003 ...).

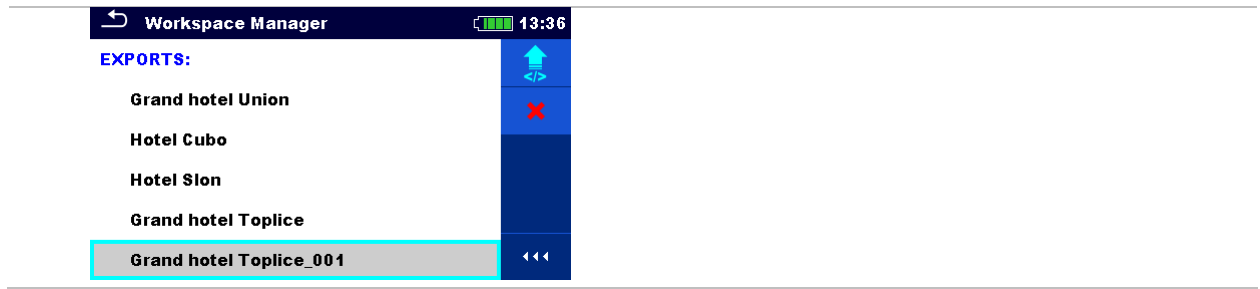

4.9 Auto Sequence® groups

The Auto Sequences® in MI 3155 EurotestXD can be organized by using lists. In a list a group of similar Auto Sequences® is stored. The Auto Sequence® groups menu is intended to manage with different lists of Auto Sequences® that are stored on the SD card.

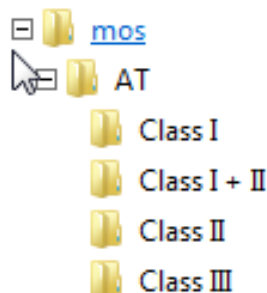

Figure 4.19: Organization of Auto Sequences® on SD card

Folders with lists of Auto Sequences® are stored in *Root__MOS__\AT* on the SD card.

4.9.1 Auto Sequence® groups menu

In Auto Sequence® groups menu lists of Auto Sequences® are displayed. Only one list can be opened in the instrument at the same time. The list selected in the Auto Sequence® groups menu will be opened in the Auto Sequences® main menu.

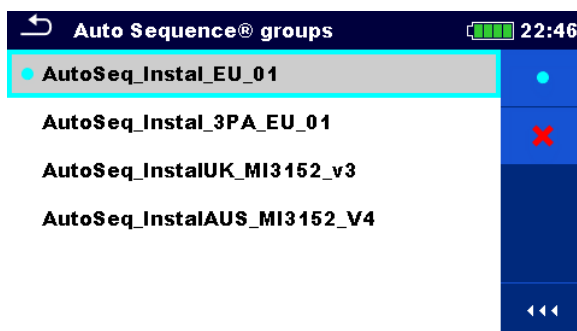

Figure 4.20: Auto Sequences® groups menu

Operations in Auto Sequences® groups menu



Opens the selected list of Auto Sequences®. Previously selected list of Auto Sequences® will be closed automatically.

Refer to chapter **4.9.1.1 Selecting a list of Auto Sequences®** for more information.



Deletes the selected list of Auto Sequences®.

Refer to chapter **4.9.1.2 Deleting a list of Auto** for more information.



Opens options in control panel / expands column.

4.9.1.1 Selecting a list of Auto Sequences®

Procedure

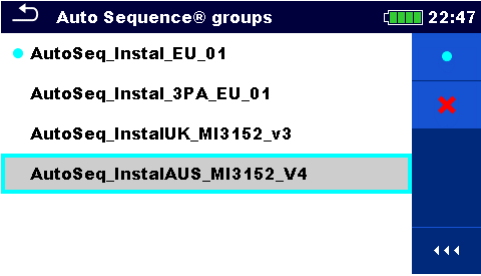
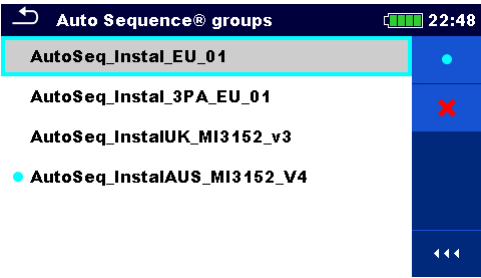
<p>①</p>		<p>A list of Auto Sequences® can be selected from the Auto Sequence® groups menu.</p>
<p>②</p>		<p>Enters option for selecting active Auto Sequences® list.</p> <p>Selected list of Auto Sequences® is marked with a blue dot.</p> <p>Note: Previously selected list of Auto Sequences® is closed automatically.</p>

4.9.1.2 Deleting a list of Auto Sequences®

Procedure

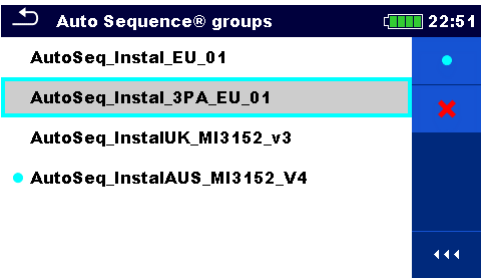
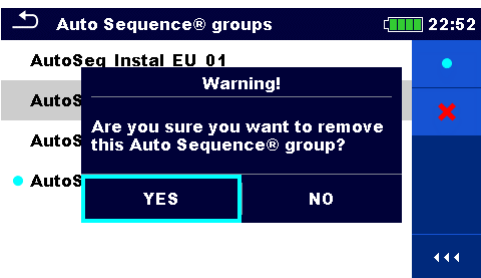
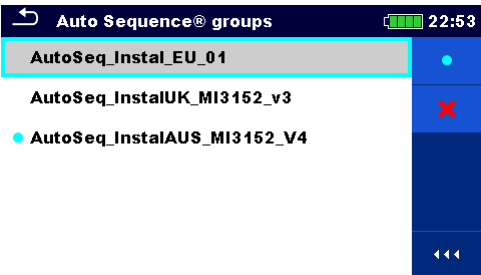
<p>①</p>		<p>A list of Auto Sequences® to be deleted can be selected from the Auto Sequence® groups menu.</p>
<p>②</p>		<p>Enters option for deleting a list.</p> <p>Before deleting the selected list of Auto Sequences®, the user is asked for confirmation.</p>
<p>③</p>		<p>A list of Auto Sequences® is removed.</p>

5 Memory Organizer

Memory Organizer is a tool for storing and working with test data.

5.1 Memory Organizer menu

The data is organized in a tree structure with Structure objects and Measurements. EurotestXD instrument has a multi-level structure. The hierarchy of Structure objects in the tree is shown on **Figure 5.1**. A list of available structure objects can be seen in **Appendix C – Structure objects**.

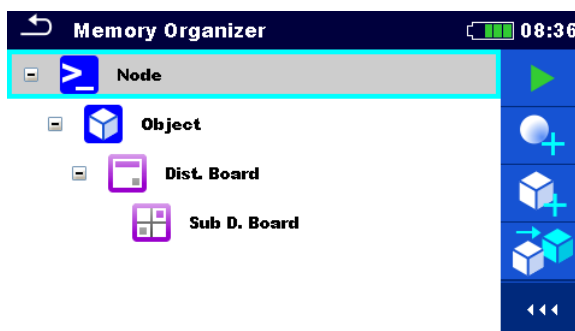

Figure 5.1: Default tree structure and its hierarchy

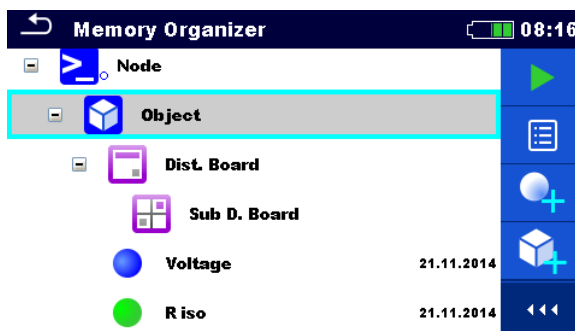

Figure 5.2: Example of a tree menu

5.1.1 Measurement statuses

Each measurement has:

- › a status (PASS or FAIL or no status),
- › a name,
- › results,
- › limits and parameters.









A measurement can be a Single test or an Auto Sequence®. For more information refer to chapters **7 Tests and measurements** and **8 Auto Sequences®**.

Statuses of Single tests

-
- passed finished single test with test results
-
- failed finished single test with test results
-
- finished single test with test results and no status
-

-
- empty single test without test results
-

Overall statuses of Auto Sequence®

		At least one single test in the Auto Sequence® passed and no single test failed
		At least one single test in the Auto Sequence® failed.
		At least one single test in the Auto Sequence® was carried out and there were no other passed or failed single tests.
		Empty Auto Auto Sequence® with empty single tests.

5.1.2 Structure Objects

Each Structure object has:

- › an icon,
- › a name and
- › parameters.

Optionally they can have:

- › an indication of the status of the measurements under the Structure object and
- › a comment or a file attached.



Figure 5.3: Structure object in tree menu

Structure objects supported by the instrument are described in **Appendix C – Structure objects**.

5.1.2.1 Measurement status indication under the Structure object

Overall status of measurements under each structure element /sub-element can be seen without spreading tree menu. This feature is useful for quick evaluation of test status and as guidance for measurements.

Options

 **Object** There are no measurement results under selected structure object. Measurements should be made.

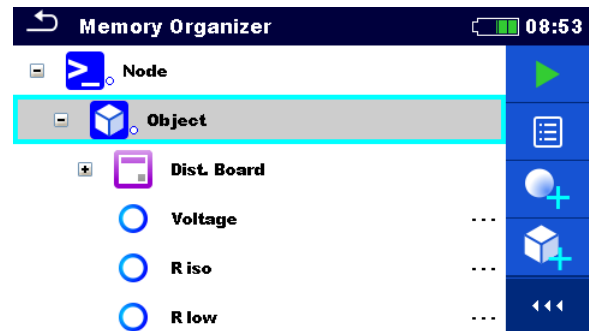

 **Object** One or more measurement result(s) under selected structure object has failed. Not all measurements under selected structure object have been made yet.

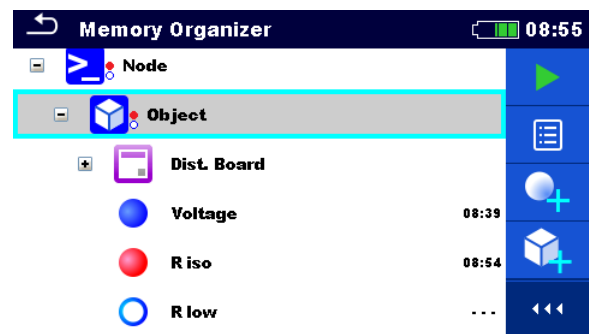

 **Object** All measurements under selected structure object are completed but one or more measurement result(s) has failed.

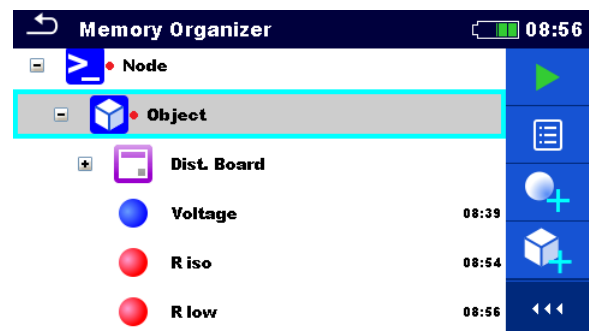





Note:

- There is no status indication if all measurement results under each structure element / sub-element have passed or if there is an empty structure element / sub-element (without measurements).

5.1.3 Selecting an active Workspace in Memory Organizer

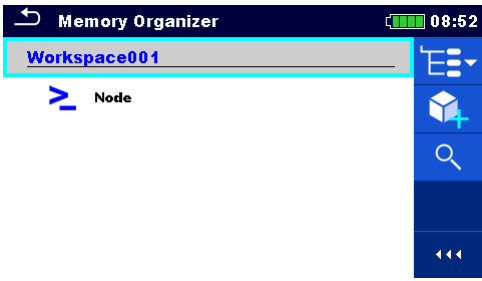
Memory Organizer and Workspace Manager are interconnected so an active Workspace can be selected also in the Memory Organizer menu.

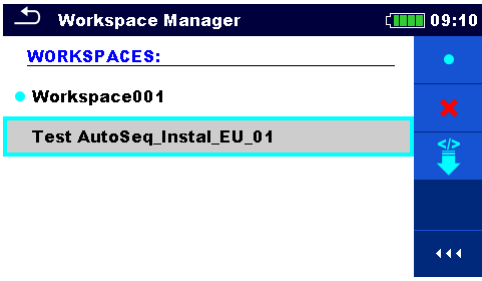

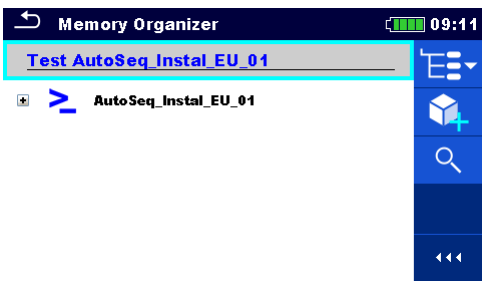
Procedure

-
- ①  Press the active Workspace in Memory Organizer Menu.
-
- ②  Select List of Workspaces in Control panel.
-
- ③  Choose desired Workspace from a list of Workspaces.
-
- ④  Use Select button to confirm selection.
-
- ⑤  New Workspace is selected and displayed on the screen.
-

5.1.4 Adding Nodes in Memory Organizer

Structural Elements (Nodes) are used to ease organization of data in the Memory Organizer. One Node is a must; others are optional and can be created or deleted freely.

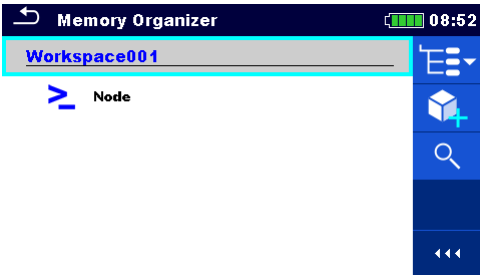
Procedure

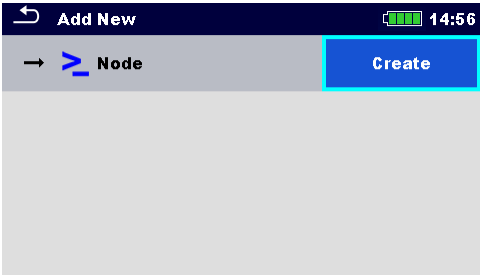
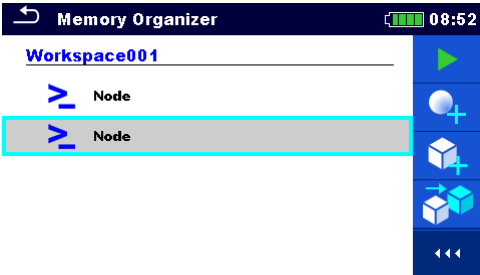
- | | | |
|---|---|--|
| ① |  | Press the active Workspace in Memory Organizer Menu. |
| ② |  | Select Add New Structure Element in Control panel. |
| ③ |  | Press "Create" to confirm. |
| ④ |  | <p>New Structure Element (Node) is added.</p> <p>Note:
To change the name of a Node, see chapter 5.1.5.14 Rename a Structure object.</p> |

5.1.5 Operations in Tree menu

In the Memory organizer different actions can be taken with help of the control panel at the right side of the display. Possible actions depend on the selected element in the organizer.

5.1.5.1 Operations on measurements (finished or empty measurements)

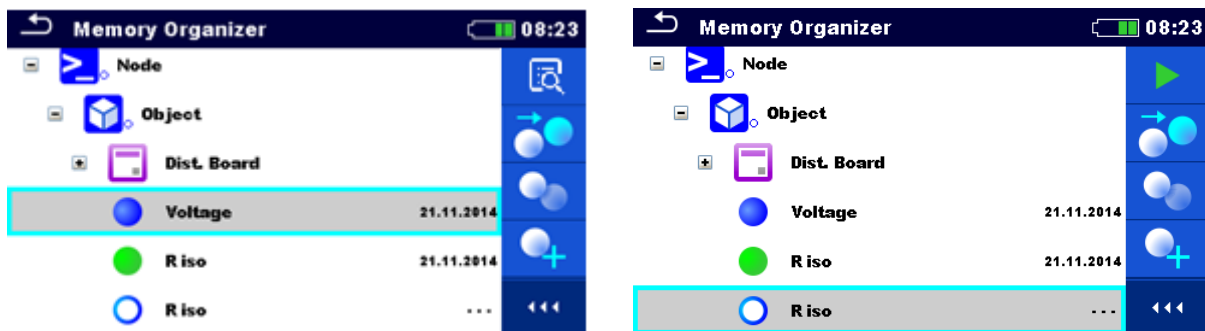

Figure 5.4: A measurement is selected in the Tree menu

Options



Views results of measurement.

The instrument goes to the measurement memory screen. Refer to chapter **6.1.9 Recall single test results screen** and **8.2.4 Auto Sequence® memory screen** for more information.



Starts a new measurement.

The instrument goes to the measurement start screen. Refer to chapter **6.1.3 Single test start screen** and **8.2.1 Auto Sequence® view menu** for more information.



Saves a measurement.

Saving of measurement on a position after the selected (empty or finished) measurement.



Clones the measurement.

The selected measurement can be copied as an empty measurement under the same Structure object. Refer to chapter **5.1.5.7 Clone a measurement** for more information.



Copies & Paste a measurement.

The selected measurement can be copied and pasted as an empty measurement to any location in structure tree. Multiple 'Paste' is allowed. Refer to chapter **5.1.5.10 Copy & Paste a measurement** for more information.



Adds a new measurement.

The instrument goes to the Menu for adding measurements. Refer to chapter **5.1.5.5 Add a new measurement** for more information.



Views and edit comments.

The instrument displays comment attached to the selected measurement or opens keypad for entering a new comment.



Deletes a measurement.

Selected Measurement can be deleted. User is asked for confirmation before the deleting. Refer to chapter **5.1.5.13 Delete a measurement** for more information.

5.1.5.2 Operations on Structure objects

The structure object must be selected first.

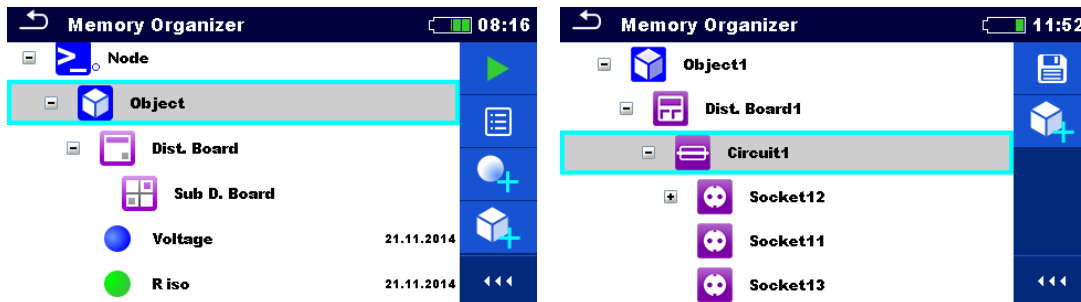

Figure 5.5: A structure object is selected in the Tree menu

Options



Starts a new measurement.
Type of measurement (Single test or Auto Sequence®) should be selected first. After proper type is selected, the instrument goes to Single Test or Auto Sequence® selection screen. Refer to chapters **6.1 Selection modes** and **8.1 Selection of Auto Sequences®**.



Saves a measurement.
Saving of measurement under the selected Structure object.



View / edit parameters and attachments.
Parameters and attachments of the Structure object can be viewed or edited. Refer to chapter **5.1.5.3 View / Edit parameters and attachments of a Structure object** for more information.



Adds a new measurement.
The instrument goes to the Menu for adding measurement into structure. Refer to chapter **5.1.5.5 Add a new measurement** for more information.



Adds a new Structure object.
A new Structure object can be added. Refer to chapter **5.1.5.4 Add a new Structure Object** for more information.



Attachments.
Name and link of attachment is displayed.



Clones a Structure object.
Selected Structure object can be copied to same level in structure tree (clone). Refer to chapter **5.1.5.6 Clone a Structure object** for more information.



Copies & Paste a Structure object.
Selected Structure object can be copied and pasted to any allowed location in structure tree. Multiple "Paste" is allowed. Refer to chapter **5.1.5.8 Copy & Paste a Structure object** for more information.



Cut & Paste a Structure.
Selected Structure with child items (sub-structures and measurements) can be moved to any allowed location in structure tree. Refer to chapter **5.1.5.11 Cut & Paste a Structure object with sub-items** for more information.



Views and edit comments.

The instrument displays comment attached to the selected Structure object or opens keypad for entering a new comment.



Deletes a Structure object.
Selected Structure object and sub-elements can be deleted. User is asked for confirmation before the deleting. Refer to chapter **5.1.5.12 Delete a Structure object** for more information.







Renames a Structure object.
Selected Structure object can be renamed via keypad. Refer to chapter **5.1.5.14 Rename a Structure object** for more information.

5.1.5.3 View / Edit parameters and attachments of a Structure object

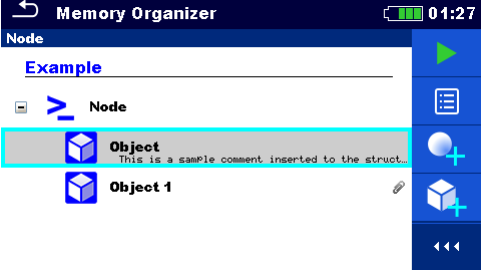
The parameters and their content are displayed in this menu. To edit the selected parameter, tap on it or press the  key to enter menu for editing parameters.

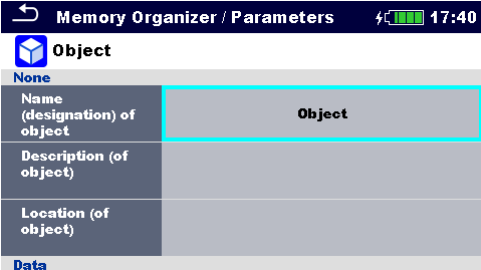
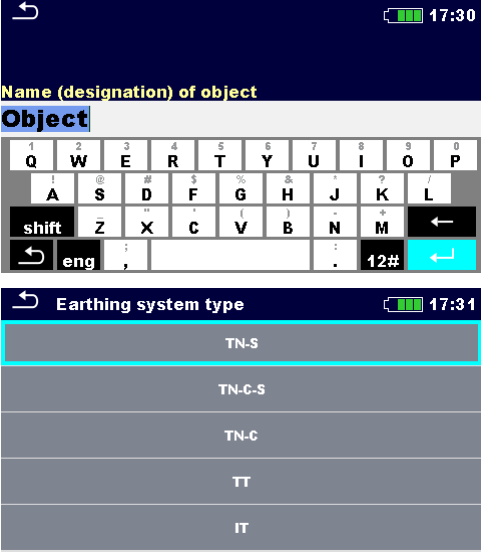
Procedure

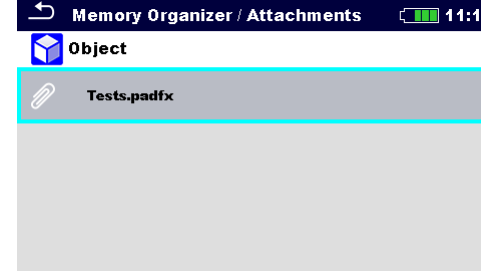
- | | | |
|----|---|--|
| ① |  | Select structure object to be edited. |
| ② |  | Select Parameters in Control panel. |
| ③ |  | Example of Parameters menu. |
| ④ |  | In menu for editing parameters the parameter's value can be selected from a dropdown list or entered via keypad. Refer to chapter 4 Instrument operation for more information about keypad operation. |
| ②a |  | Select Attachments in Control panel. |
| ③a |  | Attachments
The name of attachment can be seen.
Operation with attachments is not supported in the instrument. |



Select Comments in Control panel.



View or edit comments

Complete comment (if exists) attached to the structure object can be seen on this screen.







Press  key or tap on screen to open keypad for entering a new comment.

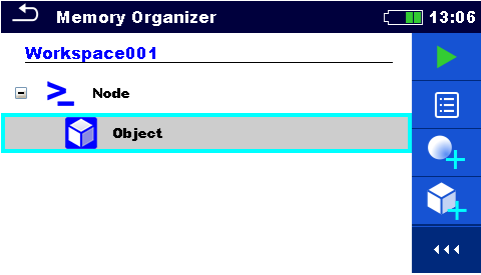

5.1.5.4 Add a new Structure Object

This menu is intended to add new structure objects in the tree menu. A new structure object can be selected and then added in the tree menu.

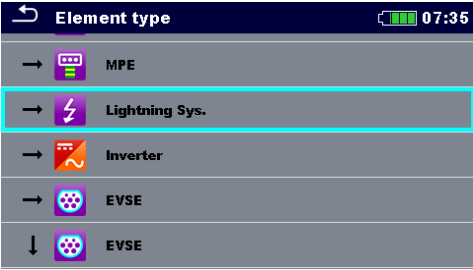
Procedure

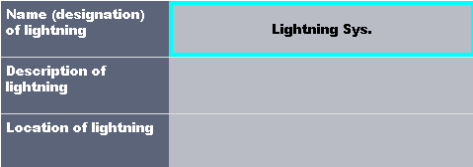

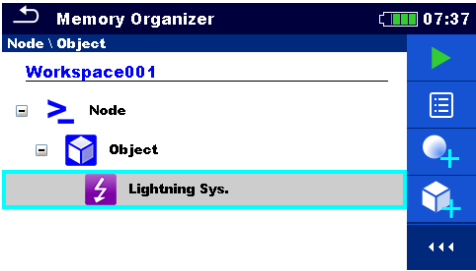



-
- ①  Default initial structure.
-
- ②  Select Add Structure in Control panel.
-
- ③  Add a new structure object menu.
-
- ③a  Tap on a structure type selection window.
-  A list of available structure items is displayed. Select one from a list. Arrow indicates the position where structure item will be inserted.
-  Child item to the currently selected structure item.
 -  Structure item located in the same level.
-
- ③b  The name of structure object can be edited.

④		Create new structure item.
⑤		New object added.

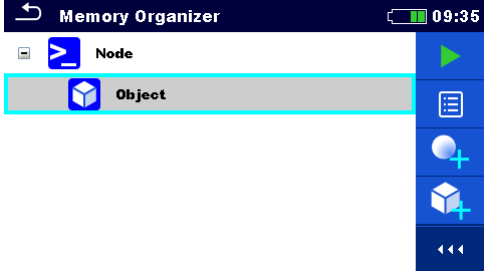
5.1.5.5 Add a new measurement

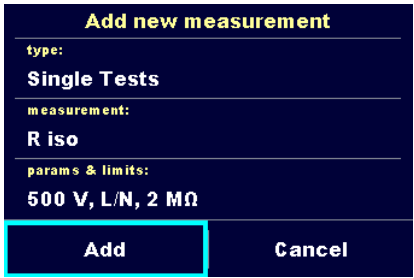
In this menu new empty measurements can be set and then added in the structure tree. The type of measurement, measurement function and its parameters are first selected and then added under the selected Structure object.

Procedure

①		Select level in structure where measurement will be added.
②		Select Add measurement in Control panel.
③		Add new measurement menu.
③a		Type of test can be selected from this field. Options: (Single Tests, Auto Sequences®)
③b		Tap on field or press the  key to modify.
		Last added measurement is offered by default.

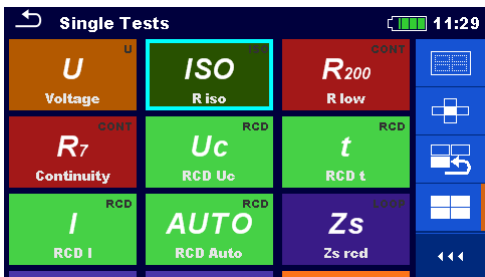

To select another measurement tap on filed press the  to open menu for selecting measurements.

③c

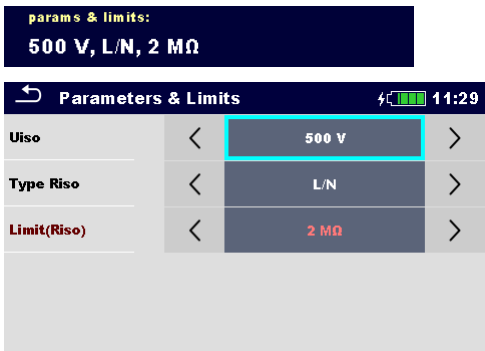

Select parameter and modify it as described earlier. Refer to chapter **6.1.2 Setting parameters, limits and comments of single tests** for more information.

④

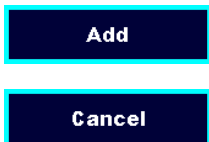

Adds the measurement under the selected Structure object in the tree menu. Returns to the structure tree menu without changes.

⑤

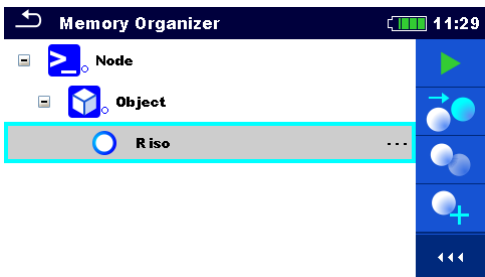



New empty measurement is added under the selected Structure object.

5.1.5.6 Clone a Structure object

In this menu selected structure object can be copied (cloned) to same level in the structure tree. Cloned structure object has the same name as the original.

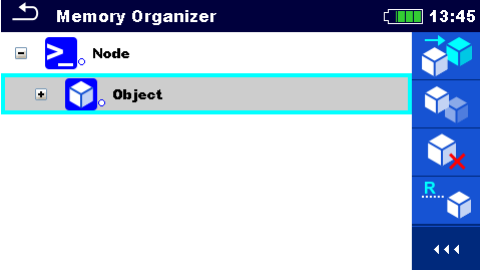

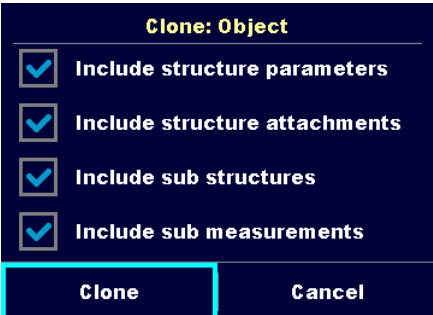
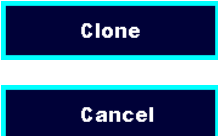
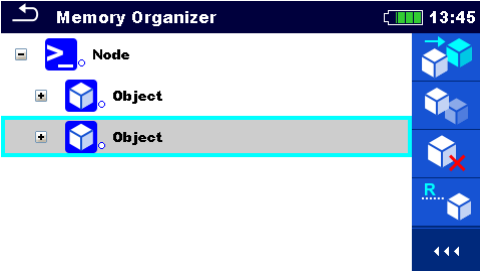
Procedure

①		Select the structure object to be cloned.
②		Select Clone in Control panel.
③		<p>The Clone Structure object menu is displayed. Sub-elements of the selected structure object can be marked or un-marked for cloning.</p> <p>Refer to chapter 5.1.5.9 Cloning and Pasting sub-elements of selected structure object for more information.</p>
④		<p>Selected structure object is copied (cloned) to same level in the structure tree.</p> <p>Cloning is cancelled. No changes in the Structure tree.</p>
⑤		The new structure object is displayed.

5.1.5.7 Clone a measurement

By using this function a selected empty or finished measurement can be copied (cloned) as an empty measurement to the same level in the structure tree. Parameters and limits of new measurement are the same as they are set in original measurement. Its parameters/limits can be changed when measurement is started.

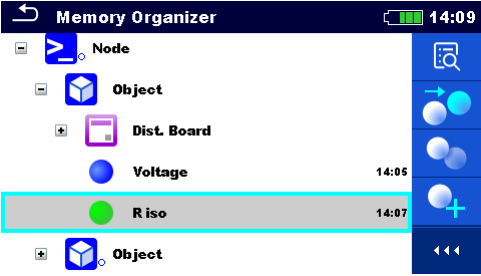

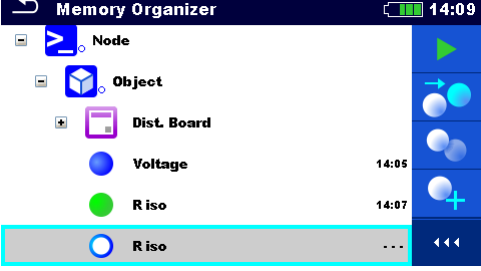
Procedure

①		Select the measurement to be cloned.
②		Select Clone in Control panel.
③		A new empty measurement is displayed.

5.1.5.8 Copy & Paste a Structure object

In this menu selected Structure object can be copied and pasted to any allowed location in the structure tree.

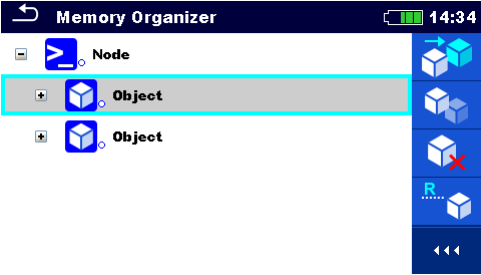
Procedure

①		Select the structure object to be copied.
②		Select Copy in control panel.

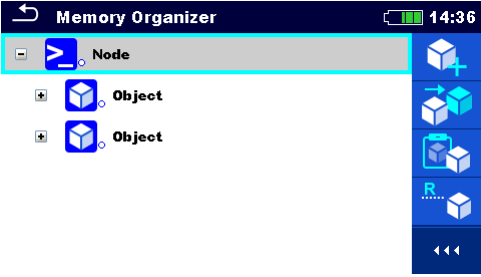
- ③ 

Select location where structure element should be copied.
- ④ 

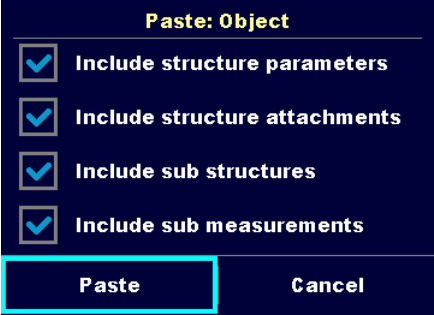
Select Paste in Control panel.
- ⑤ 

The Paste structure object menu is displayed.
Before copying it can be set which sub-elements of the selected structure object will be copied too. Refer to chapter **5.1.5.9 Cloning and Pasting sub-elements of selected structure object** for more information.
- ⑥ 

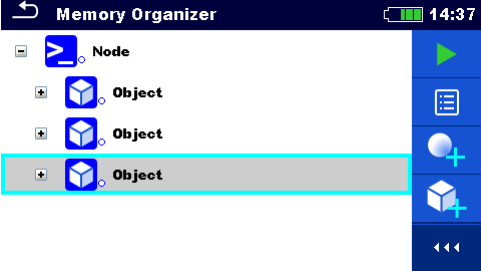

The selected structure object and elements are copied (pasted) to selected position in the tree structure.
Returns to the tree menu without changes.
- ⑦ 

The new structure object is displayed.

Note
The Paste command can be executed one or more times.

5.1.5.9 Cloning and Pasting sub-elements of selected structure object

When structure object is selected to be cloned, or copied & pasted, additional selection of its sub-elements is needed. The following options are available:

Options

- Include structure parameters**

Parameters of selected structure object will be cloned / pasted too.
- Include structure attachments**

Attachments of selected structure object will be cloned / pasted too.
- Include sub structures**

Structure objects in sub-levels of selected structure object will be cloned / pasted too.
- Include sub measurements**

Measurements in selected structure object and sub-levels will be cloned / pasted too.

5.1.5.10 Copy & Paste a measurement

In this menu selected measurement can be copied as an empty measurement to any allowed location in the structure tree. Selected measurement can be copied multiple times to different locations in the structure tree. Parameters and limits of new measurement are the same as they are set in original measurement. Its parameters/limits can be changed when measurement is started.

Procedure

①		Select the measurement to be copied.
②		Select Copy in Control panel.
③		Select the location where measurement should be pasted.
④		Select Paste in Control panel.
⑤		A new (empty) measurement is displayed in selected Structure object.





Note

The Paste command can be executed one or more times.

5.1.5.11 Cut & Paste a Structure object with sub-items

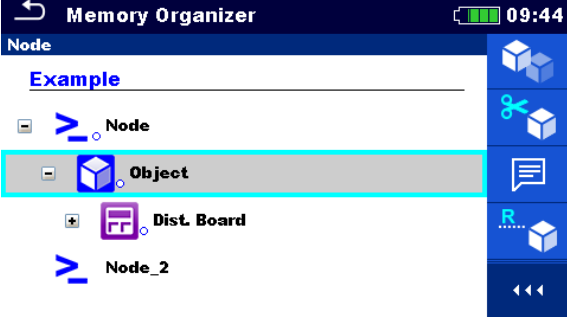
In this menu selected Structure object with sub-items (sub-structures and measurements) can be cut and pasted (moved) to any allowed location in the structure tree.

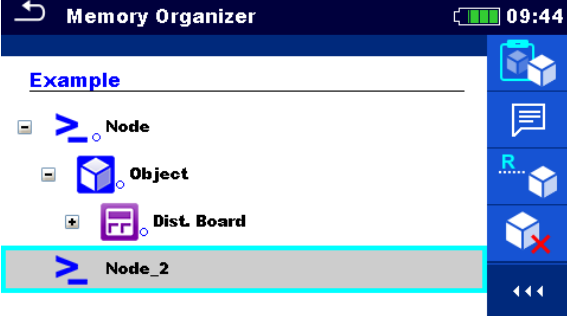
Procedure

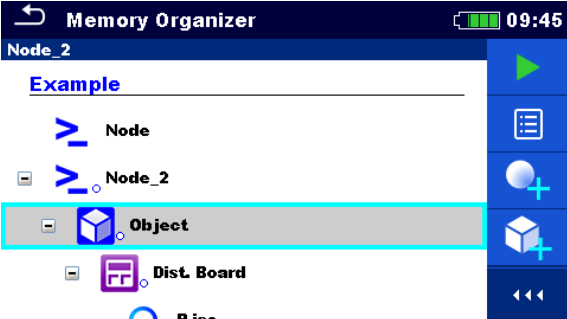
- | | | |
|---|--|---|
| ① |  <p>The screenshot shows the 'Memory Organizer' interface. The tree structure includes 'Node', 'Object', 'Dist. Board', and 'Node_2'. The 'Object' item is highlighted with a red border. The right-hand control panel is visible, showing various icons for actions like cut, paste, and search.</p> | Select the structure item to be moved. |
| ② |  <p>A close-up of the 'Cut' icon, which consists of a pair of scissors and a cube.</p> | Select Cut option from Control panel. |
| ③ |  <p>The screenshot shows the same tree structure as in step 1, but now 'Node_2' is highlighted with a red border. The 'Cut' icon in the control panel is highlighted with a red box.</p> | Select new location where structure object (with sub-structures and measurements) should be moved. |
| ④ |  <p>A close-up of the 'Paste' icon, which consists of a cube with a plus sign.</p> | Select Paste option from Control panel. |
| ⑤ |  <p>The screenshot shows the tree structure after the move. 'Node_2' is now the selected item, and 'Object' is now listed as a sub-item under 'Node_2'. The 'Paste' icon in the control panel is highlighted with a red box.</p> | The structure object (with sub-structures and measurements) is moved to selected new location and deleted from previous location in the tree structure. |

5.1.5.12 Delete a Structure object

In this menu selected Structure object can be deleted.

Procedure

	<p>Select the structure object to be deleted.</p>
	<p>Select Delete in Control panel.</p>
	<p>A confirmation window will appear.</p>
	<p>Structure without deleted object.</p>

5.1.5.13 Delete a measurement

In this menu selected measurement can be deleted from selected location in the tree structure.

Procedure

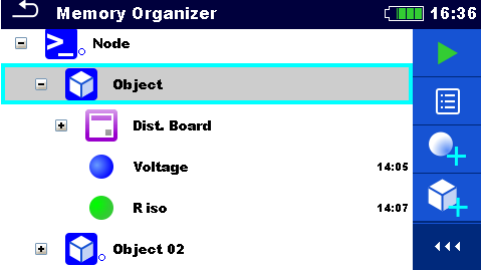

	<p>Select a measurement to be deleted.</p>
	<p>Select Delete in Control panel.</p>

③		<p>A confirmation window will appear.</p>
		<p>Selected measurement is deleted.</p>
		<p>Returns to the tree menu without changes.</p>
④		<p>Structure without deleted measurement.</p>

5.1.5.14 Rename a Structure object



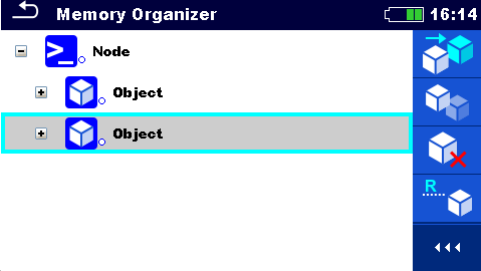

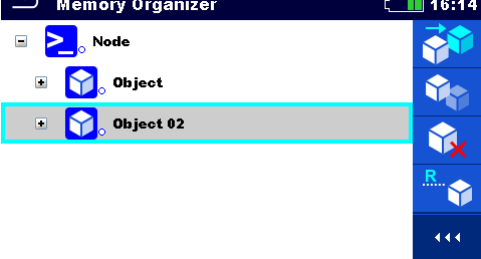

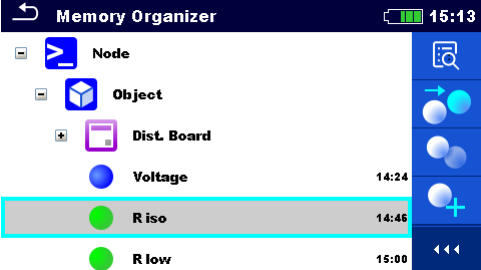

In this menu selected Structure object can be renamed.

Procedure

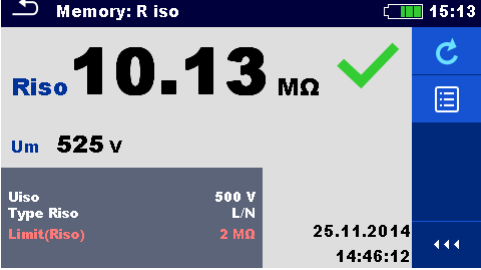
①		<p>Select the structure object to be renamed.</p>
②		<p>Select Rename in Control panel.</p>
③		<p>Virtual keypad will appear on screen. Enter new text and confirm. Refer to chapter 4.3 Virtual keyboard for keypad operation.</p>
④		<p>Structure object with the modified name.</p>

5.1.5.15 Recall and Retest selected measurement

Procedure

- | | | |
|----|---|---|
| ① |  | Select the measurement to be recalled. |
| ② |  | Select Recall results in Control panel. |
| ③ |  | Measurement is recalled. |
| ③a |  | Parameters and limits can be viewed but cannot be edited. |
| ④ |  | Select Retest in Control panel. |
| ⑤ |  | Measurement retest starting screen is displayed. |
| ⑤a |  | Parameters and limits can be viewed and edited. |
| ⑥ |  | Select Run in Control panel to retest the measurement. |

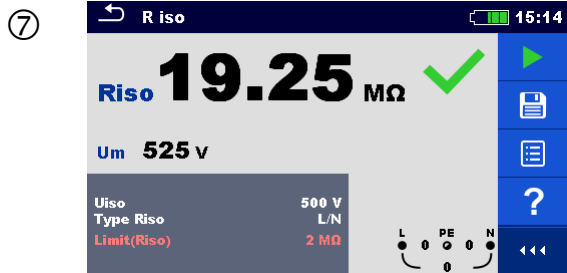

Results / sub-results after re-run of recalled measurement.

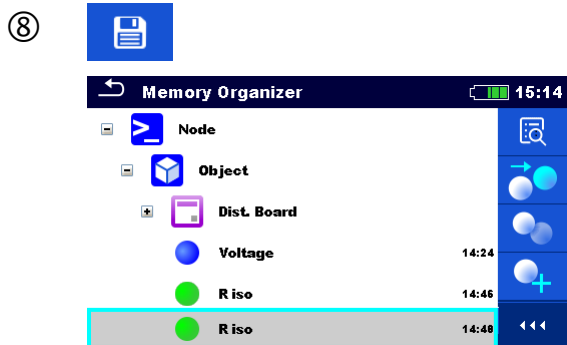

Select Save results in Control panel.

Retested measurement is saved under same structure object as original one. Refreshed memory structure with the new performed measurement.

5.1.6 Searching in Memory Organizer

In Memory organizer it is possible to search for different structure objects and parameters. Search function is available from the active workspace directory line as presented on **Figure 5.6**.

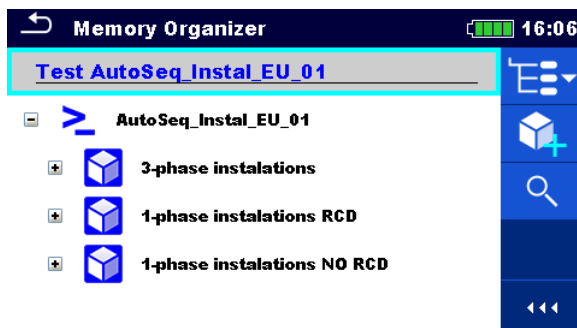
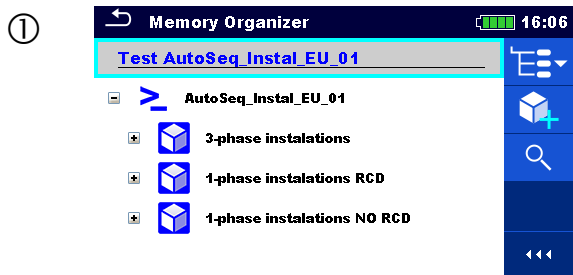

Figure 5.6: Active workspace directory with expanded menu

Procedure



Search function is available from the active workspace directory line.

Use external device for data entry or follow instructions below for instrument search function.



Select Search in control panel to open Search setup menu.

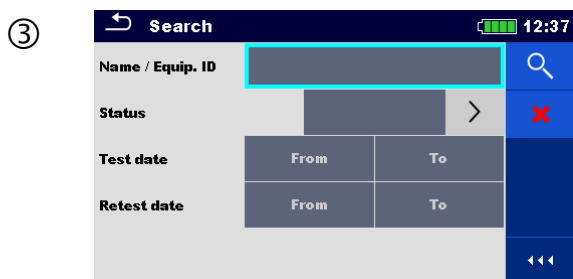

The parameter that can be searched for is displayed in the search setup menu.

Note:

- Equipment ID, Test date and Retest date (if applicable) refer only to the following structure objects: Machine, EVSE and Appliance.



The search can be narrowed by entering a text in the Name / Equip. ID field.

Strings can be entered using the on-screen keyboard.

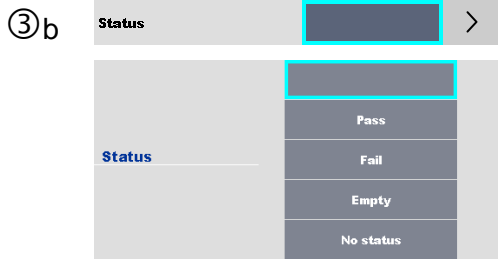

The search can be narrowed on base of statuses.

If searching by status, instrument will display all structure objects that include one or more measurements with searched status.

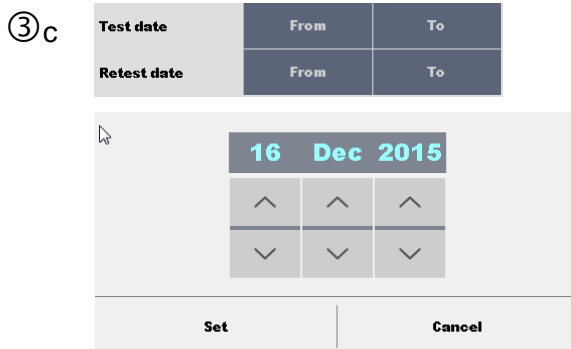

The search can be narrowed on base of test dates / retest dates (from / to).



Clears all filters.



Searches through the Memory Organizer for objects according to the set filter. The results are shown in the Search results screen presented on **Figure 5.7**.

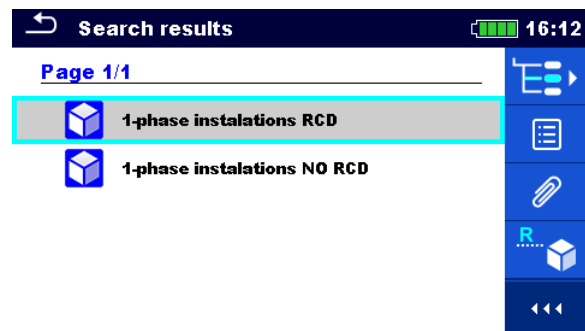
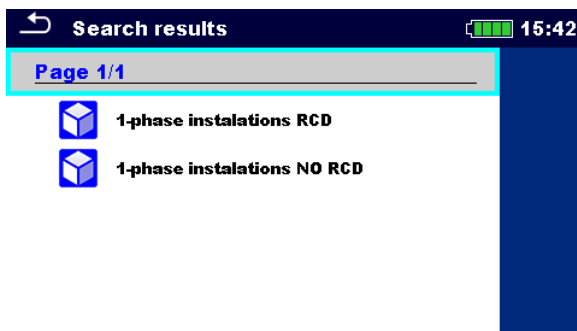

Figure 5.7: Search results screen (left), structure object selected (right)

Options



Next page (if available).



Previous page (if available).



Goes to location in Memory Organizer.



View / edit parameters and attachments.

Parameters and attachments of the Structure object can be viewed or edited. Refer to chapter **5.1.5.3 View / Edit parameters and attachments of a Structure object** for more information.



Attachments.

Name and link of attachment is displayed.



Views comment.

The instrument displays comment attached to the selected Structure object.



Renames the selected Structure object.

Refer to chapter **5.1.5.14 Rename a Structure object** for more information.

Note:

- › Search result page consist of up to 50 results.

6 Single tests

Single tests can be selected in the main **Single tests** menu or in **Memory organizer** main menu and sub-menus.

6.1 Selection modes

In **Single test main menu** four modes for selecting single tests are available.

Options



Area Group

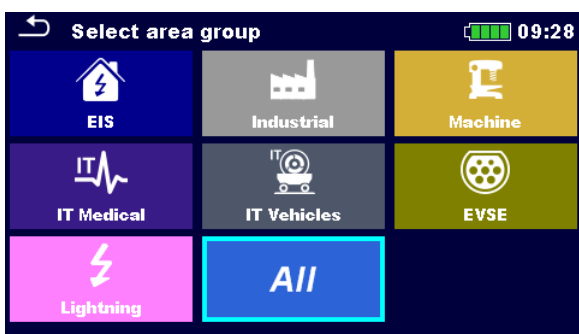

With help of area groups it is possible to limit the offered single tests. The instrument has several area groups:

- ▶ the EIS group,
- ▶ the Industrial group,
- ▶ the Machine group,
- ▶ the IT Medical group,
- ▶ the IT Vehicles group,
- ▶ the EVSE group,
- ▶ the Lightning group.

In the All group all measurements are offered.



Groups

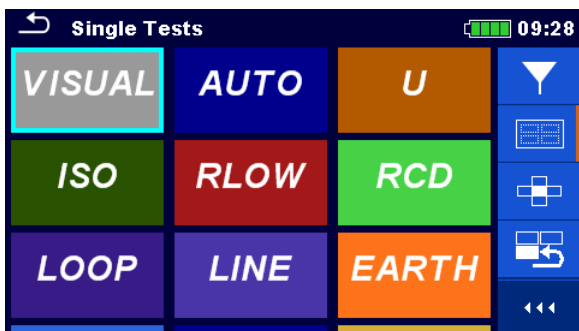

The single tests are divided into groups of similar tests.

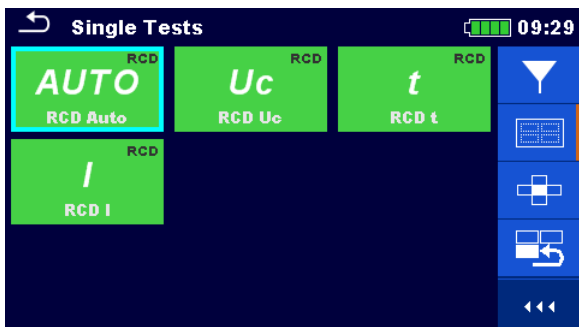

For the selected group a submenu with all single tests that belongs to the selected group is displayed.



Cross selector

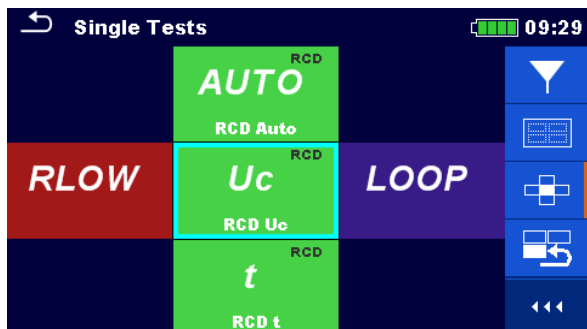

This selection mode is the fastest for working with the keypad.

Groups of single tests are organized in a row.

For the selected group all single tests are displayed and easy accessible with up/down keys.



Last used

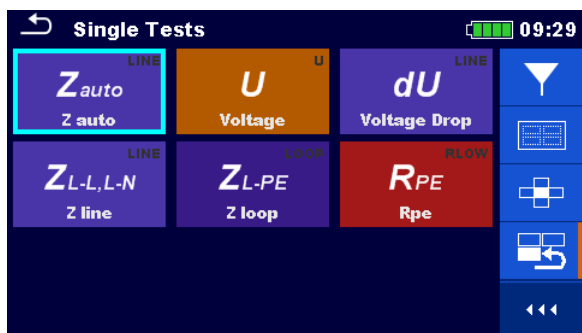

Last 9 made different single tests are displayed.



Expands control panel / open more options.

6.1.1 Single test (measurement) screens

In the Single test (measurement) screens measuring results, sub-results, limits and parameters of the measurement are displayed. In addition on-line statuses, warnings and other info are displayed.



Figure 6.1: Single test screen organization, example of insulation resistance measurement

Single test screen organization

	<p>Header line:</p> <ul style="list-style-type: none"> › ESC touch key › function name › battery status › real time clock
	<p>Control panel (available options)</p>
	<p>Parameters (white) and limits (red)</p>
	<p>Result field:</p> <ul style="list-style-type: none"> › main result(s) › sub-result(s) › PASS / FAIL indication
	<p>Voltage monitor with info and warning symbols</p>

6.1.2 Setting parameters, limits and comments of single tests

Procedure

- | | | |
|----|--|---|
| ① | | <p>Select the test or measurement.
The test can be entered from:</p> <ul style="list-style-type: none"> Single tests menu or Memory organizer menu once the empty measurement was created in selected object structure. |
| ② | | <p>Select Parameters in Control panel.
Opens parameters and limits setting menu.</p> |
| ③ | | <p>Parameters and Limits menu.
Some single tests support user comment entry.</p> |
| ③a | | <p>Modify parameter or limit value with touchscreen or keyboard buttons.</p> |
| ③b | | <p>Select parameter to be edited or limit / comment to be set.</p> |
| ③c | | <p>Opens parameter or limit selection list or on-screen keyboard for entering comment.</p> |
| ④a | | <p>Select parameter or limit value from the list.
Note:</p> <ul style="list-style-type: none"> Touchscreen or keyboard selection methods can be used |

interchangeably; confirm keyboard selection with .

④ b



on

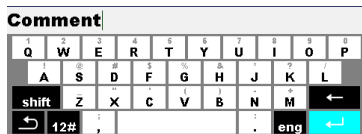

Enter comment and confirm with .

⑤



Accepts and set selected parameters, selected limit values and user comments and exits Single Test setting.

Note:

- Set parameters, set limits and entered user comments are saved to the memory. When same Single test is used next time, settings and comments will remain the same.

6.1.3 Single test start screen

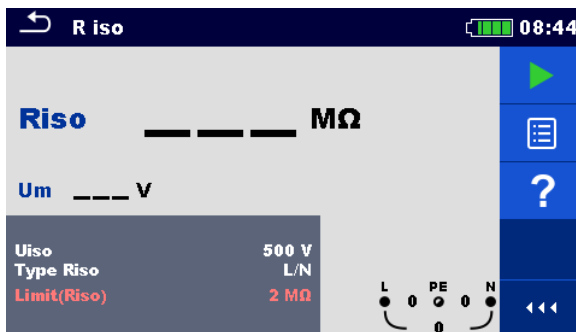

Figure 6.2: Single test start screen, example of insulation resistance measurement

Options (before test, screen was opened in Memory organizer or Single test main menu):



Starts the measurement.



long

Starts the continuous measurement (if applicable on selected single test).



long



Opens help screens.



Opens menu for changing parameters and limits. Refer to chapter **6.1.2 Setting parameters, limits and comments** of single tests for more information.



on





Enters cross selector to select test or measurement.



Expands column in control panel.



6.1.4 Single test screen during test

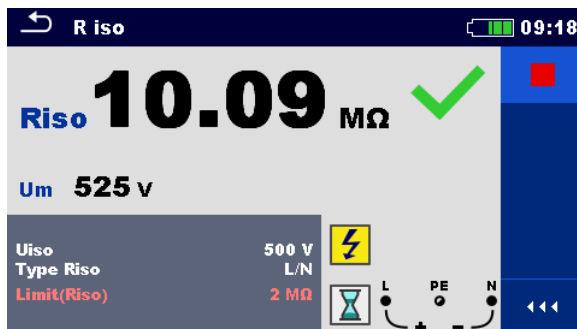

Figure 6.3: Single test is running, example of insulation resistance continuous measurement

Operations (when test is running):



Stops the single test measurement.



Proceeds to next step of the measurement (if measurement consists of more steps).



Previous value.



Next value.



Stops or aborts the measurement and returns one menu back.

6.1.5 Single test result screen

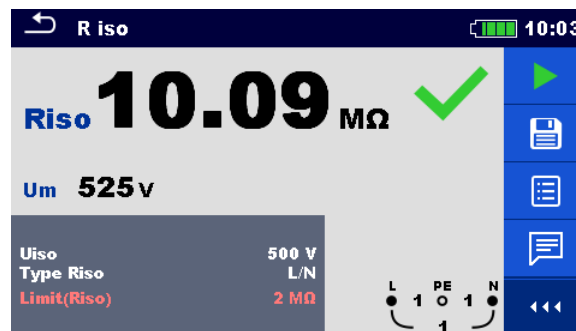









Figure 6.4: Single test results screen, example of insulation resistance measurement results

Options (after measurement is finished):

	Starts a new measurement.
	
 long	Starts a new continuous measurement (if applicable on selected single test).
 long	
	Saves the result.
	<p>A new measurement was selected and started from a Structure object in the structure tree:</p> <ul style="list-style-type: none"> the measurement will be saved under the selected Structure object. <p>A new measurement was started from the Single test main menu:</p> <ul style="list-style-type: none"> saving under the last selected Structure object will be offered by default. The user can select another Structure object or create a new Structure object. By pressing the  key in Memory organizer menu the measurement is saved under selected location. <p>An empty measurement was selected in structure tree and started:</p> <ul style="list-style-type: none"> the result(s) will be added to the measurement. The measurement will change its status from 'empty' to 'finished'. <p>An already carried out measurement was selected in structure tree, viewed and then restarted:</p> <ul style="list-style-type: none"> a new measurement will be saved under the selected Structure object.

	<p>Opens screen for changing parameters and limits. Refer to chapter 6.1.2 Setting parameters, limits and comments of single tests for more information.</p>
	<p>Adds comment to the measurement. The instrument opens keypad for entering a comment.</p>
	<p>Opens help screens.</p>
	<p>Enters cross selector to select test or measurement.</p>
	<p>Expands column in control panel.</p>

6.1.6 Editing graphs (Harmonics)

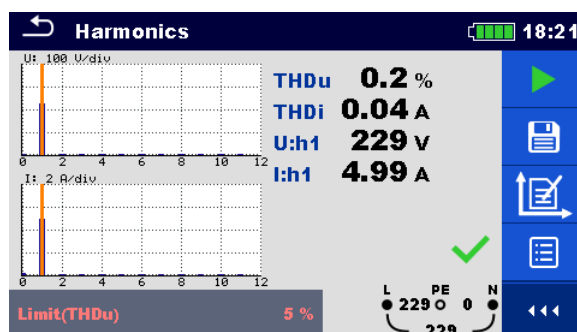

Figure 6.5: Example of Harmonics measurement results

Options for editing graphs (start screen or after measurement is finished)

	<p>Plot edit Opens control panel for editing graphs.</p>
	<p>Increase scale factor for y-axis.</p>
	<p>Decrease scale factor for y-axis.</p>
	<p>Toggle between U and I graph to set scale factor</p>
	<p>Exits from editing graphs.</p>



6.1.7 Single test (inspection) screens

Visual and Functional inspections can be treated as a special class of tests. Items to be visually or functionally checked are displayed. In addition on-line statuses and other information are displayed. Type of inspection depends on type and profile of the instruments.

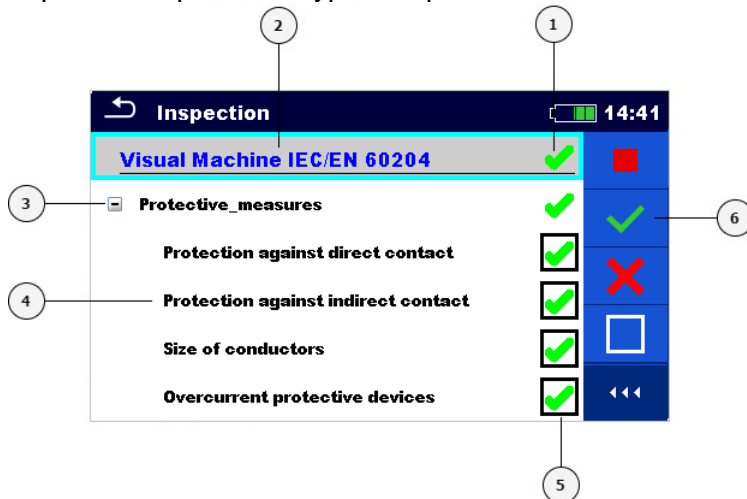

Figure 6.6: Inspection screen organisation

Legend

- 1 Overall status of the inspection
- 2 Selected inspection
- 3 Item
- 4 Child items
- 5 Status fields (for items and child items)
- 6 Control panel (available options)

6.1.7.1 Single test (inspection) start screen

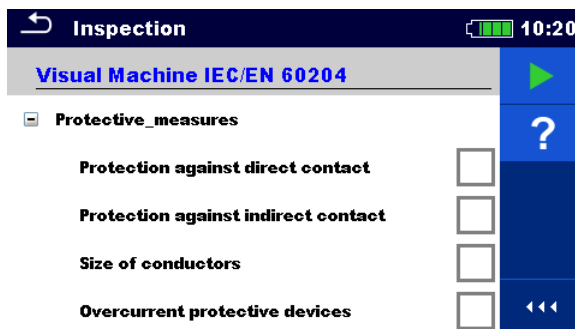

Figure 6.7: Inspection start screen

Options (inspection screen was opened in Memory organizer or from Single test main menu)

-  Starts the inspection.

-  Opens help screens.
Refer to chapter **6.1.8 Help screens** for more information.

6.1.7.2 Single test (Inspection) screen during test

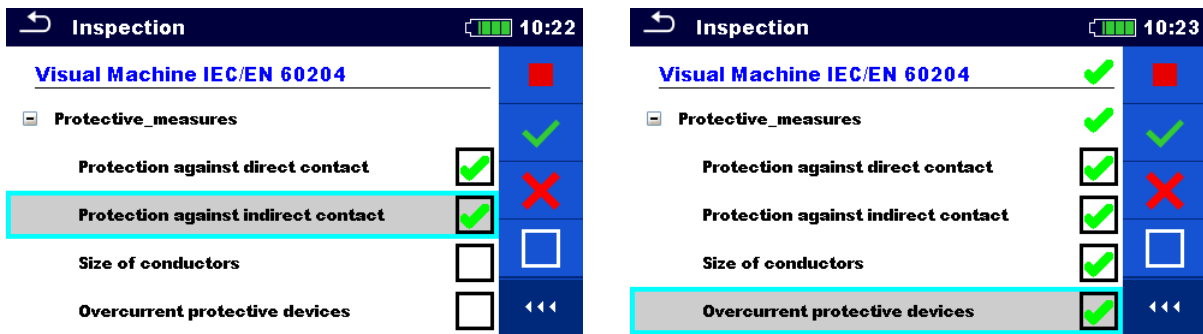







Figure 6.8: Inspection screen (during inspection)

Options (during test)

-  Selects item.
- 
- 

-  Stops the inspection.

-  Applies a pass to the selected item or group of items.

-  Applies a fail to the selected item or group of items.

-  Clears status in selected item or group of items

-  Applies checked status to selected item or group of items.

-  A status can be applied
Multiple taps toggles between statuses.

-  Toggle between statuses.

-  Goes to the result screen.

Rules for automatic applying of statuses:





- › The parent item(s) can automatically get a status on base of statuses in child items.
 - › the fail status has highest priority. A fail status for any item will result in a fail status in all parent items and an overall fail result.

- › if there is no fail status in child items the parent item will get a status only if all child items have a status.
- › Pass status has priority over checked status.
- › The child item(s) will automatically get a status on base of status in the parent item.
- › All child items will get the same status as applied to the parent item.

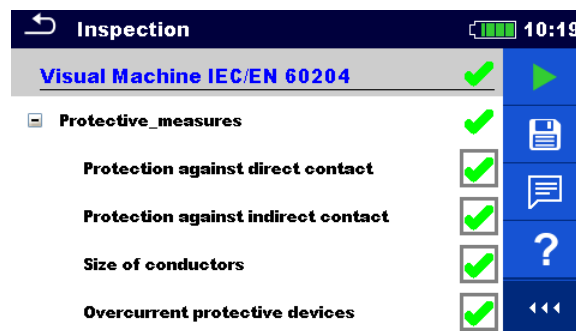
Notes:

- › Inspections and even inspection items inside one inspection can have different status types. For example, some basic inspections don't have the 'checked' status.
- › Only inspections with overall statuses can be saved.

6.1.7.3 Single test (Inspection) result screen**Figure 6.9: Inspection result screen****Options (after inspection is finished)**

	Starts a new inspection.
	<p>Saves the result.</p> <p>A new inspection was selected and started from a Structure object in the structure tree:</p> <ul style="list-style-type: none"> › The inspection will be saved under the selected Structure object. <p>A new inspection was started from the Single test main menu:</p> <ul style="list-style-type: none"> › Saving under the last selected Structure object will be offered by default. The user can select another Structure object or create a new Structure object. By pressing the  key in Memory organizer menu the inspection is saved under selected location. <p>An empty inspection was selected in structure tree and started:</p> <ul style="list-style-type: none"> › The result(s) will be added to the inspection. The inspection will change its status from 'empty' to 'finished'. <p>An already carried out inspection was selected in structure tree, viewed and then restarted:</p> <ul style="list-style-type: none"> › A new measurement will be saved under the selected Structure object.
	Adds comment to the finished inspection. The instrument opens keypad for entering a comment.
	Opens help screens. Refer to chapter 6.1.8 Help screens for more information.

6.1.7.4 Single test (inspection) memory screen

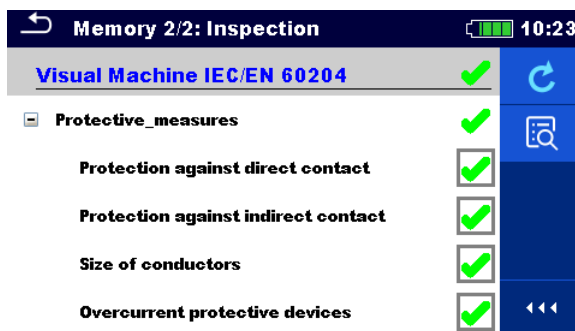



Figure 6.10: Inspection memory screen

Options

 **Retest**
Enters screen with 'empty' measurement.

 Enters view mode.

6.1.8 Help screens

Help screens contain diagrams for proper connection of the instrument.

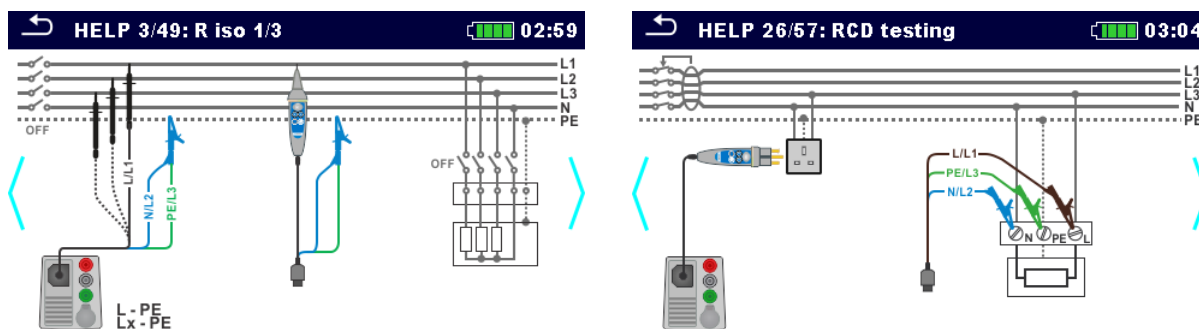



Figure 6.11: Examples of help screens

Options

 Opens help screen.

 Goes to previous / next help screen.





Back to test / measurement menu.



6.1.9 Recall single test results screen

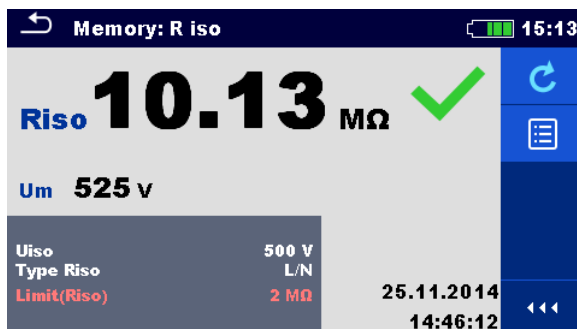

Figure 6.12: Recalled results of selected measurement, example of insulation resistance recalled results

Options



Retest
 Enters starting screen for a new measurement.
 Refer to chapter **6.1.3 Single test start screen** for more information.



Opens menu for viewing parameters and limits.
 Refer to chapter **6.1.2 Setting parameters, limits and comments** of single tests for more information.



on



Expands column in control panel.



7 Tests and measurements

See chapter **6.1 Selection modes** for instructions on keys and touch screen functionality.

7.1 Voltage, frequency and phase sequence

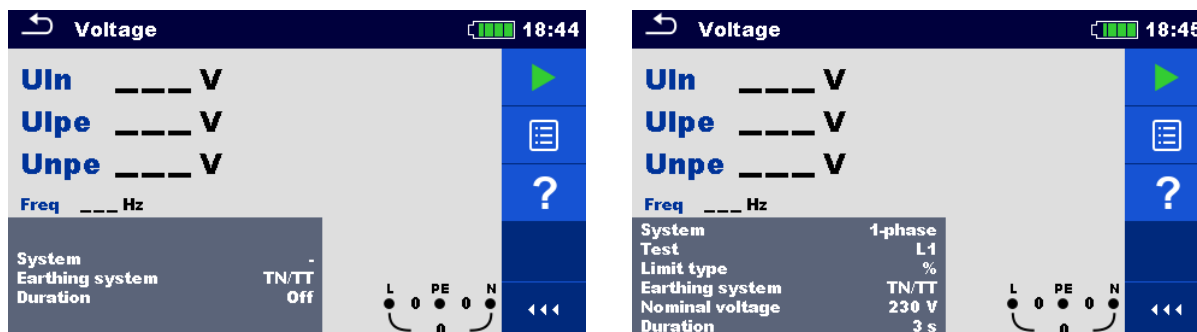

Figure 7.1: Voltage measurement menu

Measurement parameters

System¹⁾	Voltage system [-, 1-phase,3-phase]
Test³⁾	Phase to be tested [-, L1, L2, L3]
Limit type	Type of limit [Voltage, %]
Earthing system	Earthing system [TN/TT, IT]
Nominal voltage²⁾	Nominal voltage [Custom, 110V, 115V, 190V, 200V, 220V, 230V, 240V, 380V, 400V, 415V]
Reference field⁴⁾	Correct phase rotation [-, 1.2.3, 3.2.1]
Duration	Test duration [Off, Custom, 1 s, 3 s, 5 s]

¹⁾ There are no limits to set if System parameter is set to [-].

²⁾ Active only if limit type parameter is set to %.

³⁾ Active only when System is set to 1-phase.

⁴⁾ Active only when System is set to 3-phase; set parameter (1.2.3 or 3.2.1) to verify correct phase sequence during Voltage test.

Refer to chapter **4.6.8 Settings** for more information.

Measurement limits for TN/TT earthing system:

Low limit Uln⁵⁾	Min. voltage [Off, Custom, 0 V ... 499 V]
High limit Uln⁵⁾	Max. voltage [Off, Custom, 0 V ... 499 V]
Low limit Uln⁶⁾	Min. voltage [Off, Custom, -20% ... 20%]
High limit Uln⁶⁾	Max. voltage [Off, Custom, -20% ... 20%]
Low limit Ulpe^{5,6)}	Min. voltage [Off, Custom, 0 V ... 499 V]
High limit Ulpe^{5,6)}	Max. voltage [Off, Custom, 0 V ... 499 V]
Low limit Unpe^{5,6)}	Min. voltage [Off, Custom, 0 V ... 499 V]
High limit Unpe^{5,6)}	Max. voltage [Off, Custom, 0 V ... 499 V]
Low limit U12⁷⁾	Min. voltage [Off, Custom, 0 V ... 499 V]
High limit U12⁷⁾	Max. voltage [Off, Custom, 0 V ... 499 V]
Low limit U13⁷⁾	Min. voltage [Off, Custom, 0 V ... 499 V]
High limit U13⁷⁾	Max. voltage [Off, Custom, 0 V ... 499 V]
Low limit U23⁷⁾	Min. voltage [Off, Custom, 0 V ... 499 V]
High limit U23⁷⁾	Max. voltage [Off, Custom, 0 V ... 499 V]
Low limit UII⁸⁾	Min. voltage [Off, Custom, -20% ... 20%]
High limit UII⁸⁾	Max. voltage [Off, Custom, -20% ... 20%]

- 5) In case of 1-phase voltage system and limit type set to voltage.
- 6) In case of 1-phase voltage system and limit type set to %.
- 7) In case of 3-phase voltage system and limit type set to voltage.
- 8) In case of 3-phase voltage system and limit type set to %.

Measurement limits for IT earthing system:

Low limit U12^{9,11)}	Min. voltage [Off, Custom, 0 V ... 499 V]
High limit U12^{9,11)}	Max. voltage [Off, Custom, 0 V ... 499 V]
Low limit U12¹⁰⁾	Min. voltage [Off, Custom, -20% ... 20%]
High limit U12¹⁰⁾	Max. voltage [Off, Custom, -20% ... 20%]
Low limit U1pe^{9,10)}	Min. voltage [Off, Custom, 0 V ... 499 V]
High limit U1pe^{9,10)}	Max. voltage [Off, Custom, 0 V ... 499 V]
Low limit U2pe^{9,10)}	Min. voltage [Off, Custom, 0 V ... 499 V]
High limit U2pe^{9,10)}	Max. voltage [Off, Custom, 0 V ... 499 V]
Low limit U13¹¹⁾	Min. voltage [Off, Custom, 0 V ... 499 V]
High limit U13¹¹⁾	Max. voltage [Off, Custom, 0 V ... 499 V]
Low limit U23¹¹⁾	Min. voltage [Off, Custom, 0 V ... 499 V]
High limit U23¹¹⁾	Max. voltage [Off, Custom, 0 V ... 499 V]
Low limit UII¹²⁾	Min. voltage [Off, Custom, -20% ... 20%]
High limit UII¹²⁾	Max. voltage [Off, Custom, -20% ... 20%]

- 9) In case of 1-phase voltage system and limit type set to voltage.
- 10) In case of 1-phase voltage system and limit type set to %.
- 11) In case of 3-phase voltage system and limit type set to voltage.
- 12) In case of 3-phase voltage system and limit type set to %.

Connection diagrams

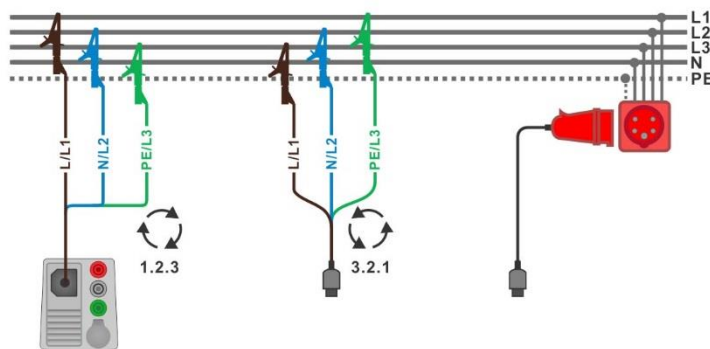

Figure 7.2: Connection of 3-wire test lead and optional adapter in three-phase system

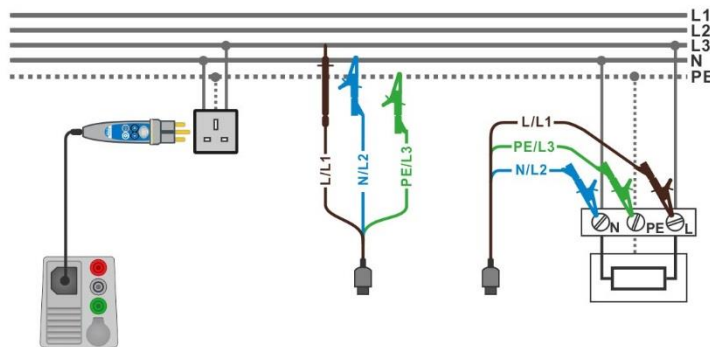

Figure 7.3: Connection of Plug commander and 3-wire test lead in single-phase system

Measurement procedure

- › Enter the **Voltage** function.
- › Set test parameters / limits.
- › Connect test cable to the instrument.
- › Connect test leads to object under test (see **Figure 7.2** and **Figure 7.3**).
- › Start the continuous measurement.
- › Stop the measurement, if Duration is set to Off.
- › Save results (optional).

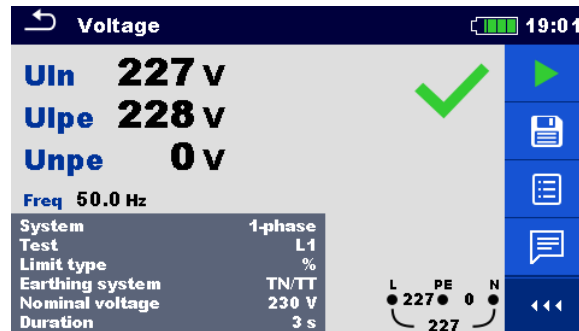

Figure 7.4: Example of Voltage measurement results in single-phase system

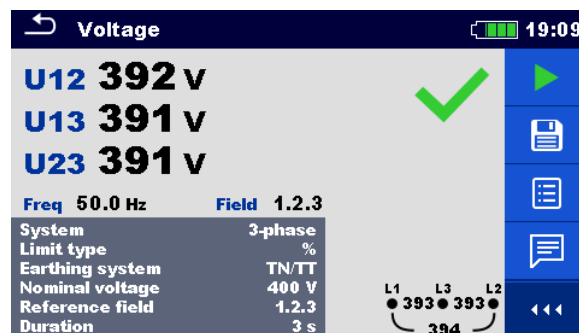

Figure 7.5: Example of Voltage measurement results in three-phase system

Measurement results / sub-results

Single-phase TN/TT system:

Uln	Voltage between phase and neutral conductors
Ulpe	Voltage between phase and protective conductors
Unpe	Voltage between neutral and protective conductors
Freq	Frequency

Single-phase IT system:

U12	Voltage between phases L1 and L2
U1pe	Voltage between phase L1 and PE
U2pe	Voltage between phase L2 and PE
Freq	Frequency

Three-phase TN/TT and IT system:

U12	Voltage between phases L1 and L2
------------	----------------------------------

U13	Voltage between phases L1 and L3
U23	Voltage between phases L2 and L3
Freq	Frequency
Field¹³⁾	3-phase rotation sequence

¹³⁾ For Pass test result, Field result must be equal to setting of Reference field parameter (1.2.3 or 3.2.1).

7.2 R iso – Insulation resistance

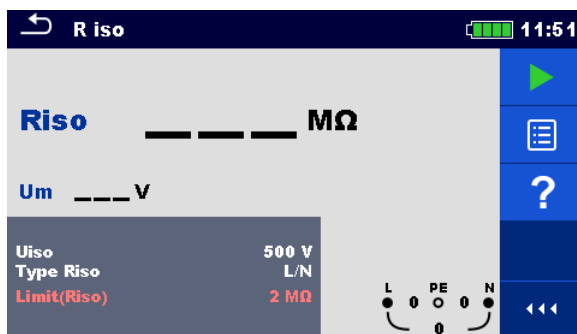

Figure 7.6: Insulation resistance measurement menu

Measurement parameters / limits

Uiso	Nominal test voltage [50 V, 100 V, 250 V, 500 V, 1000 V, 2500 V]
Type Riso¹⁾	Type of test [-, L/PE, L/N, N/PE, L/L, L1/L2, L1/L3, L2/L3, L1/N, L2/N, L3/N, L1/PE, L2/PE, L3/PE]
Limit(Riso)	Min. insulation resistance [Off, Custom, 0.01 MΩ ... 100 MΩ]

¹⁾ Insulation measurement depends on Type Riso parameter setting, see table below.

Type Riso parameter	3-wire test lead and Tip commander measuring terminals (U _N ≤ 1 kV)	2.5 kV test lead measuring terminals (U _N = 2.5 kV)
-		
L-N		
Lx-N	L and N	
L/L		
Lx-Ly		HV+ and HV-
L-PE		
Lx-PE	L and PE	
N-PE	N and PE	

Table 7.1: Insulation resistance measuring terminals and Type Riso parameter dependency

Connection diagrams

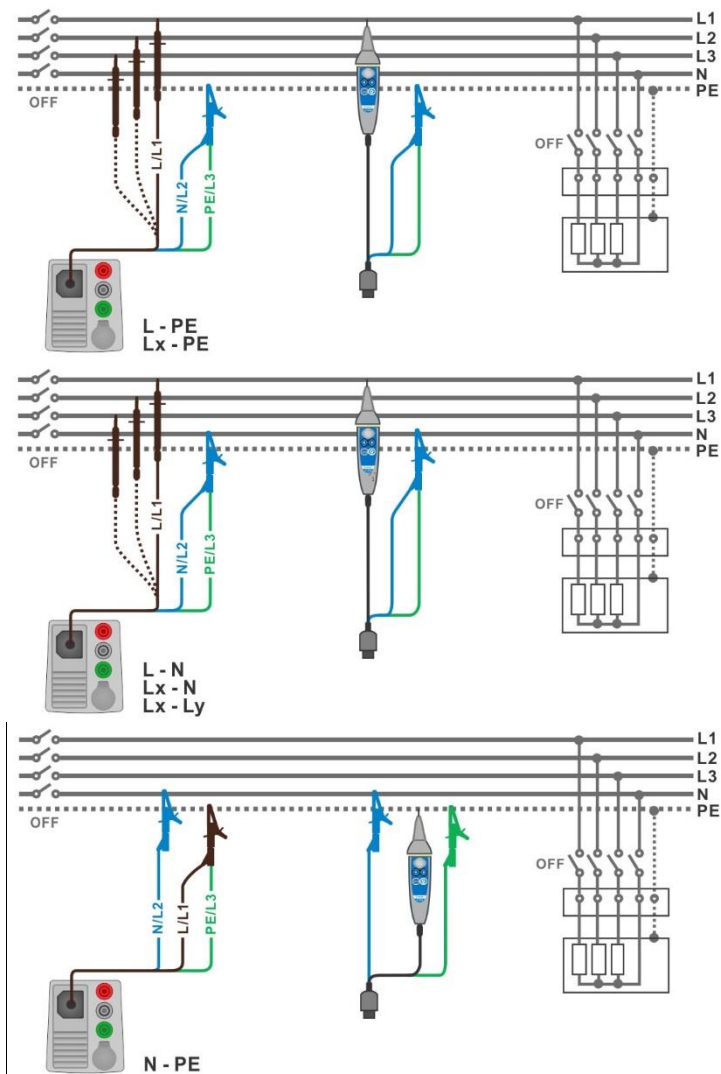

Figure 7.7: Connections of 3-wire test lead and Tip commander ($U_N \leq 1$ kV)

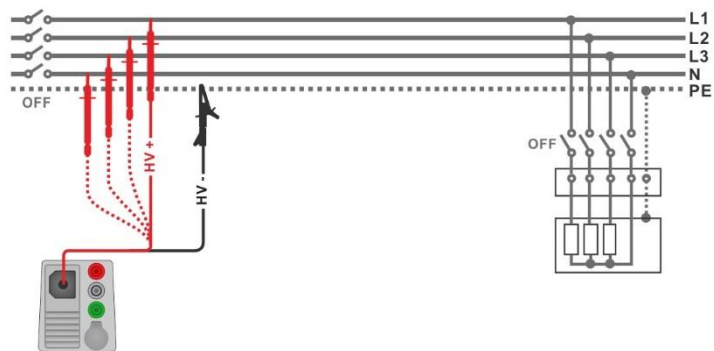

Figure 7.8: Connection of 2.5 kV test lead ($U_N = 2.5$ kV)

Measurement procedure

- › Enter the **R iso** function.
- › Set test parameters / limits.
- › Disconnect tested installation from mains supply and discharge installation as required.
- › Connect test cable to the instrument.

- Connect test leads to object under test (see **Figure 7.7** and **Figure 7.8**). Different test cable must be used for testing with nominal test voltage $U_N \leq 1000$ V and $U_N = 2500$ V. Also different test terminals are used. The standard 3-wire test lead, Plug test cable or Tip commander can be used for the insulation test with nominal test voltages ≤ 1000 V. For the 2500 V insulation test the two-wire 2.5 kV test lead should be used.

- Start the measurement. A longer press on  key or a longer press on 'Start test' option on touch screen starts a continuous measurement.
- Stop the measurement. Wait until object under test is fully discharged.
- Save results (optional).



Figure 7.9: Examples of Insulation resistance measurement result

Measurement results / sub-results

Riso	Insulation resistance
Uiso	Actual test voltage

7.2.1 Load pretest

High Insulation voltage can potentially damage the connected appliances during the Insulation measurement. This misuse can be prevented by enabling Load pretest functionality in Settings menu. Load pretest measures the impedance on test terminals with low and safe a.c. voltage. If impedance lower than 50 kΩ is detected, warning message is displayed, allowing to disconnect the appliances before test voltage is applied (see **Figure 7.10**). Insulation measuring voltage is applied to the test terminals only after YES is selected. NO will abort the measurement. If impedance higher than 50 kΩ is measured during the Load pretest, Insulation test will follow automatically.

Test function	Type Riso parameter	Load pretest terminals	
		3-wire test lead and Tip commander measuring terminals ($U_N \leq 1$ kV)	2.5 kV test lead measuring terminals ($U_N = 2.5$ kV)
Riso	-		
	L/N		
	Lx/N	L-N	x
	L/L		
	Lx/Ly		
	L/PE	L-PE	x
	Lx/PE		
	N/PE	N-PE	x

Riso - all	L-N, L-PE, N-PE	x
------------	-----------------	---

x.not applicable

Table 7.2: Insulation resistance measuring terminals and Load pretest dependency

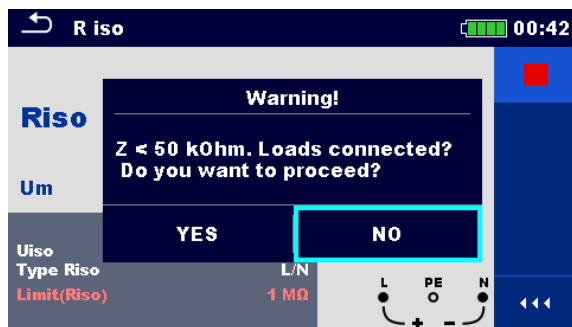

Figure 7.10: Load pretest warning message

7.3 R iso all – Insulation resistance

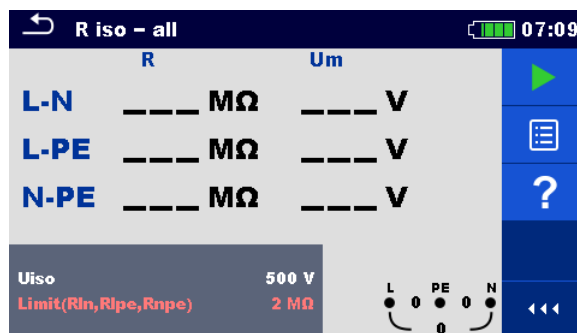

Figure 7.11: R iso - all measurement menu

Measurement parameters / limits

Uiso	Nominal test voltage [50 V, 100 V, 250 V, 500 V, 1000 V]
Limit	Min. insulation resistance [Off, Custom, 0.01 MΩ ... 100 MΩ]

Insulation is always measured between all three test leads.

Connection diagrams

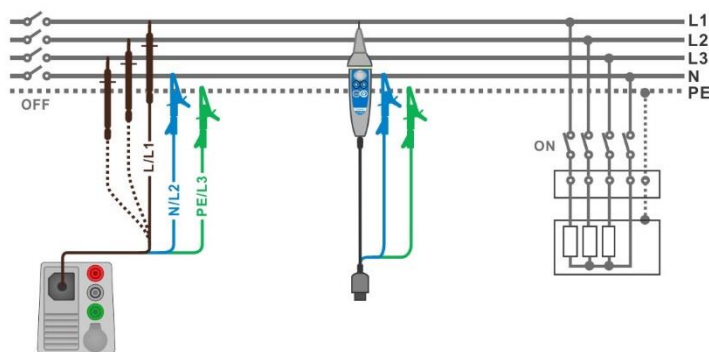

Figure 7.12: Connection of 3-wire test lead and Tip commander

Measurement procedure

- › Enter the **R iso - all** function.
- › Set test parameters / limits.
- › Disconnect tested installation from mains supply and discharge installation as required.
- › Connect test cable to the instrument.
- › Connect test leads to object under test (see **Figure 7.12**).
The standard 3-wire test lead, Plug test cable or Tip commander can be used.
- › Start the measurement.
- › Wait until object under test is fully discharged.
- › Save results (optional).

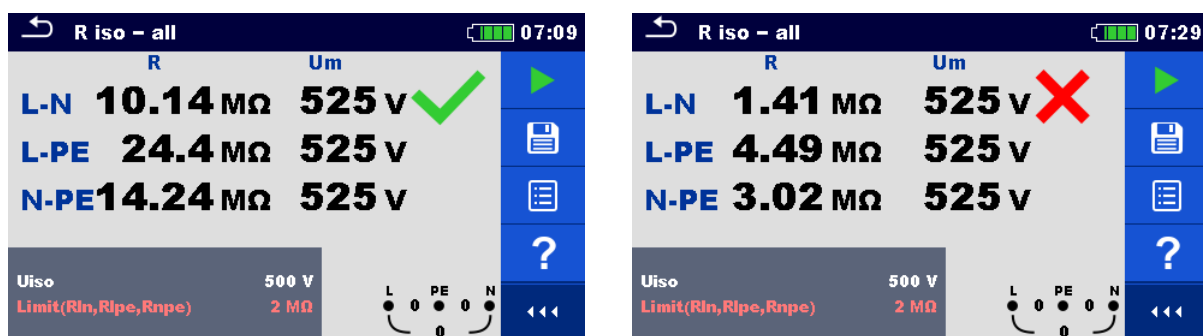

Figure 7.13: Examples of R iso - all measurement result

Measurement results / sub-results

Riso	L-N	Insulation resistance between L and N terminals
	L-PE	Insulation resistance between L and PE terminals
	N-PE	Insulation resistance between N and PE terminals
Um	L-N	Actual test voltage between L and N terminals
	L-PE	Actual test voltage between L and PE terminals
	N-PE	Actual test voltage between N and PE terminals

7.4 The DAR and PI diagnostic

DAR (**D**ielectric **A**bsorption **R**atio) is ratio of insulation resistance values measured after 15 seconds and after 1 minute. The DC test voltage is present during the whole period of the measurement.

$$DAR = \frac{R_{ISO}(1 \text{ min})}{R_{ISO}(15 \text{ s})}$$

PI (**P**olarization **I**ndex) is the ratio of insulation resistance values measured after 1 minute and after 10 minutes. The DC test voltage is present during the whole period of the measurement

$$PI = \frac{R_{ISO}(10 \text{ min})}{R_{ISO}(1 \text{ min})}$$

For additional information regarding PI and DAR diagnostic, please refer to Metrel’s handbook **Modern insulation testing**.

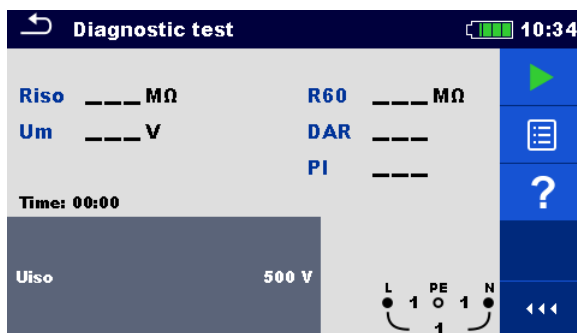

Figure 7.14: Diagnostic test menu

Measurement parameters / limits

Uiso	Nominal test voltage [500 V, 1000 V, 2500 V]
-------------	--

Connection diagrams

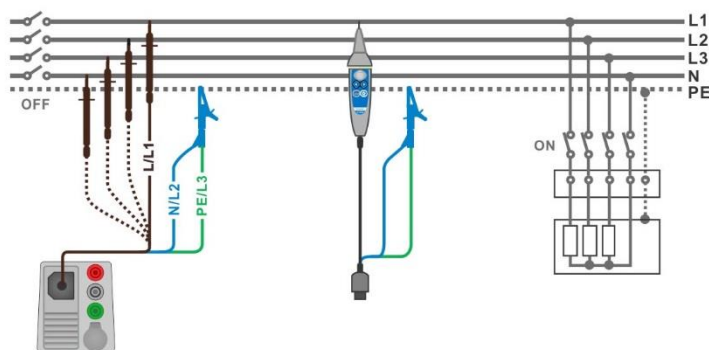

Figure 7.15: Connection of 3-wire test lead and Tip commander ($U_N \leq 1 \text{ kV}$)

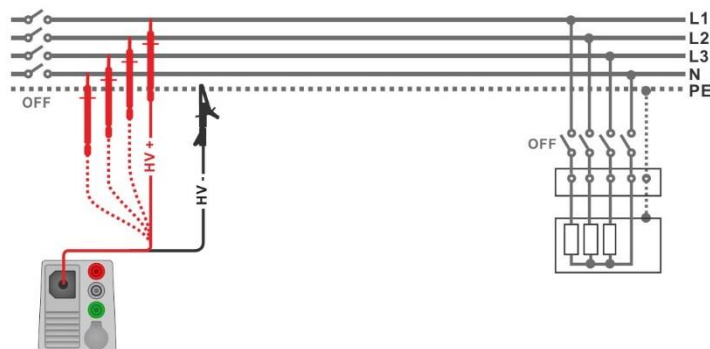

Figure 7.16: Connection of 2.5 kV test lead ($U_N = 2.5 \text{ kV}$)

Measurement procedure

- Enter the **Diagnostic test** function.
- Set test parameters / limits.
- Disconnect tested installation from mains supply and discharge installation as required.
- Connect test cable to the instrument.
- Connect test leads to object under test (see **Figure 7.15** and **Figure 7.16**).
Different test cable must be used for testing with nominal test voltage $U_N \leq 1000 \text{ V}$ and $U_N = 2500 \text{ V}$. Also, different test terminals are used.
The standard 3-wire test lead, Plug test cable or Plug / Tip commanders can be used for the diagnostic test with nominal test voltages $\leq 1000 \text{ V}$. For the 2500 V diagnostic test the two-wire 2.5 kV test lead should be used.
- Start the measurement. Internal timer begins to increment. When internal timer reaches 1 min R60 and DAR factor are displayed and short beep is generated. Measurement can be interrupted at any time.
- When internal timer reaches 10 min also PI factor is displayed and measurement is completed. Wait until object under test is fully discharged.
- After the measurement is finished wait until tested item is fully discharged.
- Save results (optional).

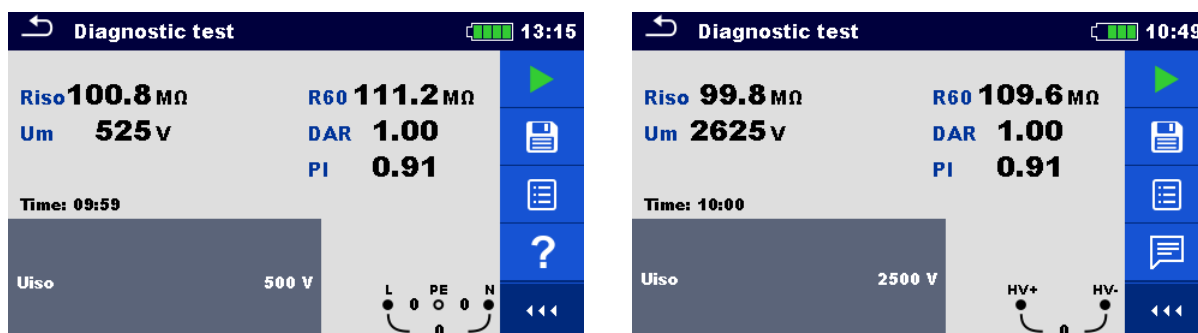

Figure 7.17: Examples of Diagnostic test result

Measurement results / sub-results

Riso	Insulation resistance
Um	Actual test voltage
R60	Resistance after 60 seconds
DAR	Dielectric absorption ratio

PI Polarization index

7.5 Varistor test

Measuring principle

A voltage ramp starts from 50 V and rises with a slope of 100 V/s (Range parameter set to 1000 V) or 350 V/s (Range parameter set to 2500 V). The measurement ends when the defined end voltage is reached or if the test current exceeds the value of 1 mA.

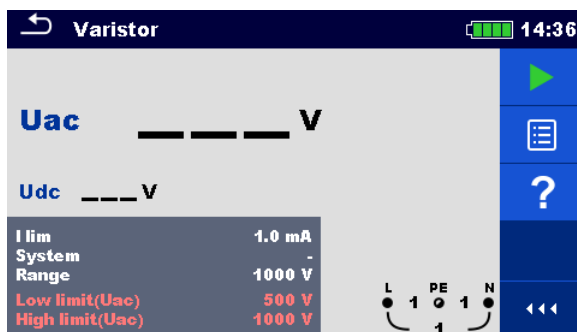

Figure 7.18: Varistor test main menu

Measurement parameters / limits

I lim	Current limit [1.0 mA]
System	System [-, TT, TN, TN-C, TN-S]
Range	Test voltage range [1000 V, 2500 V]
Low limit (Uac)	Low breakdown limit value 1000 V range [Off, 50 V ... 620 V] 2500 V range [Off, 50 V ... 1550 V]
High limit (Uac)	High breakdown limit value 1000 V range [Off, 50 V ... 620 V] 2500 V range [Off, 50 V ... 1550 V]

Test circuit for Varistor test

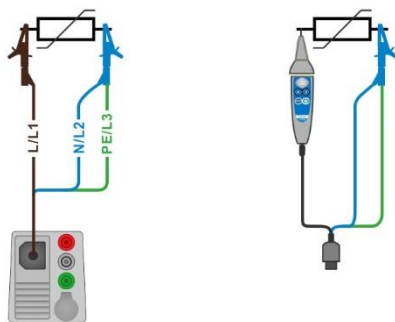

Figure 7.19: Connection of 3-wire test lead and Tip commander (Range: 1000 V)

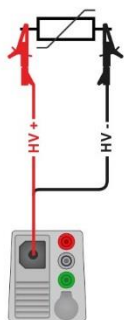

Figure 7.20: Connection of 2.5 kV test lead (Range: 2500 V)

Measurement procedure

- › Enter the **Varistor** test function.
- › Set test parameters / limits.
- › Connect test cable to the instrument.
- › Connect test leads to object under test (see **Figure 7.19** and **Figure 7.20**).
Different test cable must be used if testing at Range: 1000 V or 2500 V. Also different test terminals are used.
The standard 3-wire test lead or Tip commander can be used for the Varistor test when testing at Range: 1000 V. If Range: 2500 V is selected, the two-wire 2.5 kV test lead should be used for the Varistor test.
- › Start the measurement.
The measurement ends when the defined end voltage is reached or if the test current exceeds the value of 1 mA.
- › After the measurement is finished wait until tested item is fully discharged.
- › Save results (optional).

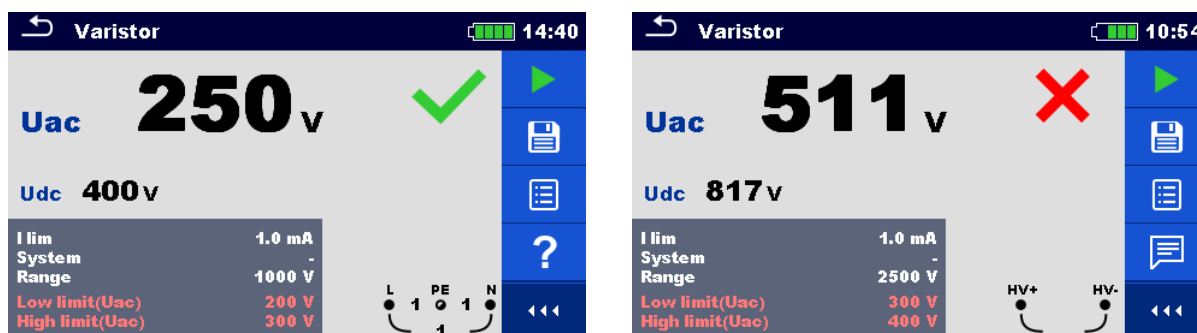

Figure 7.21: Examples of Varistor test result

Measurement results / sub-results

Uac Calculated a.c. breakdown voltage

Udc Breakdown voltage

Meaning of the Uac voltage

Protection devices intended for a.c. network are usually dimensioned approx. 15 % above peak value of the nominal mains voltage. The relation between Udc and Uac is following:

$$U_{ac} \approx \frac{U_{dc}}{1.15 \times \sqrt{2}}$$

Uac voltage may be directly compared with the voltage declared on tested protection device.

7.6 R low – Resistance of earth connection and equipotential bonding

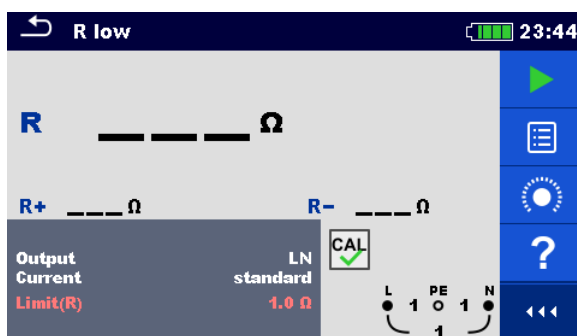

Figure 7.22: R low measurement menu

Measurement parameters / limits

Output¹⁾	[LPE, LN, r1, rn, r2, R1+R2, R2, R1+RN]
Current	[standard, ramp]
Limit(R)	Max. resistance [Off, Custom, 0.1 Ω ... 20.0 Ω]

¹⁾ R low measurement depends on Output parameter setting, see table below.

Output	Test terminals
LN, R1+RN	L and N
LPE, r1, rn, r2, R1+R2, R2	L and PE

Connection diagram, Output: [LPE, LN]

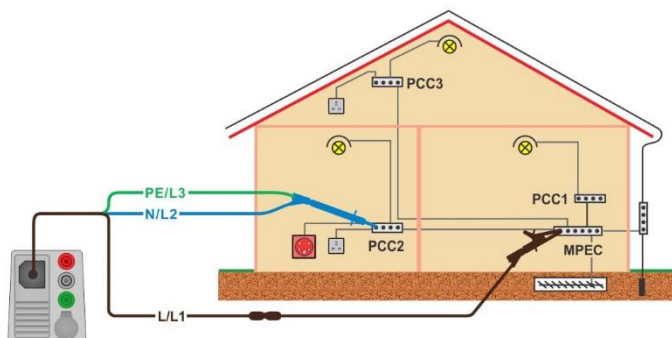

Figure 7.23: Connection of 3-wire test lead plus optional Extension lead (Output LPE or LN)

Connection diagram, Output: [r1, rn, r2, R1+R2, R2, R1+RN]

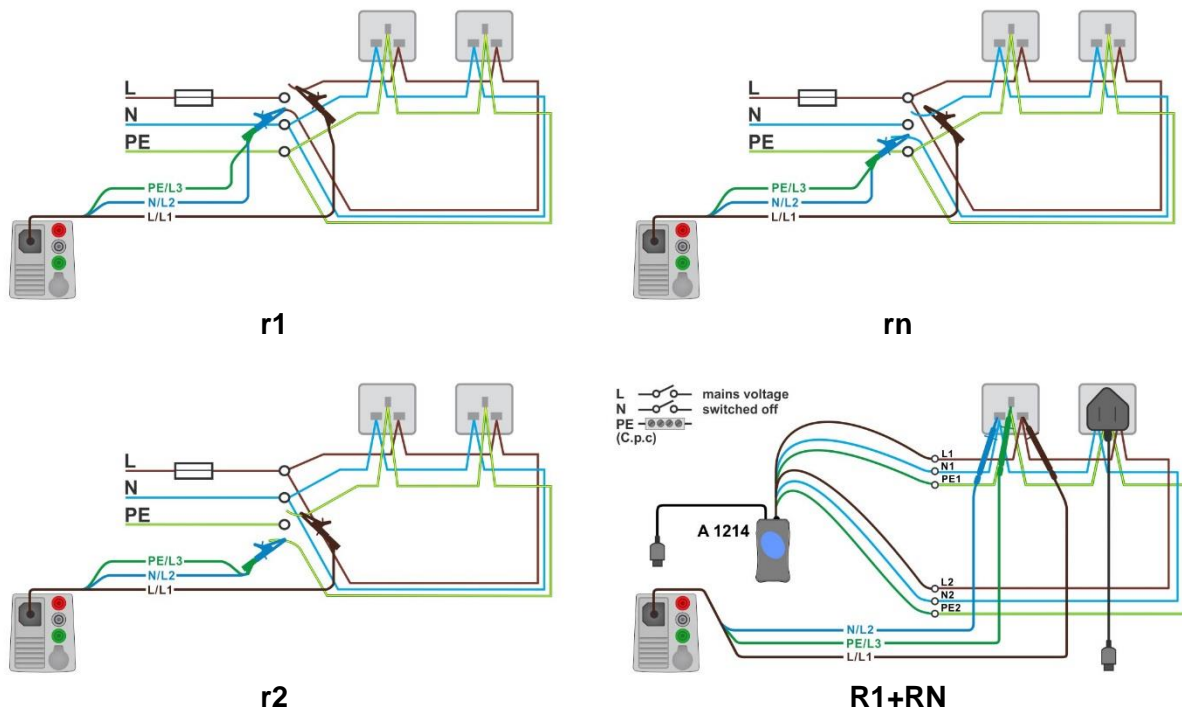

Figure 7.24: Testing r1, rN, r2 and R1+RN sections of the wiring in ring circuits

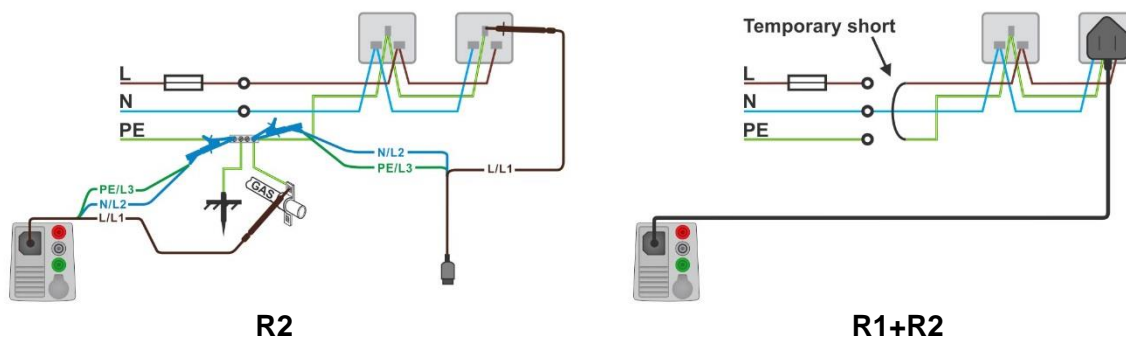

Figure 7.25: Testing R2 and R1+R2 sections of the wiring in final circuits

Measurement procedure

- › Enter the **R low** function.
- › Set test parameters / limits.
- › Connect 3-wire test lead to the instrument.
- › Compensate the test leads resistance if necessary, see section **7.8.1 Compensation of test leads resistance**.
- › Disconnect tested installation from mains supply and discharge insulation as required.
- › Connect test leads, see **Figure 7.23**, **Figure 7.24** and **Figure 7.25**.
- › Start the measurement.
- › Save results (optional).

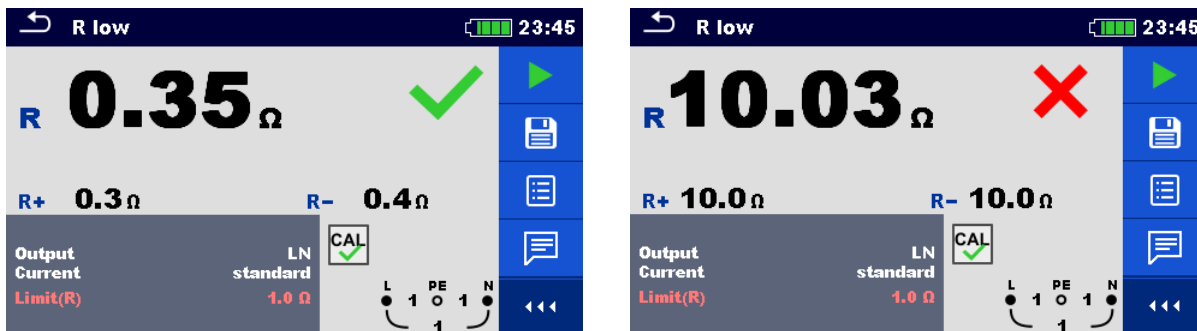

Figure 7.26: Examples of R low measurement result

Measurement results / sub-results

R	Resistance
R+	Result at positive test polarity
R-	Result at negative test polarity

7.7 R low 4W

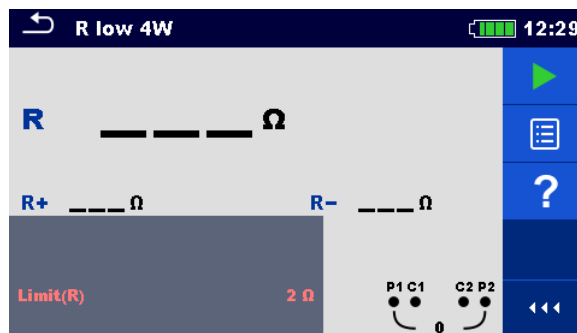

Figure 7.27: R low 4W measurement menu

Measurement parameters / limits

Limit(R)	Max. resistance [Off, Custom, 0.1 Ω ... 20.0 Ω]
----------	---

Connection diagram

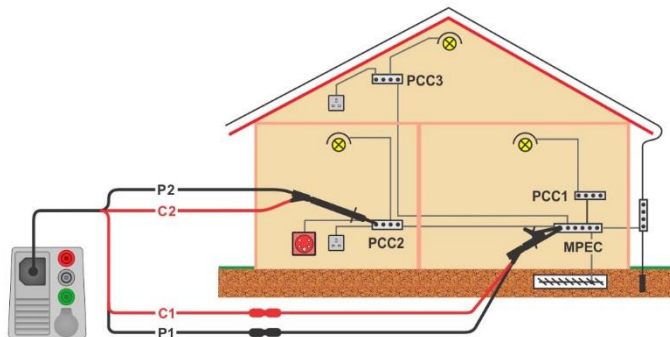

Figure 7.28: Connection of 4-wire test lead plus optional extension leads

Measurement procedure

- › Enter the **R low 4W** function.
- › Set test parameters / limits.
- › Connect 4-wire test lead to the instrument.
- › Disconnect tested installation from mains supply and discharge insulation as required.
- › Connect test leads to device under test, see **Figure 7.28**. Use extension leads if necessary.
- › Start the measurement.
- › Save results (optional).

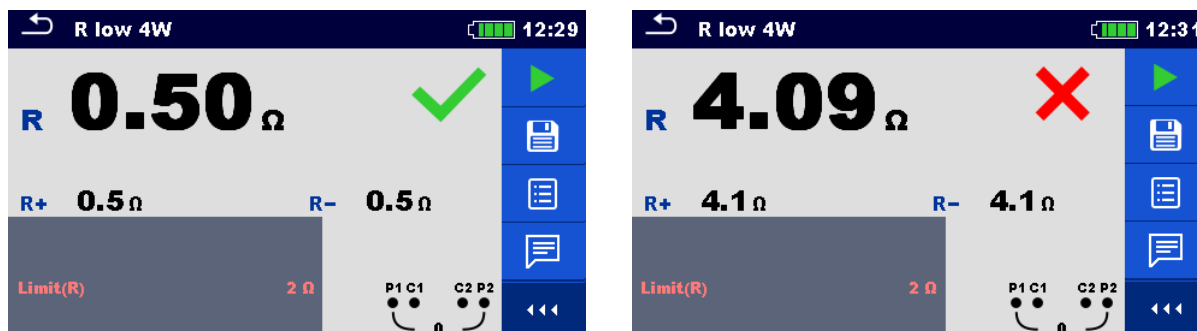

Figure 7.29: Example of R low 4W result

Measurement results / sub-results

- R Resistance
- R+ Result at positive test polarity
- R- Result at negative test polarity

7.8 Continuity – Continuous resistance measurement with low current

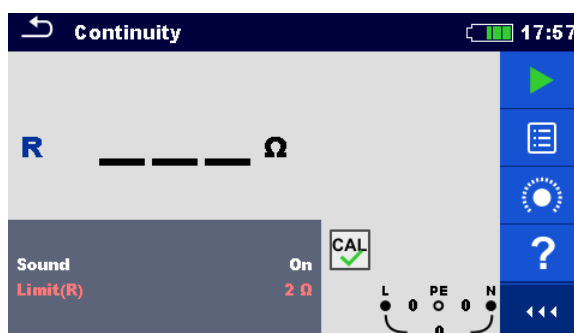

Figure 7.30: Continuity resistance measurement menu

Measurement parameters / limits

- Sound [On*, Off]
- Limit(R) Max. resistance [Off, Custom, 0.1 Ω ... 20.0 Ω]

*Instrument sounds if resistance is lower than the set limit value.

Connection diagrams

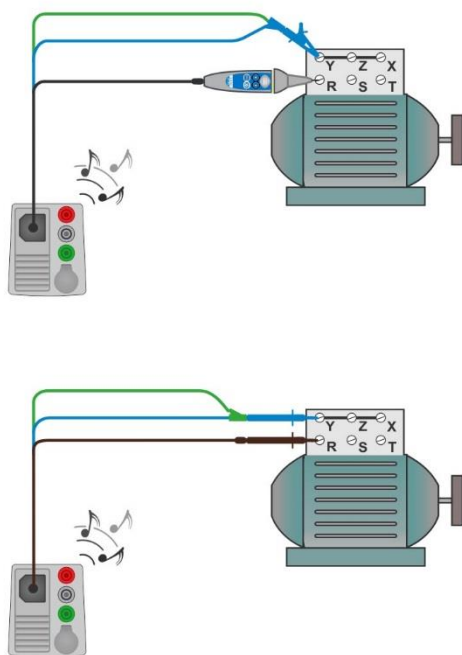

Figure 7.31: Tip commander and 3-wire test lead applications

Measurement procedure

- › Enter the **Continuity** function.
- › Set test parameters / limits.
- › Connect test cable to the instrument.
- › Compensate the test leads resistance if necessary, see section **7.8.1 Compensation of test leads resistance**.
- › Disconnect device under test from mains supply and discharge it as required.
- › Connect test leads to device under test, see **Figure 7.31**.
- › Start the continuous measurement.
- › Stop the measurement.
- › Save results (optional).

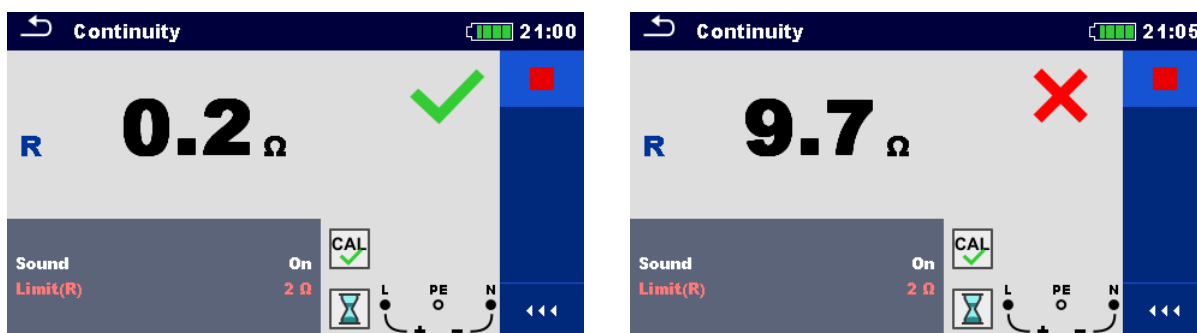



Figure 7.32: Examples of Continuity resistance measurement result

Measurement results / sub-results

R Resistance

7.8.1 Compensation of test leads resistance

This chapter describes how to compensate the test leads resistance in **R low** and **Continuity** functions. Compensation is required to eliminate the influence of test leads resistance and the internal resistances of the instrument on the measured resistance. The lead compensation is therefore a very important feature to obtain correct result.

 symbol is displayed, if the compensation was carried out successfully.

Connections for compensating the resistance of test leads

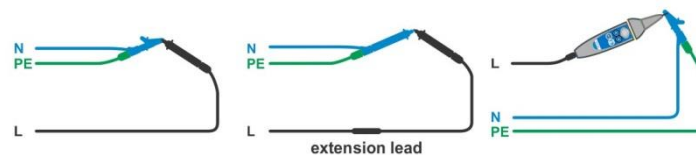



Figure 7.33: Shorted test leads

Compensation of test leads resistance procedure

- › Enter **R low** or **Continuity** function.
- › Connect test cable to the instrument and short all test leads together, see **Figure 7.33**.
- › Touch the  key to compensate leads resistance.

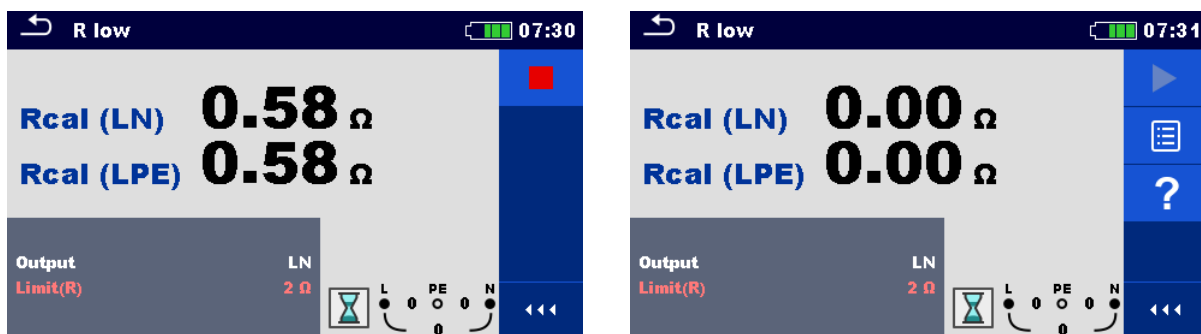

Figure 7.34: Result with old and new calibration values

7.9 Ring continuity (with EASI switch A 1214)



Figure 7.35: Ring continuity measurement menus

Measurement parameters / limits

Test Ring circuit [(r1,r2,rN), (R1+RN,R1+R2)]

Connection diagram

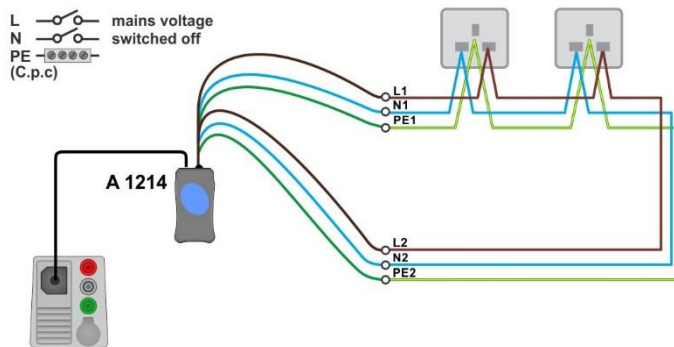

Figure 7.36: Step 1- Measurement of resistance r1, r2 and rN

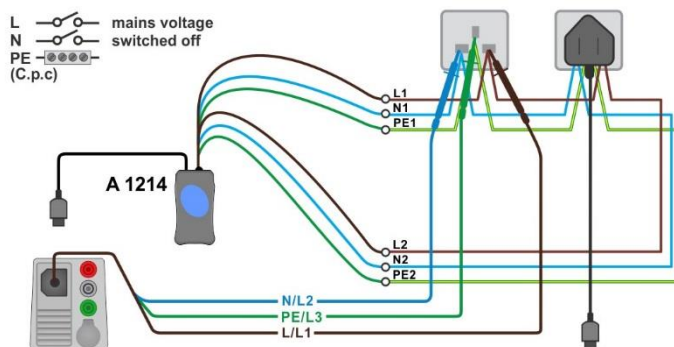

Figure 7.37: Step 2 - Testing R1+RN and R1+R2 sections of the wiring in final circuits

Measurement procedure – Step 1: r1, r2, rN resistances

- › Enter the **Ring Continuity** function.
- › Set Test parameter to (r1,r2,rN).
- › Connect Easy switch A 1214 to the instrument.
- › Connect test leads of Easy switch adapter to the final ring circuit. The electrical installation must be de-energized during the test.
- › Start the measurement. Measurement results are kept until they are changed.
- › Save results (optional).

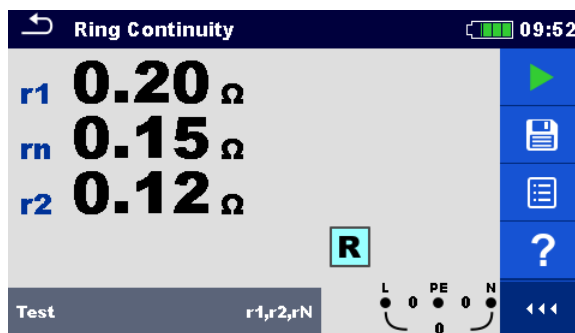

Figure 7.38: Example of r1, r2, rN resistances measurement

Measurement results / sub-results Step 1

r1	Ring resistance of line conductors
rn	Ring resistance of neutral conductors
r2	Ring resistance of protective conductors

Measurement procedure – Step 2: R1+RN and R1+R2 resistances

- › Easy switch A 1214 must stay connected to the final ring continuity. The electrical installation must be de-energized during the test.
- › Set test parameter to [R1+RN, R1+R2].
- › Connect Plug cable or Test cable to the instrument.
- › Connect Plug cable or Test cable to a socket in final ring circuit.
- › Start the measurement.
For correct ring wiring the results must be approximately the same as reference value $(r1+rN)/4$ and $(r1+r2)/4$. The resistance R1+R2 slightly increases with length if cross-section of PE conductor is smaller than of line conductor.
- › Commit results to values on positions R1+RN c and R1+R2 c.
- › Repeat the measurements on all sockets of the final ring circuit. For each measurement commit results to values on positions R1+RN c and R1+R2 c. The results will be committed only if they are higher as the previous results.
- › Save results (optional).



Figure 7.39: Examples of Ring Continuity measurement result

Measurement results / sub-results

R1+RN c	Reference test value, committed and measured values
R1+R2 c	Reference test value, committed and measured values
$(r1+rN)/4$	Calculated reference value
$(r1+r2)/4$	Calculated reference value

7.10 Testing RCDs

Various test and measurements are required for verification of RCD(s) in RCD protected installations. Measurements are based on the EN 61557-6 standard.

The following measurements and tests (sub-functions) can be performed:

- › Contact voltage,
- › Trip-out time,
- › Trip-out current and
- › RCD Auto test.

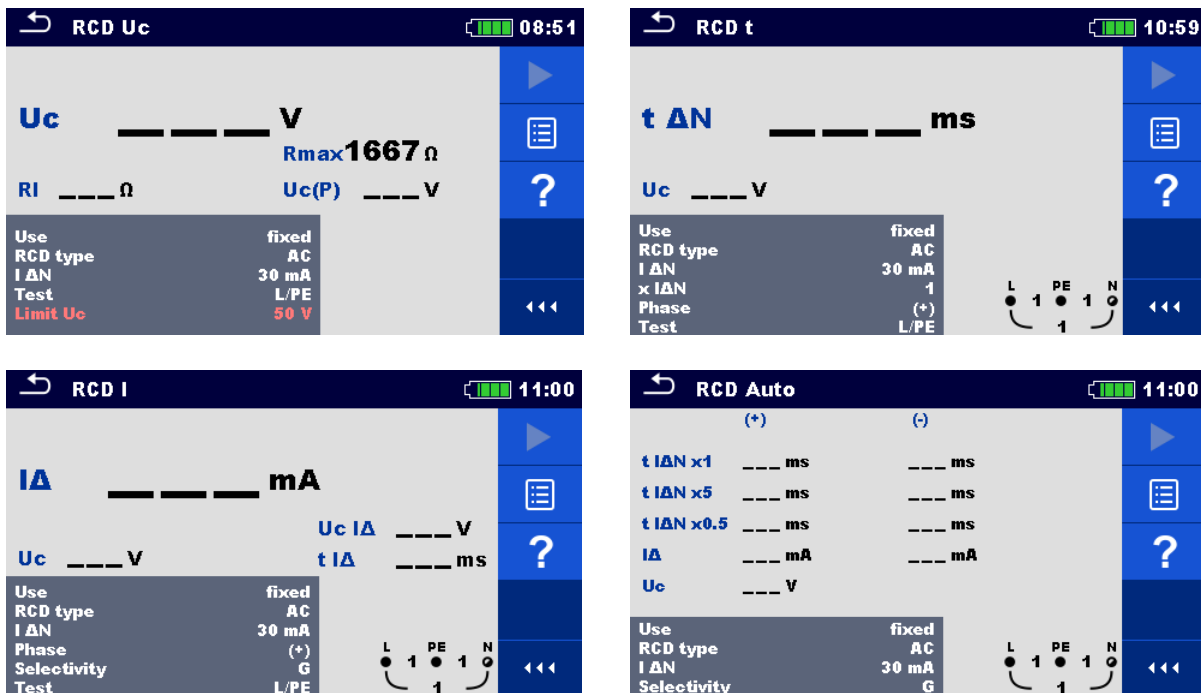

Figure 7.40: RCD menus

Test parameters / limits

$I \Delta N$	Rated RCD residual current sensitivity [10 mA, 15 mA, 30 mA, 100 mA, 300 mA, 500 mA, 1000 mA]
$I \Delta N / I \Delta N_{dc}$	Rated RCD residual current sensitivity for special RCD types [30 mA / 6 mA d.c., - / 6 mA d.c.] ¹⁾
RCD type	RCD type [AC, A, F, B, B+, EV RCD ¹⁾ , MI RCD ¹⁾ , EV RCM ¹⁾]
Use	RCD / PRCD selection [fixed, PRCD, PRCD-2p, PRCD-3p, PRCD-S, PRCD-S+, PRCD-K, other]
Selectivity	Characteristic [G, S]
$x I \Delta N$	Multiplication factor for test current [0.5, 1, 2, 5]
$x I \Delta N$ d.c.	Multiplication factor for d.c. test current [0.5, 1, 10, 33.33, 50] ¹⁾
Phase	Starting polarity [(+), (-), (+,-)]
Test	Test [-, L/PE, L1/PE, L2/PE, L3/PE]
Test	Test current shape [a.c., d.c.] ²⁾
Sensitivity	Sensitivity [standard, I _{pe} monitoring] ³⁾
Uc (P)	Contact voltage, external probe [On, Off]
Limit Uc	Conventional touch voltage limit [Custom, 12 V, 25 V, 50 V]

RCD Standard	Refer to chapter 4.6.8.2 RCD standard for more information.
EV RCD/RCM Standard	Refer to chapter 4.6.8.3 EV RCD/RCM standards for more information.
Earthing system	Refer to chapter 4.6.8 Settings for more information.

- 1) Parameter is available only when parameter Use is set to other (for Electrical Vehicle (EV) RCDs/RCMs and Mobile installations (MI) RCDs).
- 2) Parameter is available only when RCD I or RCD t test is selected and parameter Use is set to 'other'.
- 3) Parameter is available only when parameter 'Use' is set to PRCD, PRCD-3p, PRCD-S+ or PRCD-K.

Connection diagrams

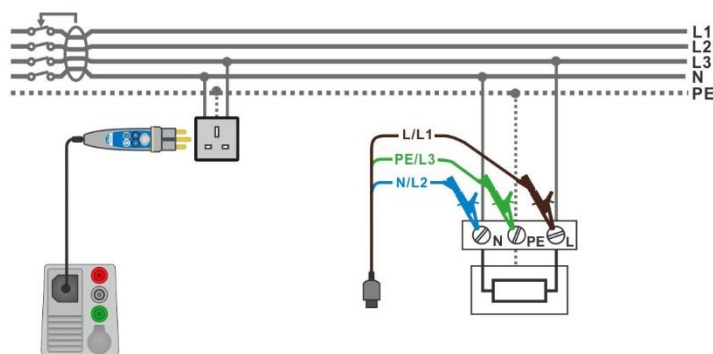

Figure 7.41: Connecting the Plug commander and the 3-wire test lead

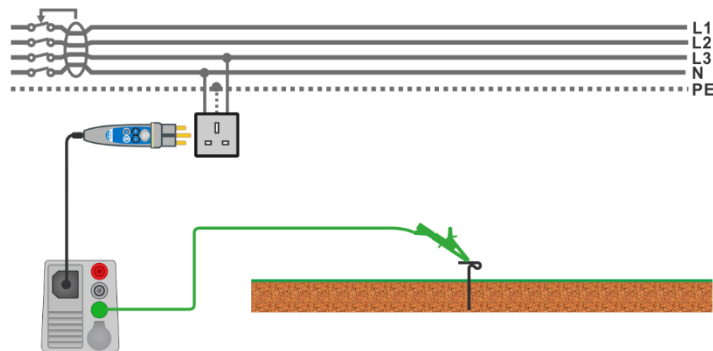

Figure 7.42: Connection for $U_c(P)$ measurement

7.10.1 RCD U_c – Contact voltage

Measuring current up to $\frac{1}{3}$ of nominal residual current is used for measurement of contact voltage.

Contact voltage measurement is performed before trip-out time/current tests. If limit voltage (e.g. 50 V) is reached during this pre-test, trip-out test is aborted for safety reason.

7.10.1.1 RCD Uc(P) – Contact voltage with external probe

Contact voltage measurement can also be performed using external test probe. Place external probe to reference earth potential.

For connection see **Figure 7.42 Connection for Uc(P) measurement**.

Before the contact voltage measurement make sure that Uc(P) parameter is set to On.

Test procedure

- › Enter the **RCD Uc** function.
- › Set test parameters / limits.
- › Connect test cables to the instrument.
- › Connect L, N and PE of 3-wire test lead or Plug commander to the object under test, see **Figure 7.41**.
- › Connect test lead to P/S terminal and external earthed point (optional), see **Figure 7.42**.
- › Start the measurement.
- › Save results (optional).

The contact voltage results U_c and $U_c(P)$ relate to the rated nominal residual current of the RCD and are multiplied by an appropriate factor (depending on RCD type and type of test current). The 1.05 factor is applied to avoid negative tolerance of result. See **Table 7.3** for detailed contact voltage calculation factors.

RCD type		Contact voltages U_c and $U_c(P)$ proportional to	Rated $I_{\Delta N}$
AC, EV, MI (a.c. part)	G	$1.05 \times I_{\Delta N}$	any
AC	S	$2 \times 1.05 \times I_{\Delta N}$	
A, F	G	$1.4 \times 1.05 \times I_{\Delta N}$	≥ 30 mA
A, F	S	$2 \times 1.4 \times 1.05 \times I_{\Delta N}$	
A, F	G	$2 \times 1.05 \times I_{\Delta N}$	< 30 mA
A, F	S	$2 \times 2 \times 1.05 \times I_{\Delta N}$	
B, B+	G	$2 \times 1.05 \times I_{\Delta N}$	any
B, B+	S	$2 \times 2 \times 1.05 \times I_{\Delta N}$	

Table 7.3: Relation between U_c , $U_c(P)$ and $I_{\Delta N}$

Fault Loop resistance is indicative and calculated from U_c result (without additional proportional factors) according to: $R_L = \frac{U_c}{I_{\Delta N}}$.

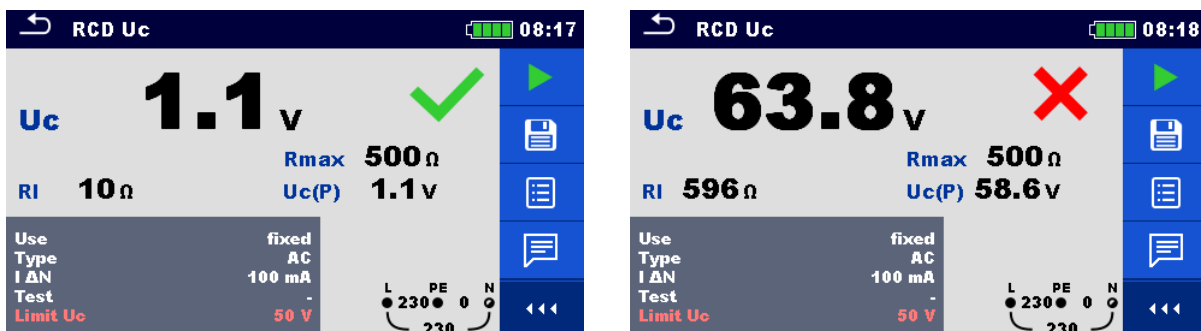

Figure 7.43: Examples of Contact voltage measurement result

Test result / sub-results

Uc	Contact voltage
Uc(P) – if selected	Contact voltage, external probe
RI	Fault loop resistance
Rmax	Maximum earth fault loop resistance value according to BS 7671

7.10.2 RCD t – Trip-out time**Test procedure**

- › Enter the **RCD t** function.
- › Set test parameters / limits.
- › Connect test cable to the instrument.
- › Connect 3-wire test lead or Plug commander to the object under test, see **Figure 7.41**.
- › Start the measurement.
- › Save results (optional).



Figure 7.44: Examples of Trip-out time measurement result

Test results / sub-results

t ΔN	Trip-out time
Uc	Contact voltage for rated I _{ΔN}

7.10.3 RCD I – Trip-out current

The instrument increases the test current in small steps through appropriate range as follows:

RCD type	Slope range		Waveform
	Start value	End value	
AC	$0.2 \times I_{\Delta N}$	$1.1 \times I_{\Delta N}$	Sine
IEC 62752: EV RCD, EV RCM, MI RCD (a.c. part)	$0.2 \times I_{\Delta N}$	$1.0 \times I_{\Delta N}$	Sine
IEC 62955: EV RCD, EV RCM, MI RCD (a.c. part)	$0.2 \times I_{\Delta N}$	$1.0 \times I_{\Delta N}$	Sine
A, F ($I_{\Delta N} \geq 30$ mA)	$0.2 \times I_{\Delta N}$	$1.5 \times I_{\Delta N}$	Pulsed
A, F ($I_{\Delta N} = 10$ mA)	$0.2 \times I_{\Delta N}$	$2.2 \times I_{\Delta N}$	
B, B+	$0.2 \times I_{\Delta N}$	$2.2 \times I_{\Delta N}$	DC
IEC 62752: EV RCD, EV RCM, MI RCD (d.c. part)	1.2 mA	6.0 mA	DC

IEC 62955: EV RCD, EV RCM, MI RCD (d.c. part)	1.2 mA	6.0 mA	DC
--	--------	--------	----

Table 7.4: Relation between RCD type, slope range and test current

Maximum test current is I_{Δ} (trip-out current) or end value in case the RCD didn't trip-out.

Test procedure

- › Enter the **RCD I** function.
- › Set test parameters / limits.
- › Connect test cable to the instrument.
- › Connect 3-wire test lead or Plug commander to the object under test, see **Figure 7.41**.
- › Start the measurement.
- › Save results (optional).

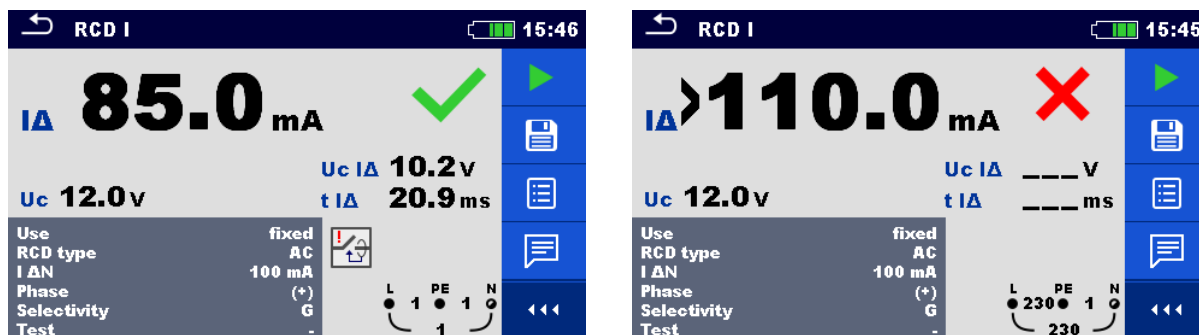

Figure 7.45: Examples of Trip-out current measurement result

Test results / sub-results

I_{Δ}	Trip-out current
U_c	Contact voltage
$U_c I_{\Delta}$	Contact voltage at trip-out current I_{Δ} or end value if the RCD didn't trip
$t I_{\Delta}$	Trip-out time at trip-out current I_{Δ}

7.10.4 RCD Auto – RCD Auto test

RCD Auto test function performs a complete RCD test (trip-out time at different residual currents, trip-out current and contact voltage) in one set of automatic tests, guided by the instrument.

RCD Auto test procedure

RCD Auto test steps	Notes
› Enter the RCD Auto function.	
› Set test parameters / limits.	
› Connect test cable to the instrument.	
› Connect 3-wire test lead or Plug commander to the object under test, see Figure 7.41	
› Start the measurement.	Start of test

Test with $I_{\Delta N}$ d.c., (+) positive polarity (step 1) ¹⁾ .	RCD should trip-out
Re-activate RCD.	
Test with $I_{\Delta N}$ d.c., (-) negative polarity (step 2) ¹⁾ .	RCD should trip-out
Re-activate RCD.	
Test with $I_{\Delta N}$, (+) positive polarity (step 3) ²⁾ .	RCD should trip-out RCD should not trip-out during non-operating time for a.c. residual current (IEC 62955).
<ul style="list-style-type: none"> › Re-activate RCD if required. 	
Test with $I_{\Delta N}$, (-) negative polarity (step 4) ²⁾ .	RCD should trip-out RCD should not trip-out during non-operating time for a.c. residual current (IEC 62955).
<ul style="list-style-type: none"> › Re-activate RCD if required. 	
Test with $5 \times I_{\Delta N}$, (+) positive polarity (step 5) ²⁾ .	RCD should trip-out
<ul style="list-style-type: none"> › Re-activate RCD. 	
Test with $5 \times I_{\Delta N}$, (-) negative polarity (step 6) ²⁾ .	RCD should trip-out
<ul style="list-style-type: none"> › Re-activate RCD. 	
Test with $\frac{1}{2} \times I_{\Delta N}$, (+) positive polarity (step 7) ²⁾ .	RCD should not trip-out
Test with $\frac{1}{2} \times I_{\Delta N}$, (-) negative polarity (step 8) ²⁾ .	RCD should not trip-out
Trip-out current test, (+) positive polarity (step 9) ²⁾ .	RCD should trip-out
<ul style="list-style-type: none"> › Re-activate RCD. 	
Trip-out current test, (-) negative polarity (step 10) ²⁾ .	RCD should trip-out
<ul style="list-style-type: none"> › Re-activate RCD¹⁾. 	
Trip-out current test for d.c. part, (+) polarity (step 11).	RCD should trip-out
<ul style="list-style-type: none"> › Re-activate RCD¹⁾. 	
Trip-out current test for d.c. part, (-) polarity (step 12).	RCD should trip-out
Re-activate RCD.	
Save results (optional).	End of test

¹⁾ Steps 1, 2 11 and 12 are performed only when parameter Use is set to 'other' and parameter Type is set to 'EV RCD', 'EV RCM' or 'MI RCD'. Trip-out times are measured according to IEC 62752 or IEC 62955.

²⁾ When parameter Use is set to 'other' and parameter Type is set to 'EV RCD', 'EV RCD' or 'MI RCD', trip-out times or non-operating times for a.c. residual current are measured according to IEC 62752 or IEC 62955.

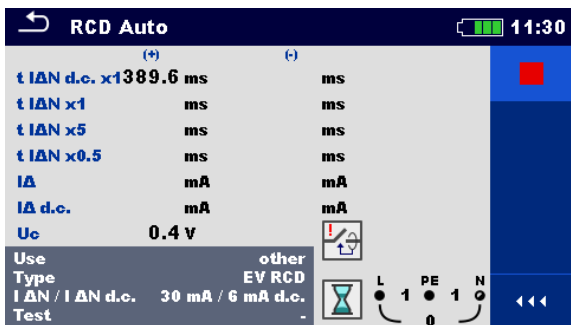

Step 1

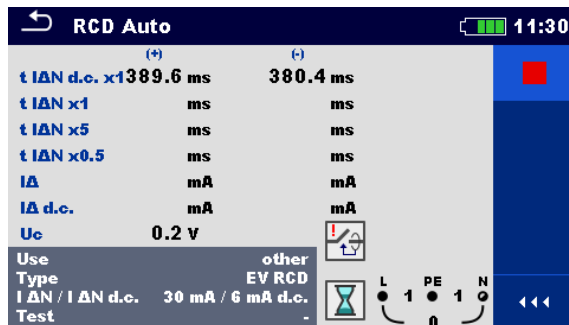

Step 2

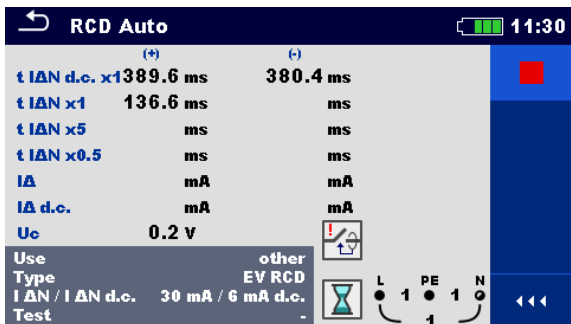

Step 3

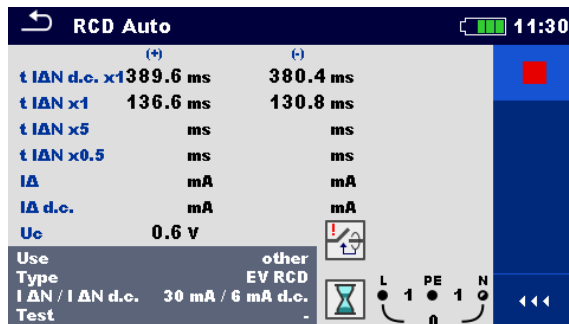

Step 4

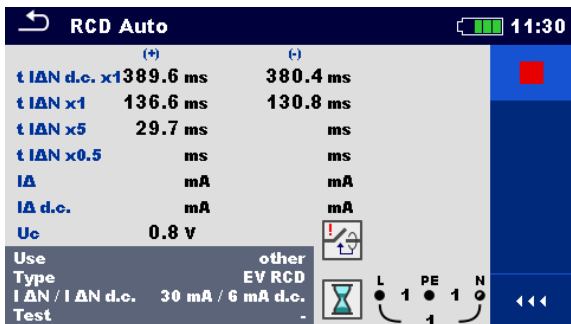

Step 5

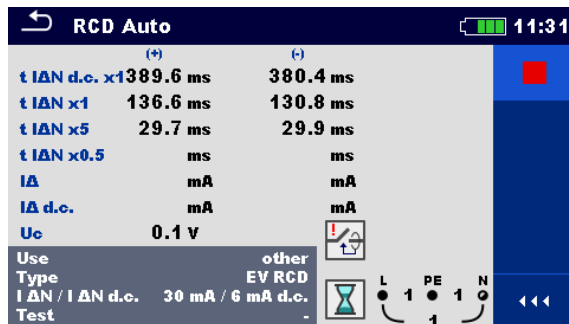

Step 6

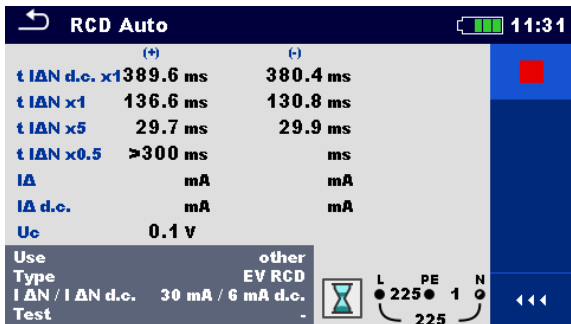

Step 7

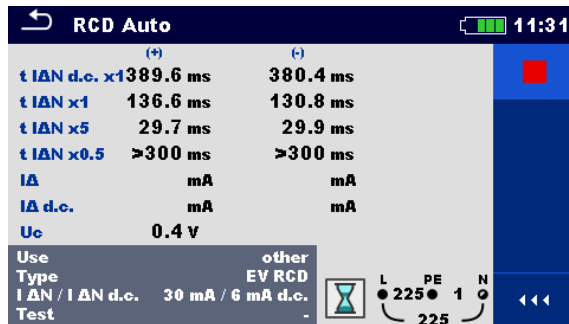

Step 8



Figure 7.46: Individual steps in RCD Auto test

Test results / sub-results

t I Δ N d.c. x1, (+) ¹⁾	Step 1 trip-out time (I Δ =I Δ N d.c., (+) positive polarity)
t I Δ N d.c. x1, (-) ¹⁾	Step 2 trip-out time (I Δ =I Δ N d.c., (-) negative polarity)
t I Δ N x1, (+)	Step 3 trip-out time (I Δ =I Δ N, (+) positive polarity) Non-operating time for a.c. current (IEC 62955).
t I Δ N x1, (-)	Step 4 trip-out time (I Δ =I Δ N, (-) negative polarity) Non-operating time for a.c. current (IEC 62955).
t I Δ N x5, (+)	Step 5 trip-out time (I Δ =5×I Δ N, (+) positive polarity)
t I Δ N x5, (-)	Step 6 trip-out time (I Δ =5×I Δ N, (-) negative polarity)
t I Δ N x0.5, (+)	Step 7 trip-out time (I Δ =½×I Δ N, (+) positive polarity)
t I Δ N x0.5, (-)	Step 8 trip-out time (I Δ =½×I Δ N, (-) negative polarity)
I Δ (+)	Step 9 trip-out current ((+) positive polarity)
I Δ (-)	Step 10 trip-out current ((-) negative polarity)
I Δ (d.c,+)	Step 11 trip-out current ((+) positive polarity) ¹⁾
I Δ (d,c,-)	Step 12 trip-out current ((-) negative polarity) ¹⁾
Uc	Contact voltage for rated I Δ N

¹⁾ Result is displayed only when parameter Use is set to 'other' and parameter Type to 'EV RCD', 'EV RCM' or 'MI RCD'.

7.11 Z loop – Fault loop impedance and prospective fault current

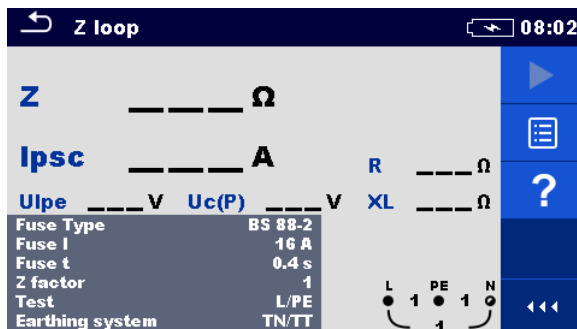

Figure 7.47: Z loop menu

Measurement parameters / limits

Fuse Type	Selection of fuse type [Off, Custom, BS 88-2, BS 88-3, BS 3036, BS 1362, B, C, D]
Fuse I	Rated current of selected fuse
Fuse t	Maximum breaking time of selected fuse
Z factor	Z factor [Custom, 0.8, 1]
Test¹⁾	Selection of test [-, L/PE, L1/PE, L2/PE, L3/PE]
Uc (P)	Contact voltage measurement with external probe [Off, On]
Earthing system	Refer to chapter 4.6.8 Settings for more information.
Zlim(Z)	Maximum loop impedance for selected fuse or custom value
Limit Uc	Contact voltage Uc (P) limit [Custom, 12 V, 25 V, 50 V]

¹⁾ With Plug test cable or Plug commander Z loop is measured in the same way regardless of the setting. The parameter is meant for documentation.

Refer to **Fuse tables guide** for detailed information on fuse data.

Connection diagrams

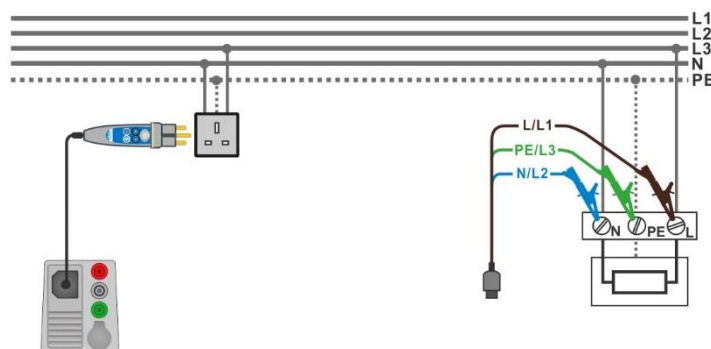
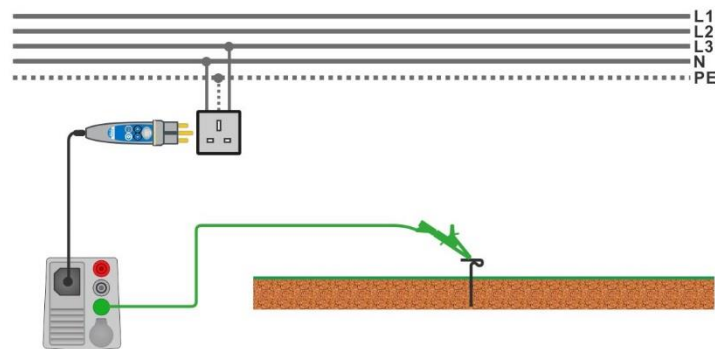

Figure 7.48: Connection of Plug commander and 3-wire test lead

Figure 7.49: Connection for $U_c(P)$ measurement

Measurement procedure

- › Enter the **Z loop** function.
- › Set test parameters / limits.
- › Connect test cable to the instrument.
- › Connect 3-wire test lead or Plug commander to the object under test, see **Figure 7.48**.
- › Connect test lead P/S to external earthed point (optional), see **Figure 7.49**.
- › Start the measurement.
- › Save results (optional).

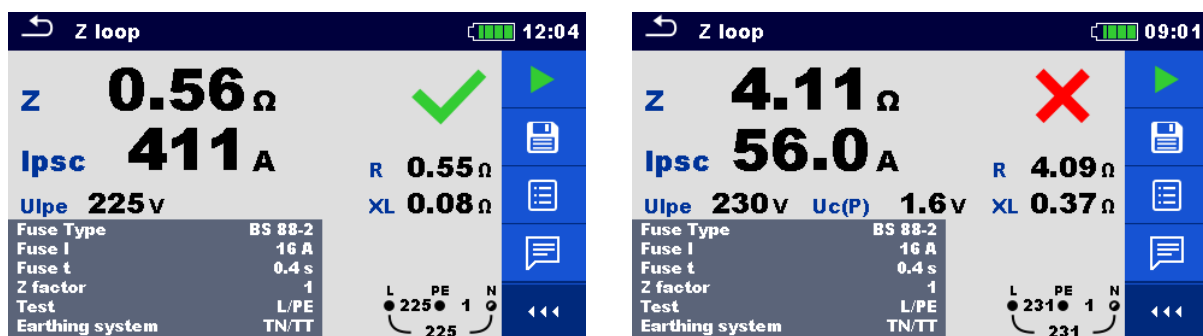

Figure 7.50: Examples of Loop impedance measurement result

Measurement results / sub-results

Z	Loop impedance
IpSC	Prospective fault current
Ulpe	Voltage L-PE
R	Resistance of loop impedance
XL	Reactance of loop impedance
Uc (P)	Contact voltage at prospective fault current (external probe)

Prospective fault current I_{PSC} is calculated from measured impedance as follows:

$$I_{PSC} = \frac{U_n}{Z}$$

Loop impedance limit $Z_{Lim(Z)}$ for selected fuse is calculated from the following formula:

$$Z_{Lim(Z)} = \text{Scaling_factor} \times Z_{Lim}$$

where:

- Z_{Lim} Maximum loop impedance for selected fuse (according to BS 7671)
- Scaling factor Impedance correction factor (Z factor) (see chapter 4.6.8 Settings)
- U_n Nominal U_{L-PE} voltage (see table below)
- U_c(P) Voltage between external earthed point and main earthing point (P/S and PE terminals), see calculation below

U _n	Input voltage range (L-PE)
110 V	(93 V ≤ U _{L-PE} ≤ 134 V)
230 V	(185 V ≤ U _{L-PE} ≤ 266 V)

Table 7.5: Relation between Input voltage – U_{L-PE} and nominal voltage – U_n used for calculation

U_c(P) calculation

$$U_C(P) = Z_{PE-P/S} \times I_{PSC}$$

7.12 Z loop 4W – Fault loop impedance and prospective fault current

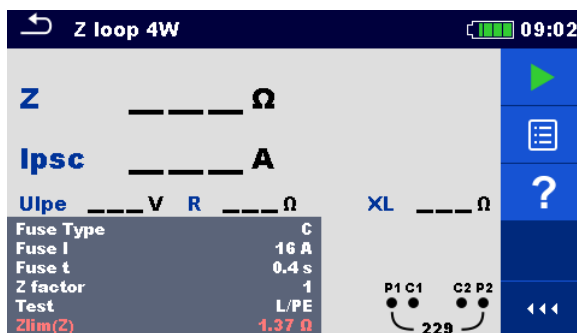

Figure 7.51: Z loop 4W menu

Measurement parameters / limits

Fuse Type	Selection of fuse type [Off, Custom, BS 88-2, BS 88-3, BS 3036, BS 1362, B, C, D]
Fuse I	Rated current of selected fuse
Fuse t	Maximum breaking time of selected fuse
Z factor	Z factor [Custom, 0.8, 1]
Test	Selection of test [-, L-PE, L1-PE, L2-PE, L3-PE]
Zlim(Z)	Maximum loop impedance for selected fuse or custom value

Refer to **Fuse tables guide** for detailed information on fuse data.

Connection diagram

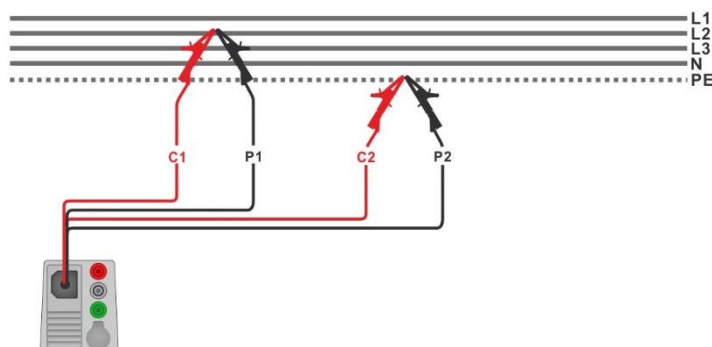

Figure 7.52: Connection of 4-wire test lead

Measurement procedure

- ▶ Enter the **Z loop 4W** function.
- ▶ Set test parameters / limits.
- ▶ Connect test cable to the instrument.
- ▶ Connect 4-wire test lead to the object under test, C1, P1 terminals to phase and C2, P2 terminals to PE; see **Figure 7.52**.
- ▶ Start the measurement.
- ▶ Save results (optional).

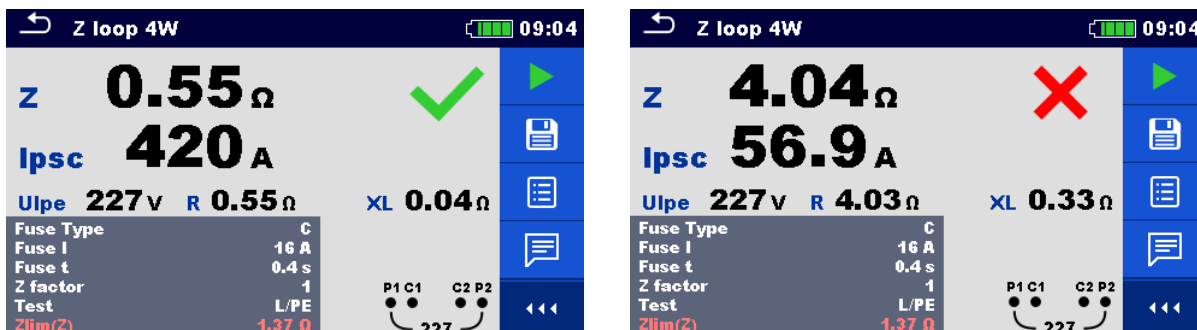

Figure 7.53: Example of 4W loop impedance measurement result

Measurement results / sub-results

Z	Loop impedance
Ipsc	Prospective fault current
Ulpe	Voltage L-PE
R	Resistance of loop impedance
XL	Reactance of loop impedance

Prospective fault current I_{PSC} is calculated from measured impedance as follows:

$$I_{PSC} = \frac{U_n}{Z}$$

Loop impedance limit $Z_{Lim(Z)}$ for selected fuse is calculated from the following formula:

$$Z_{Lim(Z)} = \text{Scaling_factor} \times Z_{Lim}$$

where:

Z_{Lim} Maximum loop impedance for selected fuse (according to BS 7671)

Scaling factor..... Impedance correction factor (Z factor) (see chapter **4.6.8 Settings**)

U_n Nominal U_{L-PE} voltage (see table below)

U_n	Input voltage range (L-PE)
110 V	$(93 \text{ V} \leq U_{L-PE} \leq 134 \text{ V})$
230 V	$(185 \text{ V} \leq U_{L-PE} \leq 266 \text{ V})$

Table 7.6: Relation between Input voltage – U_{L-PE} and nominal voltage – U_n used for calculation

7.13 Zs rcd – Fault loop impedance and prospective fault current in system with RCD

Zs rcd measurement prevents trip-out of the RCD in systems with the RCD.

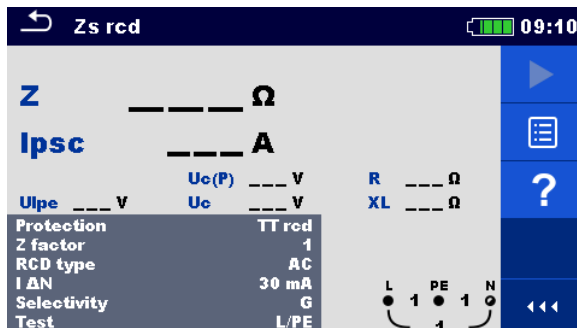

Figure 7.54: Zs rcd menu

Measurement parameters / limits

Protection	Protection type [TN, TT rcd]
Fuse Type¹⁾	Selection of fuse type [Off, Custom, BS 88-2, BS 88-3, BS 3036, BS 1362, B, C, D]
Fuse I¹⁾	Rated current of selected fuse
Fuse t¹⁾	Maximum breaking time of selected fuse
Z factor	Z factor [Custom, 0.8, 1]
RCD type²⁾	RCD type [AC, A, F, B, B+]
I ΔN²⁾	Rated RCD residual current sensitivity [10 mA, 30 mA, 100 mA, 300 mA, 500 mA, 1000 mA]
Selectivity²⁾	Characteristic [G, S]
Test³⁾	Selection of test [-, L-PE, L1-PE, L2-PE, L3-PE]
Uc (P)	Contact voltage measurement with external probe [On, Off]
I test	Test current [Standard, Low]
Zlim(Z)¹⁾	Maximum loop impedance for selected fuse or custom value
Limit Uc²⁾	Contact voltage limit [Custom, 12 V, 25 V, 50 V]

- 1) Parameter or limit is considered if Protection is set to TN.
- 2) Parameter or limit is considered if Protection is set to TT rcd.
- 3) With Plug test cable or Plug commander Zs rcd test is measured in the same way regardless of the setting. The parameter is meant for documentation.

Refer to **Fuse tables guide** for detailed information on fuse data.

Connection diagrams

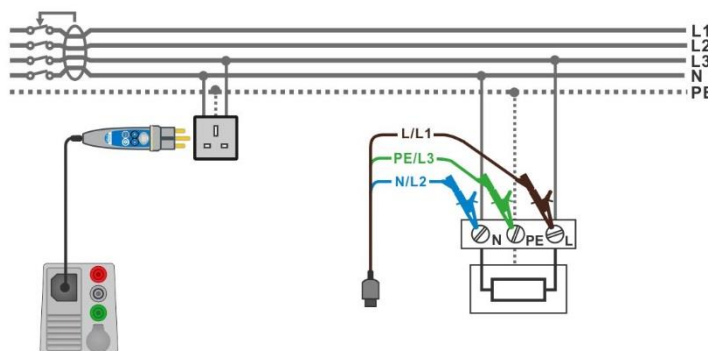
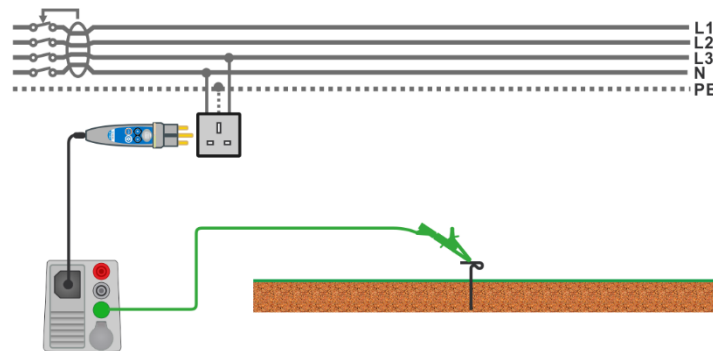

Figure 7.55: Connection of Plug commander and 3-wire test lead

Figure 7.56: Connection for $U_c(P)$ measurement

Measurement procedure

- › Enter the **Zs rcd** function.
- › Set test parameters / limits.
- › Connect test cable to the instrument.
- › Connect 3-wire test lead or Plug commander to the object under test, see **Figure 7.55**.
- › Connect test lead P/S to external earthed point (optional), see **Figure 7.56**.
- › Start the measurement.
- › Save results (optional).



Figure 7.57: Examples of Zs rcd measurement result

Measurement results / sub-results

Z	Loop impedance
Ipsc	Prospective fault current
Ulpe	Voltage L-PE
Uc ¹⁾	Contact voltage at nominal residual current
Uc (P) ¹⁾	Contact voltage at prospective fault current (external probe) ²⁾
	Contact voltage at nominal residual current (external probe) ³⁾
R	Resistance of loop impedance
XL	Reactance of loop impedance

¹⁾ Result is presented only if Protection is set to TTrcd.

²⁾ Protection type parameter set to TN.

³⁾ Protection type parameter set to TTrcd.

Prospective fault current I_{PSC} is calculated from measured impedance as follows:

$$I_{PSC} = \frac{U_n}{Z}$$

Loop impedance limit $Z_{Lim(Z)}$ for selected fuse is calculated from the following formula:

$$Z_{Lim(Z)} = Scaling_factor \times Z_{Lim}$$

where:

- Z_{Lim} Maximum loop impedance for selected fuse
- Scaling factor..... Impedance correction factor (Z factor) (see chapter 4.6.8 Settings)
- U_n Nominal U_{L-PE} voltage (see table below)
- $U_c(P)$ Voltage between external earthed point and main earthing point (P and PE terminals), see calculation below

U_n	Input voltage range (L-PE)
110 V	$(93\text{ V} \leq U_{L-PE} \leq 134\text{ V})$
230 V	$(185\text{ V} \leq U_{L-PE} \leq 266\text{ V})$

Table 7.7: Relation between Input voltage – U_{L-PE} and nominal voltage – U_n used for calculation

$U_c(P)$ calculation

$$U_c(P) = \begin{cases} Z_{PE-P/S} \times I_{\Delta N}, & \text{Protection} = \text{TTrcd} \\ Z_{PE-P/S} \times I_{PFC}, & \text{Protection} = \text{TN} \end{cases}$$

7.14 Z loop mΩ – High precision fault loop impedance and prospective fault current

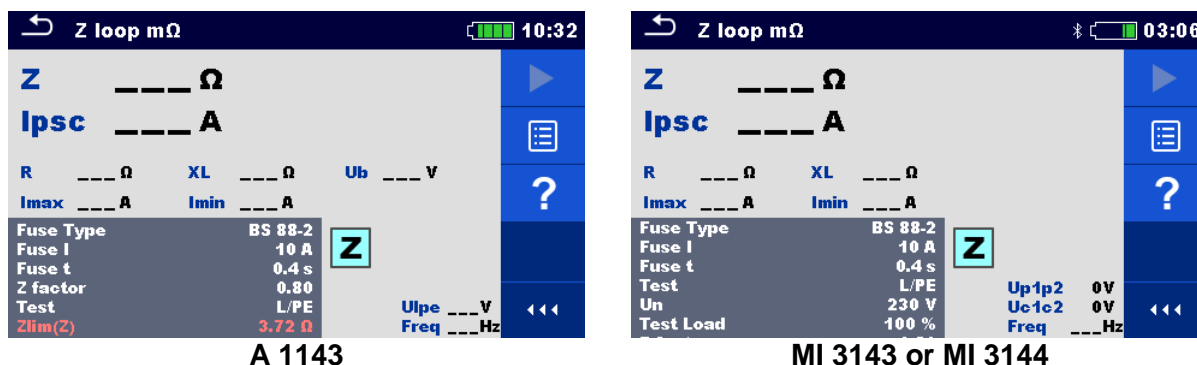

Figure 7.58: Z loop mΩ menu

Measurement parameters / limits

Fuse Type	Selection of fuse type [Off, Custom, BS 88-2, BS 88-3, BS 3036, BS 1362, B, C, D]
Fuse I	Rated current of selected fuse
Fuse t	Maximum breaking time of selected fuse
Test¹⁾	Test [-, L/PE, L1/PE, L2/PE, L3/PE]

Un²⁾	Nominal voltage [Custom, 110 V, 115 V, 127 V, 220 V, 230 V, 240 V, 290 V, 400 V]
Tolerance²⁾	MI 3143 & MI 3144: Nominal voltage tolerance [6 %, 10 %]
Test Load²⁾	MI 3143: Test Load [33.3 %, 66.6 %, 100 %] MI 3144: Test Load [16.6 %, 33.3 %, 50.0 %, 66.6 %, 83.3 %, 100 %]
Z factor	Z factor [Custom, 0.8, 1]
Average²⁾	MI 3143 & MI 3144: Average [Off, 2, 4, 6]
Zlim(Z)	Maximum loop impedance for selected fuse or custom value

- 1) The measurement doesn't depend on the setting. The parameter is meant for documentation.
2) Parameter is available only if MI 3143 or MI 3144 Euro Z instrument is selected.

Refer to **Fuse tables guide** for detailed information on fuse data.

Connection diagram

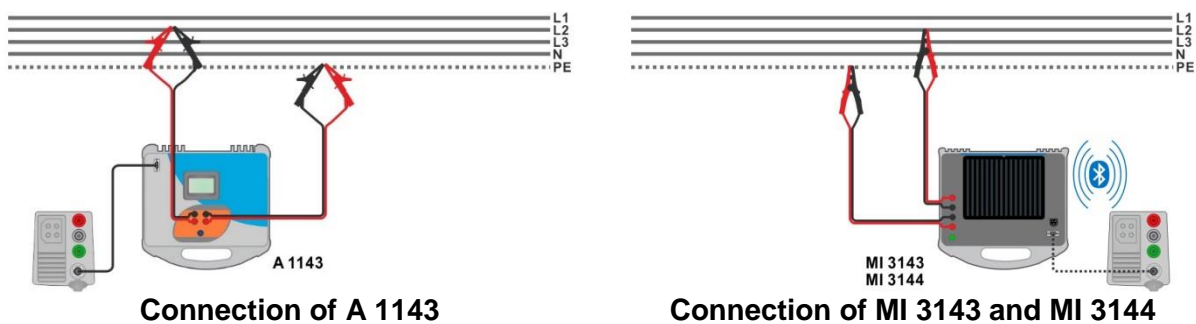

Figure 7.59: High precision loop impedance measurement – Connection of A 1143

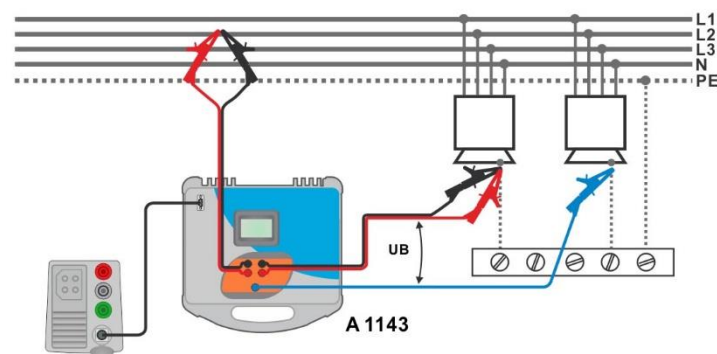

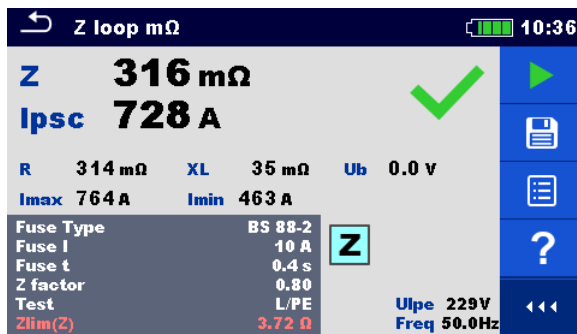

Figure 7.60: Contact voltage measurement – Connection of A 1143

Measurement procedure

- ▶ Connect MI 3155 instrument with A 1143, MI 3143 or MI 3144 Euro Z adapter / instrument via serial RS232 or pair them using Bluetooth communication. See chapter **4.6.8.1 Adapters**.
- ▶ Enter the **Z loop mΩ** function.
- ▶ Set test parameters / limits.
- ▶ Check Bluetooth communication active sign if MI 3143 or MI 3144 Euro Z instrument is connected to MI 3155 instrument via Bluetooth communication.
- ▶ Connect test leads to A 1143, MI 3143 or MI 3144 Euro Z adapter / instrument.

- › Connect test leads to the object under test, see **Figure 7.59** and **Figure 7.60**.
- › Start the measurement using  or  button.
- › Save results (optional).



Result screen using A 1143



Result screen using MI 3143 or MI 3144

Figure 7.61: Examples of high precision Loop impedance measurement result

Measurement results / sub-results

Z	Loop impedance
Ipsc	Standard prospective fault current
Imax	Maximal prospective fault current
Imin	Minimal prospective fault current
Ub	A 1143 only: Contact voltage at maximal prospective fault current (contact voltage measured against Probe S if used)
R	Resistance of loop impedance
XL	Reactance of loop impedance
Ulpe	Voltage L-PE
Freq	Frequency

Refer to **A 1143 – Euro Z 290 A**, **MI 3143 – Euro Z 440 V** and **MI 3144 – Euro Z 800 V Instruction manuals** for detailed information.

7.15 Z line – Line impedance and prospective short-circuit current

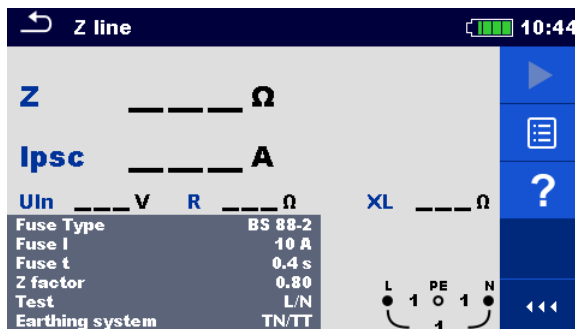

Figure 7.62: Z line measurement menu

Measurement parameters / limits

Fuse Type	Selection of fuse type [Off, Custom, BS 88-2, BS 88-3, BS 3036, BS 1362, B, C, D]
Fuse I	Rated current of selected fuse
Fuse t	Maximum breaking time of selected fuse
Z_factor	Z factor [Custom, 0.8, 1]
Test	Test [-, L/N, L/L, L1/N, L2/N, L3/N, L1/L2, L1/L3, L2/L3] ¹⁾
Earthing system	Refer to chapter 4.6.8 Settings for more information.
Zlim(Z)	Maximum line impedance for selected fuse or custom value

¹⁾ With test leads or Plug commander Z line test is measured in the same way regardless of the setting. The parameter is meant for documentation.

Refer to **Fuse tables guide** for detailed information on fuse data.

Connection diagram

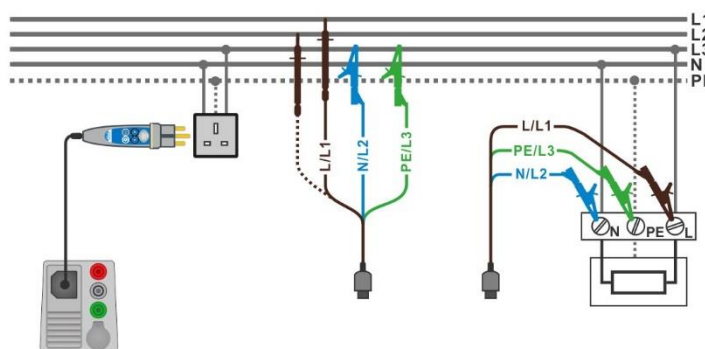

Figure 7.63: Phase-neutral or phase-phase line impedance measurement – connection of Plug commander and 3-wire test lead

Measurement procedure

- › Enter the **Z line** function.
- › Set test parameters / limits.
- › Connect test cable to the instrument.
- › Connect 3-wire test lead or Plug commander to the object under test, see **Figure 7.63**.
- › Start the measurement.
- › Save results (optional).

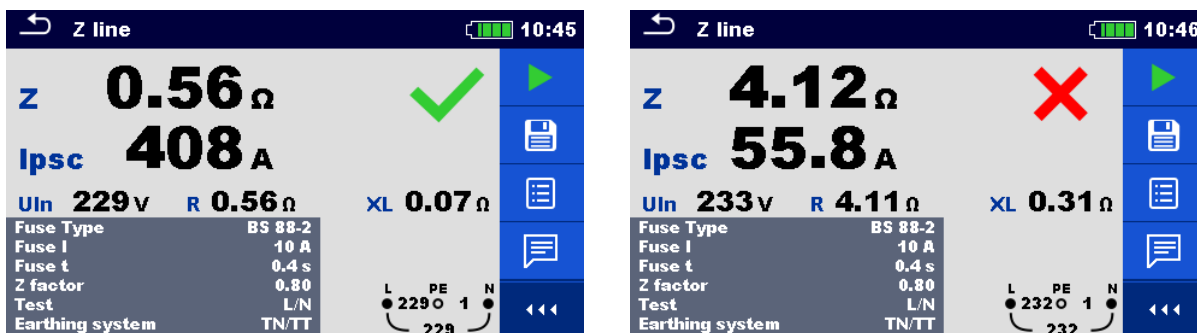

Figure 7.64: Examples of Line impedance measurement result

Measurement results / sub-results

Z	Line impedance
Ipsc	Prospective short-circuit current
Uln	Voltage measured between L and N test terminals
R	Resistance of line impedance
XL	Reactance of line impedance
Imax3p	Maximal three-phases prospective short-circuit current
Imin3p	Minimal three-phases prospective short-circuit current
Imax2p	Maximal two-phases prospective short-circuit current
Imin2p	Minimal two-phases prospective short-circuit current
Imax	Maximal single-phase prospective short-circuit current
Imin	Minimal single-phase prospective short-circuit current

Prospective short circuit current I_{PSC} is calculated as follows:

$$I_{PSC} = \frac{U_n}{Z}$$

Line impedance limit $Z_{Lim(Z)}$ for selected fuse is calculated from the following formula:

$$Z_{Lim(Z)} = Scaling_factor \times Z_{Lim}$$

where:

- Z_{Lim} Maximum loop impedance for selected fuse
- Scaling factor..... Impedance correction factor (Z factor) (see chapter **4.6.8 Settings** for more information.)
- U_n Nominal U_{L-N} or U_{L-L} voltage (see table below)

U_n	Input voltage range (L-N or L-L)
110 V	$(93 \text{ V} \leq U_{L-N} \leq 134 \text{ V})$
230 V	$(185 \text{ V} \leq U_{L-N} \leq 266 \text{ V})$
400 V	$(321 \text{ V} \leq U_{L-L} \leq 485 \text{ V})$

Table 7.8: Relation between Input voltage – $U_{L-N(L)}$ and nominal voltage – U_n used for calculation

The prospective short-circuit currents I_{Min} , I_{Min2p} , I_{Min3p} and I_{Max} , I_{Max2p} , I_{Max3p} are calculated as follows:

$I_{Min} = \frac{C_{min} U_{N(L-N)}}{Z_{(L-N)hot}}$	where	$Z_{(L-N)hot} = \sqrt{(1.5 \times R_{(L-N)})^2 + X_{(L-N)}^2}$ $C_{min} = \begin{cases} 0.95; & U_{N(L-N)} = 230 \text{ V} \pm 10 \% \\ 1.00; & \text{otherwise} \end{cases}$
$I_{Max} = \frac{C_{max} U_{N(L-N)}}{Z_{(L-N)}}$	where	$Z_{(L-N)} = \sqrt{R_{(L-N)}^2 + X_{(L-N)}^2}$ $C_{max} = \begin{cases} 1.05; & U_{N(L-N)} = 230 \text{ V} \pm 10 \% \\ 1.10; & \text{otherwise} \end{cases}$
$I_{Min2p} = \frac{C_{min} U_{N(L-L)}}{Z_{(L-L)hot}}$	where	$Z_{(L-L)hot} = \sqrt{(1.5 \times R_{(L-L)})^2 + X_{(L-L)}^2}$ $C_{min} = \begin{cases} 0.95; & U_{N(L-L)} = 400 \text{ V} \pm 10 \% \\ 1.00; & \text{otherwise} \end{cases}$
$I_{Max2p} = \frac{C_{max} U_{N(L-L)}}{Z_{(L-L)}}$	where	$Z_{(L-L)} = \sqrt{R_{(L-L)}^2 + X_{(L-L)}^2}$ $C_{max} = \begin{cases} 1.05; & U_{N(L-L)} = 400 \text{ V} \pm 10 \% \\ 1.10; & \text{otherwise} \end{cases}$
$I_{Min3p} = \frac{C_{min} \times U_{N(L-L)}}{\sqrt{3}} \frac{2}{Z_{(L-L)hot}}$	where	$Z_{(L-L)hot} = \sqrt{(1.5 \times R_{(L-L)})^2 + X_{(L-L)}^2}$ $C_{min} = \begin{cases} 0.95; & U_{N(L-L)} = 400 \text{ V} \pm 10 \% \\ 1.00; & \text{otherwise} \end{cases}$
$I_{Max3p} = \frac{C_{max} \times U_{N(L-L)}}{\sqrt{3}} \frac{2}{Z_{(L-L)}}$	where	$Z_{(L-L)} = \sqrt{R_{(L-L)}^2 + X_{(L-L)}^2}$ $C_{max} = \begin{cases} 1.05; & U_{N(L-L)} = 400 \text{ V} \pm 10 \% \\ 1.10; & \text{otherwise} \end{cases}$

7.16 Z line 4W – Line impedance and prospective short-circuit current

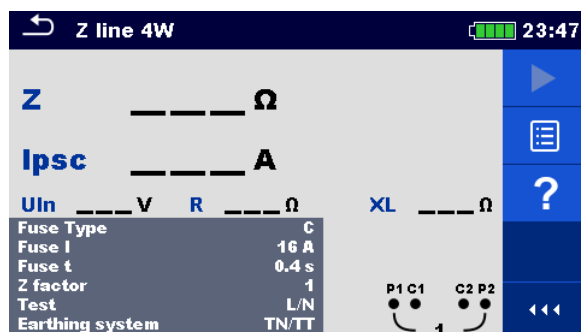

Figure 7.65: Z line 4W measurement menu

Measurement parameters / limits

Fuse Type	Selection of fuse type [Off, Custom, BS 88-2, BS 88-3, BS 3036, BS 1362, B, C, D]
Fuse I	Rated current of selected fuse
Fuse t	Maximum breaking time of selected fuse
Z_factor	Z factor [Custom, 1, 1.04]
Test	Test [-, L/N, L/L, L1/N, L2/N, L3/N, L1/L2, L1/L3, L2/L3] ¹⁾
Earthing system	Refer to chapter 4.6.8 Settings for more information.
Zlim(Z)	Maximum line impedance for selected fuse or custom value

¹⁾ With test leads or Plug commander Z line test is measured in the same way regardless of the setting. The parameter is meant for documentation.

Refer to **Fuse tables guide** for detailed information on fuse data.

Connection diagram

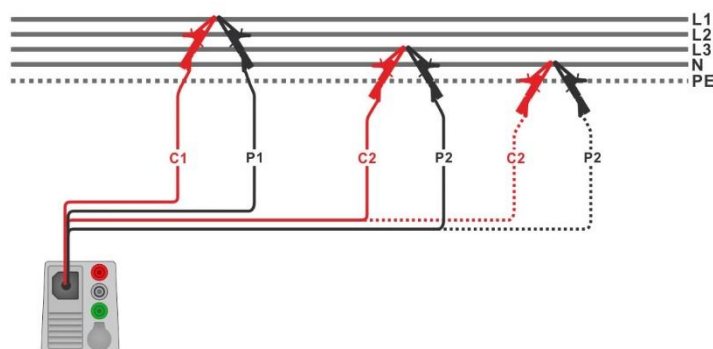

Figure 7.66: Phase-phase or phase-neutral 4-wire line impedance measurement

Measurement procedure

- › Enter the **Z line 4W** function.
- › Set test parameters / limits.
- › Connect test cable to the instrument.
- › Connect 4-wire test lead to the object under test, see **Figure 7.66**.
- › Start the measurement.

- Save results (optional).

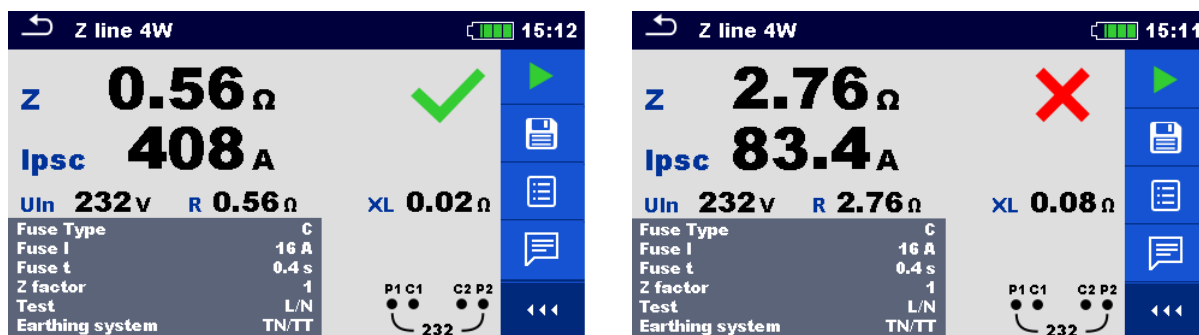

Figure 7.67: Examples of 4W line impedance measurement result

Measurement results / sub-results

Z	Line impedance
IpSC	Prospective short-circuit current
Uln	Voltage L-N
R	Resistance of line impedance
XL	Reactance of line impedance

Prospective short circuit current I_{PSC} is calculated as follows:

$$I_{PSC} = \frac{U_n}{Z}$$

Line impedance limit $Z_{Lim(Z)}$ for selected fuse is calculated from the following formula:

$$Z_{Lim(Z)} = Scaling_factor \times Z_{Lim}$$

where:

- Z_{Lim} Maximum loop impedance for selected fuse
- Scaling factor..... Impedance correction factor (Z factor) (see chapter **4.6.8 Settings** for more information.)
- U_n Nominal U_{L-N} or U_{L-L} voltage (see table below)

U_n	Input voltage range (L-N or L1-L2)
110 V	(93 V ≤ U_{L-N} < 134 V)
230 V	(185 V ≤ U_{L-N} ≤ 266 V)
400 V	(321 V < U_{L-L} ≤ 485 V)

Table 7.9: Relation between Input voltage – $U_{L-N(L)}$ and nominal voltage – U_n used for calculation

7.17 Z line mΩ – High precision line impedance and prospective short-circuit current

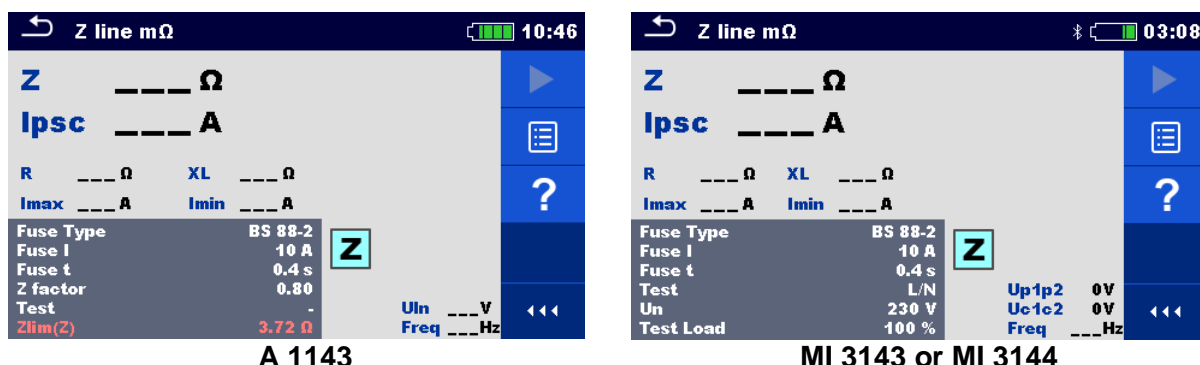

Figure 7.68: Z line mΩ menu

Measurement parameters / limits

Fuse Type	Selection of fuse type [Off, Custom, BS 88-2, BS 88-3, BS 3036, BS 1362, B, C, D]
Fuse I	Rated current of selected fuse
Fuse t	Maximum breaking time of selected fuse
Test¹⁾	Test [-, L/N, L/L, L1/N, L2/N, L3/N, L1/L2, L1/L3, L2/L3]
Un²⁾	Test=[-, L/N, L1/N, L2/N, L3/N]: Nominal voltage [Custom, 110 V, 115 V, 127 V, 220 V, 230 V, 240 V, 290 V, 400 V] Test=[L/L, L1/L2, L1/L3, L2/L3]: Nominal voltage [Custom, 190 V, 200 V, 220 V, 380 V, 400 V, 415 V, 500 V, 690 V]
Tolerance²⁾	MI 3143 & MI 3144: Nominal voltage tolerance [6 %, 10 %]
Test Load²⁾	MI 3143: Test Load [33.3 %, 66.6 %, 100 %] MI 3144: Test Load [16.6 %, 33.3 %, 50.0 %, 66.6 %, 83.3 %, 100 %]
Z factor	Z factor [Custom, 0.8, 1]
Average²⁾	MI 3143 & MI 3144: Average [Off, 2, 4, 6]
Zlim(Z)	Maximum line impedance for selected fuse or custom value

¹⁾ The measuring results (for phase – neutral or phase – phase line) are set according to the setting. The parameter is meant for documentation.

²⁾ Parameter is available only if MI 3143 or MI 3144 Euro Z instrument is selected.

Refer to **Fuse tables guide** for detailed information on fuse data.

Connection diagram

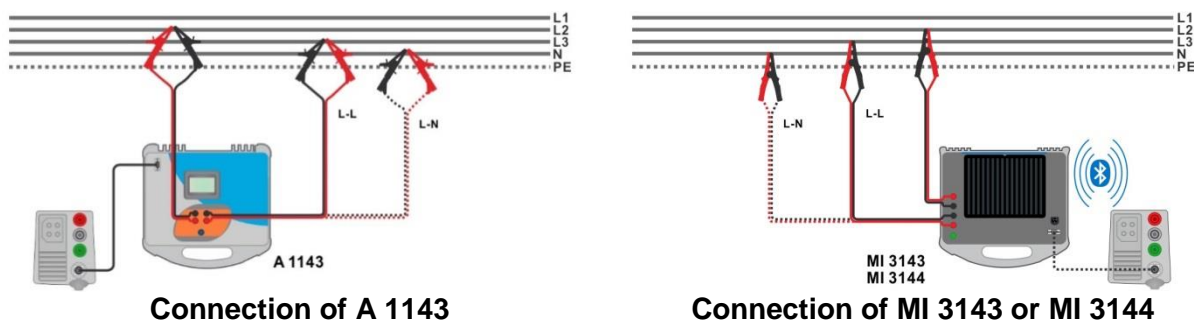

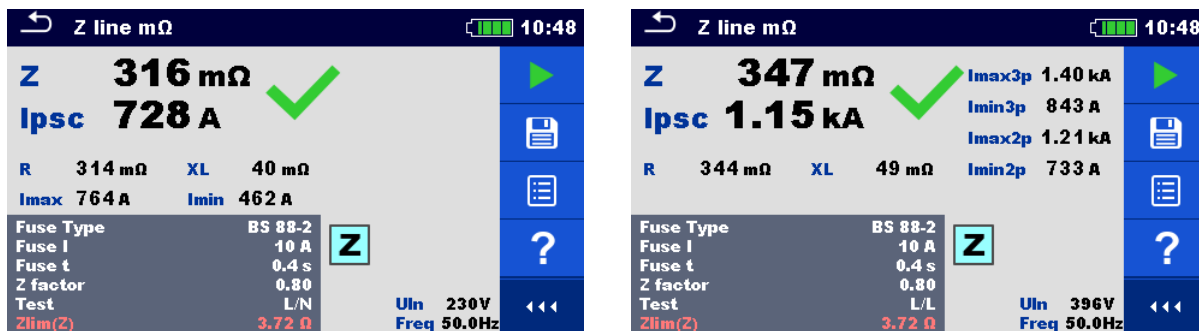

Figure 7.69: Phase-neutral or phase-phase high precision Line impedance measurement

Measurement procedure

- ▶ Connect MI 3155 instrument with A 1143, MI 3143 or MI 3144 Euro Z adapter / instrument via serial RS232 or pair them using Bluetooth communication. See chapter 4.6.8.1 Adapters.
- ▶ Enter the **Z line mΩ** function.
- ▶ Set test parameters / limits.
- ▶ Check Bluetooth communication active sign if MI 3143 or MI 3144 Euro Z instrument is connected to MI 3155 instrument via Bluetooth communication.
- ▶ Connect test leads to A 1143, MI 3143 or MI 3144 Euro Z adapter / instrument.
- ▶ Connect A 1143 – Euro Z 290 A adapter to the instrument using RS232-PS/2 cable.
- ▶ Connect test leads to the object under test, see **Figure 7.69**.
- ▶ Start the measurement using  or  button.
- ▶ Save results (optional).



Result screens using A 1143

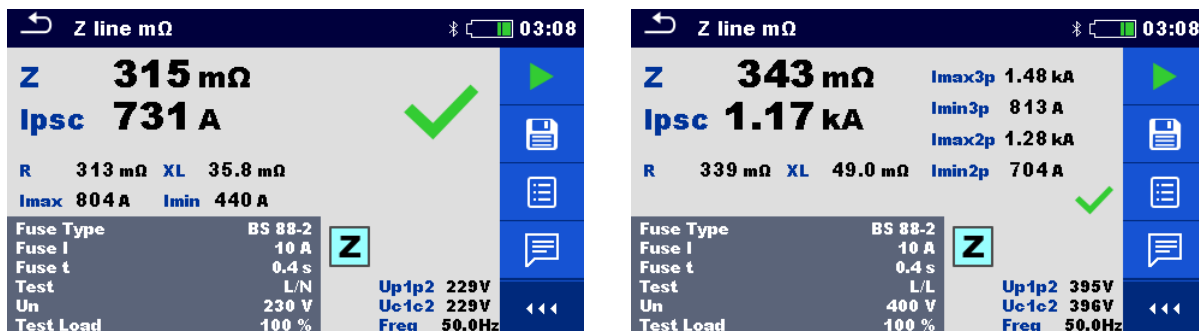

Result screens using MI 3143 or MI 3144

Figure 7.70: Examples of high precision Line impedance measurement result

Measurement results / sub-results

Z	Line impedance
Ipsc	Standard prospective short-circuit current
I_{max}	Maximal prospective short-circuit current
I_{min}	Minimal prospective short-circuit current
I_{max2p}	Maximal two-phases prospective short-circuit current
I_{min2p}	Minimal two-phases prospective short-circuit current
I_{max3p}	Maximal three-phases prospective short-circuit current
I_{min3p}	Minimal three-phases prospective short-circuit current
R	Resistance of line impedance
XL	Reactance of line impedance

Voltage monitor using A 1143:

U_{ln}	Voltage L-N or L-L
Freq	Frequency

Voltage monitor using MI 3143 or MI 3144:

U_{p1p2}	Voltage P1-P2
U_{c1c2}	Voltage C1-C2
Freq	Frequency

Refer to **A 1143 – Euro Z 290 A**, **MI 3143 – Euro Z 440 V** and **MI 3144 – Euro Z 800 V Instruction manuals** for detailed information.

7.18 High Current (MI 3143 and MI 3144)

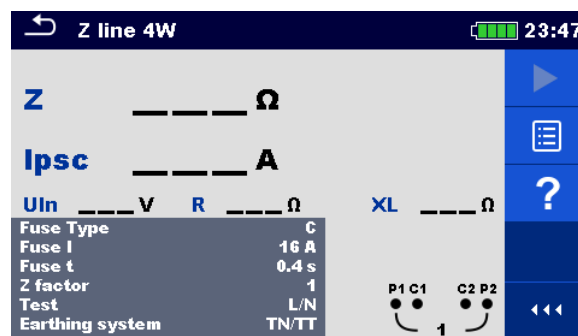

Figure 7.71: High Current menu

Measurement parameters / limits

Test Load	MI 3143: Test load [33.3 %, 66.6 %, 100 %] MI 3144: Test load [16.6 %, 33.3 %, 50.0 %, 66.6 %, 83.3 %, 100 %]
Clamp Type¹⁾	Clamp type [A 1227, A 1281, A 1609]
Clamp Range¹⁾	Range @ A 1227, A 1609 [30 A, 300 A, 3000 A] Range @ A 1281 [0.5 A, 5 A, 100 A, 1000 A]
Average	Average [Off, 2, 4, 6]
Limit (ΔR)	Limit [Off, Custom, 0.01 Ω ... 19 Ω]

¹⁾ Measurement with current clamps is supported by **MI 3144 – Euro Z 800 V** instrument only.

Connection diagram

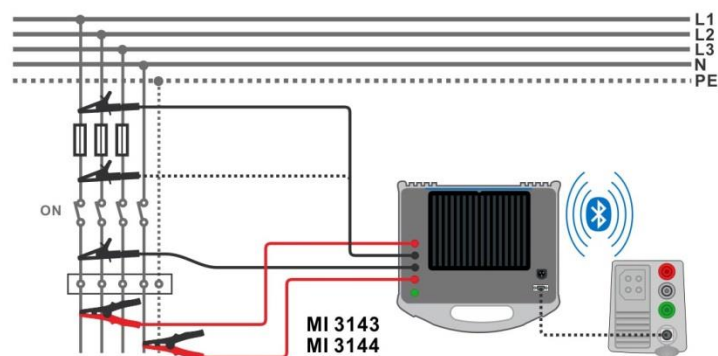



Figure 7.72: High Current resistance measurement

Measurement procedure

- › Connect MI 3155 instrument with A 1143, MI 3143 or MI 3144 Euro Z adapter / instrument via serial RS232 or pair them using Bluetooth communication. See chapter **4.6.8.1 Adapters**.
- › Enter the **High Current** function.
- › Set test parameters / limits.
- › Check Bluetooth communication active sign if MI 3143 or MI 3144 Euro Z instrument is connected to MI 3155 instrument via Bluetooth communication.
- › Connect test leads to MI 3143 or MI 3144 Euro Z instrument.
- › Connect test leads to the object under test. See **Figure 7.72**.

- Refer to **MI 3143 – Euro Z 440 V** or **MI 3144 – Euro Z 800 V Instruction manual** for detailed information.

- Start the measurement using  or  button.
- Save results (optional).

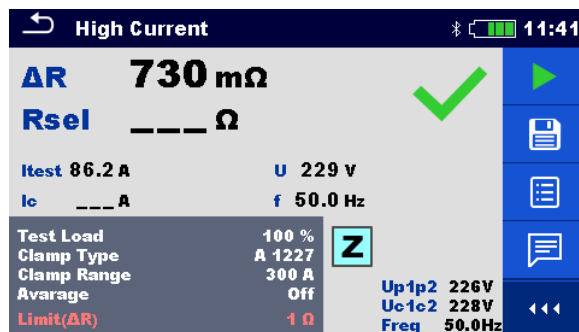

Figure 7.73: Example of High Current measurement result

Measurement results / sub-results

ΔR	Resistance
$R_{sel}^{1)}$	Resistance (calculated from Clamp current)
I_{test}	Test current
$I_c^{1)}$	Clamp current
U	Voltage
f	Frequency

¹⁾ Measurement with current clamps is supported by **MI 3144 – Euro Z 800 V** instrument only.

Voltage monitor:

Up1p2	Voltage P1-P2
Uc1c2	Voltage C1-C2
Freq	Frequency

Refer to **MI 3143 – Euro Z 440 V** and **MI 3144 – Euro Z 800 V Instruction manuals** for detailed information.

7.19 Voltage Drop

The voltage drop is calculated based on the difference of line impedance at connection points (sockets) and the line impedance at the reference point (usually the impedance at the switchboard).

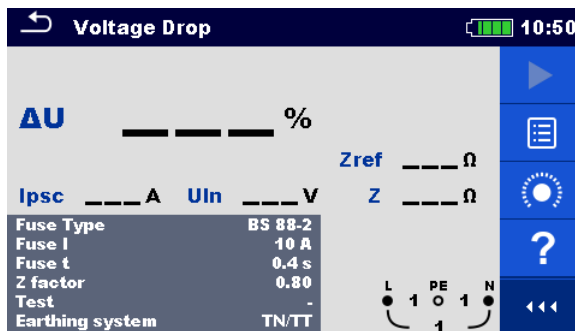

Figure 7.74: Voltage drop menu

Measurement parameters / limits

Fuse Type	Selection of fuse type [Off, Custom, BS 88-2, BS 88-3, BS 3036, BS 1362, B, C, D]
Fuse I	Rated current of selected fuse
Fuse t	Maximum breaking time of selected fuse
I (ΔU)¹⁾	Rated current for ΔU measurement (custom value)
Z_factor	Z factor [Custom, 0.8, 1]
Test²⁾	Test [-, L/N, L/L, L1/N, L2/N, L3/N, L1/L2, L1/L3, L2/L3]
Earthing system	Refer to chapter 4.6.8 Settings for more information.
Limit(ΔU)	Maximum voltage drop [Off, Custom, 3.0 % ... 9.0 %]

¹⁾ Applicable if Fuse type is set to Off or Custom

²⁾ With Plug commander Voltage Drop test is measured in the same way regardless of the setting. The parameter is meant for documentation.

Refer to **Fuse tables guide** for detailed information on fuse data.

Connection diagram

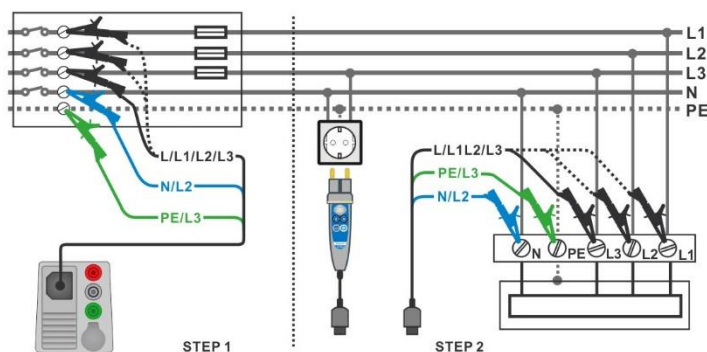



Figure 7.75: Voltage drop measurement – connection of Plug commander and 3-wire test lead

Measurement procedure

STEP 1: Measuring the impedance Zref at origin

- › Enter the **Voltage Drop** function.
- › Set test parameters / limits.
- › Connect test cable to the instrument.
- › Connect 3-wire test lead to the origin of electrical installation, see **Figure 7.75**.
- › Touch or select the  icon to initiate Zref measurement.
- › Press the  button to measure Zref.

STEP 2: Measuring the Voltage drop

- › Enter the **Voltage Drop** function.
- › Set test parameters / limits.
- › Connect test cable to the instrument.
- › Connect 3-wire test lead or Plug commander to the tested points, see **Figure 7.75**.
- › Start the measurement.
- › Save results (optional).

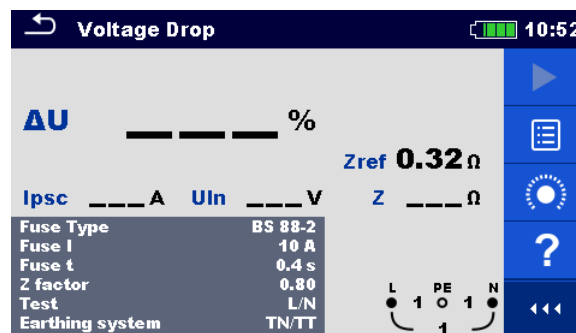

Figure 7.76: Example of Zref measurement result (Step 1)

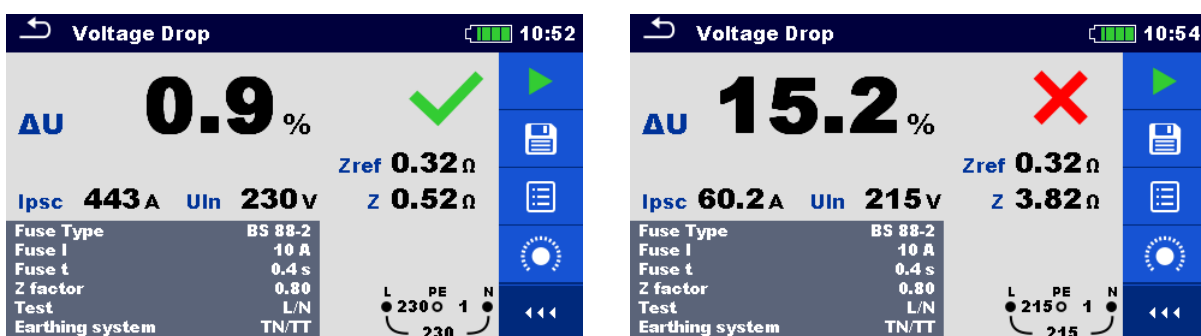

Figure 7.77: Examples of Voltage drop measurement result (Step 2)

Measurement results / sub-results

ΔU	Voltage drop
I_{psc}	Prospective short-circuit current
U_{ln}	Voltage L-N
Z_{ref}	Reference line impedance
Z	Line impedance

Voltage drop is calculated as follows:

$$\Delta U[\%] = \frac{(Z - Z_{REF}) \cdot I_N}{U_N} \cdot 100$$

where:

ΔU	Calculated Voltage drop
Z_{ref}	Impedance at reference point (at origin)
Z	Impedance at test point
U_n	Nominal voltage
I_n	Rated current of selected fuse (Fuse I) or custom value I (ΔU)

U_n	Input voltage range (L-N or L-L)
110 V	$(93 \text{ V} \leq U_{L-N} \leq 134 \text{ V})$
230 V	$(185 \text{ V} \leq U_{L-N} \leq 266 \text{ V})$
400 V	$(321 \text{ V} \leq U_{L-L} \leq 485 \text{ V})$

Table 7.10: Relation between Input voltage – $U_{L-N(L)}$ and nominal voltage – U_n used for calculation

7.20 U touch – Touch voltage (MI 3143 and MI 3144)

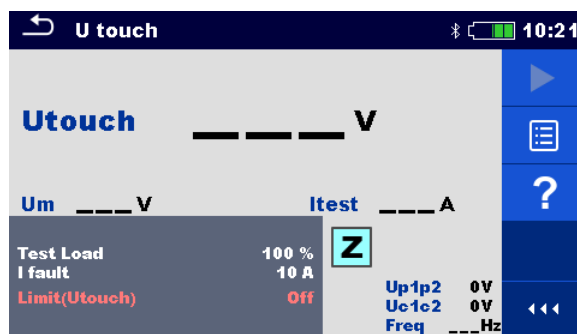

Figure 7.78: Touch voltage menu

Measurement parameters / limits

Test Load	MI 3143: Test load [33.3 %, 66.6 %, 100 %] MI 3144: Test load [16.6 %, 33.3 %, 50.0 %, 66.6 %, 83.3 %, 100 %]
I fault	Fault current [Custom, 10 A ... 200 kA]
Limit(Utouch)	Limit [Off, Custom, 25 V, 50 V]

Connection diagram

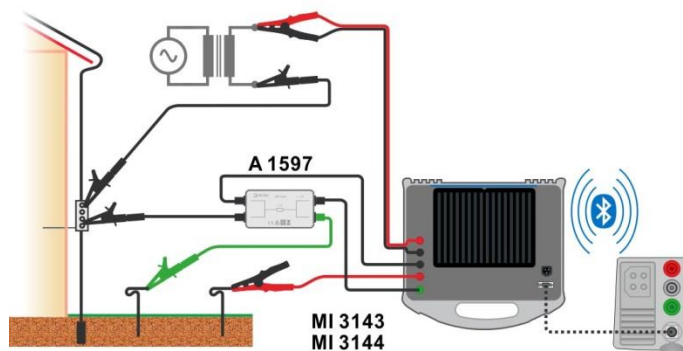

Figure 7.79: Touch voltage measurement – Connection of MI 3143 or MI 3144

Refer to *MI 3143 – Euro Z 440 V* and *MI 3144 – Euro Z 800 V Instruction manual* for detailed information.

Measurement procedure

- ▶ Connect MI 3155 instrument with MI 3143 or MI 3144 Euro Z instrument via serial RS232 or pair them using Bluetooth communication. See chapter **4.6.8.1 Adapters**.
- ▶ Enter the **U touch** function.
- ▶ Set test parameters / limits.
- ▶ Check Bluetooth communication active sign if MI 3143 or MI 3144 Euro Z instrument is connected to MI 3155 instrument via Bluetooth communication.
- ▶ Connect test leads and A 1597 adapter to MI 3143 or MI 3144 Euro Z instrument.
- ▶ Connect test leads to the object under test.
Refer to *MI 3143 Euro Z 440 V* or *MI 3144 Euro Z 800 V Instruction manual* for detailed information.
- ▶ Start the measurement using  or  button.

- Save results (optional).

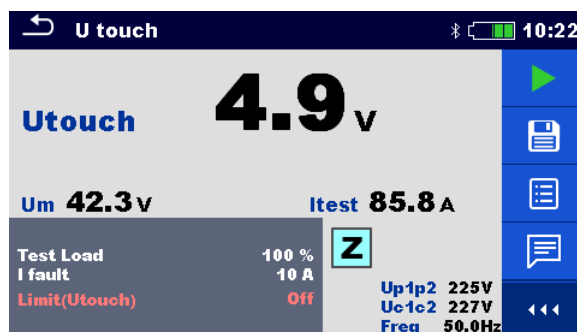

Figure 7.80: Example of Touch voltage measurement result

Measurement results / sub-results

Utouch	Calculated touch voltage
Um	Measured voltage drop
Itest	Test current

Voltage monitor:

Up1p2	Voltage P1-P2
Uc1c2	Voltage C1-C2
Freq	Frequency

Refer to *MI 3143 Euro Z 440 V* and *MI 3144 Euro Z 800 V Instruction manuals* for detailed information.

7.21 Z auto - Auto test sequence for fast line and loop testing

Tests / measurements implemented in Z auto test sequence

Voltage
Z line
Voltage Drop
Zs rcd
Uc

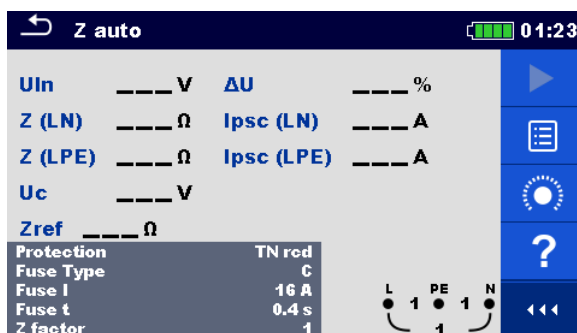

Figure 7.81: Z auto menu

Measurement parameters / limits

Protection	Protection type [TN, TNrcd, TTrcd]
Fuse type	Selection of fuse type [Off, Custom, BS 88-2, BS 88-3, BS 3036, BS 1362, B, C, D]
Fuse I	Rated current of selected fuse
Fuse t	Maximum breaking time of selected fuse
I (ΔU) ¹⁾	Rated current for ΔU measurement (custom value)
Z_factor	Z factor [Custom, 0.8, 1]
RCD Type	RCD type [AC, A, F, B, B+]
I ΔN	Rated RCD residual current sensitivity [10 mA, 15 mA, 30 mA, 100 mA, 300 mA, 500 mA, 1000 mA]
Selectivity	Characteristic [G, S]
Phase	Selection of test [-, L1, L2, L3] ²⁾
I test	Test current [Standard, Low]
Limit(ΔU)	Maximum voltage drop [Off, Custom, 3.0 % ... 9.0 %]
Zlim(Z (LN), Z (LPE)) ³⁾	Maximum line/loop impedance for selected fuse or custom value
Limit Uc	Conventional touch voltage limit [Custom, 12 V, 25 V, 50 V]

¹⁾ Applicable if Fuse type is set to Off or Custom.

²⁾ With Plug commander Z auto test is measured in the same way regardless of the setting. The parameter is meant for documentation.

³⁾ Z (LPE) is considered if Protection is set to TNrcd. Z (LN) is always considered.

Refer to **Fuse tables guide** for detailed information on fuse data.

Connection diagram

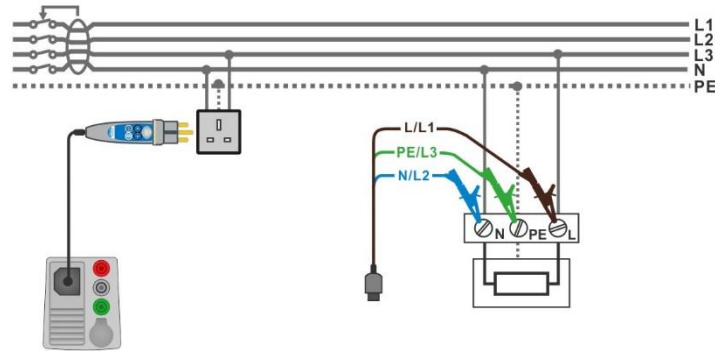

Figure 7.82: Z auto measurement

Measurement procedure

- › Enter the **Z auto** function.
- › Set test parameters / limits.
- › Measure the impedance Z_{ref} at origin (optional), see chapter **7.19 Voltage Drop**.
- › Connect test cable to the instrument.
- › Connect 3-wire test lead or Plug commander to the object under test, see **Figure 7.82**.
- › Start the Auto test.
- › Save results (optional).



Figure 7.83: Examples of Z auto measurement results

Measurement results / sub-results

U_{In}	Voltage between phase and neutral conductors
ΔU	Voltage drop
Z (LN)	Line impedance
Z (LPE)	Loop impedance
Z_{ref}	Reference line impedance
I_{psc} (LN)	Prospective short-circuit current
I_{psc} (LPE)	Prospective fault current
U_c	Contact voltage

7.22 R line mΩ – DC resistance measurement (MI 3144)

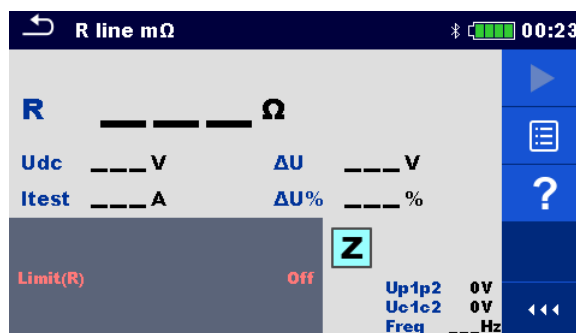

Figure 7.84: R line mΩ menu



Measurement parameters / limits

Limit (R)	Limit [Off, Custom, 0.01 Ω ... 19 Ω]
-----------	--------------------------------------

Connection diagram

Refer to *MI 3144 – Euro Z 800 V Instruction manual* for detailed information.

Measurement procedure

- › Connect MI 3155 instrument with MI 3144 Euro Z 800 V instrument via serial RS232 or pair them using Bluetooth communication. See chapter **4.6.8.1 Adapters**.
- › Enter the **R line mΩ** function.
- › Set test parameters / limits.
- › Check Bluetooth communication active sign if MI 3144 Euro Z 800 V instrument is connected to MI 3155 instrument via Bluetooth communication.
- › Connect test leads to MI 3144 Euro Z 800 V instrument.
- › Connect test leads to the object under test.
Refer to *MI 3144 Euro Z 800 V Instruction manual* for detailed information.
- › Start the measurement using  or  button.
- › Save results (optional).

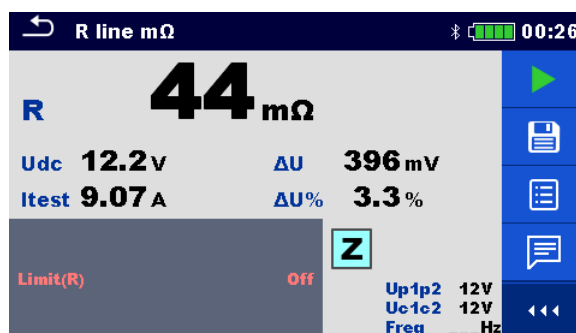

Figure 7.85: Example of R line mΩ measurement result

Measurement results / sub-results

R	Line resistance
I_{test}	Test current
U_{dc}	Voltage
ΔU	Voltage drop
ΔU%	Voltage drop in percentage

Voltage monitor:

Up1p2	Voltage P1-P2
Uc1c2	Voltage C1-C2
Freq	Frequency

Refer to *MI 3144 Euro Z 800 V Instruction manual* for detailed information.

7.23 ELR Current Injection Test (MI 3144)

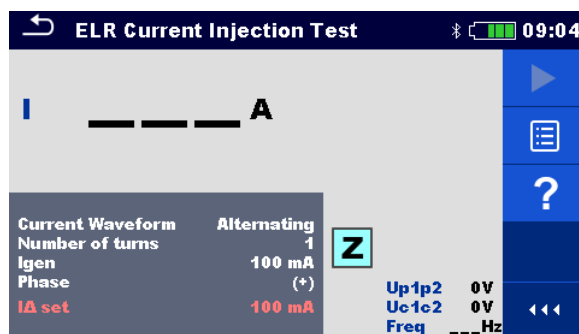

Figure 7.86: ELR Current Injection Test menu

Measurement parameters / limits

Current Waveform	Current waveform [Alternating, Pulsating, DC]
Number of turns	Number of turns [1 ... 10]
I gen	Current [3 mA, 5 mA, 6 mA, 10 mA, 15 mA, 30 mA, 50 mA, 100 mA, 150 mA, 250 mA, 300 mA, 500 mA]
Phase	Phase [(+), (-)]
IΔ set	Current limit for selected generated current and number of turns.

Connection diagram

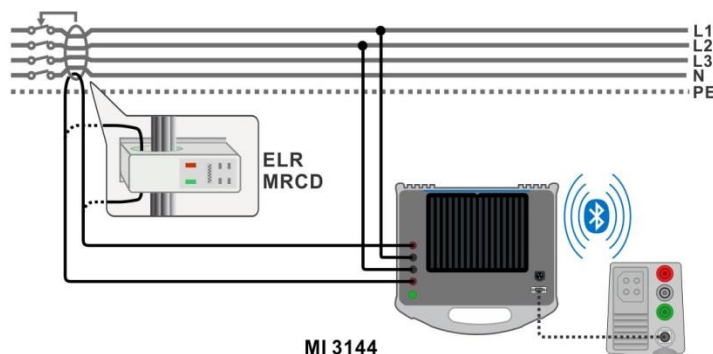







Figure 7.87: ELR Current Injection Test / Combination Time Test connection

Refer to *MI 3144 Euro Z 800 V Instruction manual* for detailed information.

Measurement procedure

- ▶ Connect MI 3155 instrument with MI 3144 Euro Z 800 V instrument via serial RS232 or pair them using Bluetooth communication. See chapter **4.6.8.1 Adapters**.
- ▶ Enter the **ELR Current Injection Test** function.
- ▶ Set test parameters / limits.
- ▶ Check Bluetooth communication active sign if MI 3144 Euro Z 800 V instrument is connected to MI 3155 instrument via Bluetooth communication.
- ▶ Connect test leads to MI 3144 Euro Z 800 V instrument.
- ▶ Connect test leads to the object under test. See **Figure 7.87**.

Refer to **MI 3144 Euro Z 800 V Instruction manual** for detailed information.

- › Start the measurement using  or  button.
- › Use  to select PASS / FAIL / NO STATUS indication.
- › Press  or the  key to confirm selection and complete the measurement.
- › Save results (optional).

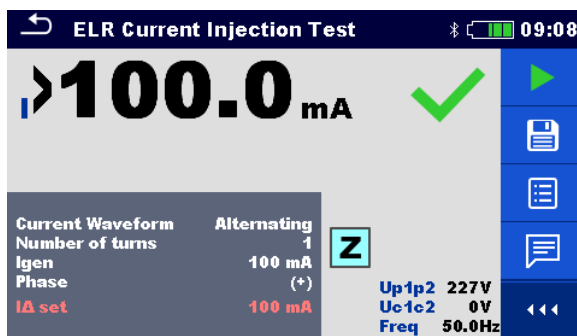

Figure 7.88: Examples of high precision Line impedance measurement result

Measurement result

I	Current
Voltage monitor:	
Up1p2	Voltage P1-P2
Uc1c2	Voltage C1-C2
Freq	Frequency

Refer to **MI 3144 Euro Z 800 V Instruction manual** for detailed information.

7.24 ELR Combination Time Test (MI 3144)

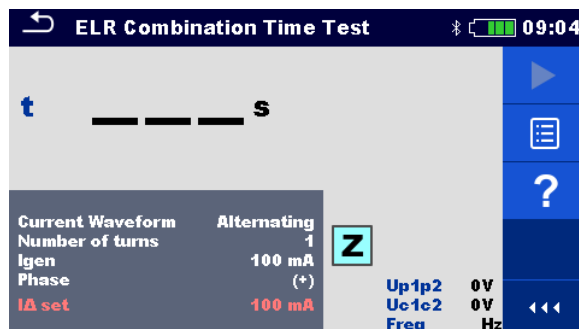

Figure 7.89: ELR Combination Time Test menu

Measurement parameters / limits





Current Waveform	Current waveform [Alternating, Pulsating, DC]
Number of turns	Number of turns [1 ... 10]
I gen	Current [3 mA, 5 mA, 6 mA, 10 mA, 15 mA, 30 mA, 50 mA, 100 mA, 150 mA, 250 mA, 300 mA, 500 mA]
Phase	Phase [(+), (-)]
Test duration	Duration [0.3 s, 0.5 s, 1 s, 2 s, 5 s, 10 s, 20 s]
IΔ set	Current limit for selected generated current and number of turns.

Connection diagram

See **Figure 7.87**.

Refer to **MI 3144 Euro Z 800 V Instruction manual** for detailed information.

Measurement procedure

- › Connect MI 3155 instrument with MI 3144 Euro Z 800 V instrument via serial RS232 or pair them using Bluetooth communication. See chapter **4.6.8.1 Adapters**.
- › Enter the **ELR Combination Time Test** function.
- › Set test parameters / limits.
- › Check Bluetooth communication active sign if MI 3144 Euro Z 800 V instrument is connected to MI 3155 instrument via Bluetooth communication.
- › Connect test leads to MI 3144 Euro Z 800 V instrument.
- › Connect test leads to the object under test. See **Figure 7.87**. Refer to **MI 3144 Euro Z 800 V Instruction manual** for detailed information.
- › Start the measurement using  or  button.
- › Use  to select PASS / FAIL / NO STATUS indication.
- › Press  or the  key to confirm selection and complete the measurement.
- › Save results (optional).

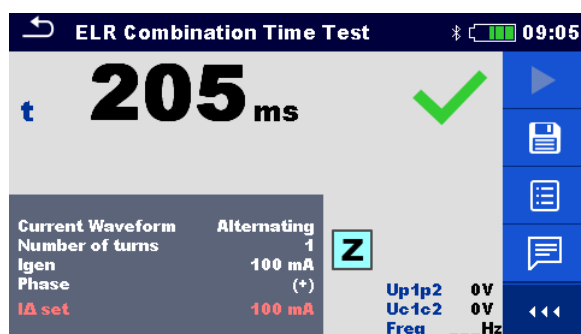

Figure 7.90: Example of ELR Combination Time Test result

Measurement result

t	Time
---	------

Voltage monitor:

Up1p2	Voltage P1-P2
Uc1c2	Voltage C1-C2
Freq	Frequency

Refer to *MI 3144 Euro Z 800 V Instruction manual* for detailed information.

7.25 EVSE Diagnostic Test (A 1632)

EVSE Diagnostic Test should be performed with A 1632 eMobility Analyser connected with MI 3155 instrument via Bluetooth communication.

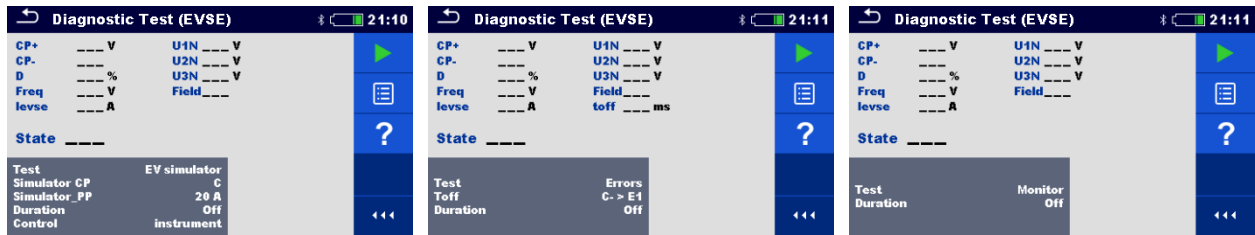

Figure 7.91: Diagnostic Test (EVSE) start screens – EV simulator, Errors and Monitor

Measurement parameters / limits

With selection of the Test parameter on the start screen, three diagnostic sub-tests can be set.

Test	Test [EV simulator, Monitor, Errors]
	<i>EV simulator</i> - Simulation of Electrical Vehicle
	<i>Monitor</i> - Monitoring of EVSE – EV interconnection and signalling
	<i>Errors</i> - Simulation of CP Errors
Toff	Simulated CP errors [C->E1, C->E2, C->E3, D->E1, D->E2, D->E3]
Simulator CP	CP (control pilot) state setting [nc, A, B, C, D, E1, E2, E3]
Simulator PP	PP (proximity pilot) state setting [nc, 13 A, 20 A, 32 A, 63 A, 80 A]
Duration	Test duration [Off, 2 s, 3 s, 5 s, 10 s, 30 s, 60 s, 90 s, 120 s, 180 s]
Control	Analyser control [instrument, manual (A 1632)]

Connection diagrams

Refer to **A 1632 – eMobility Analyzer Instruction manual** for detailed information.

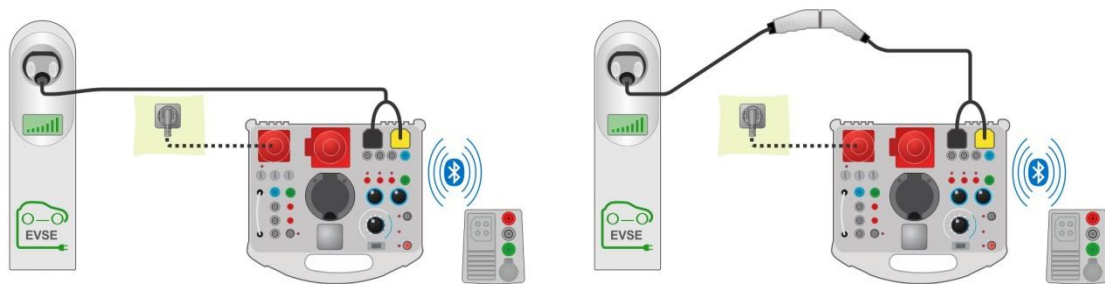

Figure 7.92: Diagnostic test - EV simulator and Errors sub-tests - connection to EVSE

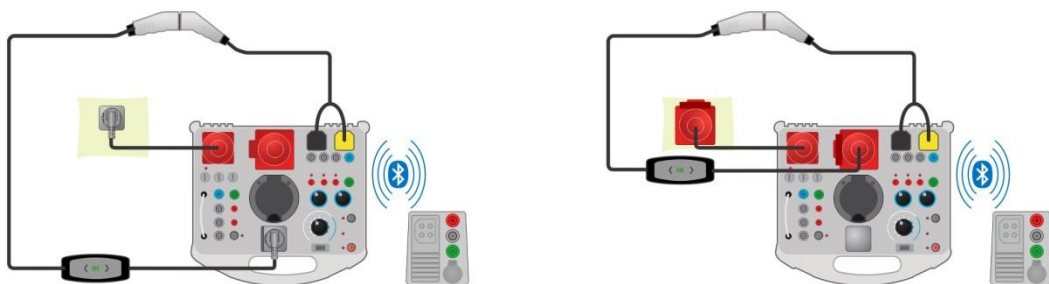

Figure 7.93: Diagnostic test - EV simulator and Errors sub-tests - connection to Mode 2 charging cable powered from Analyser

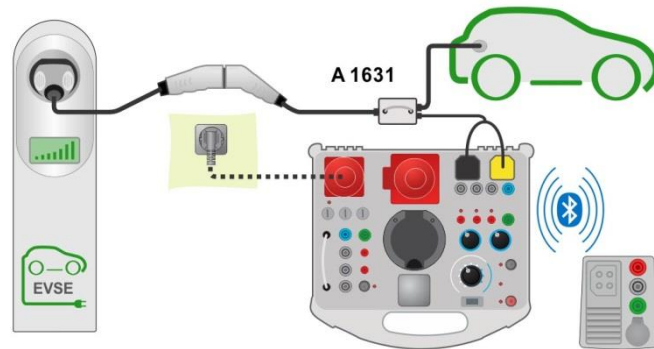



Figure 7.94: Diagnostic test (EVSE) - Monitor sub-test - connection to EVSE or charging cable

Diagnostic test procedure

- › Pair and connect MI 3155 with A 1632 eMobility Analyzer instrument via Bluetooth communication. See chapter **4.6.8.1 Adapters**.
- › Enter the **Diagnostic test (EVSE)** function.
- › Set test parameters / limits.
- › Check Bluetooth communication active sign if A 1632 eMobility Analyzer is connected to MI 3155 instrument via Bluetooth communication.
- › Connect the charging cable / station to A 1632 eMobility Analyzer adapter. See **Figure 7.92, Figure 7.93** and **Figure 7.94**. Refer to **A 1632 eMobility Analyzer Instruction manual** for detailed information.
- › Start the measurement using  or  button.
- › Manually apply status (optional).
- › Save results (optional).

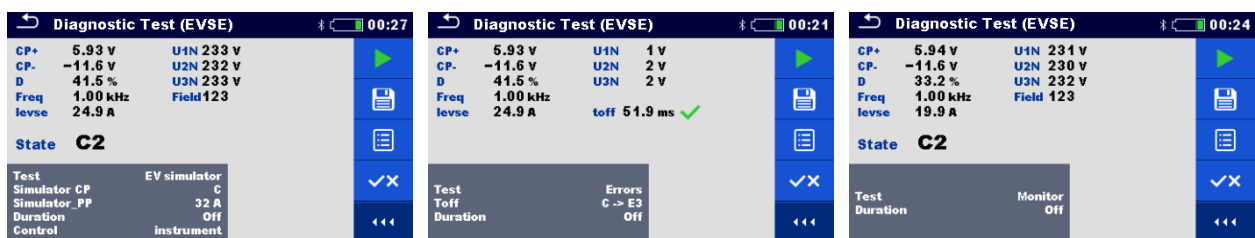

Figure 7.95: Examples of Diagnostic Test (EVSE) measurement results – EV simulator, Errors and Monitor

Measurement results / sub-results

CP+	Maximal value of CP (control pilot) signal
CP-	Minimal value of CP (control pilot) signal
D	Duty cycle of CP (control pilot) signal
Freq	Frequency of CP (control pilot) signal
levse	Charging current available by charging cable / EVSE
U1N	Voltage UL1-N on the output of charging cable / EVSE
U2N	Voltage UL2-N on the output of charging cable / EVSE
U3N	Voltage UL3-N on the output of charging cable / EVSE
Field	1.2.3 – correct connection – CW rotation sequence 3.2.1 – invalid connection – CCW rotation sequence

toff	Disconnection time of charging cable / EVSE
State	System state

Refer to *A 1632 eMobility Analyzer Instruction manual* for detailed information.

7.26 Earth – Earth resistance (3-wire test)

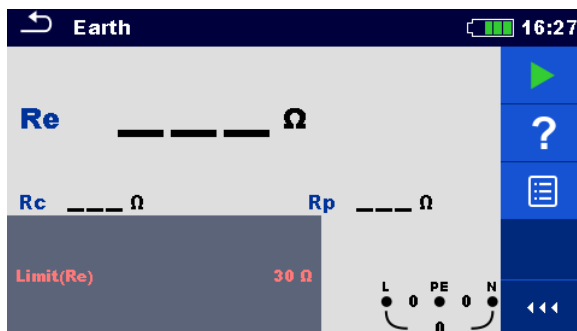

Figure 7.96: Earth menu

Measurement parameters / limits

Limit(Re) Maximum resistance [Off, Custom, 1 Ω ... 5 kΩ]

Connection diagrams

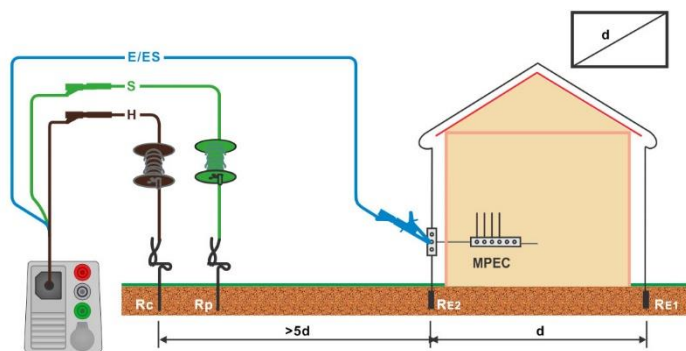

Figure 7.97: Resistance to earth, measurement of main installation earthing and lighting protection system

Measurement procedure

- › Enter the **Earth** function.
- › Set test parameters / limits.
- › Connect test cable to the instrument.
- › Connect 3-wire test lead to the object under test, see **Figure 7.97**.
- › Start the measurement.
- › Save results (optional).

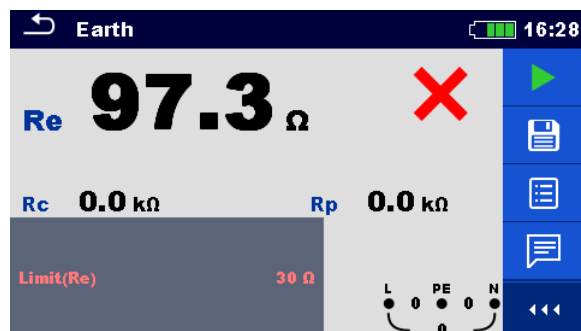
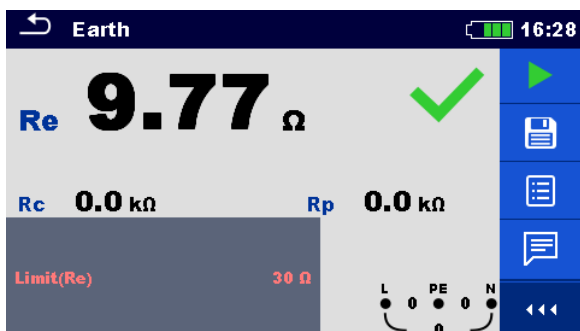

Figure 7.98: Examples of Earth resistance measurement result

Measurement results / sub-results

Re	Earth resistance
Rc	Resistance of H (current) probe
Rp	Resistance of S (potential) probe

7.27 Earth 2 clamp – Contactless earthing resistance measurement (with two current clamps)

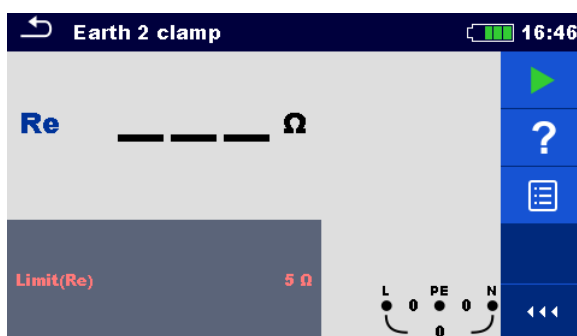

Figure 7.99: Earth 2 clamps menu

Measurement parameters / limits

Limit(Re)	Maximum resistance [Off, Custom, 1 Ω ... 30 Ω]
------------------	--

Connection diagram

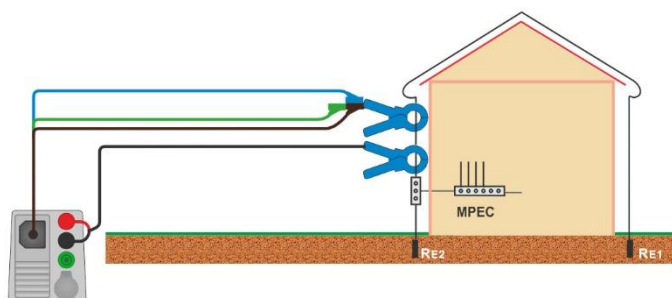

Figure 7.100: Contactless earthing resistance measurement

Measurement procedure

- › Enter the **Earth 2 clamp** function.
- › Set test parameters / limits.
- › Connect test cable and clamps to the instrument.
- › Clamp on object under test, see **Figure 7.100**.
- › Start the continuous measurement.
- › Stop the measurement.
- › Save results (optional).

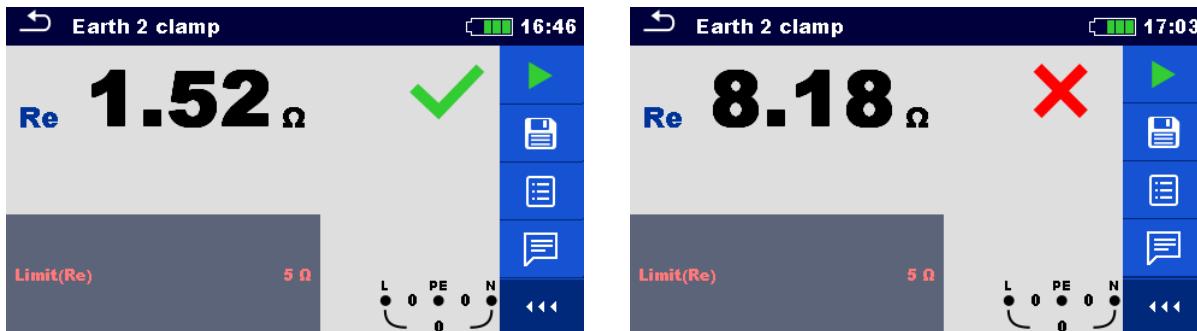

Figure 7.101: Examples of Contactless earthing resistance measurement result

Measurement results / sub-results

Re	Earth resistance
----	------------------

7.28 Ro – Specific earth resistance

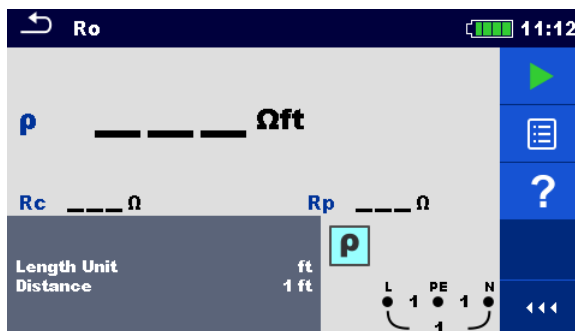

Figure 7.102: Earth Ro menu

Measurement parameters / limits

Length Unit	Length unit [m, ft]
Distance	Distance between probes [Custom, 0.1 m ... 29.9 m] or 1 ft ... 100 ft]

Connection diagram

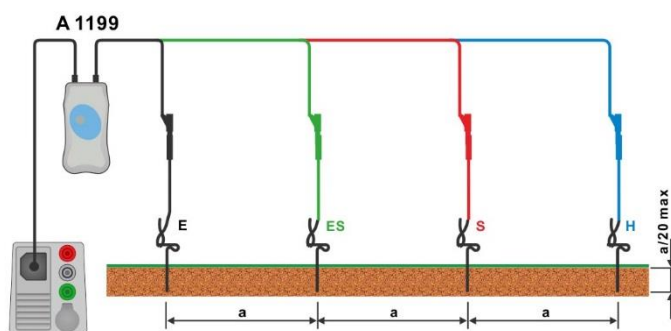

Figure 7.103: Specific earth resistance measurement

Measurement procedure

- › Enter the **Ro** function.
- › Set test parameters / limits.
- › Connect A 1199 adapter to the instrument.
- › Connect test leads to earth probes, see **Figure 7.103**.
- › Start the measurement.
- › Save results (optional).



Figure 7.104: Example of Specific earth resistance measurement result

Measurement results / sub-results

ρ	Specific earth resistance
Rc	Resistance of H, E (current) probe
Rp	Resistance of S, ES (potential) probe

7.29 Power

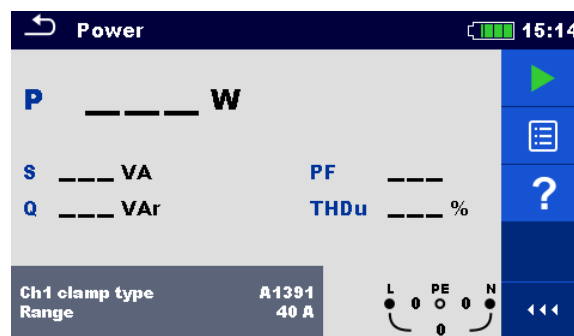

Figure 7.105: Power menu

Measurement parameters / limits

Ch1 clamp type	Current clamp adapter [A1018, A1019, A1391]
Range	Range for selected current clamp adapter
	A1018 [20 A]
	A1019 [20 A]
	A1391 [40 A, 300 A]

Connection diagram

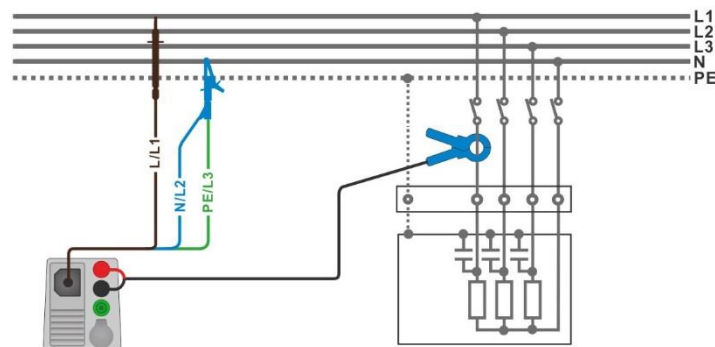

Figure 7.106: Power measurement

Measurement procedure

- › Enter the **Power** function.
- › Set parameters / limits.
- › Connect the 3-wire test lead and current clamp to the instrument.
- › Connect the 3-wire test lead and current clamp to the item to be tested (see **Figure 7.106**).
- › Start the continuous measurement.
- › Stop the measurement.
- › Save results (optional).

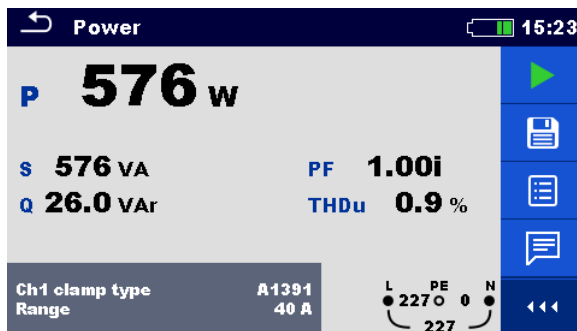

Figure 7.107: Example of Power measurement result

Measurement results / sub-results

P	Active power
S	Apparent power
Q	Reactive power (capacitive or inductive)
PF	Power factor (capacitive or inductive)
THDu	Voltage total harmonic distortion

7.30 Harmonics

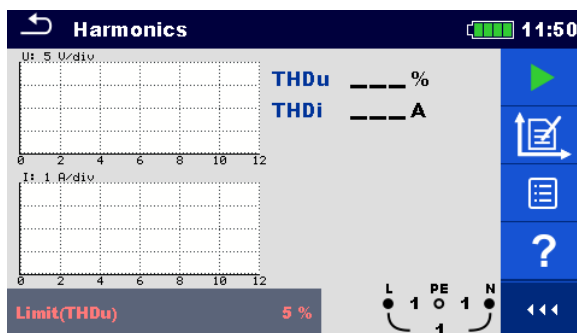

Figure 7.108: Harmonics menu

Measurement parameters / limits

Ch1 clamp type	Current clamp adapter [A1018, A1019, A1391]
Range	Range for selected current clamp adapter A1018 [20 A] A1019 [20 A] A1391 [40 A, 300 A]
Limit(THDu)	Max. THD of voltage [Off, Custom, 3 % ... 10 %]

Connection diagram

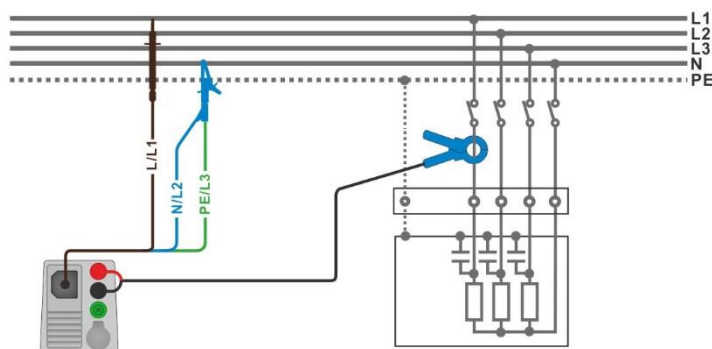

Figure 7.109: Harmonics measurement

Measurement procedure

- ▶ Enter the **Harmonics** function.
- ▶ Set parameters / limits.
- ▶ Connect 3-wire test lead and current clamp to the instrument.
- ▶ Connect the 3-wire test lead and current clamp to the item to be tested, see **Figure 7.109**.
- ▶ Start the continuous measurement.
- ▶ Stop the measurement.
- ▶ Save results (optional).

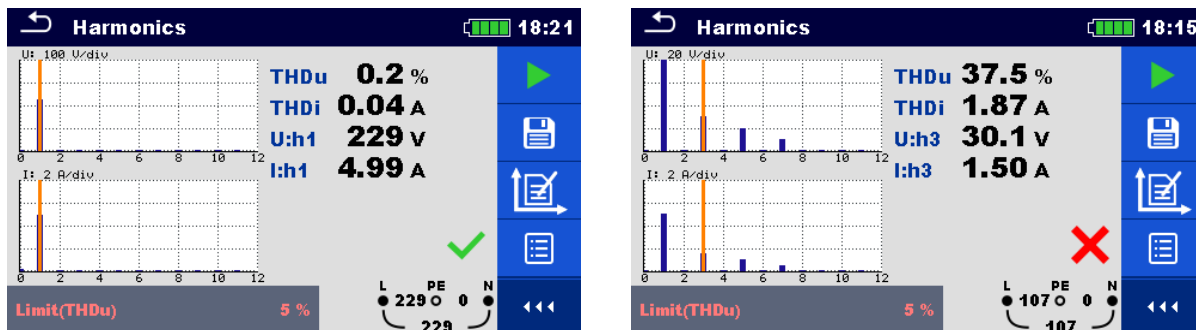

Figure 7.110: Examples of Harmonics measurement results

Measurement results / sub-results

U:h(i)	TRMS voltage of selected harmonic [h0 ... h11]
I:h(i)	TRMS current of selected harmonic [h0 ... h11]
THDu	Voltage total harmonic distortion
THDi	Current total harmonic distortion

7.31 Currents

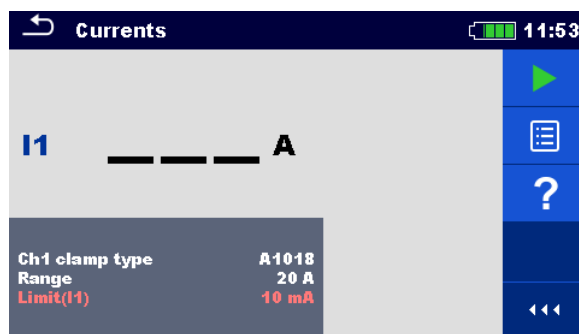

Figure 7.111: Current menu

Measurement parameters / limits

Ch1 clamp type	Current clamp adapter [A1018, A1019, A1391]
Range	Range for selected current clamp adapter A1018 [20 A] A1019 [20 A] A1391 [40 A, 300 A]
Limit(I1)	Max. PE leakage or load current [Off, Custom, 0.1 mA ... 100 mA]

Connection diagram

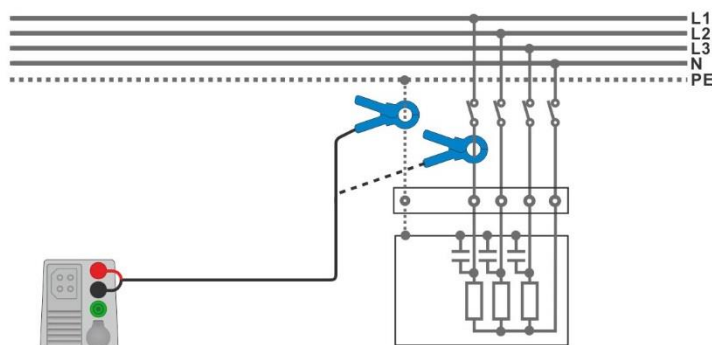

Figure 7.112: PE leakage and load current measurements

Measurement procedure

- › Enter the **Currents** function.
- › Set parameters / limits.
- › Connect the current clamp to the instrument.
- › Connect the clamp to the object under test, see **Figure 7.112**.
- › Start the continuous measurement.
- › Stop the measurement.
- › Save results (optional).

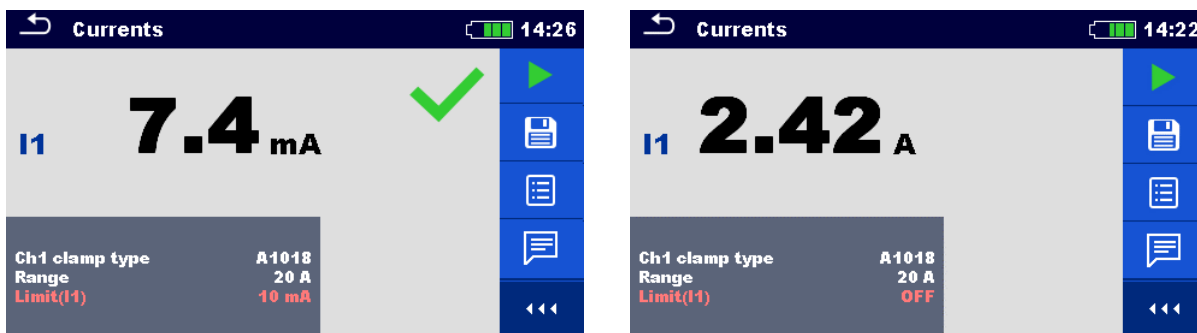

Figure 7.113: Examples of Current measurement result

Measurement results / sub-results

I1 PE leakage or load current

7.32 Current Clamp Meter (MI 3144)

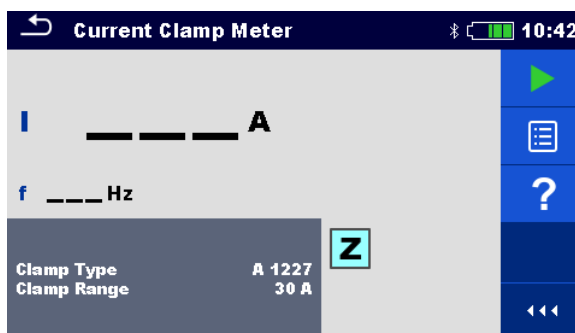

Figure 7.114: Current Clamp Meter menu

Measurement parameters / limits

Clamp Type	Clamp type [A 1227, A 1281, A 1609]
Clamp Range	Range Clamp type A 1227, A 1609: [30 A, 300 A, 3000 A] Clamp type A 1281: [0.5 A, 5 A, 100 A, 1000 A]

Connection diagram

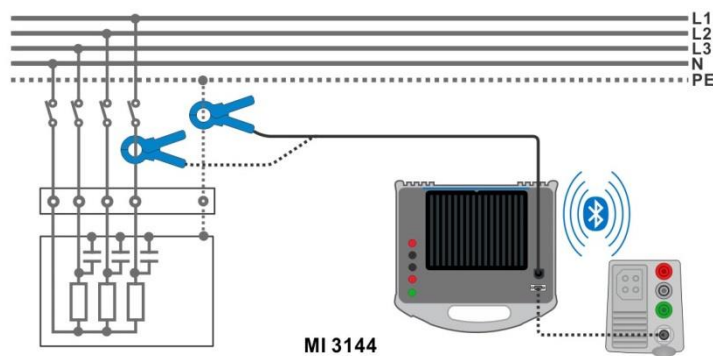



Figure 7.115: Current Clamp Meter measurement

Refer to *MI 3144 Euro Z 800 V Instruction manual* for detailed information.

Measurement procedure

- › Connect MI 3155 instrument with MI 3144 Euro Z instrument via serial RS232 or pair them using Bluetooth communication. See chapter **4.6.8.1 Adapters**.
- › Enter the **Current Clamp Meter** function.
- › Set test parameters / limits.
- › Check Bluetooth communication active sign if MI 3144 Euro Z 800 V instrument is connected to MI 3155 instrument via Bluetooth communication.
- › Connect current clamp to MI 3144 Euro Z 800 V instrument.
- › Wrap the object under test with the measuring clamp. See **Figure 7.115**. Refer to *MI 3144 Euro Z 800 V Instruction manual* for detailed information.
- › Start the continuous measurement using  or  button.
- › Stop the measurement.
- › Save results (optional).

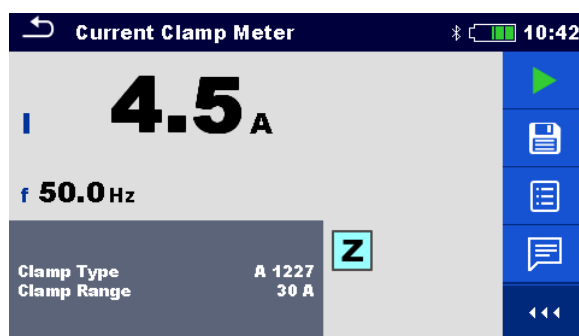

Figure 7.116: Example of Current Clamp Meter measurement result

Measurement results / sub-results

I	Current
f	Frequency

Refer to *MI 3144 Euro Z 800 V Instruction manual* for detailed information

7.33 ISFL – First fault leakage current

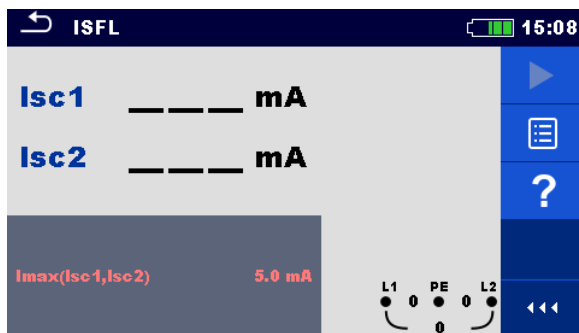

Figure 7.117: ISFL measurement menu

Measurement parameters / limits

Imax(Isc1, Isc2) Maximum first fault leakage current [Off, Custom, 3.0 mA ... 19.5 mA]

Connection diagrams

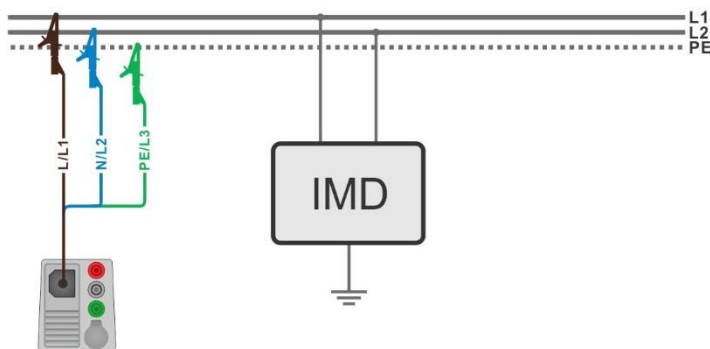

Figure 7.118: Measurement of highest First fault leakage current with 3-wire test lead

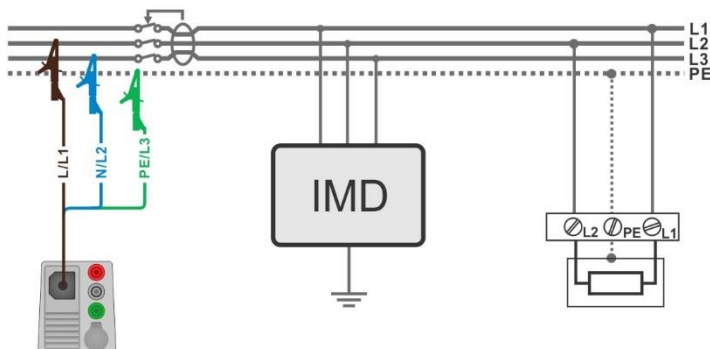

Figure 7.119: Measurement of First fault leakage current for RCD protected circuit with 3-wire test lead

Measurement procedure

- › Enter the **ISFL** function.
- › Set test parameters / limits.
- › Connect test cable to the instrument.

- › Connect 3-wire test lead to the object under test, see **Figure 7.118** and **Figure 7.119**.
- › Start the measurement.
- › Save results (optional).



Figure 7.120: Examples of First fault leakage current measurement result

Measurement results / sub-results

Isc1	First fault leakage current at single fault between L1/PE
Isc2	First fault leakage current at single fault between L2/PE

7.34 IMD – Testing of insulation monitoring devices

This function checks the alarm threshold of insulation monitor devices (IMD) by applying a changeable resistance between L1/PE and L2/PE terminals.

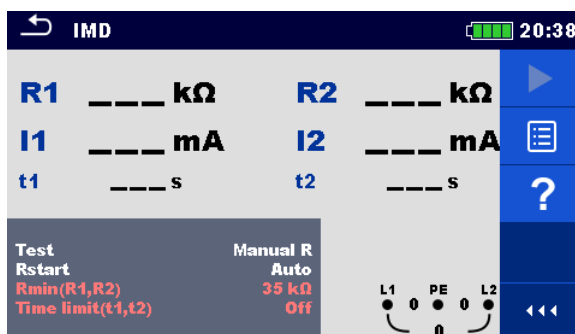

Figure 7.121: IMD test menu

Test parameters / limits

Test	Test mode [MANUAL R, MANUAL I, AUTO R, AUTO I]
Rstart	Starting insulation resistance [Auto, 5 k Ω ... 640 k Ω]
Istart	Starting fault current [Auto, 0.1 mA ... 19.9 mA]
t step	Timer (AUTO R and AUTO I test modes) [1 s ... 99 s]
Rmin(R1,R2)	Min. insulation resistance (R_{LIMIT}) [Off, 5 k Ω ... 640 k Ω]
I _{max} (I1,I2)	Max. fault current (I_{LIMIT}) [Off, 0.1 mA ... 19.9 mA]
Time limit (t1, t2)	Max. activation / disconnection time limit [Off, 1 s]

Connection diagram

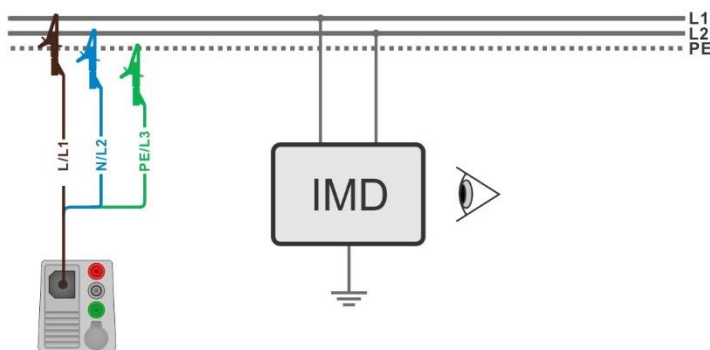











Figure 7.122: Connection with 3-wire test lead



Test procedure (MANUAL R, MANUAL I)

- › Enter the **IMD** function.
- › Set test parameter to MANUAL R or MANUAL I.
Set other test parameters / limits.
- › Connect test cable to the instrument.
- › Connect 3-wire test lead to the object under test, see **Figure 7.122**.
- › Start the measurement.

-
- Use the   or   keys to change insulation resistance¹⁾ until IMD alarms an insulation failure for L1.
-

- Press  or the  key to change line terminal selection to L2.
(If IMD switches off voltage supply, instrument automatically changes line terminal selection to L2 and proceeds with the test when supply voltage is detected.)
-

- Use the   or   keys to change insulation resistance¹⁾ until IMD alarms an insulation failure for L2.
-





- Press the  or the  key.
(If IMD switches off voltage supply, instrument automatically proceeds to the PASS / FAIL / NO STATUS indication.)
-



- Use  to select PASS / FAIL / NO STATUS indication.
-

- Press  or the  key to confirm selection and complete the measurement.
 - Save results (optional).
-





Test procedure (AUTO R, AUTO I)

-
- Enter the **IMD** function.
 - Set test parameter to AUTO R or AUTO I.
 - Set other test parameters / limits.
 - Connect test cable to the instrument.
 - Connect 3-wire test lead to the object under test, see **Figure 7.122**.
 - Start the measurement.
Insulation resistance between L1-PE is decreased automatically according to limit value¹⁾ every time interval selected with timer. To speed up the test press the
-

  or   keys until IMD alarms an insulation failure for L1.

- Press  or the  key to change line terminal selection to L2.
(If IMD switches off voltage supply, instrument automatically changes line terminal selection to L2 and proceeds with the test when supply voltage is detected.)
 - Insulation resistance between L2-PE is decreased automatically according to limit value¹⁾ every time interval selected with timer. To speed up the test press the
-

 or  keys until IMD alarms an insulation failure for L2.

- ▶ Press the  or the  key.
If IMD switches off voltage supply, instrument automatically proceeds to the PASS / FAIL / NO STATUS indication.
- ▶ Use  to select PASS / FAIL / NO STATUS indication.
- ▶ Press  or the  key to confirm selection and complete the measurement.
- ▶ Save results (optional).

*) Starting and ending insulation resistances are determined by selection of IMD test sub-function and test parameters. See tables below:

Sub-function	Rstart parameter	Starting insulation resistance value	Ending insulation resistance value
MANUAL R	Auto	$R_{START} \cong 1.5 \times R_{LIMIT}$	-
	[5 kΩ ... 640 kΩ]	$R_{START} = R_{start}$	-
AUTO R	Auto	$R_{START} \cong 1.5 \times R_{LIMIT}$	$R_{END} \cong 0.5 \times R_{LIMIT}$
	[5 kΩ ... 640 kΩ]	$R_{START} = R_{start}$	$R_{END} \cong 0.5 \times R_{START}$

Table 7.11: Starting / ending insulation resistance values for MANUAL R and AUTO R sub-functions

Sub-function	Istart parameter	Starting insulation resistance value	Ending insulation resistance value
MANUAL I	Auto	$R_{START} \cong 1.5 \times \frac{U_{L1-L2}}{I_{LIMIT}}$	-
	[0.1 mA ... 19.9 mA]	$R_{START} \cong \frac{U_{L1-L2}}{I_{start}}$	-
AUTO I	Auto	$R_{START} \cong 1.5 \times \frac{U_{L1-L2}}{I_{LIMIT}}$	$R_{END} \cong 0.5 \times \frac{U_{L1-L2}}{I_{LIMIT}}$
	[0.1 mA ... 19.9 mA]	$R_{START} \cong \frac{U_{L1-L2}}{I_{start}}$	$R_{END} \cong 0.5 \times \frac{U_{L1-L2}}{I_{start}}$

Table 7.12: Starting / ending insulation resistance values for MANUAL I and AUTO I sub-functions

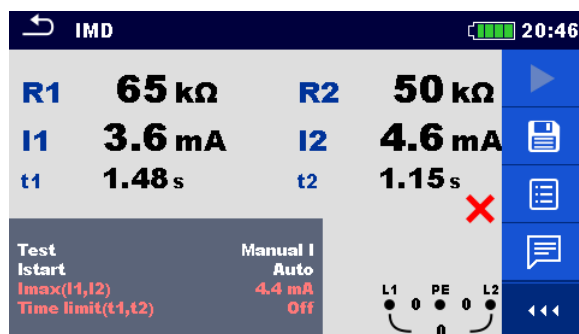
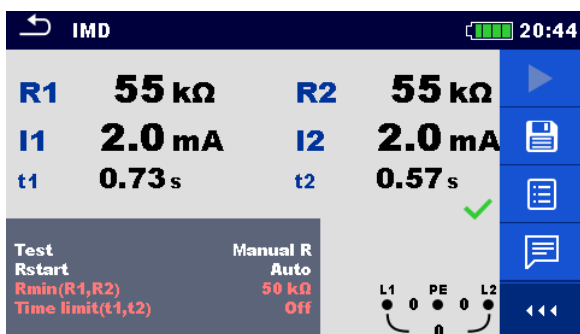

Figure 7.123: Examples of IMD test result

Test results / sub-results

R1	Threshold insulation resistance between L1-PE
I1	Calculated first fault leakage current for R1
t1	Activation / disconnection time of IMD for R1
R2	Threshold insulation resistance between L2-PE
I2	Calculated first fault leakage current for R2
t2	Activation / disconnection time of IMD for R2

Calculated first fault leakage current at threshold insulation resistance is given as $I_{1(2)} = \frac{U_{L1-L2}}{R_{1(2)}}$, where U_{L1-L2} is line-line voltage. The calculated first fault current is the maximum current that would flow when insulation resistance decreases to the same value as the applied test resistance, and a first fault is assumed between opposite line and PE.

If any of the activation / disconnection time result (t1, t2) is out of set limit, overall status of the test is “failed” and cannot be modified manually. Otherwise overall status can be user defined. If activation of IMD device is visual indication and/or audio alert, without voltage disconnection, Time limit (t1,t2) parameter should be set to “Off” to disable timing limitation.

7.35 Rpe – PE conductor resistance



Figure 7.124: PE conductor resistance measurement menu

Measurement parameters / limits

RCD	[Yes, No]
Limit(Rpe)	Max. resistance [Off, Custom, 0.1 Ω ... 20.0 Ω]

Connection diagram

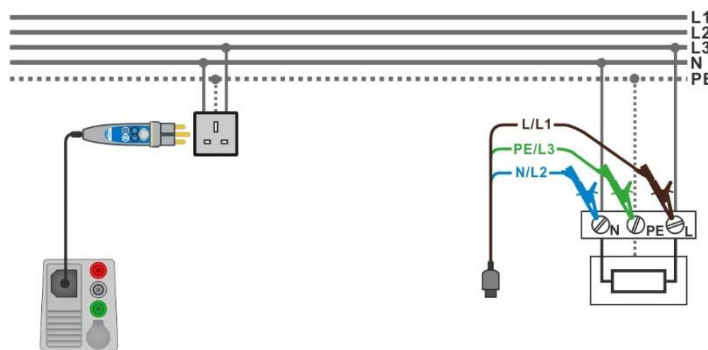

Figure 7.125: Connection of Plug commander and 3-wire test lead

Measurement procedure

- › Enter the **Rpe** function.
- › Set test parameters / limits.
- › Connect test cable to the instrument.
- › Connect 3-wire test lead or Plug commander to the object under test, see **Figure 7.125**.
- › Start the measurement.
- › Save results (optional).

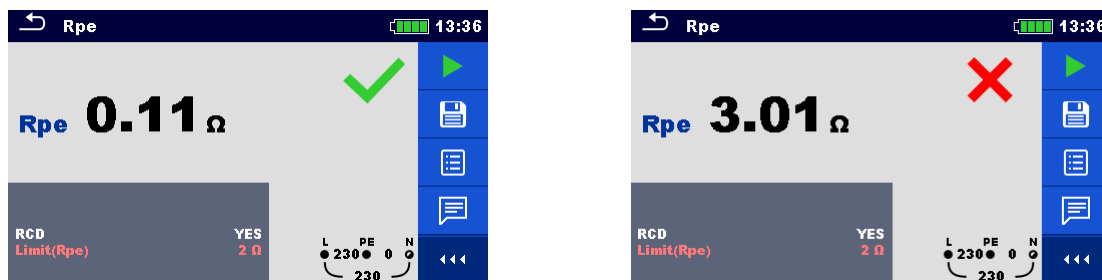

Figure 7.126: Examples of PE conductor resistance measurement result

Measurement results / sub-results

Rpe	PE conductor resistance
-----	-------------------------

7.36 Illumination

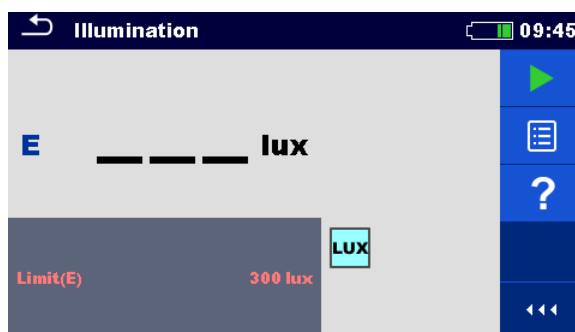

Figure 7.127: Illumination measurement menu

Measurement parameters / limits

Limit(E)	Minimum illumination [Off, Custom, 0.1 lux ... 20 klux]
----------	---

Probe positioning

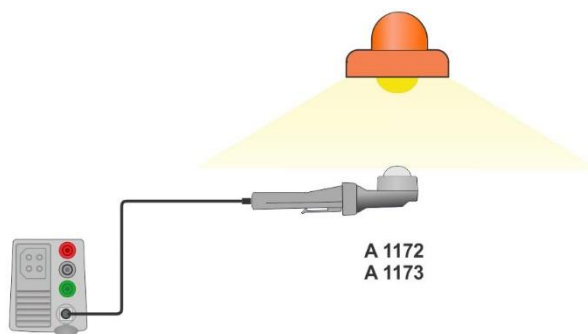

Figure 7.128: LUXmeter probe positioning

Measurement procedure

- › Enter the **Illumination** function.
- › Set test parameters / limits.
- › Connect illumination sensor A 1172 or A 1173 to the instrument.
- › Take the position of LUXmeter probe, see **Figure 7.128**.
Make sure that LUXmeter probe is turned on.
- › Start the continuous measurement.
- › Stop the measurement.
- › Save results (optional).

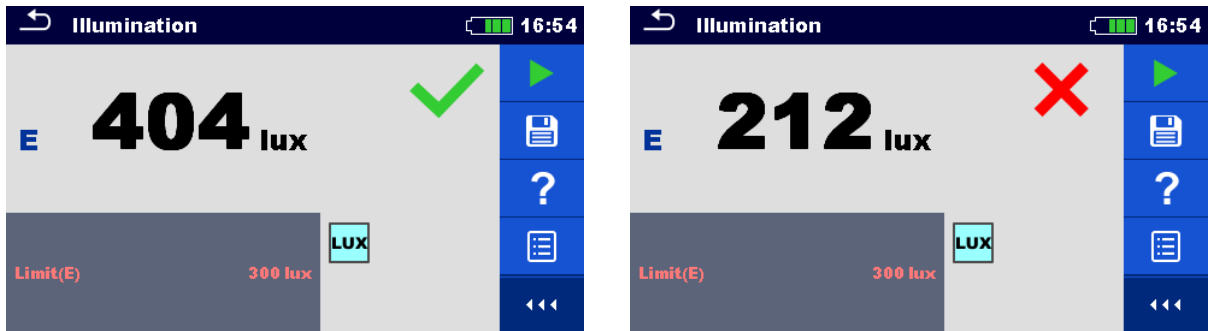

Figure 7.129: Examples of Illumination measurement result

Measurement results / sub-results

E Illumination

7.37 Discharging time

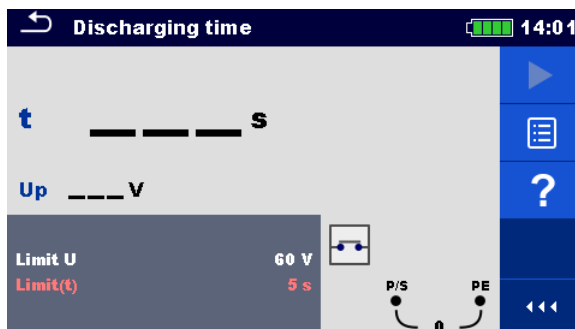

Figure 7.130: Discharging time measurement menu

Measurement parameters / limits

Limit U	Voltage limit [34 V, 60 V, 120 V]
Limit (t)	Time limit [1 s, 5 s]

Measuring principle

The measuring principle of the discharging time function is as following:

- Step 1:** The DUT is connected to supply voltage via an external socket. The instrument monitors the voltage (on supply or internal connections) and internally stores the peak voltage value.
- Step 2:** The DUT is disconnected from the supply and the voltage at the test terminals starts to fall. Once the rms voltage falls for 10 V the instrument starts to measure time.
- Step 3:** After the voltage drops below an internally calculated voltage value the timer is stopped. The instrument re-calculates the measured time to a value as it would be if the disconnection occurred at the maximum voltage value.

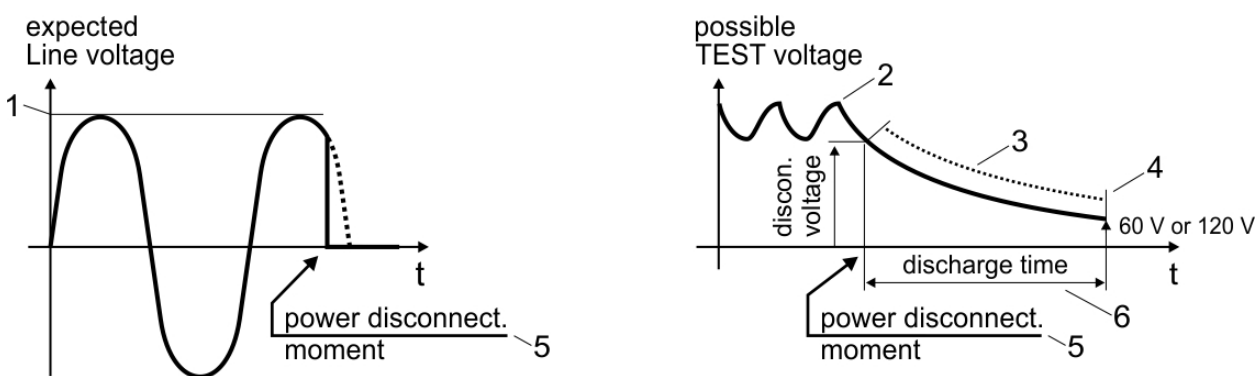

- (1) peak voltage
- (2) voltage at disconnection time
- (3) calculated voltage value
- (4) Ulim
- (5) moment of disconnection
- (6) discharging time

Figure 7.131: Discharging time measuring principle

Connection diagram

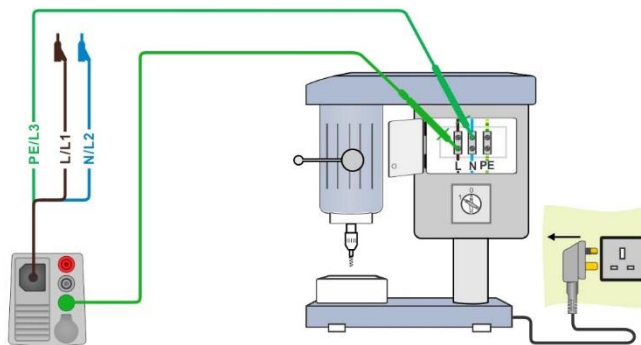

Figure 7.132: Discharging time measurement

Measurement procedure

- ▶ Enter the **Discharging time** function.
- ▶ Set test parameters / limits.
- ▶ Connect 3-wire test lead to the instrument and on the DUT, see **Figure 7.132**.
- ▶ Connect DUT to the mains supply and Switch it ON, see **Figure 7.132**.
- ▶ Start the measurement.
- ▶ Measurement will stop automatically when disconnecting DUT from mains supply.
- ▶ Save results (optional).



Figure 7.133: Discharging time results

Measurement results / sub-results

t	Discharging time
Up	Peak value of voltage at disconnection time

7.38 AUTO TT – Auto test sequence for TT earthing system

Tests / measurements implemented in AUTO TT sequence

- Voltage
- Z line
- Voltage Drop
- Zs rcd
- RCD Uc

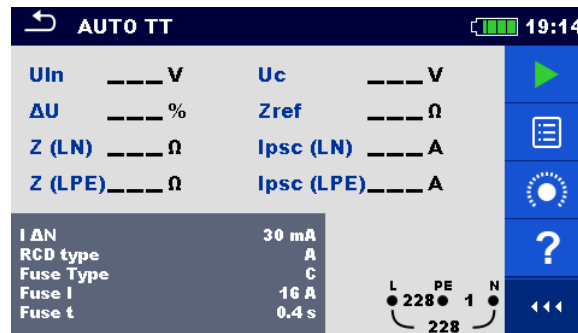

Figure 7.134: AUTO TT menu

Measurement parameters / limits

I ΔN	Rated RCD residual current sensitivity [10 mA, 15 mA, 30 mA, 100 mA, 300 mA, 500 mA, 1000 mA]
RCD type	RCD type [AC, A, F, B, B+]
Selectivity	Characteristic [G, S]
Fuse type	Selection of fuse type [Off, Custom, BS 88-2, BS 88-3, BS 3036, BS 1362, B, C, D]
Fuse I	Rated current of selected fuse
Fuse t	Maximum breaking time of selected fuse
I (ΔU)¹⁾	Rated current for ΔU measurement (custom value)
Z_factor	Z factor [Custom, 0.8, 1]
I test	Test current [Standard, Low]
Limit(ΔU)	Maximum voltage drop [Off, Custom, 3.0 % ... 9.0 %]
Limit Uc	Conventional touch voltage limit [Custom, 12 V, 25 V, 50 V]
Zlim(Z (LN))	Maximum Line impedance for selected fuse or custom value

¹⁾ Applicable if Fuse type is set to Off or Custom.

Refer to **Fuse tables guide** for detailed information on fuse data.

Connection diagram

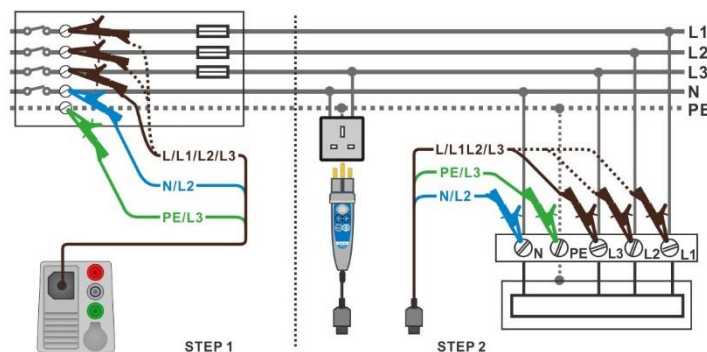

Figure 7.135: AUTO TT measurement

Measurement procedure

- › Enter the **AUTO TT** function.
- › Set test parameters / limits.
- › Measure the impedance Z_{ref} at origin (optional), see chapter **7.19 Voltage Drop**.

- › Connect test cable to the instrument.
- › Connect 3-wire test lead or Plug commander to the object under test, see **Figure 7.135**.
- › Start the Auto test.
- › Save results (optional).

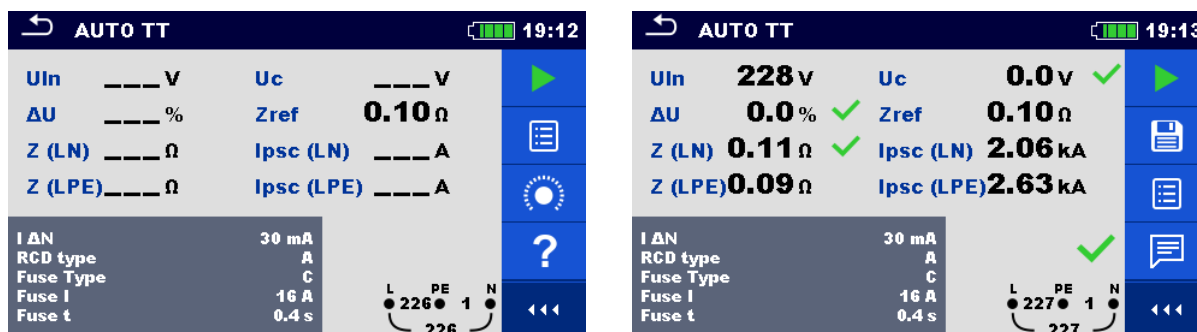

Figure 7.136: Examples of AUTO TT measurement results

Measurement results / sub-results

U_{ln}	Voltage between phase and neutral conductors
ΔU	Voltage drop
Z (LN)	Line impedance
Z (LPE)	Loop impedance
U_c	Contact voltage
Z_{ref}	Reference line impedance
I_psc (LN)	Prospective short-circuit current
I_psc (LPE)	Prospective fault current

7.39 AUTO TN (RCD) – Auto test sequence for TN earthing system with RCD

Tests / measurements implemented in AUTO TN (RCD) sequence

- ____ Voltage
- ____ Z line
- ____ Voltage Drop
- ____ Zs rcd
- ____ Rpe rcd

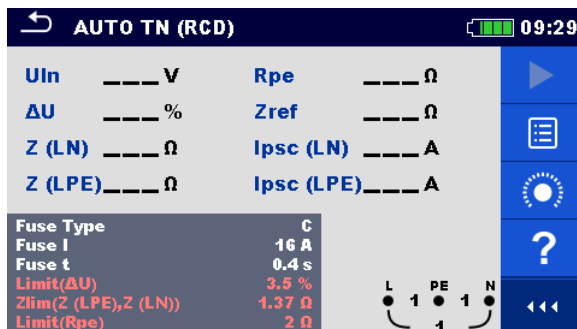

Figure 7.137: AUTO TN (RCD) menu

Measurement parameters / limits

Fuse type	Selection of fuse type [Off, Custom, BS 88-2, BS 88-3, BS 3036, BS 1362, B, C, D]
Fuse I	Rated current of selected fuse
Fuse t	Maximum breaking time of selected fuse
I (ΔU)¹⁾	Rated current for ΔU measurement (custom value)
Z_factor	Z factor [Custom, 0.8, 1]
I test	Test current [Standard, Low]
Limit(ΔU)	Maximum voltage drop [Off, Custom, 3.0 % ... 9.0 %]
Zlim(Z (LPE), Z (LN))	Maximum Line / Loop impedance for selected fuse or custom value
Limit (Rpe)	Max. resistance [Off, Custom, 0.1 Ω ... 20.0 Ω]

¹⁾ Applicable if Fuse type is set to Off or Custom.

Refer to **Fuse tables guide** for detailed information on fuse data.

Connection diagram

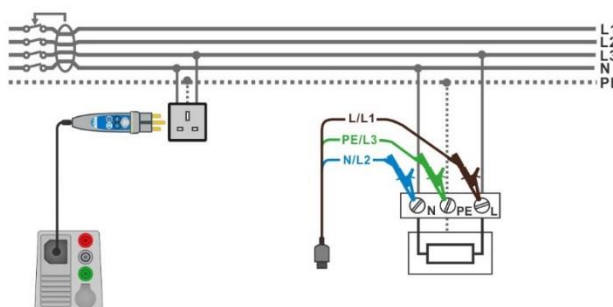

Figure 7.138: AUTO TN (RCD) measurement

Measurement procedure

- › Enter the **AUTO TN (RCD)** function.
- › Set test parameters / limits.
- › Measure the impedance Z_{ref} at origin (optional), see chapter **7.19 Voltage Drop**.
- › Connect test cable to the instrument.
- › Connect 3-wire test lead or Plug commander to the object under test, see **Figure 7.138**.
- › Start the Auto test.
- › Save results (optional).



Figure 7.139: Examples of AUTO TN (RCD) measurement results

Measurement results / sub-results

U_{In}	Voltage between phase and neutral conductors
ΔU	Voltage drop
$Z (LN)$	Line impedance
$Z (LPE)$	Loop impedance
R_{pe}	PE conductor resistance
Z_{ref}	Reference Line impedance
$I_{psc} (LN)$	Prospective short-circuit current
$I_{psc} (LPE)$	Prospective fault current

7.40 AUTO TN – Auto test sequence for TN earthing system without RCD

Tests / measurements implemented in AUTO TN sequence

- Voltage
- Z line
- Voltage Drop
- Z loop
- Rpe

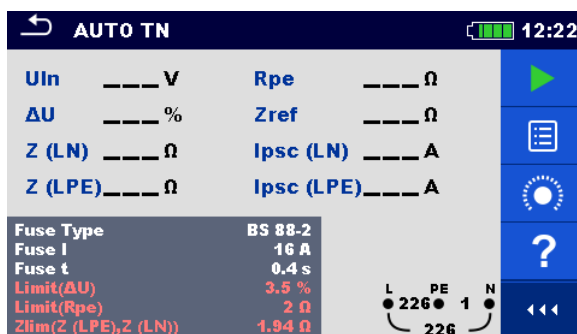

Figure 7.140: AUTO TN menu

Measurement parameters / limits

Fuse type	Selection of fuse [Off, Custom, BS 88-2, BS 88-3, BS 3036, BS 1362, B, C, D]
Fuse I	Rated current of selected fuse
Fuse t	Maximum breaking time of selected fuse
I (ΔU)¹⁾	Rated current for ΔU measurement (custom value)
Z_factor	Z factor [Custom, 0.8, 1]
Limit(ΔU)	Maximum voltage drop [Off, Custom, 3.0 % ... 9.0 %]
Limit(Rpe)	Max. resistance [Off, Custom, 0.1 Ω ... 20.0 Ω]
Zlim(Z (LPE), Z (LN))	Maximum Line / Loop impedance for selected fuse or custom value

¹⁾ Applicable if Fuse type is set to Off or Custom.

Refer to **Fuse tables guide** for detailed information on fuse data.

Connection diagram

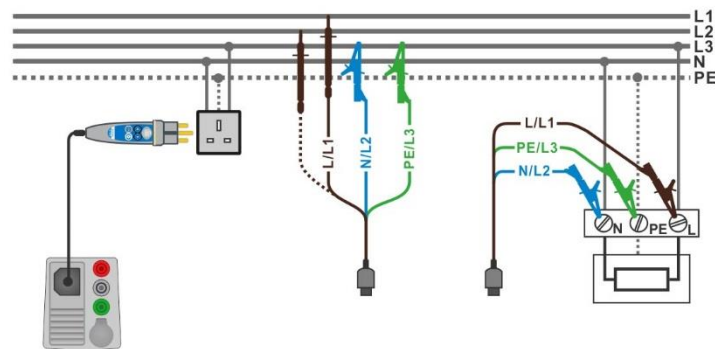

Figure 7.141: AUTO TN measurement

Measurement procedure

- › Enter the **AUTO TN** function.
- › Set test parameters / limits.
- › Measure the impedance Z_{ref} at origin (optional), see chapter **7.19 Voltage Drop**.
- › Connect test cable to the instrument.
- › Connect 3-wire test lead or Plug commander to the object under test, see **Figure 7.141**.
- › Start the Auto test.
- › Save results (optional).



Figure 7.142: Examples of AUTO TN measurement results

Measurement results / sub-results

UIn	Voltage between phase and neutral conductors
ΔU	Voltage drop
Z (LN)	Line impedance
Z (LPE)	Loop impedance
Rpe	PE conductor resistance
Zref	Reference Line impedance
IpSC (LN)	Prospective short-circuit current
IpSC (LPE)	Prospective fault current

7.41 AUTO IT – Auto test sequence for IT earthing system

Tests / measurements implemented in AUTO IT sequence

- ____ Voltage
- ____ Z line
- ____ Voltage Drop
- ____ ISFL
- ____ IMD

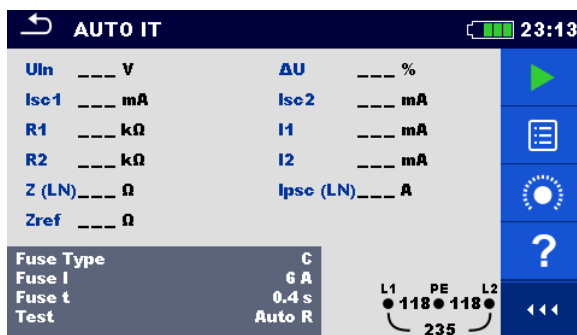

Figure 7.143: AUTO IT menu

Measurement parameters / limits

Fuse type	Selection of fuse type [Off, Custom, BS 88-2, BS 88-3, BS 3036, BS 1362, B, C, D]
Fuse I	Rated current of selected fuse
Fuse t	Maximum breaking time of selected fuse
I (ΔU)¹⁾	Rated current for ΔU measurement (custom value)
Test	Test mode [MANUAL R, MANUAL I, AUTO R, AUTO I]
t step	Timer (AUTO R and AUTO I test modes) [1 s ... 99 s]
Z_factor	Z factor [Custom, 0.8, 1]
Limit(ΔU)	Maximum voltage drop [Off, Custom, 3.0 % ... 9.0 %]
Rmin(R1,R2)	Min. insulation resistance [Off, 5 kΩ ... 640 kΩ],
I_{max}(I1,I2)	Max. fault current [Off, 0.1 mA ... 19.9 mA]
I_{max}(Isc1,Isc2)	Maximum first fault leakage current [Off, Custom, 3.0 mA ... 19.5 mA]
Zlim(Z (LN))	Maximum Line impedance for selected fuse or custom value

¹⁾ Applicable if Fuse type is set to Off or Custom.

Refer to **Fuse tables guide** for detailed information on fuse data.

Connection diagram

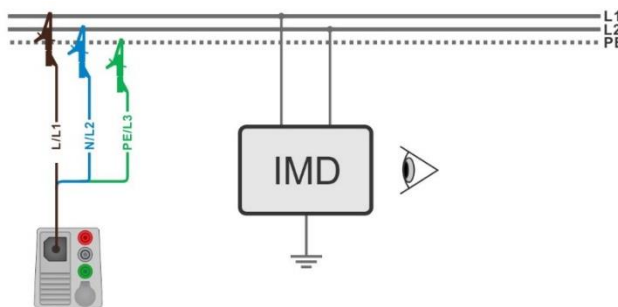

Figure 7.144: AUTO IT measurement

Measurement procedure

- › Enter the **AUTO IT** function.
- › Set test parameters / limits.
- › Measure the impedance Z_{ref} at origin (optional), see chapter **7.19 Voltage Drop**.
- › Connect test cable to the instrument.
- › Connect 3-wire test lead to the object under test, see **Figure 7.144**.
- › Start the Auto test.
- › Save results (optional).

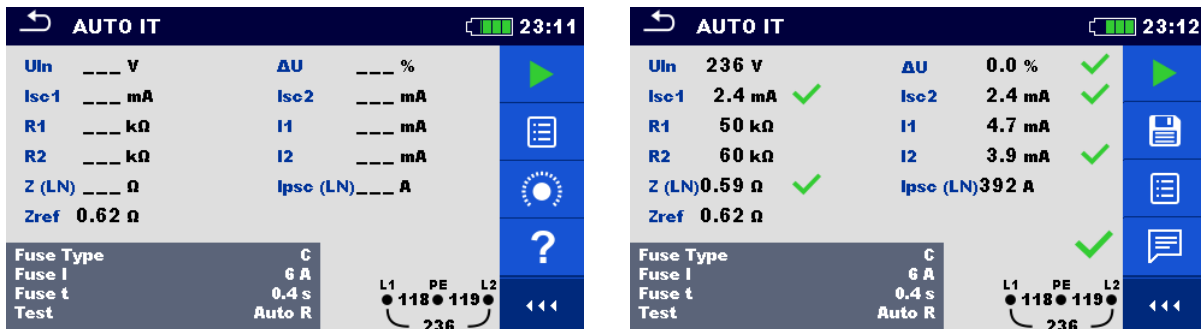

Figure 7.145: Examples of AUTO IT measurement results

Measurement results / sub-results

Uln	Voltage between phases L1 and L2
ΔU	Voltage drop
Isc1	First fault leakage current at single fault between L1/PE
Isc2	First fault leakage current at single fault between L2/PE
R1	Threshold insulation resistance between L1-PE
R2	Threshold insulation resistance between L2-PE
I1	Calculated first fault leakage current for R1
I2	Calculated first fault leakage current for R2
Z (LN)	Line impedance
Zref	Reference Line impedance
Ipsc (LN)	Prospective short-circuit current

7.42 Locator

This function is intended for tracing mains installation, like:

- › Tracing lines,
- › Finding shorts, breaks in lines,
- › Detecting fuses.

The instrument generates test signals that can be traced with the handheld tracer receiver R10K. See **Appendix B – Locator receiver R10K** for additional information.

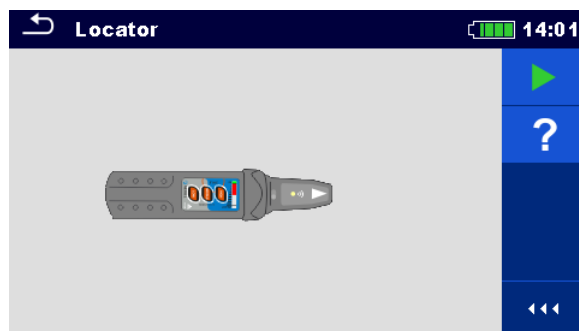

Figure 7.146: Locator main screen

Typical applications for tracing electrical installation

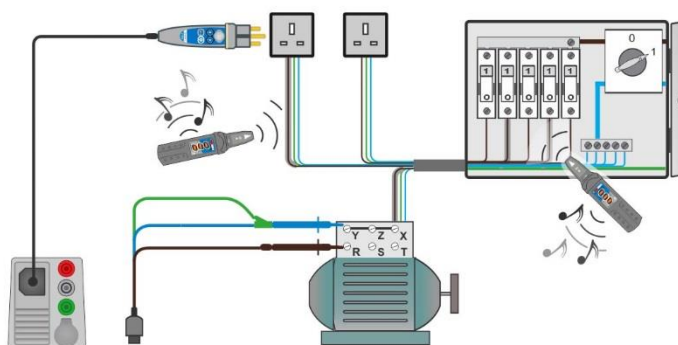

Figure 7.147: Tracing wires under walls and in cabinets

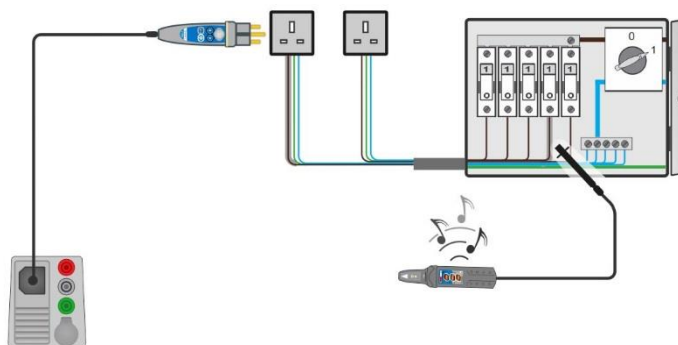



Figure 7.148: Locating individual fuses

Line tracing procedure

- › Select **Locator** function in **Other** menu.
- › Connect test cable to the instrument.
- › Connect 3-wire test lead or Plug commander to the tested object (see **Figure 7.147** and **Figure 7.148**).
- › Press the  key.
- › Trace lines with receiver (in IND mode) or receiver plus its optional accessory.
- › To stop tracing press the  key again.

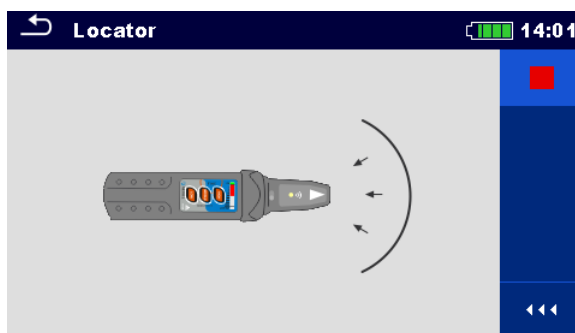

Figure 7.149: Locator active

7.43 Visual and Functional inspections

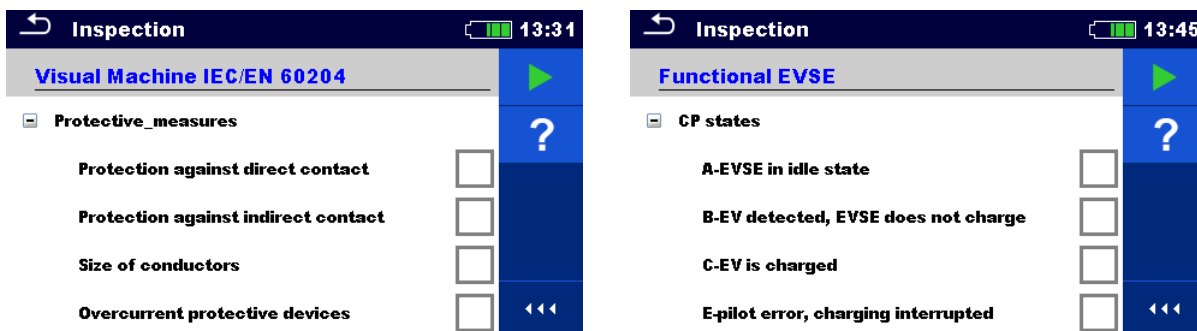

Figure 7.150: Examples of Visual / Functional inspection menu

Inspection

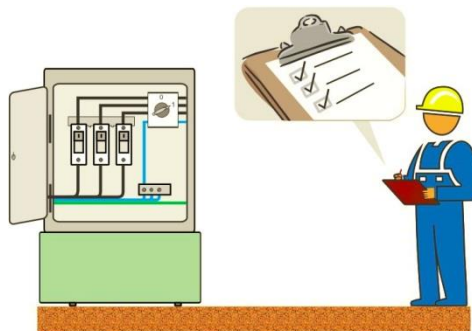

Figure 7.151: Visual / Functional inspection test circuit

Visual / Functional inspection procedure

- › Select the appropriate inspection test from *Visual* or *Function* menu.
- › Start the inspection.
- › Perform the inspection of the item under test.
- › Apply appropriate ticker(s) to items of inspection.
- › End inspection.
- › Save results (optional).

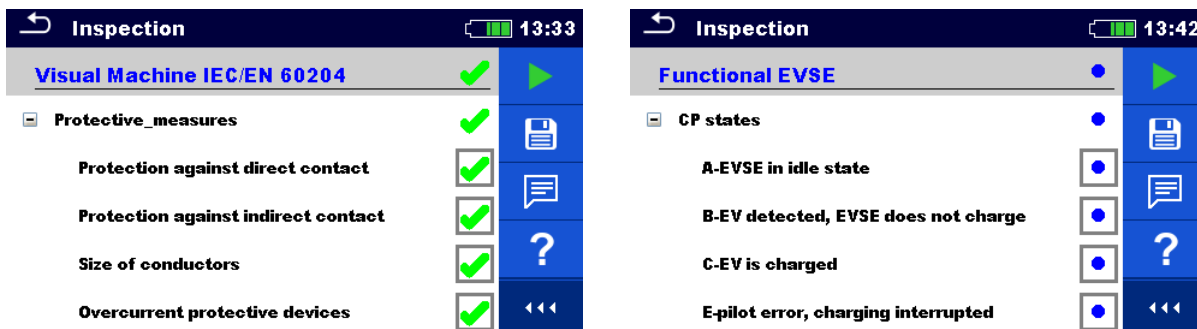

Figure 7.152: Examples of Visual / Functional inspection results

7.44 Measurements using adapter MD 9273

Clamp MD 9273 can be used as an adapter connected via Bluetooth® communication with EurotestXD in manner to expand it Power quality Test range. Supported test measurements and signal recordings are:

- P – Power CLAMP
- U – Voltage CLAMP
- I – Current CLAMP
- I_{max} – Inrush CLAMP
- h_n – Harmonics U CLAMP
- h_n – Harmonics I – CLAMP

Required test is selected from the CLAMP section of the Single Tests menu, see **Figure 7.160** below. Menu is available only when Adapter MD 9273 is set, see chapters **4.6.8 Settings** and **9.3 Communication with adapters** for details.

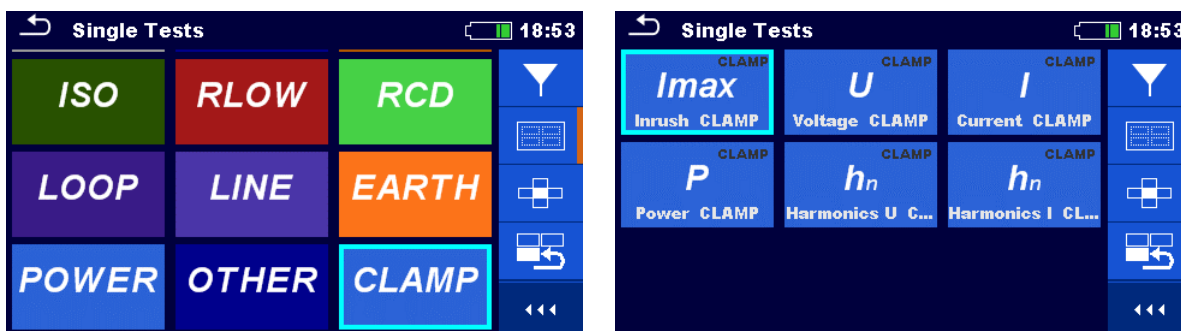

Figure 7.153: CLAMP single test selection menu

Selected test is configured from EurotestXD. Adapter MD 9273 acquires test signals, process measurements and send results to the EurotestXD. Results are presented on the instrument screen and can be saved to the Workspace memory for later use.

7.44.1 Power CLAMP

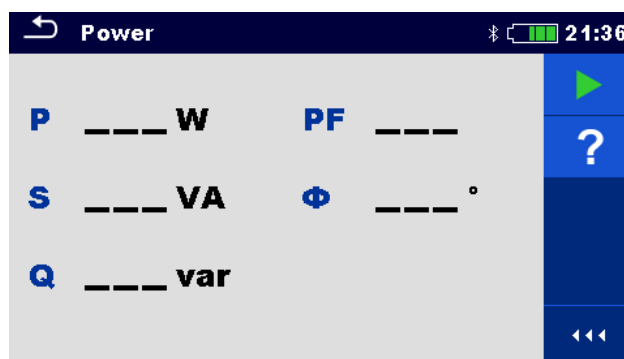

Figure 7.154: Power CLAMP menu

Measurement parameters

There are no parameters to be set.

Connection diagram

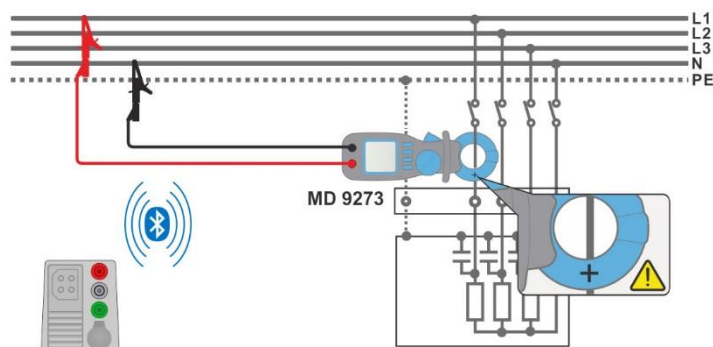

Figure 7.155: Power CLAMP connection

Measurement procedure

- › Connect MD 9273 to the item to be tested and set Bluetooth® mode.
- › Enter the **Power CLAMP** function and wait for active Bluetooth® communication sign.
- › Start the continuous measurement.
- › Stop the measurement.
- › Save results (optional).



Figure 7.156: Power CLAMP results

Measurement results / sub-results

P	Active power
S	Apparent power
Q	Reactive power (capacitive or inductive)
PF	Power factor (capacitive or inductive)
Φ	Phase displacement between voltage and current in degrees

Note:

Voltage test terminals connection and current flow toward load should be taken into account; the red voltage terminal should be connected to the Line terminal and the jaw should be correctly oriented, to obtain positive sign of Power test result. If Power test result has negative sign, connection of voltage terminal or jaw orientation are opposite and the result of phase displacement angle has opposite sign too. Consequently, load character determination (capacitive or inductive) is mismatched.

7.44.2 Voltage CLAMP

Figure 7.157: Voltage CLAMP menu

Measurement parameters

h	Harmonic setup [1 to 19, 1 st is fundamental frequency]
----------	--

Connection diagram

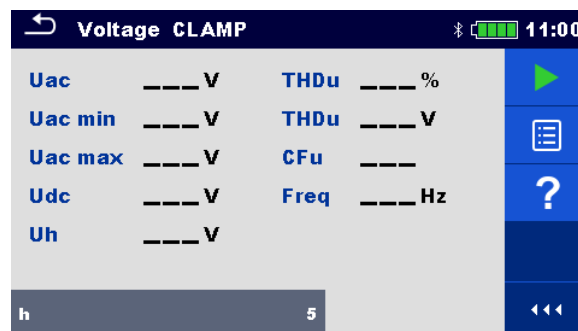
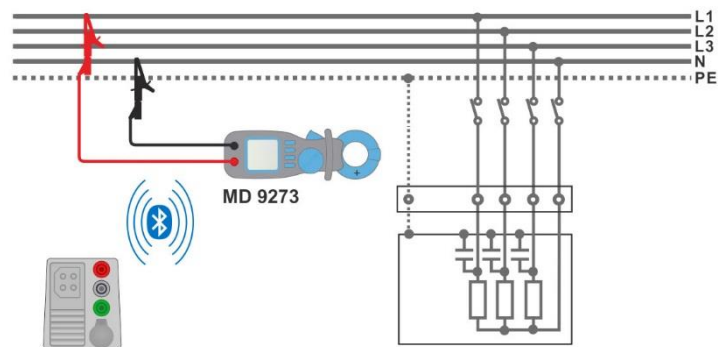

Figure 7.158: Voltage CLAMP connection

Measurement procedure

- › Connect MD 9273 to the item to be tested and set Bluetooth® mode.
- › Enter the **Voltage CLAMP** function and wait for active Bluetooth® communication sign.
- › Set test parameter.
- › Start the continuous measurement.
- › Stop the measurement.
- › Save results (optional).

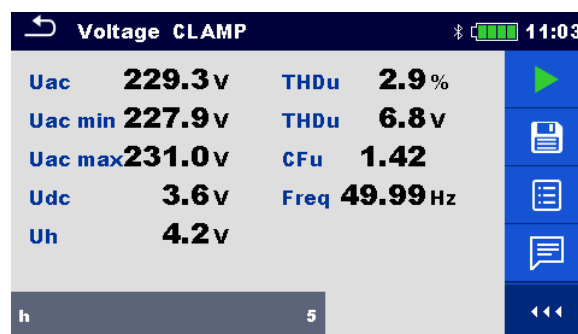

Figure 7.159: Voltage CLAMP results

Measurement results / sub-results

Uac	Effective ac voltage value – last obtained result
Uac min	Minimum effective ac voltage value during measurement time duration
Uac max	Maximum effective ac voltage value during measurement time duration
Udc	DC voltage value
THDu [V]	Effective voltage value of all harmonics (without voltage value at fundamental frequency)
THDu [%]	Total harmonic distortion
Uh	Effective voltage value of set harmonic
CFu	Voltage Crest factor – peak voltage to effective ac voltage ratio
Freq	Fundamental frequency

7.44.3 Current CLAMP

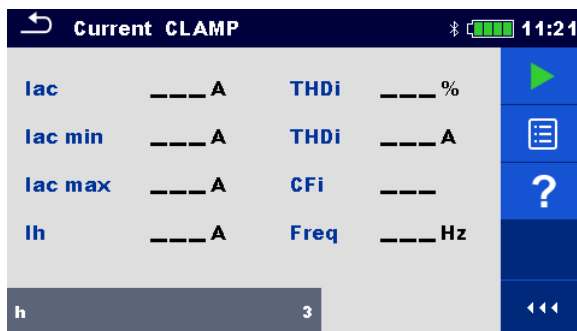

Figure 7.160: Current CLAMP menu

Measurement parameters

h	Harmonic setup [1 to 19, 1 st is fundamental frequency]
---	--

Connection diagram

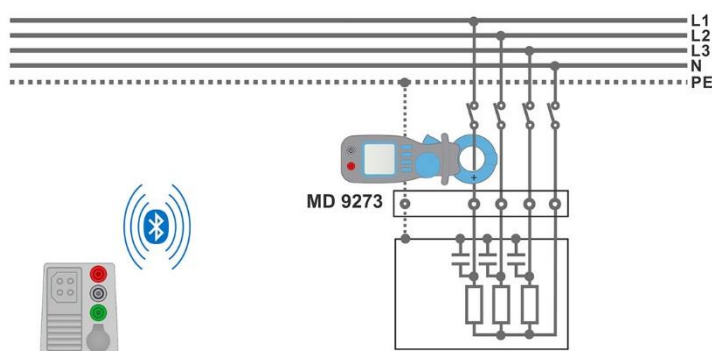

Figure 7.161: Current CLAMP connection

Measurement procedure

- › Connect MD 9273 to the item to be tested and set Bluetooth® mode.
- › Enter the **Current CLAMP** function and wait for active Bluetooth® communication sign.
- › Set test parameter.
- › Start the continuous measurement.
- › Stop the measurement.
- › Save results (optional).

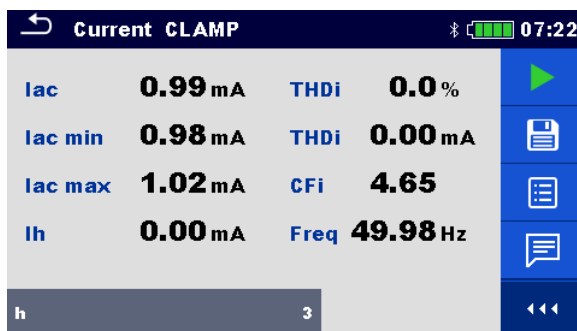

Figure 7.162: Current CLAMP results

Measurement results / sub-results

Iac	Effective ac current value – last obtained result
Iac min	Minimum effective ac current value during measurement time duration
Iac max	Maximum effective ac current value during measurement time duration
THDi [A]	Effective current value of all harmonics (without current value at fundamental frequency)
THDi [%]	Total harmonic distortion
Ih	Effective current value of set harmonic
CFi	Current Crest factor – peak current to effective current ratio
Freq	Fundamental frequency

7.44.4 Inrush CLAMP

Inrush CLAMP function records current and voltage transients that occur when load is turned on. Recorded values are presented on the screen of the instrument in separate charts. Two event triggers can be set, Voltage dip or Inrush current. Only one trigger can be active at the same time; when one is set, the other is switched off automatically. Voltage dip trigger is effective only if MD 9273 Voltage input is connected to supply circuit. Minimum effective circuit voltage is calculated during recorded transient and compared with set voltage threshold. Inrush current trigger is effective only if the wire with flowing current is embraced with MD 9273 jaws. Maximum effective ac circuit current is calculated during recorded transient and compared with set Inrush threshold.

After Inrush Test is started, MD 9273 starts to record signals and waits for trigger event to

occur, which is symbolised with sign  on the bottom right of the screen. Displayed chart is divided in Pre-trigger area, presenting first second of total set chart duration time and transient event area – rest of the chart duration time.

Trigger event occur automatically, when one of the recorder signals achieve set threshold level or can be initiated manually by tapping on the  icon within command menu on the right of the screen, see right screen picture of the figure below.



Figure 7.163: Inrush CLAMP menu – setup on the left, waiting for trigger on the right

Test parameters

Inrush threshold	Inrush current threshold setting [Off, 5 mA ... 90 A]
Voltage threshold	Voltage dip threshold setting [Off, 50 V ... 500 V]
Duration	Recording duration [3 s, 10 s]

Connection diagram

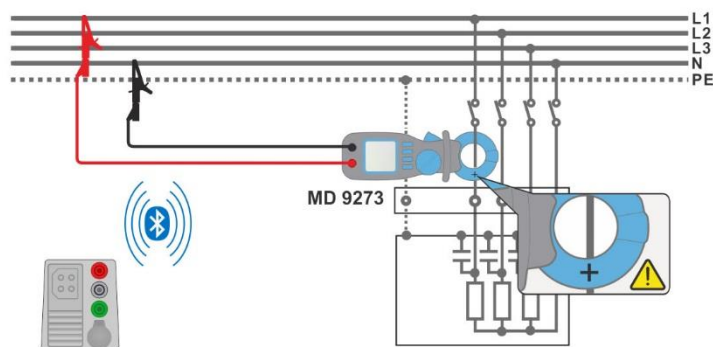

Figure 7.164: Inrush CLAMP connection

Test procedure

- › Connect MD 9273 to the item to be tested and set Bluetooth® mode.
- › Enter the **Inrush CLAMP** function and wait for active Bluetooth® communication sign.
- › Set test parameters.
- › Set charts Y value range¹⁾ within expected values (optional; could be set later, after the test)
- › Start the test.
- › Initiate set threshold event or manually trigger test recording.
- › Save results (optional) after test is finished and results and recorded charts are presented on the screen.

- 1) Chart range selection:
- › Voltage range [100 mV/div ... 100 V/div]
 - › Current range [10 mA/div ... 200 A/div]

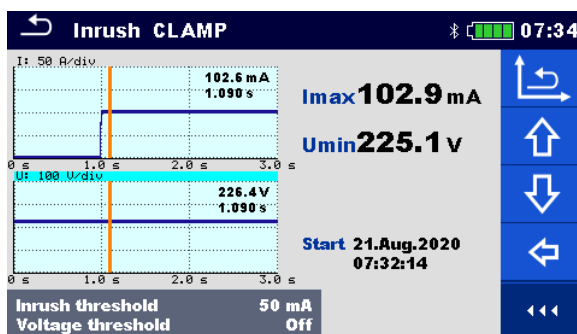

Figure 7.165: Inrush CLAMP results

Test results / sub-results

I:	Inrush current chart ²⁾ range
	Recorded effective ac current value at cursor position
	Relative time of recorded data at cursor position
U:	Circuit voltage chart ²⁾ range
	Recorded effective ac voltage value at cursor position
	Relative time of recorded data at cursor position
I_{max}	Inrush current maximum value of recorded data
U_{min}	Circuit voltage dip minimum value of recorded data

Uac	Effective ac voltage (within the measurement)
Iac	Effective ac current (within the measurement)
Start	Inrush test start recording time (from Master Instrument)

- 2) Tap on chart area or drag graph line cursor to present chart value at chosen time. Use left / right arrow keys for smooth setting.

7.44.5 Harmonics U CLAMP

Harmonics (1 through to 19) are measured and displayed in the chart as an absolute magnitude of the signal or as a percentage of the signal value at the fundamental frequency (the 1st harmonic h1). Absolute magnitude or percent value display is chosen by Type parameter setting.

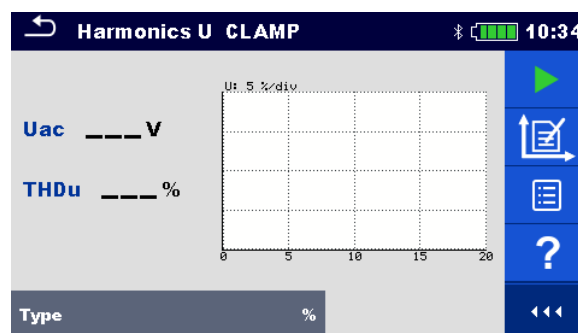

Figure 7.166: Harmonics U CLAMP menu

Measurement parameters

Type	[%, V]
	% – harmonics and distortion are displayed as relative value
	V – harmonics and distortion are displayed as absolute value

Connection diagram

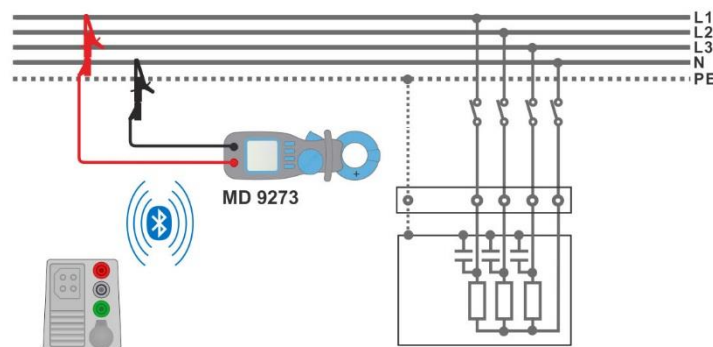

Figure 7.167: Harmonics U CLAMP connection

Measurement procedure

- Connect MD 9273 to the item to be tested and set Bluetooth[®] mode.
- Enter the **Harmonics U CLAMP** function and wait for active Bluetooth[®] communication.
- Set Type parameter.

- › Set charts Y value range³⁾ within expected values (optional; could be set later, after the test).
- › Start the continuous measurement.
- › Stop the measurement.
- › Save results (optional).

³⁾ Chart Voltage range selection: [100 mV/div ... 100 V/div]

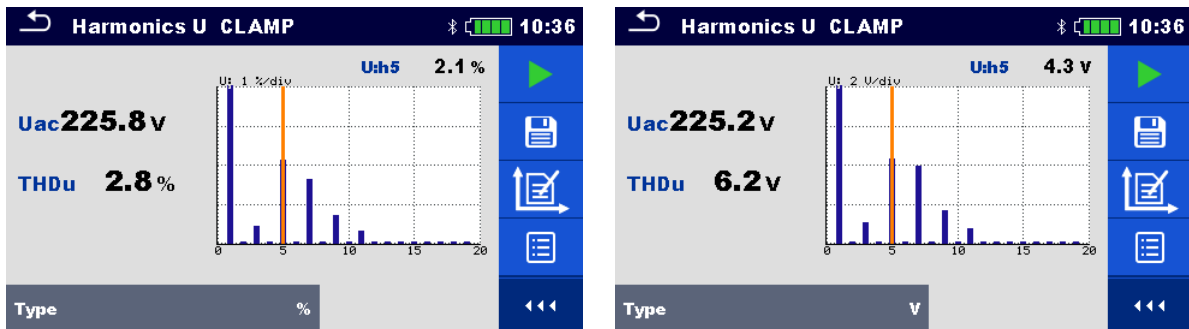

Figure 7.168: Harmonics U CLAMP results

Measurement results / sub-results

U:	Harmonics chart range
Uac	Effective ac voltage value
THDu [%]	Total harmonic distortion
THDu [V]	Effective voltage value of all harmonics (without voltage value at fundamental frequency)
U:h5 [%]	Relative value of 5 th harmonic ⁴⁾
U:h5 [V]	Absolute voltage of 5 th harmonic ⁴⁾

⁴⁾ Tap on chart area at chosen harmonic to present its value.

7.44.6 Harmonics I CLAMP

Harmonics (1 through to 19) are measured and displayed in the chart as an absolute magnitude of the signal or as a percentage of the signal value at the fundamental frequency (the 1st harmonic h1). Absolute magnitude or percent value display is chosen by Type parameter setting.

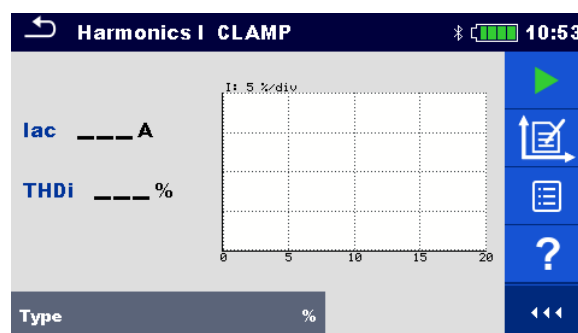

Figure 7.169: Harmonics I CLAMP menu

Measurement parameters

Type	[%, A]
-------------	--------

% – harmonics and distortion are displayed as relative value
 A – harmonics and distortion are displayed as absolute value

Connection diagram

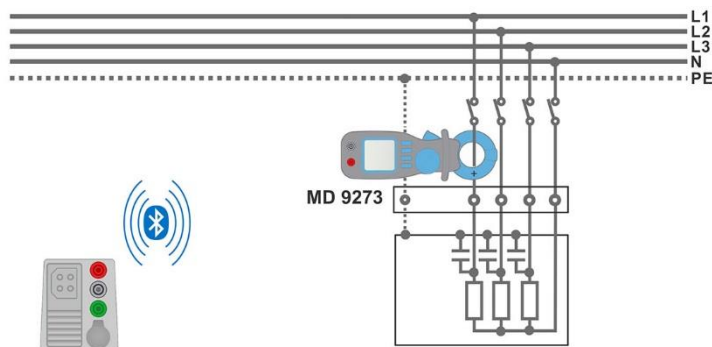

Figure 7.170: Harmonics I CLAMP connection

Measurement procedure

- ▶ Connect MD 9273 to the item to be tested and set Bluetooth® mode.
- ▶ Enter the **Harmonics I CLAMP** function and wait for active Bluetooth® communication.
- ▶ Set Type parameter.
- ▶ Set charts Y value range within expected values (optional; could be set later, after the test).
- ▶ Start the continuous measurement.
- ▶ Stop the measurement.
- ▶ Save results (optional).

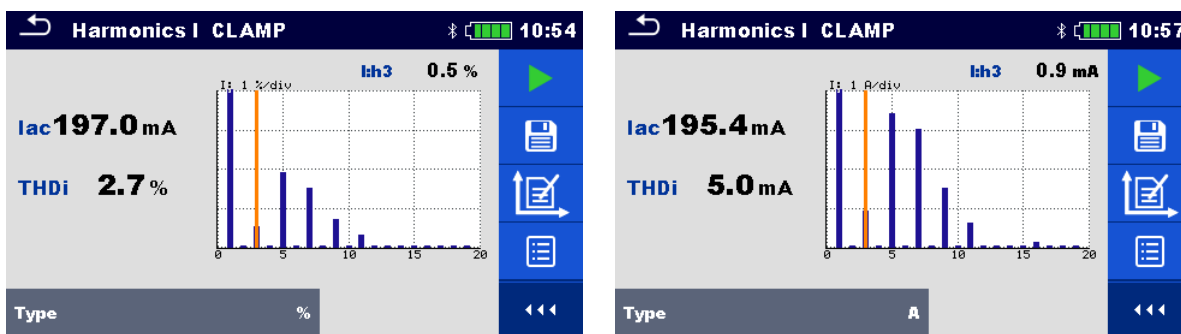

Figure 7.171: Harmonics I CLAMP results

Measurement results / sub-results

I	Harmonics chart
Iac	Effective ac current value
THDi [%]	Total harmonic distortion
THDi [A]	Effective current value of all harmonics (without current value at fundamental frequency)
I:h3 [%]	Relative value of 3 rd harmonic ⁵⁾
I:h3 [A]	Absolute current value of 3 rd harmonic ⁵⁾

⁵⁾ Tap on chart area at chosen harmonic to present its value.

8 Auto Sequences®

Pre-programmed sequences of measurements can be carried out in Auto Sequences® menu. The sequence of measurements, their parameters and flow of the sequence can be programmed. The results of an Auto sequence® can be stored in the memory together with all related information.

Auto Sequences® can be pre-programmed on PC with the Metrel ES Manager software and uploaded to the instrument. Refer to chapter **Appendix E - Programming of Auto Sequences® on Metrel ES Manager** for detailed information on programming Auto Sequences®.

On the instrument, parameters and limits of individual single test in the Auto Sequence® can be changed / set.





8.1 Selection of Auto Sequences®

The Auto Sequence® list from Auto Sequence® groups menu should be selected first. Refer to chapter **4.9 Auto Sequence® groups** for more details.

8.1.1 Selecting an active Auto Sequence® group in Auto Sequences® menu

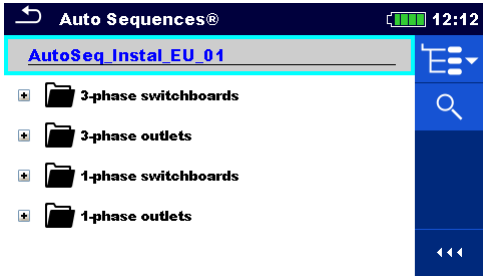
Auto Sequences® and Auto Sequence® group menus are interconnected so an active Auto Sequence® group can be selected also in the Auto Sequences® menu.

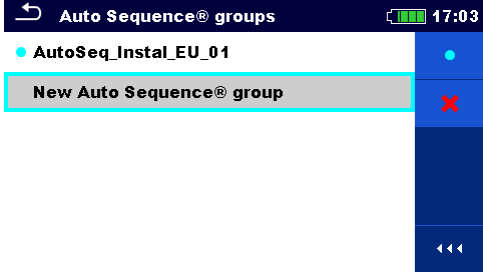
Procedure

- | | | |
|---|---|--|
| ① |  | Tap on the active Auto Sequence® group header in Auto Sequences® Menu. |
| ② |  | Opens a list of Auto Sequence® groups in Control panel. |
| ③ |  | Selects desired Auto Sequence® group from a list of groups. |
| ④ |  | Confirms a new selection. |

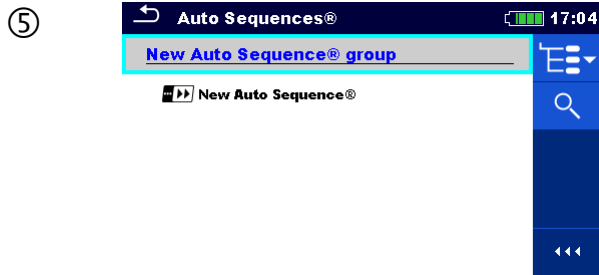

New Auto Sequence® group is selected and all Auto Sequences® within that group are displayed on the screen.

8.1.2 Searching in Auto Sequences® menu

In Auto Sequence® menu it is possible to search for Auto Sequences® on base of their Name or Short code.

Procedure

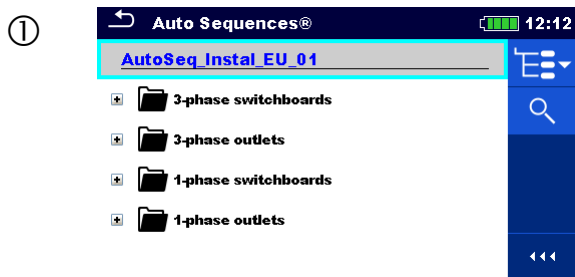

Search function is available from the active Auto Sequence® group header line.



Select Search in control panel to open Search setup menu.

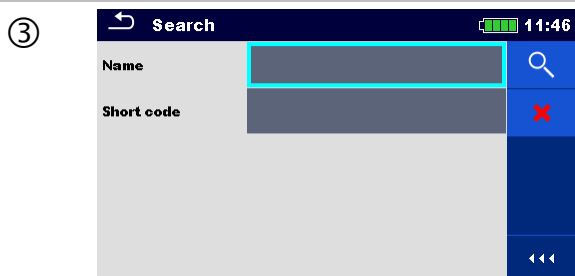

The parameters that can be searched for are displayed in the Search setup menu.



The search can be narrowed by entering a text in the Name and Short code fields.

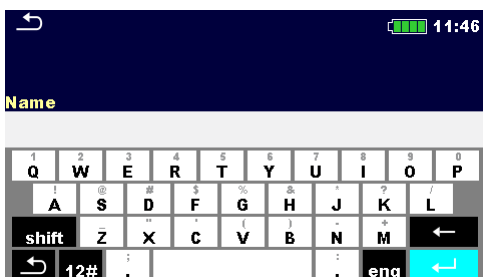

Strings can be entered by using the on-screen keyboard.



Clears all filters. Sets filters to default value.



Searches through the active Auto Sequence® group according to the set filters. The results are shown in the Search results screen presented on **Figure 8.1**.

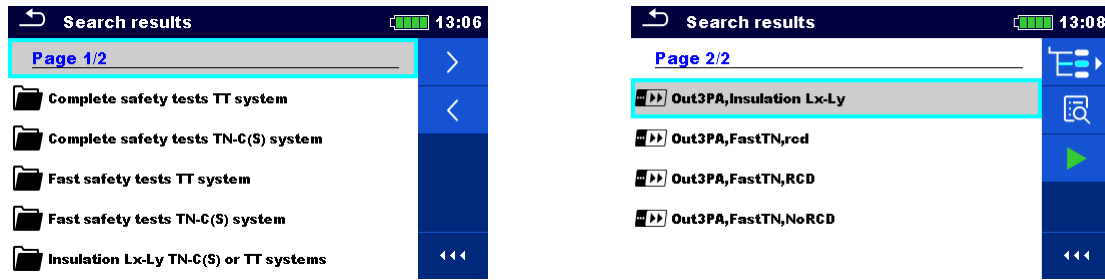







Figure 8.1: Search results screen – Page view (left), Auto Sequence® selected (right)

Options

	Next page.
	Previous page.
	Goes to location in Auto Sequences® menu.
	Goes to Auto Sequence® view menu.
	Starts the selected Auto Sequence®.

Note:

- Search result page consist of up to 50 results.

8.1.3 Organization of Auto Sequences® in Auto Sequences® menu

The Auto Sequences® to be carried out can be selected from the Main Auto Sequences® menu. This menu can be organized in a structural manner with folders, sub-folders and Auto Sequences®. Auto Sequence® in the structure can be the original Auto Sequence® or a shortcut to the original Auto Sequence®.

Auto Sequences® marked as shortcuts and the original auto Sequences® are coupled. Changing of parameters or limits in any of the coupled Auto Sequences® will influence on the original Auto Sequence® and all its shortcuts.

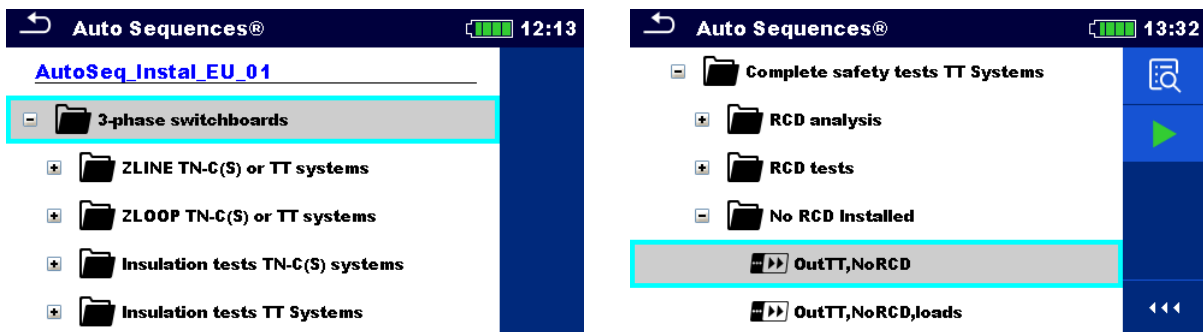



Figure 8.2: Examples of organized Auto Sequences® in main Auto Sequences® menu

Options

	Auto Sequence® The original Auto Sequence®.
	Auto Sequence® A shortcut to the original Auto Sequence®.



Enters menu for more detail view of selected Auto sequence®. This option should also be used if the parameters / limits of the selected Auto Sequence® have to be changed. Refer to chapter **8.2.1 Auto Sequence® view menu** for more information.



Starts the selected Auto Sequence®. The instrument immediately starts the Auto sequence®.



Searches within the Auto Sequences® menu. Refer to chapter **8.1.2 Searching in Auto Sequences® menu** for more information.

8.2 Organization of an Auto Sequence®

An Auto Sequence® is divided into three phases:

- › Before starting the first test the Auto Sequence® view menu is shown (unless it was started directly from the Main Auto Sequences® menu). Parameters and limits of individual measurements can be set in this menu.
- › During the execution phase of an Auto Sequence®, pre-programmed single tests are carried out. The sequence of single tests is controlled by pre-programmed flow commands.
- › After the test sequence is finished the Auto Sequence® result menu is shown. Details of individual tests can be viewed and the results can be saved to Memory organizer.

8.2.1 Auto Sequence® view menu

In the Auto Sequence® view menu, the header and the single tests of selected Auto Sequence® are displayed. The header contains Name, Short code and description of the Auto Sequence®. Before starting the Auto Sequence®, test parameters / limits of individual measurements can be changed.

Note:

- › Once fuse and RCD parameters are changed in active Auto Sequence®, the new settings are distributed through all single tests within the active Auto Sequence® and stored for next use of the same Auto Sequence®.

8.2.1.1 Auto Sequence® view menu (Header is selected)

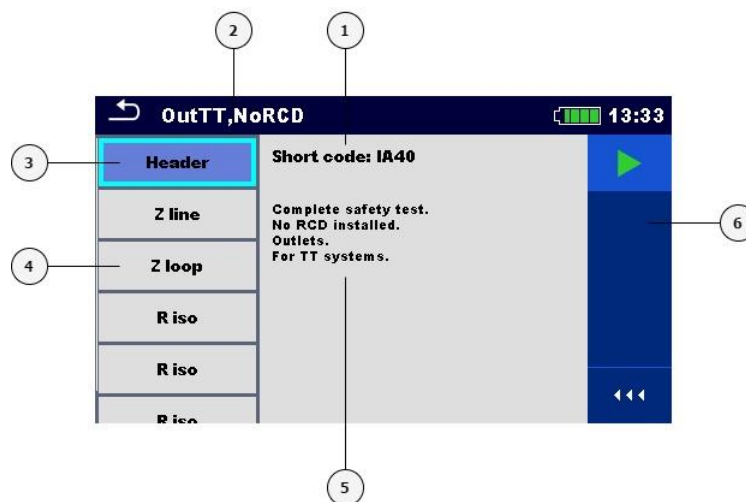

Figure 8.3: Screen organization in Auto Sequence® view menu – Header selected

Legend

1	Short code
2	Auto Sequence® name
3	Header
4	Single tests
5	Description
6	Control panel (available options)

Option



Starts the Auto Sequence®.

8.2.1.2 Auto Sequence® view menu (measurement is selected)

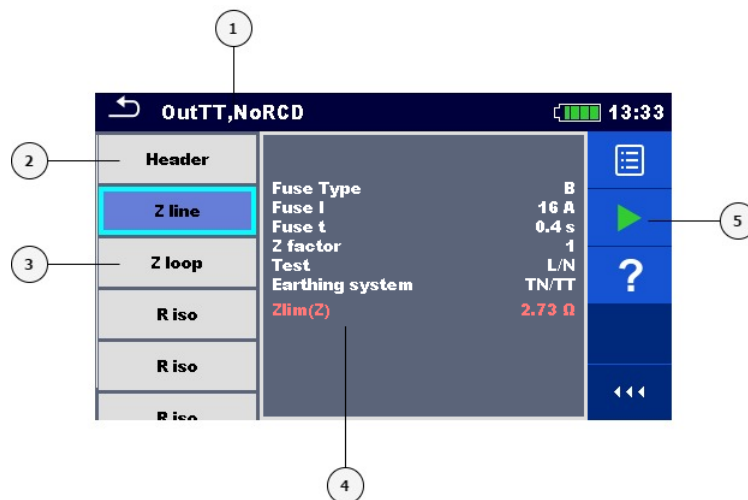

Figure 8.4: Screen organization in Auto Sequence® view menu – measurement selected

Legend

1	Auto Sequence® name
2	Header
3	Single tests
4	Parameters / limits of selected single test
5	Control panel (available options)

Options



Selects single test.



Opens menu for changing parameters and limits of selected measurements.

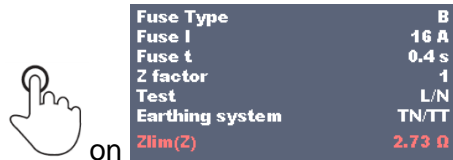

Refer to chapter **6.1.2 Setting parameters, limits and comments** of single tests for more information how to change measurement parameters and limits.

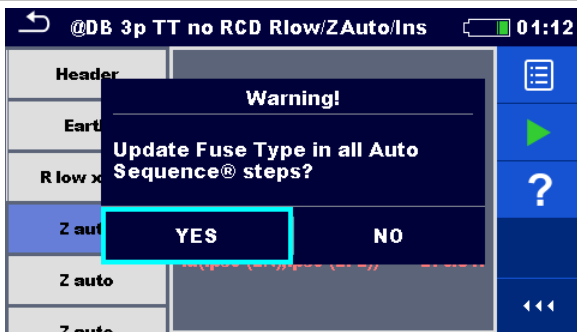

User must decide whether the changes in global parameter(s) apply to all single tests within the selected Auto Sequence® containing the modified parameter(s), or only for the edited one.



Starts the Auto Sequence®.



Opens help screens. Refer to chapter **6.1.8 Help screens** for more information.

8.2.1.3 Indication of Loops



The attached 'x3' at the end of a single test name indicates that a loop of single tests is programmed. This means that the marked single test will be carried out as many times as the number behind the 'x' indicates. It is possible to exit the loop before, at the end of each individual measurement.

8.2.2 Step by step execution of Auto Sequences®

While the Auto Sequence® is running, it is controlled by pre-programmed flow commands. Examples of actions controlled by flow commands are:

- pauses during the Auto Sequence®,
- proceeding of test sequence in regard to measured results,
- etc.

The actual list of flow commands is available on chapter **E.7 – Description of flow commands**.

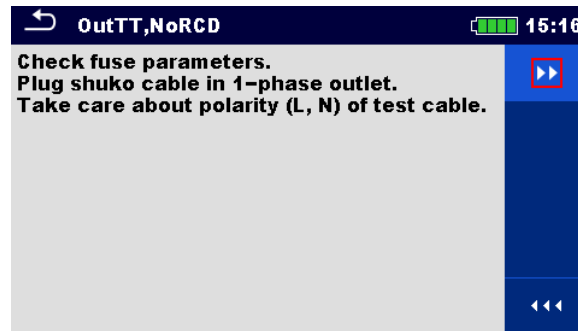

Figure 8.5: Auto Sequence® – Example of a pause with message

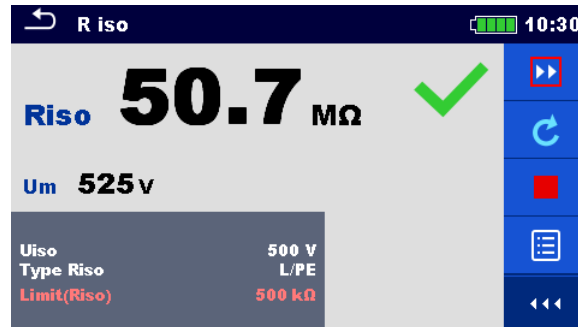

Figure 8.6: Auto Sequence® – Example of a finished measurement with options for proceeding

Options (during execution of an Auto Sequence®)



Proceeds to the next step in the test sequence.



Repeats the measurement.

Displayed result of a single test will not be stored.



Ends the Auto Sequence® and goes to Auto Sequence® result screen.

Refer to chapter **8.2.3 Auto Sequence® result screen** for more information.



Exits the loop of single tests and proceeds to the next step in the Auto Sequence®.

The offered options in the control panel depend on the selected single test, its result and the programmed test flow.

Notes:

- During Auto Sequences® the popup Warning messages are displayed only before the single test inside one Auto Sequence®. This default setting can be changed with appropriate flow command. For more information about programming Auto Sequences® refer to chapter **Appendix E - Programming of Auto Sequences® on Metrel ES Manager**.

8.2.3 Auto Sequence® result screen

After the Auto Sequence® is finished the Auto Sequence® result screen is displayed. On the left side of the display the single tests and their statuses in the Auto Sequence® are shown.

In the middle of the display the header of the Auto Sequence® with Short code and description of the Auto Sequence® is displayed. At the top the overall Auto Sequence® result status is displayed. Refer to chapter **5.1.1 Measurement statuses** for more information.

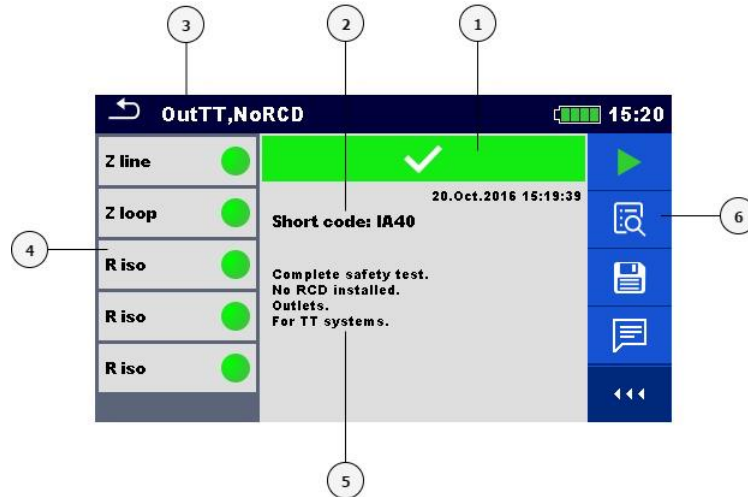

Figure 8.7: Auto Sequence® result screen

Legend

1	Overall PASS / FAIL status
2	Short code
3	Auto Sequence® name
4	Single tests with individual PASS / FAIL statuses
5	Description
6	Control panel (available options)

Options



Starts a new Auto Sequence®.



View results of individual measurements.

The instrument goes to the menu for viewing details of the Auto Sequence®.



Saves the Auto Sequence® results.

A new Auto Sequence® was selected and started from a Structure object in the structure tree:

- › The Auto Sequence® result will be saved under the selected Structure object.

A new Auto Sequence® was started from the Auto Sequence® main menu:

- › Saving under the last selected Structure object will be offered by default. The user can select another Structure object or create a new Structure

object. By pressing  in Memory organizer menu the Auto Sequence® result is saved under selected location.

An empty measurement was selected in structure tree and started:

- The result(s) will be added to the Auto Sequence®. The Auto Sequence® will change its overall status from 'empty' to 'finished'.

An already carried out Auto Sequence® was selected in structure tree, viewed and then restarted:

- A new Auto Sequence® result will be saved under the selected Structure object.



Adds comment to the Auto Sequence®. The instrument opens keypad for entering a comment.

Options (menu for viewing details of Auto Sequence® and single test results)



Details of a selected single test in Auto Sequence® are displayed.



View parameters and limits of selected single test.



Adds comment to the selected single test in Auto Sequence®. The instrument opens keypad for entering a comment.



Figure 8.8: Menu for viewing details of Auto Sequence® and single test results

8.2.4 Auto Sequence® memory screen

In Auto Sequence® memory screen details of the Auto Sequence® results can be viewed and a new Auto Sequence® can be restarted.

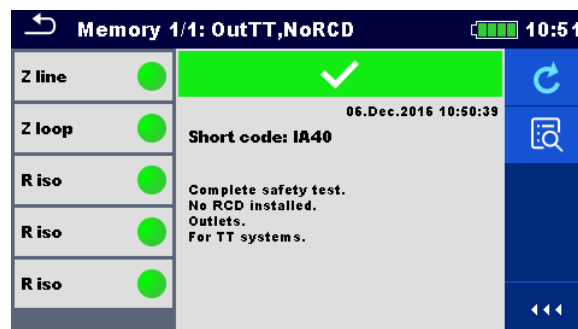

Figure 8.9: Auto Sequence® memory screen

Options



Retest the Auto Sequence®.
Enters menu for a new Auto Sequence®.



Enters menu for viewing details of the Auto Sequence®. Refer to chapter **8.2.3**
Auto Sequence® result screen for more information.

9 Communication

The instrument can communicate with the Metrel ES Manager PC software and aMESM android application. The following action is supported:

- › Saved results and Tree structure from Memory organizer can be downloaded and stored to a PC or android device.
- › Tree structure from Metrel ES Manager PC software or aMESM android application can be uploaded to the instrument.
- › Custom Auto Sequences® can be uploaded to the instrument or downloaded and stored to a PC.

Metrel ES Manager is a PC software running on Windows 8.1 and Windows 10.

There are three communication interfaces available on the instrument:

- › RS-232,
- › USB,
- › Bluetooth.

Instrument can also communicate to various external devices (test adapters, scanners ...).

9.1 USB and RS232 communication

The instrument automatically selects the communication mode according to detected interface. USB interface has priority.

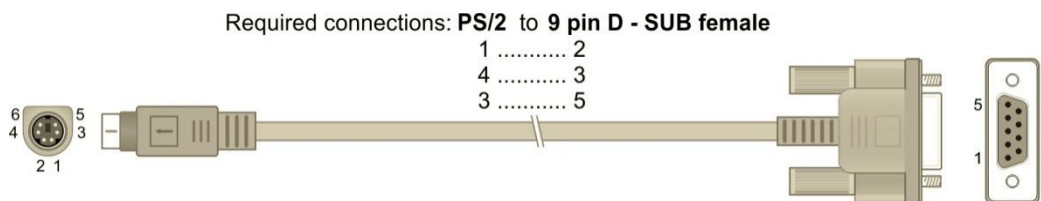

Figure 9.1: Interface connection for data transfer over PC COM port

How to establish an USB or RS-232 link

- › RS-232 communication: connect a PC COM port to the instrument PS/2 connector using the PS/2 - RS232 serial communication cable;
- › USB communication: connect a PC USB port to the instrument USB connector using the USB interface cable.
- › Switch on the PC and the instrument.
- › Run the *Metrel ES Manager* software.
- › Select communication port (COM port for USB communication is identified as 'Measurement Instrument USB VCom Port').
- › The instrument is prepared to communicate with the PC.

9.2 Bluetooth communication with Android devices

The internal Bluetooth module enables easy communication via Bluetooth with Android devices.

How to configure a Bluetooth link between instrument and PC

- › Switch on the instrument.
- › On PC configure a Standard Serial Port to enable communication over Bluetooth link between instrument and PC. Usually no code for pairing the devices is needed.
- › Run the *Metrel ES Manager* software.

- › Select configured communication port.
- › The instrument is prepared to communicate with the PC.

How to configure a Bluetooth link between instrument and an Android device

- › Switch on the instrument.
- › Some Android applications automatically carry out the setup of a Bluetooth connection. It is preferred to use this option if it exists. This option is supported by Metrel's Android applications.
If this option is not supported by the selected Android application then configure a Bluetooth link via Android device's Bluetooth configuration tool. Usually no code for pairing the devices is needed.
- › The instrument and Android device are ready to communicate.

Notes

- › Sometimes there will be a demand from the PC or Android device to enter the code. Enter code '1234' to correctly configure the Bluetooth link.
- › The name of correctly configured Bluetooth device must consist of the instrument type plus serial number, e.g. *MI 3155-12240429I*. If the Bluetooth module got another name, the configuration must be repeated.
- › In case of serious troubles with the Bluetooth communication it is possible to reinitialize the internal Bluetooth module. The initialization is carried out during the Initial settings procedure. In case of a successful initialization "INITIALIZING... OK!" is displayed at the end of the procedure. See chapter **4.6.10 Initial Settings**.
- › Metrel android application aMESM is available for download from Google play store:



9.3 Communication with adapters

EurotestXD can communicate with Metrel test and measurement adapters through wired RS232 port or wireless Bluetooth communication port.

Adapter can be selected from the list of adapters from *General Settings / Settings / Adapters* section menu, see **Figure 9.2** below.

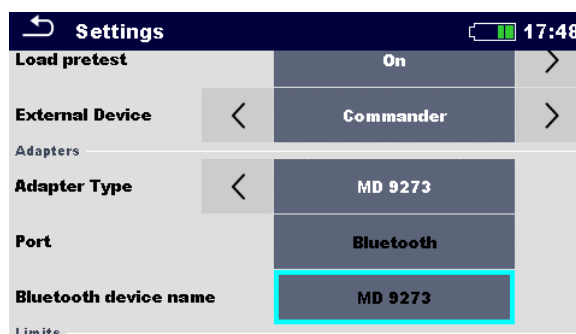



Figure 9.2: Adapters section menu

When adapter is selected from the list, supported communication port is automatically offered. To establish Bluetooth communication, adapter must be paired with EurotestXD.

Procedure:

1. **Adapter:** switch it ON and select BT mode, if not already automatically selected.
2. **EurotestXD:** Open General Settings / Settings menu and navigate to the Adapters section.
3. **Adapter type:** select adapter by using left / right arrows or tap on the field and select it from the list of adapters
4. **Port:** Bluetooth or RS232, which one is supported by the adapter, is automatically offered. Connect serial cable or proceed with pairing procedure
5. **Bluetooth device name:** select field and instrument start searching for Bluetooth devices; when finished, list of available devices is presented on the screen
6. **Select Adapter name from the list:** pairing procedure is finished.

When test supported by the adapter is selected on EurotestXD, active BT communication is indicated with sign  on the right – top of the screen.

Note:

Pairing between same Metrel adapter and same EurotestXD is necessary only when adapter is first time used. If communication is not established when supported test is selected, adapter is probably switched OFF or Bluetooth link is out of range.

9.4 Bluetooth and RS-232 communication with scanners

EurotestXD instrument can communicate with supported Bluetooth and serial scanners. Serial scanner should be connected to the instrument via PS/2 serial port. Contact Metrel or your distributor which external devices and functionalities are supported. See chapter **4.6.9 Devices** for details how to set the external Bluetooth or serial device.

10 Upgrading the instrument

The instrument can be upgraded from a PC via the RS232 or USB communication port. This enables to keep the instrument up to date even if the standards or regulations change. The firmware upgrade requires internet access and can be carried out from the **Metrel ES Manager** software with a help of special upgrading software – **FlashMe** which will guide you through the upgrading procedure. For more information refer to Metrel ES Manager Help file.

11 Maintenance

Unauthorized persons are not allowed to open the EurotestXD instrument. There are no user replaceable components inside the instrument, except the battery and fuses under back cover.



Figure 11.1: Position of screws to open battery / fuse compartment

11.1 Fuse replacement

There are three fuses under back cover of the EurotestXD instrument.

F1	M 0.315 A / 250 V, 20×5 mm
	This fuse protects internal circuitry for continuity functions if test probes are connected to the mains supply voltage by mistake during measurement.
F2, F3	F 5 A / 500 V, 32×6.3 mm (breaking capacity: 50 kA)
	General input protection fuses of test terminals L/L1 and N/L2.

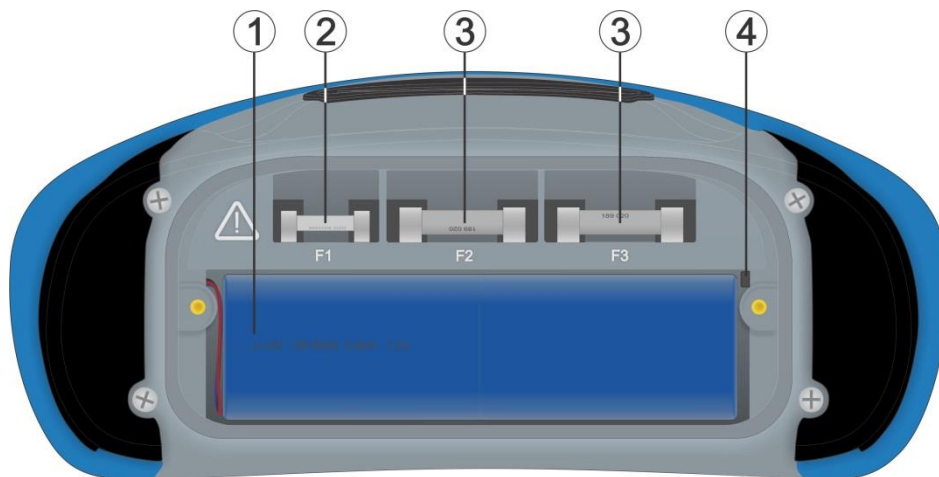

Figure 11.2: Fuses

Warnings:

- Disconnect all measuring accessory and switch off the instrument before opening battery / fuse compartment cover, hazardous voltage inside!
- Replace blown fuse with original type only, otherwise the instrument or accessory may be damaged and / or operator’s safety impaired!

11.2 Battery pack insertion / replacement

Procedure:

<p>①</p>	<p>Remove the battery pack from battery compartment.</p>	
<p>②</p>	<p>Remove foam if were inserted under the battery pack.</p>	
<p>③</p>	<p>Press to unlock the connector (1) and pull the wires (2) to disconnect the battery pack from the instrument.</p>	
<p>①</p>	<p>Connect the new battery pack to the instrument.</p>	
<p>②</p>	<p>For standard capacity pack use a foam (2) to fill empty space.</p>	
<p>③</p>	<p>Insert the battery pack in battery compartment and close the battery / fuse compartment cover.</p> <p>Note:</p>	

	When placing high-capacity battery pack make sure that protection circuit module of the battery pack is placed at top inner side of the compartment.	
--	--	--

Warnings:

- › Disconnect all measuring accessory and switch off the instrument before opening battery / fuse compartment cover, hazardous voltage inside!
- › Replace battery pack with original type only, otherwise the instrument may be damaged and / or operator's safety impaired!
- › Ensure batteries are used and disposed of in accordance with Manufacturers guidelines and in accordance with Local and National Authority guidelines.

11.3 Cleaning

No special maintenance is required for the housing. To clean the surface of the instrument or accessory use a soft cloth slightly moistened with soapy water or alcohol. Then leave the instrument or accessory to dry totally before use.

Warnings:

- › Do not use liquids based on petrol or hydrocarbons!
- › Do not spill cleaning liquid over the instrument!

11.4 Periodic calibration

It is essential that the test instrument is regularly calibrated in order that the technical specification listed in this manual is guaranteed. We recommend an annual calibration. Only an authorized technical person can do the calibration. Please contact your dealer for further information.

11.5 Service

For repairs under warranty, or at any other time, please contact your distributor.

12 Technical specifications

12.1 R iso, R iso all – Insulation resistance

Uiso: 50 V, 100 V and 250 V (R iso, R iso all)

Riso – Insulation resistance (R iso)

R L-N, R L-PE, R N-PE – Insulation resistance (R iso all)

Measuring range according to EN 61557 is 0.15 M Ω ... 199.9 M Ω .

Measuring range (M Ω)	Resolution (M Ω)	Accuracy
0.00 ... 19.99	0.01	$\pm(5\% \text{ of reading} + 3 \text{ digits})$
20.0 ... 99.9	0.1	$\pm(10\% \text{ of reading})$
100.0 ... 199.9		$\pm(20\% \text{ of reading})$

Uiso: 500 V (R iso, R iso all)

Riso – Insulation resistance (R iso)

R L-N, R L-PE, R N-PE – Insulation resistance (R iso all)

Measuring range according to EN 61557 is 0.15 M Ω ... 999 M Ω .

Measuring range (M Ω)	Resolution (M Ω)	Accuracy
0.00 ... 19.99	0.01	$\pm(5\% \text{ of reading} + 3 \text{ digits})$
20.0 ... 199.9	0.1	$\pm(5\% \text{ of reading})$
200 ... 999	1	$\pm(10\% \text{ of reading})$

Uiso: 1000 V (R iso, R iso all)

Riso – Insulation resistance (R iso)

R L-N, R L-PE, R N-PE – Insulation resistance (R iso all)

Measuring range according to EN 61557 is 0.15 M Ω ... 199.9 M Ω .

Measuring range (M Ω)	Resolution (M Ω)	Accuracy
0.00 ... 19.99	0.01	$\pm(5\% \text{ of reading} + 3 \text{ digits})$
20.0 ... 199.9	0.1	$\pm(5\% \text{ of reading})$
200 ... 999	1	indicative

Uiso: 2500V (R iso)

Riso – Insulation resistance

Measuring range (Ω)	Resolution (Ω)	Accuracy
0.00 M ... 19.99 M	0.01 M	$\pm(5\% \text{ of reading} + 3 \text{ digits})$
20.0 M ... 199.9 M	0.1 M	$\pm(5\% \text{ of reading})$
200 M ... 999 M	1 M	$\pm(10\% \text{ of reading})$
1.00 G ... 19.99 G	0.01 G	$\pm(10\% \text{ of reading})$

Um – Voltage (Riso, Riso all)

Measuring range (V)	Resolution (V)	Accuracy
0 ... 2700	1	$\pm(3\% \text{ of reading} + 3 \text{ digits})$

Nominal voltages Uiso 50 V_{DC}, 100 V_{DC}, 250 V_{DC}, 500 V_{DC}, 1000 V_{DC},
2500 V_{DC}

Open circuit voltage -0 % / +20 % of nominal voltage

Measuring current min. 1 mA at $R_N = U_N \times 1 \text{ k}\Omega/\text{V}$

Short circuit current max. 3 mA

Load pretest voltage < 20 V_{AC}, 125 Hz

Load pretest warning < 50 k Ω

The number of possible tests

(R iso, Riso all) up to 1000, with a fully charged battery (type: 18650T22A2S2P)
up to 2000, with a fully charged battery (type: 18650T22A2S4P)

Auto discharge after test.

Specified accuracy is valid if 3-wire test lead is used while it is valid up to 100 M Ω if Tip commander is used.

Specified accuracy is valid up to 100 M Ω if relative humidity is > 85 %.

In case the instrument gets moistened, the results could be impaired. In such case, it is recommended to dry the instrument and accessories for at least 24 hours.

The error in operating conditions could be at most the error for reference conditions (specified in the manual for each function) ± 5 % of measured value.

12.2 Diagnostic test

Uiso: 500V, 1000 V, 2500 V

DAR – Dielectric absorption ratio

Measuring range	Resolution	Accuracy
0.01 ... 9.99	0.01	$\pm(5$ % of reading + 2 digits)
10.0 ... 100.0	0.1	$\pm(5$ % of reading)

PI – Polarization index

Measuring range	Resolution	Accuracy
0.01 ... 9.99	0.01	$\pm(5$ % of reading + 2 digits)
10.0 ... 100.0	0.1	$\pm(5$ % of reading)

For Riso, R60 and Um sub-results technical specifications defined in chapter 12.1 R iso, R iso all – Insulation resistance apply.

12.3 R low, R low 4W – Resistance of earth connection and equipotential bonding

Measuring range according to EN 61557 is 0.16 Ω ... 1999 Ω .

R – Resistance

Measuring range (Ω)	Resolution (Ω)	Accuracy
0.00 ... 19.99	0.01	$\pm(3$ % of reading + 3 digits)
20.0 ... 199.9	0.1	$\pm(5$ % of reading)
200 ... 1999	1	

R+, R – Resistance

Measuring range (Ω)	Resolution (Ω)	Accuracy
0.0 ... 199.9	0.1	$\pm(5$ % of reading + 5 digits)
200 ... 1999	1	

Open-circuit voltage.....6.5 VDC ... 18 VDC

Measuring current.....min. 200 mA into load resistance of 2 Ω

Test lead compensation (Rlow)up to 5 Ω
 The number of possible tests:
 (Rlow (Current = standard), Rlow 4W)up to 1700, with a fully charged battery (type: 18650T22A2S2P)
 up to 3400, with a fully charged battery (type: 18650T22A2S4P)
 Rlow (Current = ramp)up to 1000, with a fully charged battery (type: 18650T22A2S2P)
 up to 2000, with a fully charged battery (type: 18650T22A2S4P)

Automatic polarity reversal of the test voltage.

12.4 Continuity – Continuous resistance measurement with low current

R – Continuity resistance

Measuring range (Ω)	Resolution (Ω)	Accuracy
0.0 ... 19.9	0.1	±(5 % of reading + 3 digits)
20 ... 1999	1	

Open-circuit voltage.....6.5 VDC ... 18 VDC
 Short-circuit currentmax. 8.5 mA
 Test lead compensation.....up to 5 Ω

12.5 Ring Continuity

Measuring range according to EN 61557 is 0.16 Ω ... 1999 Ω.

(r1,r2,rN), (R1+RN,R1+R2)

Measuring range (Ω)	Resolution (Ω)	Accuracy
0.00 ... 19.99	0.01	±(3 % of reading + 3 digits)
20.0 ... 199.9	0.1	±(5 % of reading)
200 ... 1999	1	

Open-circuit voltage.....6.5 VDC ... 18 VDC
 Measuring current.....min. 200 mA into load resistance of 2 Ω

12.6 RCD testing

12.6.1 General data

Nominal residual current (A,AC) 10 mA, 15 mA, 30 mA, 100 mA, 300 mA, 500 mA, 1000 mA

Nominal residual current accuracy -0 / +0.1·I_Δ; I_Δ = I_{ΔN}, 2×I_{ΔN}, 5×I_{ΔN}
 -0.1·I_Δ / +0; I_Δ = 0.5×I_{ΔN}
 AS/NZS 3017 selected: ± 5 %

Sensitivity parameter supportedPRCD, PRCD-3p, PRCD-2p, PRCD-S+, PRCD-K

Nominal residual current accuracy by using parameter Sensitivity:

Sensitivity: standard.....-0 / +0.1·I_Δ; I_Δ = I_{ΔN}, 2×I_{ΔN}, 5×I_{ΔN}
 -0.1·I_Δ / +0; I_Δ = 0.5×I_{ΔN}

Sensitivity: Ipe monitoring.....-0 / +0.1·I_Δ; I_Δ = 0.5×I_{ΔN}, 2×0.5×I_{ΔN}, 5×0.5×I_{ΔN}
 -0.1·I_Δ / +0; I_Δ = 0.5×0.5×I_{ΔN}

AS/NZS 3017 selected: ± 5 %

Test current shape.....Sine-wave (AC), pulsed (A, F), smooth DC (B, B+)

DC offset for pulsed test current< 2 mA (typical)

RCD type.....(non-delayed), S (time-delayed), PRCD, PRCD-2p, PRCD-3p, PRCD-S, PRCD-S+, PRCD-K, EV RCD, EV RCM, MI RCD

Test current starting polarity 0° or 180°

Voltage range 93 V ... 134 V (16 Hz ... 400 Hz)
 185 V ... 266 V (16 Hz ... 400 Hz)

RCD test current in relation to RCD type, nominal RCD current and multiplication factor

I _{ΔN} (mA)	I _{ΔN} × 1/2 (mA)			I _{ΔN} × 1 (mA)			I _{ΔN} × 2 (mA)			I _{ΔN} × 5 (mA)			RCD I _Δ		
	AC	A, F	B, B+	AC	A, F	B, B+	AC	A, F	B, B+	AC	A, F	B, B+	AC	A, F	B, B+
10	5	3.5	5	10	20	20	20	40	40	50	100	100	✓	✓	✓
15	7.5	5.3	7.5	15	30	30	30	60	60	75	150	150	✓	✓	✓
30	15	10.5	15	30	42	60	60	84	120	150	212	300	✓	✓	✓
100	50	35	50	100	141	200	200	282	400	500	707	1000	✓	✓	✓
300	150	105	150	300	424	600	600	848	×	1500	×	×	✓	✓	✓
500	250	175	250	500	707	1000	1000	1410	×	2500	×	×	✓	✓	✓
1000	500	350	500	1000	1410	×	2000	×	×	×	×	×	✓	✓	×

×not applicable
 ✓applicable

AC type.....sine wave test current
 A, F types.....pulsed current
 B, B+ types.....smooth DC current

RCD test current in relation to MI / EV RCD type and multiplication factor

	$I_{\Delta N} \times 1/2$ (mA)	$I_{\Delta N} \times 1$ (mA)	$I_{\Delta N} \times 2$ (mA)	$I_{\Delta N} \times 5$ (mA)	$I_{\Delta N} \times 10$ (mA)	$I_{\Delta N} \times 33.33$ (mA)	$I_{\Delta N} \times 50$ (mA)	RCD I_{Δ}	
$I_{\Delta N}$ (mA)	MI / EV a.c., d.c.	MI / EV a.c., d.c.	MI / EV a.c.	MI / EV a.c.	MI / EV d.c.	MI / EV d.c. (IEC 62955)	MI / EV d.c. (IEC 62752)	MI / EV a.c.	MI / EV d.c.
30 a.c.	15	30	60	150	x	x	x	✓	x
6 d.c.	3	6	x	x	60	200	300	x	✓

xnot applicable

✓applicable

MI / EV type (a.c. part)sine wave test current

MI / EV type (d.c. part)smooth DC current

12.6.2 RCD U_c – Contact voltage

Measuring range according to EN 61557 is 20.0 V ... 31.0 V for limit contact voltage 25 V

Measuring range according to EN 61557 is 20.0 V ... 62.0 V for limit contact voltage 50 V

 U_c – Contact voltage, $U_c(P)$ – Contact voltage, external probe

Measuring range (V)	Resolution (V)	Accuracy
0.0 ... 19.9	0.1	(-0 % / +15 %) of reading \pm 10 digits
20.0 ... 99.9	0.1	(-0 % / +15 %) of reading

The accuracy is valid if mains voltage is stable during the measurement and PE terminal is free of interfering voltages. Specified accuracy is valid for complete operating range.

Test current max. $0.5 \times I_{\Delta N}$

Limit contact voltage (U_c , $U_c(P)$) Custom, 12 V, 25 V, 50 V

12.6.3 RCD t – Trip-out time

Complete measurement range corresponds to EN 61557 requirements.

Maximum measuring times set according to selected reference for RCD testing.

 $t_{\Delta N}$ – Trip-out time

Measuring range (ms)	Resolution (ms)	Accuracy
0.0 ... 40.0	0.1	± 1 ms
0.0 ... max. time*	0.1	± 3 ms

* For max. time see normative references in chapter **4.6.8.2 RCD standard**. This specification applies to max. time >40 ms.

Test current $\frac{1}{2} \times I_{\Delta N}$, $I_{\Delta N}$, $2 \times I_{\Delta N}$, $5 \times I_{\Delta N}$

$5 \times I_{\Delta N}$ is not available for $I_{\Delta N}=1000$ mA (RCD type AC) or $I_{\Delta N} \geq 300$ mA (RCD types A, F, B, B+).

$2 \times I_{\Delta N}$ is not available for $I_{\Delta N}=1000$ mA (RCD types A, F) or $I_{\Delta N} \geq 300$ mA (RCD types B, B+).

$1 \times I_{\Delta N}$ is not available for $I_{\Delta N}=1000$ mA (RCD types B, B+).

Specified accuracy is valid for complete operating range.

12.6.4 RCD I – Trip-out current

Complete measurement range corresponds to EN 61557 requirements.

I Δ – Trip-out current

Measuring range	Resolution I Δ	Accuracy
0.2×I Δ N ... 1.1×I Δ N (AC type)	0.05×I Δ N	±0.1×I Δ N
0.2×I Δ N ... 1.0×I Δ N (IEC 62752: EV RCD, EV RCM, MI RCD (a.c. part))	0.05×I Δ N	±0.1×I Δ N
0.2×I Δ N,d.c. ... 1.0×I Δ N,d.c. (IEC 62752: EV RCD, EV RCM, MI RCD (d.c. part))	0.05×I Δ N,d.c.	±0.1×I Δ N,d.c.
0.2×I Δ N ... 1.0×I Δ N (IEC 62955: EV RCD, EV RCM, MI RCD (a.c. part))	0.05×I Δ N	±0.1×I Δ N
0.2×I Δ N,d.c. ... 1.0×I Δ N,d.c. (IEC 62955: EV RCD, EV RCM, MI RCD (d.c. part))	0.05×I Δ N,d.c.	±0.1×I Δ N,d.c.
0.2×I Δ N ... 1.5×I Δ N (A type, I Δ N≥30 mA)	0.05×I Δ N	±0.1×I Δ N
0.2×I Δ N ... 2.2×I Δ N (A type, I Δ N<30 mA)	0.05×I Δ N	±0.1×I Δ N
0.2×I Δ N ... 2.2×I Δ N (B type)	0.05×I Δ N	±0.1×I Δ N

t I Δ – Trip out-time

Measuring range (ms)	Resolution (ms)	Accuracy
0 ... 300	1	±3 ms

Uc, Uc I Δ – Contact voltage

Measuring range (V)	Resolution (V)	Accuracy
0.0 ... 19.9	0.1	(-0 % / +15 %) of reading ± 10 digits
20.0 ... 99.9	0.1	(-0 % / +15 %) of reading

Limit contact voltage (Uc, Uc I Δ)..... Custom, 12 V, 25 V, 50 V

The accuracy is valid if mains voltage is stable during the measurement and PE terminal is free of interfering voltages. Specified accuracy is valid for complete operating range.

Trip-out measurement is not available for I Δ N=1000 mA (RCD types B, B+).

12.6.5 RCD Auto

For technical specification refer to chapter **12.6 RCD testing** for technical specification of individual RCD tests.

12.7 Z loop, Z loop 4W – Fault loop impedance and prospective fault current

Z – Fault loop impedance

Measuring range according to EN 61557 is 0.12 Ω ... 9.99 k Ω .

Measuring range (Ω)	Resolution (Ω)	Accuracy
0.00 ... 9.99	0.01	±(3 % of reading + 3 digits)
10.0 ... 99.9	0.1	

100 ... 999	1	± 10 % of reading
1.00 k ... 9.99 k	10	

Ipsc – Prospective fault current

Measuring range (A)	Resolution (A)	Accuracy
0.00 ... 9.99	0.01	Consider accuracy of fault loop resistance measurement
10.0 ... 99.9	0.1	
100 ... 999	1	
1.00 k ... 9.99 k	10	
10.0 k ... 23.0 k	100	

U_{lpe} – Voltage

Measuring range (V)	Resolution (V)	Accuracy
0 ... 550	1	±(2 % of reading + 2 digits)

U_{c(P)} – Contact voltage at Ipsc, external probe

Measuring range (V)	Resolution (V)	Accuracy
0.0 ... 99.9	0.1	(-0 % / +15 %) of reading ± 0.02 Ω × I _{PSC}

The accuracy is valid if mains voltage is stable during the measurement.

Test current (at 230 V)..... 20 A (10 ms)

Nominal voltage range.....93 V ... 134 V (16 Hz ... 400 Hz)

185 V ... 266 V (16 Hz ... 400 Hz)

R and X_L values are indicative.

12.8 Zs rcd – Fault loop impedance and prospective fault current in system with RCD

Z – Fault loop impedance

Measuring range according to EN 61557 is 0.46 Ω ... 9.99 k Ω for I test = standard and 0.48 Ω ... 9.99 k Ω for I test = low.

Measuring range (Ω)	Resolution (Ω)	Accuracy I test = standard	Accuracy I test = low
0.00 ... 9.99	0.01	$\pm(5\% \text{ of reading} + 10 \text{ digits})$	$\pm(5\% \text{ of reading} + 12 \text{ digits})$
10.0 ... 99.9	0.1		
100 ... 999	1	$\pm 10\% \text{ of reading}$	$\pm 10\% \text{ of reading}$
1.00 k ... 9.99 k	10		

Accuracy may be impaired in case of heavy noise on mains voltage.

Ipsc – Prospective fault current

Measuring range (A)	Resolution (A)	Accuracy
0.00 ... 9.99	0.01	Consider accuracy of fault loop resistance measurement
10.0 ... 99.9	0.1	
100 ... 999	1	
1.00 k ... 9.99 k	10	
10.0 k ... 23.0 k	100	

UIpe – Voltage

Measuring range (V)	Resolution (V)	Accuracy
0 ... 550	1	$\pm(2\% \text{ of reading} + 2 \text{ digits})$

Uc(P) – Contact voltage at Ipsc (Protection = TN), external probe

Measuring range (V)	Resolution (V)	Accuracy
0.0 ... 99.9	0.1	$(-0\% / +15\%) \text{ of reading} \pm 0.02 \Omega \times I_{PSC}$

Uc(P) – Contact voltage at IAN (Protection = TT rcd), external probe

Measuring range (V)	Resolution (V)	Accuracy
0.0 ... 99.9	0.1	$(-0\% / +15\%) \text{ of reading} \pm 10 \text{ digits}$

Uc – Contact voltage

Refer to chapter **12.6.2 RCD Uc – Contact voltage** for detailed technical specification.

Nominal voltage range.....93 V ... 134 V (16 Hz ... 400 Hz)
185 V ... 266 V (16 Hz ... 400 Hz)

No trip out of RCD.

R, X_L values are indicative.

12.9 Z loop mΩ – High precision fault loop impedance and prospective fault current

This test is performed in combination with an external test adapter / instrument.

For technical specification refer to **A 1143 Euro Z 290 A**, **MI 3143 Euro Z 440 V** and **MI 3144 Euro Z 800 V Instruction manual**.

12.10 U touch – Touch voltage (MI 3143 and MI 3144)

This test is performed in combination with an external test adapter / instrument.

For technical specification refer to **MI 3143 Euro Z 440 V** and **MI 3144 Euro Z 800 V Instruction manual**.

12.11 Z line, Z line 4W – Line impedance and prospective short-circuit current

Z – Line impedance

Measuring range according to EN 61557 is 0.12 Ω ... 9.99 kΩ.

Measuring range (Ω)	Resolution (Ω)	Accuracy
0.00 ... 9.99	0.01	±(3 % of reading + 3 digits)
10.0 ... 99.9	0.1	
100 ... 999	1	± 10 % of reading
1.00 k ... 9.99 k	10	

Ipsc – prospective short-circuit current

I_{max} – Maximal single-phase prospective short-circuit current

I_{max2p} – Maximal two-phases prospective short-circuit current

I_{max3p} – Maximal three-phases prospective short-circuit current

Measuring range (A)	Resolution (A)	Accuracy
0.00 ... 0.99	0.01	Consider accuracy of line resistance measurement
1.0 ... 99.9	0.1	
100 ... 999	1	
1.00 k ... 99.99 k	10	
100 k ... 199 k	1000	

U_{ln} – Voltage

Measuring range (V)	Resolution (V)	Accuracy
0 ... 550	1	±(2 % of reading + 2 digits)

Test current (at 230 V) 20 A (10 ms)

Nominal voltage range 93 V ... 134 V (16 Hz ... 400 Hz)

185 V ... 266 V (16 Hz ... 400 Hz)

321 V ... 485 V (16 Hz ... 400 Hz)

R, X_L, I_{min}, I_{min2p}, I_{min3p} values are indicative.

12.12 Z line mΩ – High precision line impedance and prospective short-circuit current

This test is performed in combination with an external test adapter / instrument.

For technical specification refer to **A 1143 Euro Z 290 A**, **MI 3143 Euro Z 440 V** and **MI 3144 Euro Z 800 V Instruction manual**.

12.13 Voltage Drop

ΔU – Voltage drop

Measuring range (%)	Resolution (%)	Accuracy
0.0 ... 99.9	0.1	Consider accuracy of line impedance measurement(s)*

U_{ln}, I_{psc}, Z_{ref}, Z

Refer to chapter **12.11 Z line, Z line 4W – Line impedance and prospective short-circuit current** for technical specification.

Z_{REF} measuring range 0.00 Ω ... 20.0 Ω

Test current (at 230 V) 20 A (10 ms)

Nominal voltage range 93 V ... 134 V (16 Hz ... 400 Hz)
 185 V ... 266 V (16 Hz ... 400 Hz)
 321 V ... 485 V (16 Hz ... 400 Hz)

*See chapter **7.19 Voltage Drop** for more information about calculation of voltage drop result.

12.14 High current (MI 3143 and MI 3144)

This test is performed in combination with an external test adapter / instrument.

For technical specification refer to **MI 3143 Euro Z 440 V** and **MI 3144 Euro Z 800 V Instruction manual**.

12.15 Z auto, AUTO TT, AUTO TN, AUTO TN (RCD), AUTO IT

Refer to following chapters for detailed technical specification:

12.6.2 RCD U_c – Contact voltage,

12.7 Z loop, Z loop 4W – Fault loop impedance and prospective fault current,

12.8 Z_{s rcd} – Fault loop impedance and prospective fault current in system with RCD

12.11 Z line, Z line 4W – Line impedance and prospective short-circuit current,

12.13 Voltage Drop,

12.16 Rpe – PE conductor resistance,

12.26 ISFL – First fault leakage current and

12.27 IMD.

12.16 Rpe – PE conductor resistance

RCD: No

R – PE conductor resistance

Measuring range (Ω)	Resolution (Ω)	Accuracy
0.00 ... 19.99	0.01	$\pm(5\% \text{ of reading} + 5 \text{ digits})$
20.0 ... 99.9	0.1	
100.0 ... 199.9	0.1	$\pm 10\% \text{ of reading}$
200 ... 1999	1	

Measuring current.....min. 200 mA into PE resistance of 2 Ω

RCD: Yes, no trip out of RCD

R – PE conductor resistance

Measuring range (Ω)	Resolution (Ω)	Accuracy
0.00 ... 19.99	0.01	$\pm(5\% \text{ of reading} + 10 \text{ digits})$
20.0 ... 99.9	0.1	
100.0 ... 199.9	0.1	$\pm 10\% \text{ of reading}$
200 ... 1999	1	

Accuracy may be impaired in case of heavy noise on mains voltage.

Measuring current..... < 15 mA

Nominal voltage range.....93 V ... 134 V (16 Hz ... 400 Hz)

185 V ... 266 V (16 Hz ... 400 Hz)

12.17 Earth – Earth resistance (3-wire measurement)

Re – Earth resistance

Measuring range according to EN61557-5 is 0.20 Ω ... 1999 Ω .

Measuring range (Ω)	Resolution (Ω)	Accuracy
0.00 ... 19.99	0.01	$\pm(5\% \text{ of reading} + 5 \text{ digits})$
20.0 ... 199.9	0.1	
200 ... 9999	1	

Max. auxiliary earth electrode resistance R_C 100 $\times R_E$ or 50 k Ω (whichever is lower)

Max. probe resistance R_P 100 $\times R_E$ or 50 k Ω (whichever is lower)

R_C and R_P values are indicative.

Additional probe resistance error at R_{Cmax} or R_{Pmax} .. $\pm(10\% \text{ of reading} + 10 \text{ digits})$

Additional error at 3 V voltage noise (50 Hz) $\pm(5\% \text{ of reading} + 10 \text{ digits})$

Open circuit voltage < 30 VAC

Short circuit current < 30 mA

Test voltage frequency 125 Hz

Test voltage shape sine wave

Noise voltage indication threshold 1 V (< 50 Ω , worst case)

Automatic measurement of auxiliary electrode resistance and probe resistance.

Automatic measurement of voltage noise.

12.18 Earth 2 clamp – Contactless earthing resistance measurement (with two current clamps)

Re – Earth resistance

Measuring range (Ω)	Resolution (Ω)	Accuracy ^{*)}
0.00 ... 19.99	0.01	$\pm(10\% \text{ of reading} + 10 \text{ digits})$
20.0 ... 30.0	0.1	$\pm(20\% \text{ of reading})$
30.1 ... 39.9	0.1	$\pm(30\% \text{ of reading})$

^{*)} Distance between current clamps > 30 cm.

Additional error at 3 V voltage noise (50 Hz) $\pm 10\% \text{ of reading}$

Test voltage frequency 125 Hz

Noise current indication yes

Low clamp current indication yes

Additional clamp error has to be considered.

12.19 Ro – Specific earth resistance

ρ – Specific earth resistance

Measuring range (Ωm)	Resolution (Ωm)	Accuracy
0.0 ... 99.9	0.1	See accuracy note
100 ... 999	1	
1.00 k ... 9.99 k	0.01 k	
10.0 k ... 99.9 k	0.1 k	
100 k ... 9999 k	1 k	

ρ – Specific earth resistance

Measuring range (Ωft)	Resolution (Ωft)	Accuracy
0.0 ... 99.9	0.1	See accuracy note
100 ... 999	1	
1.00 k ... 9.99 k	0.01 k	
10.0 k ... 99.9 k	0.1 k	
100 k ... 9999 k	1 k	

R_C and R_P values are indicative.

Principle:

$$\rho = 2 \cdot \pi \cdot d \cdot R_e,$$

where R_e is a measured resistance in 4-wire method and d is distance between the probes.

Accuracy note:

Accuracy of the specific earth resistance result depends on measured earth resistance R_e as follows:

R_e – Earth resistance

Measuring range (Ω)	Accuracy
1.00 ... 1999	$\pm 5\%$ of measured value
2000 ... 19.99 k	$\pm 10\%$ of measured value
>20 k	$\pm 20\%$ of measured value

Additional error:

See *Earth resistance three-wire method*.

12.20 Voltage, frequency, and phase rotation

12.20.1 Phase rotation

Nominal system voltage range..... 100 V_{AC} ... 550 V_{AC}
 Nominal frequency range..... 14 Hz ... 500 Hz
 Result displayed 1.2.3 or 3.2.1

12.20.2 Voltage / Online terminal voltage monitor

Measuring range (V)	Resolution (V)	Accuracy
0 ... 550	1	±(2 % of reading + 2 digits)

Result type True r.m.s. (TRMS)
 Nominal frequency range..... 0 Hz, 14 Hz ... 500 Hz

12.20.3 Frequency

Measuring range (Hz)	Resolution (Hz)	Accuracy
0.00 ... 9.99	0.01	±(0.2 % of reading + 1 digit)
10.0 ... 499.9	0.1	

Nominal voltage range..... 20 V ... 550 V

12.21 Varistor test

U_{dc} – DC voltage

Measuring range (V)	Resolution (V)	Accuracy
0 ... 2500	1	±(3 % of reading + 3 digits)

U_{ac} – AC voltage

Measuring range (V)	Resolution (V)	Accuracy
0 ... 1562	1	Consider accuracy of DC voltage

Measurement principle d.c. voltage ramp
 Test voltage slope Nominal test voltage 1000 V: 100 V/s
 Nominal test voltage 2500 V: 350 V/s
 Threshold current 1 mA

12.22 Currents

Maximum voltage on C1 measuring input3 V

Nominal frequency.....0 Hz, 40 Hz ... 500 Hz

Ch1 clamp type: A1018

Range: 20 A

I1 – Current

Measuring range (A)	Resolution (A)	Accuracy*
0.0 m ... 99.9 m	0.1 m	$\pm(5\% \text{ of reading} + 5 \text{ digits})$
100 m ... 999 m	1 m	$\pm(3\% \text{ of reading} + 3 \text{ digits})$
1.00 ... 19.99	0.01	$\pm(3\% \text{ of reading})$

Ch1 clamp type: A1019

Range: 20 A

I1 – Current

Measuring range (A)	Resolution (A)	Accuracy*
0.0 m ... 99.9 m	0.1 m	indicative
100 m ... 999 m	1 m	$\pm(5\% \text{ of reading})$
1.00 ... 19.99	0.01	$\pm(3\% \text{ of reading})$

Ch1 clamp type: A1391

Range: 40 A

I1 – Current

Measuring range (A)	Resolution (A)	Accuracy*
0.00 ... 1.99	0.01	$\pm(3\% \text{ of reading} + 3 \text{ digits})$
2.00 ... 19.99	0.01	$\pm(3\% \text{ of reading})$
20.0 ... 39.9	0.1	$\pm(3\% \text{ of reading})$

Ch1 clamp type: A1391

Range: 300 A

I1 – Current

Measuring range (A)	Resolution (A)	Accuracy*
0.00 ... 19.99	0.01	indicative
20.0 ... 39.9	0.1	
40.0 ... 299.9	0.1	$\pm(3\% \text{ of reading} + 5 \text{ digits})$

* Accuracy at operating conditions for instrument and current clamp is given.

12.23 Current clamp meter (MI 3144)

This test is performed in combination with an external test adapter / instrument.

For technical specification refer to **MI 3144 Euro Z 800 V Instruction manual**.

12.24 Power

Measurement characteristics

Function symbols	Class according to IEC 61557-12	Measuring range
P – Active power	2.5	5 % ... 100 % $I_{Nom}^{*)}$
S – Apparent power	2.5	5 % ... 100 % $I_{Nom}^{*)}$
Q – Reactive power	2.5	5 % ... 100 % $I_{Nom}^{*)}$
PF – Power factor	1	- 1 ... 1
THDu	2.5	0 % ... 20 % U_{Nom}

^{*)} I_{Nom} depends on selected current clamp type and selected range as follows:

A 1018: [20 A]

A1019: [20 A]

A 1391: [40 A, 300 A]

Function	Measuring range
Power (P, S, Q)	0.00 W (VA, Var) ... 99.9 kW (kVA, kVar)
Power factor	-1.00 ... 1.00
Voltage THD	0.1 % ... 99.9 %

Error of external voltage and current transducers is not considered in this specification.

12.25 Harmonics

Measurement characteristics

Function symbols	Class according to IEC 61557-12	Measuring range
Uh	2.5	0 % ... 20 % U_{Nom}
THDu	2.5	0 % ... 20 % U_{Nom}
Ih	2.5	0 % ... 100 % $I_{Nom}^{*)}$
THDi	2.5	0 % ... 100 % $I_{Nom}^{*)}$

^{*)} I_{Nom} depends on selected current clamp type and selected range as follows:

A 1018: [20 A]

A1019: [20 A]

A 1391: [40 A, 300 A]

Function	Measuring range
Voltage harmonics	0.1 V ... 500 V
Voltage THD	0.1 % ... 99.9 %
Current harmonics and Current THD	0.00 A ... 199.9 A

Error of external voltage and current transducers is not considered in this specification.

12.26 ISFL – First fault leakage current

Isc1, Isc2 – First fault leakage current

Measuring range (mA)	Resolution (mA)	Accuracy
0.0 ... 19.9	0.1	$\pm(5\% \text{ of reading} + 3 \text{ digits})$

Measuring resistance..... approx. 390 Ω

Nominal voltage ranges 93 V $\leq U_{L1-L2} < 134$ V

185 V $\leq U_{L1-L2} \leq 266$ V

12.27 IMD

R1, R2 – Threshold insulation resistance

R (kΩ)	Resolution (kΩ)	Note
5 ... 640	5	up to 128 steps

I1, I2 – First fault leakage current at threshold insulation resistance

I (mA)	Resolution (mA)	Note
0.0 ... 19.9	0.1	calculated value ^{*)}

t1, t2 – Activation / disconnection time of IMD

t1, t2 (s)	Resolution (s)	Accuracy
0.00 ... 19.99	0.01	± 0.01 s
20.0 ... 99.9	0.1	± 0.1 s

Nominal voltage ranges $93 \text{ V} \leq U_{L1-L2} \leq 134 \text{ V}$
 $185 \text{ V} \leq U_{L1-L2} \leq 266 \text{ V}$

^{*)}See chapter **7.34 IMD – Testing of insulation monitoring devices** for more information about calculation of first fault leakage current at threshold insulation resistance.

12.28 Illumination

E – Illumination (A 1172)

Specified accuracy is valid for complete operating range.

Measuring range (lux)	Resolution (lux)	Accuracy
0.01 ... 19.99	0.01	±(5 % of reading + 2 digits)
20.0 ... 199.9	0.1	±(5 % of reading)
200 ... 1999	1	
2.00 k ... 19.99 k	10	

Measurement principlesilicon photodiode with $V(\lambda)$ filter
 Spectral response error< 3.8 % according to CIE curve
 Cosine error.....< 2.5 % up to an incident angle of $\pm 85^\circ$
 Overall accuracy.....matched to DIN 5032 class B standard

E – Illumination (A 1173)

Specified accuracy is valid for complete operating range.

Measuring range (lux)	Resolution (lux)	Accuracy
0.01 ... 19.99	0.01	±(10 % of reading + 3 digits)
20.0 ... 199.9	0.1	±(10 % of reading)
200 ... 1999	1	
2.00 k ... 19.99 k	10	

Measurement principlesilicon photodiode
 Cosine error.....< 2.5 % up to an incident angle of $\pm 85^\circ$
 Overall accuracy.....matched to DIN 5032 class C standard

12.29 Discharging time

t – Discharging time

Measuring range according to EN 61557-14 is 0.8 s ... 9.9 s.

Range (s)	Resolution (s)	Accuracy
0.0 s ... 9.9	0.1	±(5 % of reading + 2 digits)

Up – Peak voltage

Range (V)	Resolution (V)	Accuracy
0 ... 550	1	±(5 % of reading + 3 digits)

High limits..... 1 s, 5 s
 Threshold voltage..... 34 V, 60 V, 120 V
 Input resistance 20 MΩ

12.30 Auto Sequences®

Refer to each individual test (measurement) for detailed technical specification.

12.31 R line mΩ - DC resistance measurement (MI 3144)

This test is performed in combination with an external test adapter / instrument.
 For technical specification refer to *MI 3144 Euro Z 800 V Instruction manual*.

12.32 ELR Current injection (MI 3144)

This test is performed in combination with an external test adapter / instrument.
 For technical specification refer to *MI 3144 Euro Z 800 V Instruction manual*.

12.33 ELR Combination time test (MI 3144)

This test is performed in combination with an external test adapter / instrument.
 For technical specification refer to *MI 3144 Euro Z 800 V Instruction manual*.

12.34 EVSE Diagnostic test (A 1632)

This test is performed in combination with an external test adapter / instrument.
 For technical specification refer to *A 1632 eMobility Analyzer Instruction manual*.

12.35 Power CLAMP (MD 9273)

This test is performed in combination with an external test adapter / instrument.
 For technical specification refer to *MD 9273 Leakage Clamp meter with Bluetooth® Communication Instruction manual*.

12.36 Voltage CLAMP (MD 9273)

This test is performed in combination with an external test adapter / instrument.
For technical specification refer to **MD 9273 Leakage Clamp meter with Bluetooth® Communication Instruction manual.**

12.37 Current CLAMP (MD 9273)

This test is performed in combination with an external test adapter / instrument.
For technical specification refer to **MD 9273 Leakage Clamp meter with Bluetooth® Communication Instruction manual.**

12.38 Inrush CLAMP (MD 9273)

This test is performed in combination with an external test adapter / instrument.
For technical specification refer to **MD 9273 Leakage Clamp meter with Bluetooth® Communication Instruction manual.**

12.39 Harmonics U CLAMP (MD 9273)

This test is performed in combination with an external test adapter / instrument.
For technical specification refer to **MD 9273 Leakage Clamp meter with Bluetooth® Communication Instruction manual.**

12.40 Harmonics I CLAMP (MD 9273)

This test is performed in combination with an external test adapter / instrument.
For technical specification refer to **MD 9273 Leakage Clamp meter with Bluetooth® Communication Instruction manual.**

12.41 General data

Power supply	Li-Ion battery pack 7.2 V, 4400 mAh (type: 18650T22A2S2P) 8800 mAh (type: 18650T22A2S4P) optional
Operation.....	Typical 16 h (type: 18650T22A2S2P) Typical 32 h (type: 18650T22A2S4P)
Charger socket input voltage	12 V \pm 10 %
Charger socket input current.....	3000 mA max.
Battery charging current	up to 2200 mA (Battery type: 18650T22A2S2P) up to 3000 mA (Battery type: 18650T22A2S4P)
Measuring category	600 V CAT III 300 V CAT IV
Protection classification	double insulation
Pollution degree.....	2
Protection degree	56 (with protective covers on USB, Charger and PS/2 terminals)
Display	4.3 inch (10.9 cm) 480x272 pixels TFT colour display with touch screen
Dimensions (w \times h \times d)	252 mm \times 111 mm \times 165 mm
Weight	1.78 kg, with battery pack (type: 18650T22A2S2P)

Reference conditions

Reference temperature range.....	10 °C ... 30 °C
Reference humidity range.....	40 %RH ... 70 %RH

Operation conditions

Working temperature range	0 °C ... 40 °C
Maximum relative humidity	95 %RH (0 °C ... 40 °C), non-condensing

Storage conditions

Temperature range.....	-10 °C ... +70 °C
Maximum relative humidity	90 %RH (-10 °C ... +40 °C) 80 %RH (40 °C ... 60 °C)

Locator

Locator	supports inductive mode
Maximum operation voltage.....	440 V a.c.

Communication ports, memory

RS 232	115200 bits/s, 8N1 serial protocol
USB.....	USB 2.0 Hi speed interface with USB type B receptacle connector
Data storage capacity	8 GB SD memory card
Bluetooth module.....	Class 2

The error in operating conditions could be at most the error for reference conditions (specified in the manual for each function) +1 % of measured value + 1 digit, unless otherwise specified in the manual for particular function.

Appendix A Commanders (A 1314, A 1401)

A.1 ⚠ Warnings related to safety

Measuring category of commanders

Plug commander A 1314-UK.....300 V CAT II

Tip commander A 1401

(cap off, 18 mm tip)1000 V CAT II / 600 V CAT II / 300 V CAT II

(cap on, 4 mm tip)1000 V CAT II / 600 V CAT III / 300 V CAT IV

- Measuring category of commanders can be lower than protection category of the instrument.
- If dangerous voltage is detected on the tested PE terminal, immediately stop all measurements, find and remove the fault!
- When replacing battery cells or before opening the battery compartment cover, disconnect the measuring accessory from the instrument and installation.
- Service, repairs or adjustment of instruments and accessories is only allowed to be carried out by competent authorized personnel!

A.2 Battery

The commander uses two AAA size alkaline or rechargeable Ni-MH battery cells. Nominal operating time is at least 40 h and is declared for cells with nominal capacity of 850 mAh.

Notes:

- If the commander is not used for a long period of time, remove all batteries from the battery compartment.
- Alkaline or rechargeable Ni-MH batteries (size AAA) can be used. Metrel recommends only using rechargeable batteries with a capacity of 800 mAh or above.
- Ensure that the battery cells are inserted correctly otherwise the commander will not operate and the batteries could be discharged.

A.3 Description of commanders

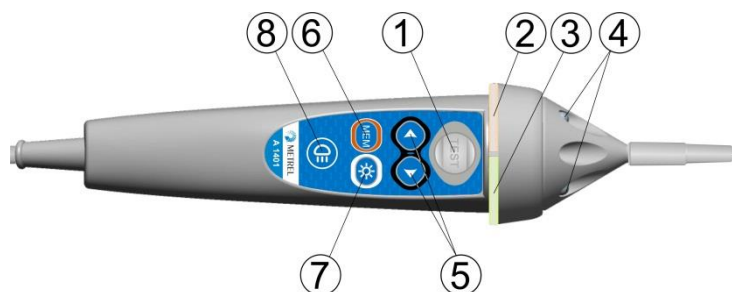

Figure A.1: Front side Tip commander (A 1401)

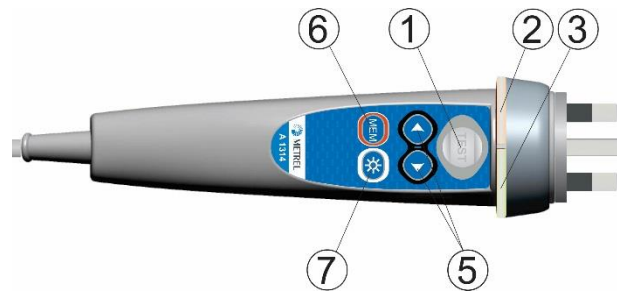

Figure A.2: Front side Plug commander (A 1314-UK)

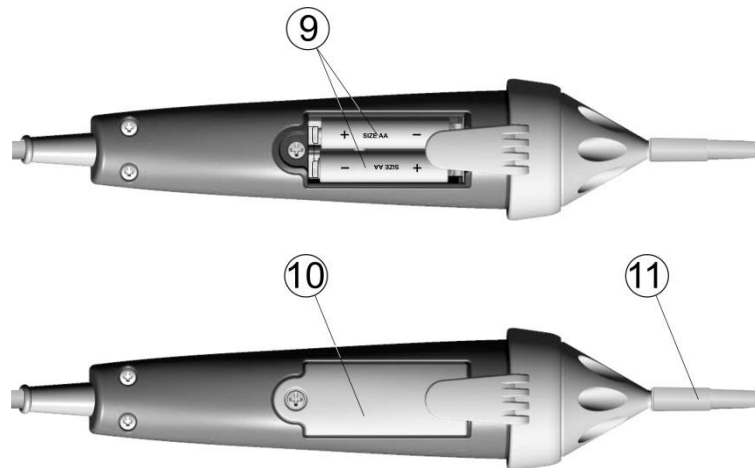

Figure A.3: Back side

1	TEST	TEST	Starts measurements. Acts also as the PE touching electrode.
2	LED	Left status	RGB LED
3	LED	Right status	RGB LED
4	LEDs	Lamp LEDs	(Tip commander)
5	Function selector	Selects test function.	
6	MEM	Store / recall / clear tests in memory of instrument.	
7	BL	Switches On / Off backlight on instrument	
8	Lamp key	Switches On / Off lamp (Tip commander)	
9	Battery cells	Size AAA, alkaline / rechargeable Ni-MH	
10	Battery cover	Battery compartment cover	
11	Cap	Removable CAT IV cap (Tip commander)	

A.4 Operation of commanders

Both LED yellow	Warning! Dangerous voltage on the commander's PE terminal!
Right LED red	Fail indication
Right LED green	Pass indication
Left LED blinks blue	Commander is monitoring the input voltage.
Left LED orange	Voltage between any test terminals is higher than 50 V.
Both LEDs blink red	Low battery
Both LEDs red and switch off	Battery voltage too low for operation of commander

Appendix B Locator receiver R10K

The highly sensitive hand-held **receiver R10K** detects the fields caused by the currents in the traced line. It generates sound and visual output according to the signal intensity. The operating mode switch in the head detector should always be set in IND (inductive) mode. The CAP (capacitive) operating mode is intended for operating in combination with other Metrel measuring equipment.

The built-in field detector is placed in the front end of the receiver. External detectors can be connected via the rear connector.

Traced object must be energized when working with the EurotestXD.

Detectors	Operation
In built inductive sensor (IND)	Tracing hidden wires.
Current clamp (optional)	Connected through the rear connector. Locating wires.
Selective probe	Connected through the rear connector. Locating fuses in fuse cabinets.



Figure B.1: Receiver R10K

The user can choose between three sensitivity levels (low, middle and high). An extra potentiometer is added for fine sensitivity adjustment. A buzzer sound and 10-level LED bar graph indicator indicates the strength of the magnetic field e.g. proximity of the traced object.

Note:







- The field strength can vary during tracing. The sensitivity should always be adjusted to optimum for each individual tracing.

Appendix C Structure objects

Structure elements used in Memory Organizer are instrument's Profile dependent.

Symbol	Default name	Description
	Node	Node
	Object	Object
	Dist. board	Distribution board
	Sub D. Board	Sub Distribution board
	Local bonding	Local equipotential bonding
	Water Service	Protective conductor for Water service
	Oil service	Protective conductor for Oil service
	Lightn. protect.	Protective conductor for Lightning protection
	Gas service	Protective conductor for Gas service
	Struct. steel	Protective conductor for Structural steel
	Other service	Protective conductor for Other incoming service
	Earthing cond.	Earthing conductor
	Circuit	Circuit
	Connection	Connection
	Socket	Socket
	Connection 3-ph	Connection - 3 phase
	Light	Light
	Socket 3-ph	Socket - 3 phase
	RCD	RCD
	MPE	MPE

Symbol	Default name	Description
	Foundation gr.	Protective conductor for Foundation ground
	Equip. bond. rail	Equipotential bonding rail
	House water m.	Protection conductor for House water meter
	Main water p.	Protection conductor for Main water pipes
	Main gr. cond.	Main grounding conductor
	Inter. gas inst.	Protective conductor for Interior gas installation
	Heat.inst.	Protective conductor for Heating installation
	Air cond. inst.	Protective conductor for Air conditioning installation
	Lift inst.	Protective conductor for Lift installation
	Data proc. Inst.	Protective conductor for Lift Data processing installation
	Teleph. Inst.	Protective conductor for Telephone installation
	Lightn. prot. syst.	Protective conductor for Lightning protection system
	Antenna inst.	Protective conductor for Antenna installation
	Build. Constr.	Protective conductor for Building construction
	Other conn.	Other connection
	Earth electrode	Earth electrode
	Lightning Sys.	Lightning System
	Lightning. electr.	Lightning electrode
	Inverter	Inverter
	String	String array
	Panel	Panel
	EVSE	Electro-Vehicle supply Equipment

Symbol	Default name	Description
	Level 1	Level 1
	Level 2	Level 2
	Level 3	Level 3
	Varistor	Varistor
	LS connection	LS connection
	Machine	Machine
	Appliance	Appliance (PRCD)

Appendix D Default list of Auto Sequences®

Default list of Auto Sequences® for MI 3155 – Eurotest XD instrument is available on Metrel home page www.metrel.si.

Appendix E Programming of Auto Sequences® on Metrel ES Manager

The Auto Sequence® editor is a part of the Metrel ES Manager software. In Auto Sequence® editor Auto Sequence® can be pre-programmed and organized in groups, before uploaded to the instrument.

E.1 Auto Sequence® Editor workspace

To enter Auto Sequence® editor's workspace, select **Auto Sequence® Editor** in Home Tab of Metrel ES Manager PC SW. Auto Sequence® editor workspace is divided in four main areas.

On the left side **1**, structure of selected group of Auto Sequence® is displayed. In the middle part of the workspace **2**, the elements of the selected Auto Sequence® are shown.

On the right side, list of available Single tests (measurements and inspections) **3** and list of Flow commands **4** are shown.

Single test area contain three tabs, Measurements, Inspections and Custom Inspections tab. Custom Inspections and their tasks are programmed by user, see chapter **E.8 Custom Inspections programming** for procedure.

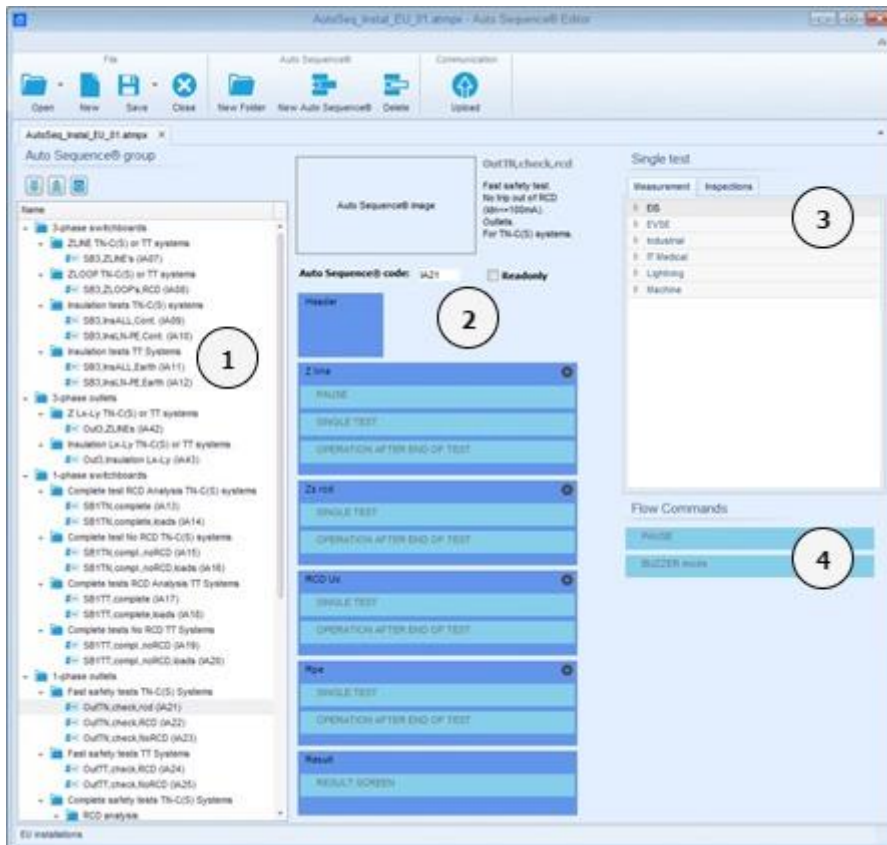

Figure E.1: Auto Sequence® Editor workspace

An Auto Sequence® ² begins with Name, Description and Image, followed by the first step (Header), one or more measuring steps and ends with the last step (Result). By inserting appropriate Single tests (measurements and inspections) ³ and Flow commands ⁴ and setting their parameters, arbitrary Auto Sequences® can be created.

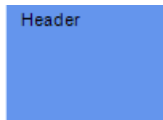

Figure E.2: Example of an empty Auto Sequence® header

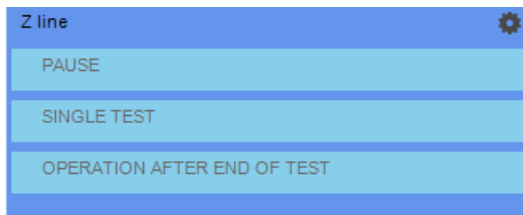

Figure E.3: Example of a measurement step



Figure E.4: Example of an Auto Sequence® result

E.2 Managing groups of Auto Sequences®

The Auto Sequences® can be divided into different user defined groups of Auto Sequences®. Each group of Auto Sequences® is stored in a file. More files can be opened simultaneously in Auto Sequence® editor.

Within Auto Sequences® Group, tree structure can be organized, with folders / subfolders containing Auto Sequences®. The tree structure of currently active Group of Auto Sequences® is displayed on the left side of the Auto Sequence® Editor workspace, see **Figure E.5**.

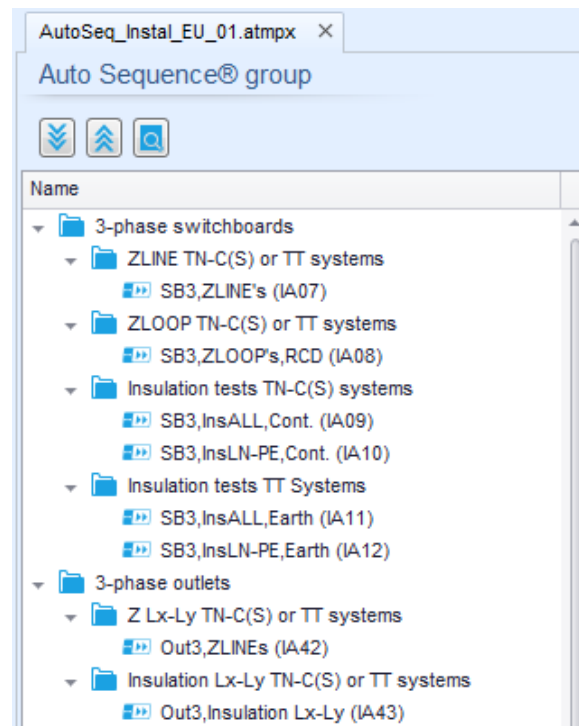

Figure E.5: Group of Auto Sequences® tree organization

Operation options on Group of Auto Sequences® are available from menu bar at the top of Auto Sequence® Editor workspace.

File operation options:



Opens a file (Group of Auto Sequences®).



Creates a new file (Group of Auto Sequences®).



Saves / Saves as the opened Group of Auto sequences® to a file.



Closes the file (Group of Auto Sequences®).

Group of Auto Sequences® view options:



Expand all folders / subfolders / Auto Sequences®.



Collapse all folders / subfolders / Auto Sequences®.



Toggle between Search by name within Auto Sequence® group and normal view. See chapter **E.4 Search within selected Auto Sequence® group** for details.

Group of Auto Sequences® operation options (also available by right clicking on Folder or Auto Sequence®):



Adds a new folder / subfolder to the group



Adds a new Auto Sequence® to the group.



Deletes:

- the selected Auto Sequence®
- the selected folder with all subfolders and Auto Sequences®

Right click on the selected Auto Sequence® or Folder opens menu with additional possibilities:



Auto Sequence®: Edit Name, Description and Image (see **Figure E.6**).

Folder: Edit folder name



Auto Sequence®: Copy to clipboard

Folder: Copy to clipboard including subfolders and Auto Sequences®



Auto Sequence®: Paste it to selected location

Folder: Paste it to selected location



Auto Sequence®: Creates shortcut to selected Auto Sequence®

Double click on the object name allows it name edit:

DOUBLE CLICK	<p>Auto Sequence® name: Edit Auto Sequence® name</p> <div style="border: 1px solid #ccc; padding: 2px; margin-bottom: 5px;"> OutTT,NoRCD (IA40) </div> <p>Folder name: Edit folder name</p> <div style="border: 1px solid #ccc; padding: 2px; margin-bottom: 5px;"> Complete safety tests TT Systems </div>
--------------	---

Drag and drop of the selected Auto Sequence® or Folder / Subfolder moves it to a new location:

DRAG & DROP	<p>'Drag and drop' functionality is equivalent to 'cut' and 'paste' in a single move.</p> <p> move to folder</p> <p> insert</p>
-------------	---

E.3 Auto Sequence® Name, Description and Image editing

When EDIT function is selected on Auto Sequence®, menu for editing presented on **Figure E.6** appear on the screen. Editing options are:

Name: Edit or change the name of Auto Sequence®.

Description: Any text for additional description of Auto Sequence® can be entered.

Image: Image presenting Auto sequence® measuring arrangement can be entered or deleted.



Enters menu for browsing to Image location.



Deletes the Image from Auto Sequence®.

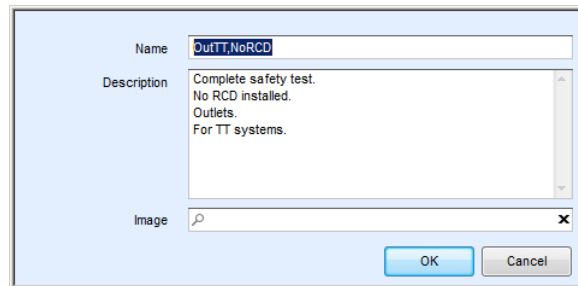



Figure E.6: Editing the Auto Sequence® Name, Description and Image

E.4 Search within selected Auto Sequence® group

When  function is selected, Search menu as presented on **Figure E.7** appear on the screen. By entering the text into search box, found results are automatically highlighted with yellow background. Search functionality is implemented in Folders, Subfolders and Auto Sequences® of selected Auto Sequence® Group. Search text can be cleared by selecting the Clear button.

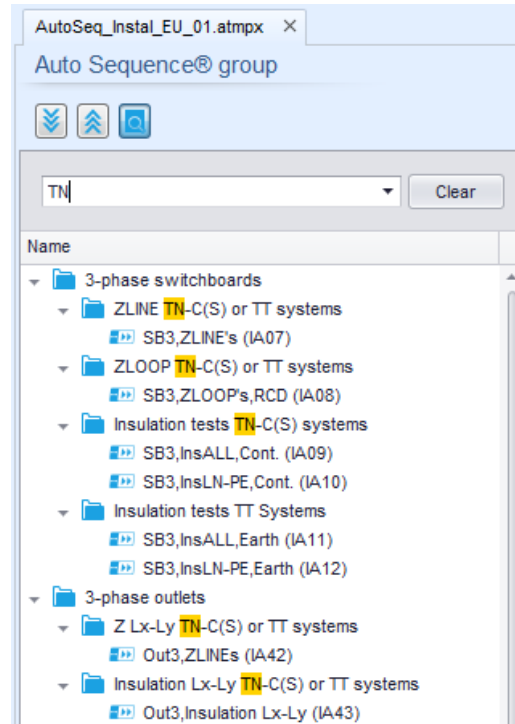

Figure E.7: Example of Search result within Auto Sequence® group

E.5 Elements of an Auto Sequence®

E.5.1 Auto Sequence® steps

There are three kinds of Auto Sequence® steps.

Header

The Header step is empty by default.

Flow commands can be added to the Header step.

Measurement step

The Measurement step contains a Single test and the Operation after end of test flow command by default. Other Flow commands can also be added to the Measurement step.

Result

The Result step contains the Result screen flow command by default. Other Flow commands can also be added to the Result step.

E.5.2 Single tests

Single tests are the same as in Metrel ES Manager Measurement menu.

Limits and parameters of the measurements can be set. Results and sub-results can't be set.

E.5.3 Flow commands

Flow commands are used to control the flow of measurements. Refer to chapter **E.7 Description of flow commands** for more information.





E.5.4 Number of measurement steps

Often the same measurement step has to be performed on multiple points on the device under test. It is possible to set how many times a Measurement step will be repeated. All carried out individual Single test results are stored in the Auto Sequence® result as if they were programmed as independent measuring steps.

E.6 Creating / modifying an Auto Sequence®

If creating a new Auto Sequence® from scratch, the first step (Header) and the last step (Result) are offered by default. Measurement steps are inserted by the user.

Options

Adding a measurement step	By double clicking on a Single test a new measurement step will appear as the last of measurement steps. It can also be dragged and dropped on the appropriate position in the Auto Sequence®.
Adding flow commands	Selected flow command can be dragged from the list of Flow Commands and dropped on the appropriate place in any Auto Sequence® step.
Changing position of flow command within measurement step	By a click on an element and use of  and  keys.
Viewing / changing parameters of flow commands or single tests.	By a double click on the element.
Setting number of measurement step repetitions.	By setting a number in the  field.
Touch pre-test disable / enable (not available in all functions)	By setting True / False in the  field. (Default value is False – Touch pre-test is enabled)

Right click on the selected measurement step / flow command:

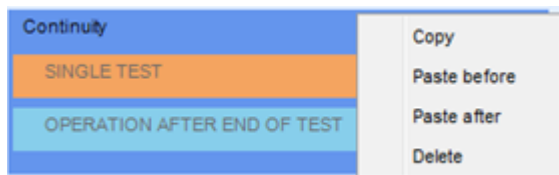

Copy – Paste before

A measurement step / flow command can be copied and pasted above selected location on the same or on another Auto Sequence®.

Copy – Paste after

A measurement step / flow command can be copied and pasted under selected location on the same or on another Auto Sequence®.

Delete

Deletes the selected measurement step / flow command.

E.7 Description of flow commands

Double click on inserted Flow Command opens menu window, where text or picture can be entered, external commands can be activated and parameters can be set.

Flow commands Operation after end of test and Results screen are entered by default, others are user selectable from Flow Commands menu.

Pause

A Pause command with text message or picture can be inserted anywhere in the measuring steps. Warning icon can be set alone or added to text message. Arbitrary text message can be entered in prepared field Text of menu window.

Parameters

Pause type Show text and/or warning (check to show warning icon).
 Show picture ( browse for image path).

Duration Number in seconds, infinite (no entry).

Buzzer mode

Passed or failed measurement is indicated with beeps.

- Pass – double beep after the test
- Fail – long beep after the test

Beep happens right after single test measurement.

Parameters

State On – enables Buzzer mode
 Off – disables Buzzer mode

Operation after end of test

This flow command controls the proceeding of the Auto Sequence® in regard to the measurement results.

Parameters

Operation after end of test	The operation can be individually set for the case the measurement passed, failed or ended without a status.
<ul style="list-style-type: none"> · pass · fail · no status 	<p>Manual: The test sequence stops and waits for appropriate command (RUN key, external command ...) to proceed.</p> <p>Auto: The test sequence automatically proceeds.</p>

Result screen

This flow command controls the proceeding after the Auto Sequence® has ended.

Parameters

- Auto save Auto Sequence® results are stored in the momentary workspace.
- A new Node with the current month and year will be created. Under the Node Auto Sequence® results will be stored.
- Up to 100 Auto Sequence® results can be automatically stored under the same node. If more results are available, they are split to multiple nodes.
- Auto Save Flow setting is disabled by default.

Note

- This flow command is active only if Auto Sequence® is started from the Auto Sequence® Main menu (not from the Memory organizer).

E.8 Custom Inspections programming

Arbitrary set of tasks dedicated to specific user defined Inspections can be programmed with application of Custom Inspection Editor Tool, accessible from Auto Sequence® Editor workspace. Custom Inspections are stored in dedicated file *.indf with user defined name. For application of Custom Inspections as a single test within Auto Sequence® group, appropriate file containing specific Custom Inspection should be opened first.

E.8.1 Creating and editing Custom Inspections

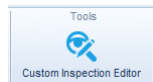
Custom Inspection Editor workspace is entered by selecting  icon from Auto Sequences® main menu. It is divided in two main areas, as presented on **Figure E.8:**

- 1 Custom Inspection **Name** and **Scope** of inspection (Visual or Functional)
- 2 **Name** of Custom Inspection Item tasks and **Type** of Item Pass / Fail checkbox marking

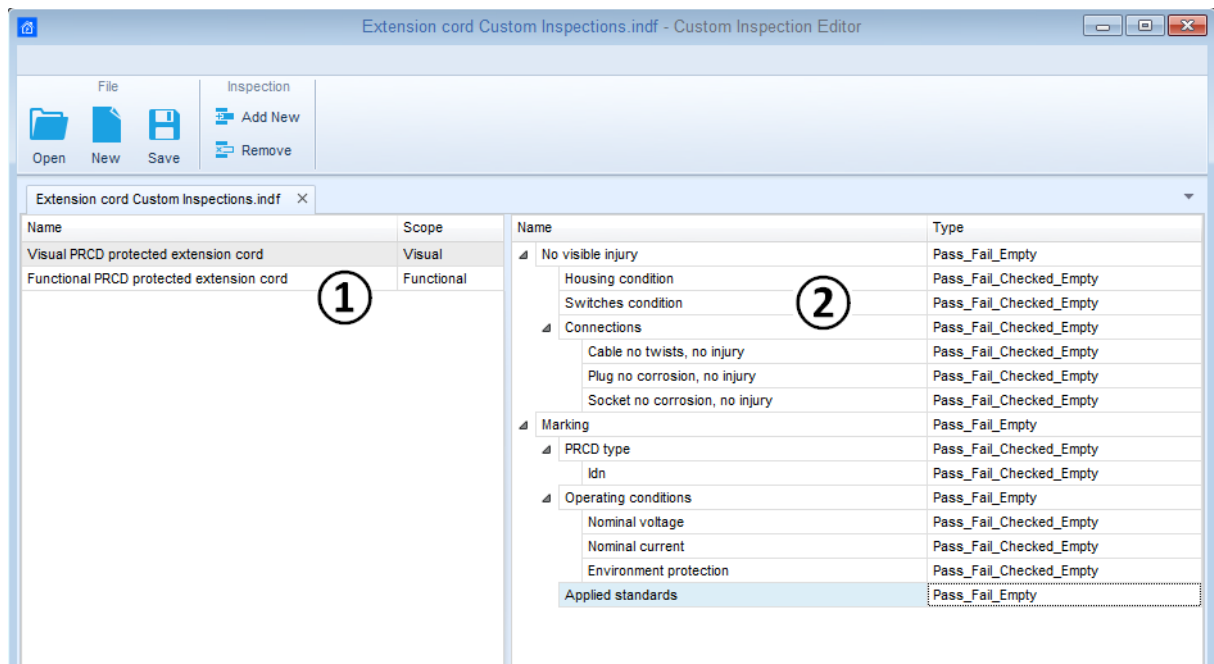

Figure E.8: Custom Inspection Editor workspace

Custom Inspection Editor Main menu options:



Opens existing Custom Inspection Data file.
By selecting, menu for browsing to location of *.indf file containing one or more Custom Inspections data appear on the screen. Selected file is opened in dedicated tab marked with file name.



Creates a new Custom Inspection Data file.
New tab with empty workspace is opened. Default name of the new tab is *Inspection Data File*; it could be renamed during Save procedure.



Saves / Saves as Custom Inspection Data file opened on active tab.
Menu for browsing to the folder location and editing of file name is opened. Browse to the location, confirm overwriting, if file already exists or edit file name to save it as a new Custom Inspection Data file.



Add New Custom Inspection.
New inspection with default name *Custom Inspection* and default scope *Visual* appear on the editor workspace. It contains one Item task with default name *Custom Inspection* and default Type *Pass_Fail_Checked_Empty*. Default Name and Type can be edited – changed.



Remove selected custom inspection.
To select inspection, click to the inspection Name field. To remove it, select icon from editor main menu. Before removal, user is asked to confirm deletion.

Edit Name and Scope of Inspection

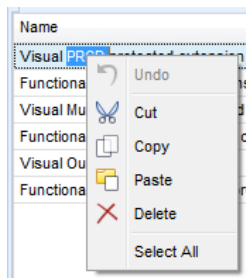

Inspection Name edit:

Click to the Inspection Name field to start editing it.

Drag cursor, with left mouse button pressed, to select letters and words. Position cursor and double-click to select word of the name.

Actions could be performed with keyboard also.

Press right mouse button to activate Edit menu and select appropriate action as presented on the left figure. Menu is case sensitive; options currently not available are greyed out.

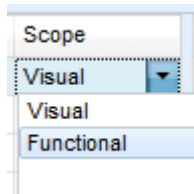

Inspection Scope edit:

Click to Inspection Scope field to open selection menu presented on left figure. Options:

Visual is intended for observation of test object

Functional allows functional test of observed object

Edit Item task structure of Inspection

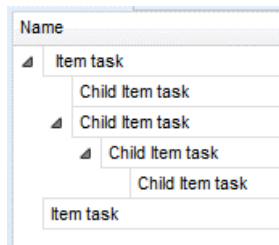

Item tasks of the selected Inspection are listed in Name column on the right side of Editor workspace.

Each Item task can have Child Item tasks, Child Item can have its own Child Item tasks and so on.

Arbitrary tree structure of Item tasks and subtasks can be built as presented on left figure

ADD New Item task procedure:

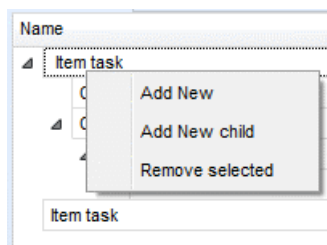

Position cursor above Item task Name and apply right mouse click to select Item task and open menu with options:

Add New: new Item task is added on the top tree level

Add New Child: new child Item task is added under selected Item

Remove selected: delete selected Item task with all subtasks

Default Name of New Item task is *Custom Inspection*, default Type *Pass_Fail_Checked_Empty* and both can be edited – changed.

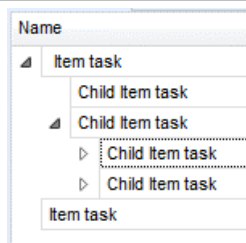

Item tasks containing Child Item tasks are marked with triangle in front of their Name.

Click on triangle mark:

- ▲ collapse Item task tree structure
- ▶ expands Item task tree structure

Edit Name and Type of Item task

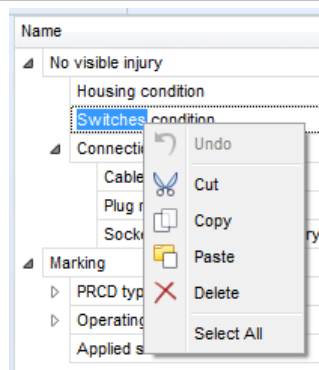

Edit Name of Item task:

Click to the Item task Name field to start editing it. Drag cursor, with left mouse button pressed, to select letters and words. Position cursor and double-click to select word of the name. Actions could be performed with keyboard also. Press right mouse button to activate Edit menu and select appropriate action as presented on the left figure. Menu is case sensitive; options currently not available are greyed out.

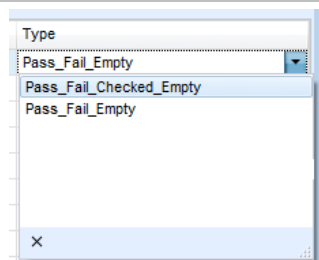

Edit Type of Item task:

Click to Item Type field to open selection menu presented on left figure. Selectable checkbox status assignment options are:

Pass_Fail_Checked_Empty: Pass, Fail, Checked, Empty (default)

Pass_Fail_Empty: Pass, Fail selection, Empty (default) value

E.8.2 Applying Custom Inspections

Custom inspections can be applied in Auto Sequences®. Direct assignment of Custom inspection to the Metrel ES manager structure objects is not possible.

After custom created Inspection Data file is opened, available inspections are listed in Custom Inspections tab of Single test area of Auto Sequence® Editor, see chapter **E.1 Auto Sequence® Editor workspace** for details.

Custom Inspection is added to Auto sequence as a Single test, see chapter **E.6 Creating / modifying an Auto Sequence®** for details.

Opening / changing Inspection Data File

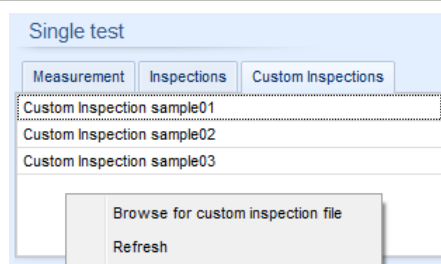

Position cursor within Custom inspections List area and apply mouse right click to open Option menu:

Refresh: Refresh content of already opened Inspection Data file

Browse for custom Inspection file:

Menu for browsing to folder location of new Inspection Data file is opened.

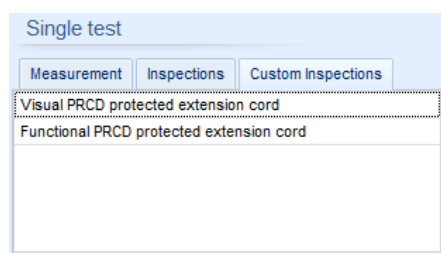













After confirmation of selection, new Inspection Data file is opened and list of available Custom Inspections is changed.

Note:

- If Metrel ES Manager Work scope is changed, opened Inspection Data file remains active and available Custom Inspections remains the same.

Appendix F Tests and Measurements with adapters

		 A 1507 3-phase active switch	 A 1143 Euro Z 290 A	 MI 3143 Euro Z 440 V	 MI 3144 Euro Z 800 V	 A 1632 eMobility Analyser	 MD 9273 Leakage Clamp meter with Bluetooth
Voltage	1-phase (TN/TT)	•	-	-	-	-	-
	1-phase (IT)	-	-	-	-	-	-
	3-phase	•	-	-	-	-	-
Socket test basic(live)		-	-	-	-	-	-
Riso	50 V – 1000 V	•	-	-	-	-	-
	2500 V	-	-	-	-	-	-
Riso all		-	-	-	-	-	-
Diagnostic test	50 V – 1000 V	-	-	-	-	-	-
	2500 V	-	-	-	-	-	-
Varistor		-	-	-	-	-	-
R low		•	-	-	-	-	-
Rlow 4W		-	-	-	-	-	-
Continuity		-	-	-	-	-	-
Ring Continuity		-	-	-	-	-	-
Socket		-	-	-	-	-	-
Rpe		•	-	-	-	-	-
RCD Auto		•	-	-	-	-	-
RCD Uc		•	-	-	-	-	-
RCD t		•	-	-	-	-	-
RCD I		•	-	-	-	-	-
Zs rcd		•	-	-	-	-	-
Z loop		•	-	-	-	-	-
Z loop 4W		-	-	-	-	-	-
Z loop mOhm		-	•	•	•	-	-
Z line mOhm		-	•	•	•	-	-
High Current		-	-	•	•	-	-
Current clamp Meter		-	-	-	•	-	-
Rline mOhm		-	-	-	•	-	-
ELR Current Injection Test		-	-	-	•	-	-
ELR Combination Time Test		-	-	-	•	-	-

	 A 1507 3-phase active switch	 A 1143 Euro Z 290 A	 MI 3143 Euro Z 440 V	 MI 3144 Euro Z 800 V	 A 1632 eMobility Analyser	 MD 9273 Leakage Clamp meter with Bluetooth
Utouch	-	-	•	•	-	-
Z auto	•	-	-	-	-	-
Z line	•	-	-	-	-	-
Z line 4W	-	-	-	-	-	-
Voltage Drop	•	-	-	-	-	-
Earth 3W	-	-	-	-	-	-
Earth 2 clamps	-	-	-	-	-	-
Ro	-	-	-	-	-	-
Power	-	-	-	-	-	-
Harmonics	-	-	-	-	-	-
Currents	-	-	-	-	-	-
IMD	-	-	-	-	-	-
ISFL	-	-	-	-	-	-
Locator	-	-	-	-	-	-
Discharging Time	-	-	-	-	-	-
Illumination	-	-	-	-	-	-
Diagnostic Test (EVSE)	-	-	-	-	•	-
Power CLAMP	-	-	-	-	-	•
Voltage CLAMP	-	-	-	-	-	•
Current CLAMP	-	-	-	-	-	•
Inrush CLAMP	-	-	-	-	-	•
Harmonics U CLAMP	-	-	-	-	-	•
Harmonics I CLAMP	-	-	-	-	-	•