



### Main

Range of product	OsiSense XG
Product or component type	Panel mounting smart antenna
RFID compact station name	XGCS
RFID frequency	13.56 MHz
Design	Diameter 22 mounting
Electrical connection	5 pin(s) 1 male connector M12
Transmission rate	9600 bauds...115200 bauds (automatic detection)
Outer dimension	40 x 40 x 40 mm
Product compatibility	RFID microchip INSIDE (micropass) RFID microchip STM (CRIX4K) RFID microchip Texas (Tag-it HFI) RFID microchip Fujitsu (MB89R118 - MB89R119) RFID microchip NXP (SL2, SL1, Ultralight, Std 1K/4K, Desfire) RFID microchip Microelectronic (EM4135)
[Sn] nominal sensing distance	10...70 mm
[Us] rated supply voltage	24 V DC conforming to Protective Extra Low Voltage

### Complementary

Communication port protocol	Modbus RTU
Communication port support	RS485 non isolated
Associated tag type	Automatic detection of the type of tag ISO 14443 standard tags ISO 15693 standard tags
Supply voltage limits	19.2...29 V DC
Current consumption	< 60 mA
Status LED	1 LED (dual colour) for communication network 1 LED (dual colour) for RFID communication
Tightening torque	< 2.2 N.m
Marking	CE
Product weight	0.057 kg

### Environment

Product certifications	UL, FCC
Standards	ETSI EN 301 489-1 ETSI EN 301 489-3 ETSI EN 300 330-1 ETSI EN 300 330-2
Ambient air temperature for operation	-25...70 °C
Ambient air temperature for storage	-40...85 °C
IP degree of protection	IP65 conforming to IEC 60529
Vibration resistance	2 mm (f = 5...29.5 Hz) conforming to EN 60068-2-6 7 gn (f = 29.5...150 Hz) conforming to EN 60068-2-6
Shock resistance	30 gn for 11 ms conforming to EN 60068-2-27

The information provided in this documentation contains general descriptions and/or technical characteristics of the performance of the products contained herein. This documentation is not intended as a substitute for and is not to be used for determining suitability or reliability of these products for specific user applications. It is the duty of any such user or integrator to perform the appropriate and complete risk analysis, evaluation and testing of the products with respect to the relevant specific application or use thereof. Neither Schneider Electric Industries SAS nor any of its affiliates or subsidiaries shall be responsible or liable for misuse of the information contained herein.

IK degree of protection	IK02 conforming to EN 50102
Electromagnetic compatibility	<p>Electrostatic discharge immunity test for contact discharge ( level: 3) - test level 6 kV conforming to IEC 61000-4-2</p> <p>Electrostatic discharge immunity test for air discharge ( level: 3) - test level 8 kV conforming to IEC 61000-4-2</p> <p>Susceptibility to electromagnetic fields ( level: 3) - test level 10 V/m conforming to IEC 61000-4-3</p> <p>Electrical fast transient/burst immunity test for signal ports ( level: 3) - test level 1 kV conforming to IEC 61000-4-4</p> <p>Electrical fast transient/burst immunity test for power ports ( level: 3) - test level 2 kV conforming to IEC 61000-4-4</p> <p>1.2/50 <math>\mu</math>s shock waves immunity test ( level: 3) - test level 10 kV conforming to IEC 61000-4-5</p> <p>Conducted RF disturbances ( level: 3) - test level 10 V conforming to IEC 61000-4-6</p> <p>Magnetic field at power frequency ( level: 4) - test level 30 A/m conforming to IEC 61000-4-8</p>

Dimensions

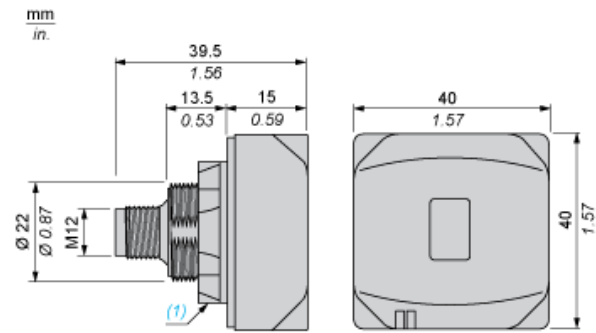

(1) Locking nut

Connections

Modbus Connections

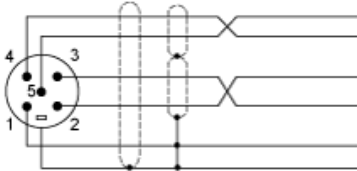

Pin no.	Modbus smart antenna signal
1	Drain (Modbus-SHLD)
2	+ 24 VDC
3	0 V/Modbus-GND
4	D0
5	D1

Connection Examples

Connection to a Terminal

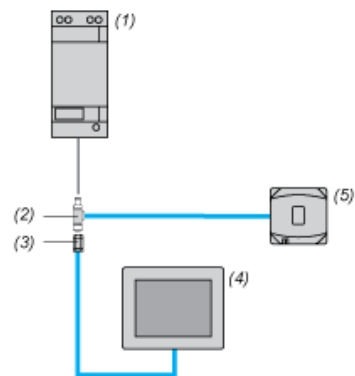

- (1) Power supply
- (2) Network Tee
- (3) Male M12 connector
- (4) Terminal
- (5) Smart antenna

## Connection to an Automation Platform

Daisy chain topology

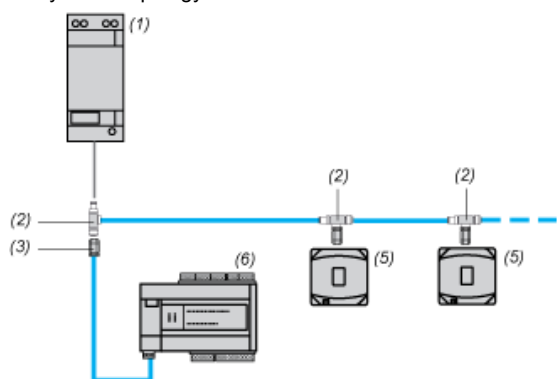

- (1) Power supply
- (2) Network Tee
- (3) Male M12 connector
- (4) Terminal
- (5) Smart antenna
- (6) Automation platform

Mounting and Clearance

Minimum Distance Between 2 Identical Smart Antennas According to their Positioning and Type of Tag Used

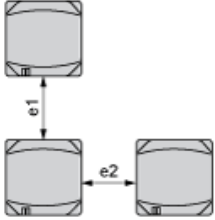

Dimensions in mm

Tag	e1	e2
XGHBPB3345	90	90
XGHB90E340	310	310
XGHB90E341	90	90

Dimensions in in.

Tag	e1	e2
XGHBPB3345	3.54	3.54
XGHB90E340	12.20	12.20
XGHB90E341	3.54	3.54