

Normal Slide Type

Application

- ✓ Audio, Home appliance, Lighting control, etc.

Feature

- ✓ Smooth slide feeling

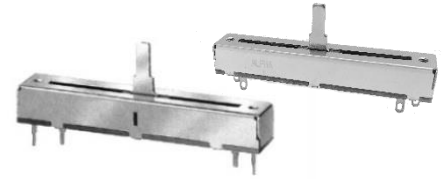

■Specification

Travel Distance	45mm , 60mm
Insulation Resistance	100 MΩ Min. at 500V DC
Dielectric Strength	500V AC , 1 minute
Operating Temperature Range	-10 °C~70°C
Operating Force	50~350 gf.cm
Sliding Life	15,000 cycles

■How to order

RA6020F-20 – 15C2- B10K

[Model](#)

[Lever Type](#)

Taper and Resistance Value

Ex:

Order Code	Taper	Resistance Value
A100K	Log/A	100KΩ
B1M	Linear/B	1MΩ

Taper: A and B



Resistance Value: 1KΩ to 500KΩ and 1MΩ

*Contact us for other requirements.

Normal Slide Type

Model Description

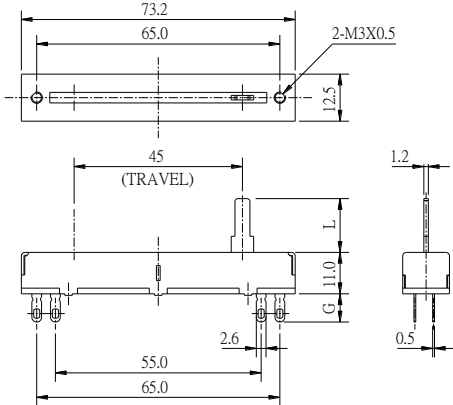

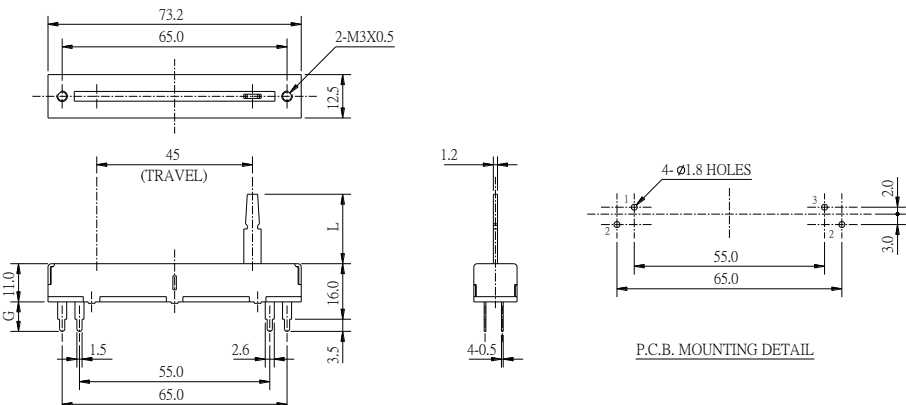
Model	Number of unit	Travel Distance	Type of Terminal
RA4520F-10	Single Unit	45mm	Solder Lug
RA4520F-20	Single Unit	45mm	PC Board
RA4520F-21	Single Unit	45mm	PC Board
RA6020F-10	Single Unit	60mm	Solder Lug
RA6020F-20	Single Unit	60mm	PC Board
RA6020F-21	Single Unit	60mm	PC Board

Order Code	Outline Drawing
RA4520F-10 	
RA4520F-20 RA4520F-21 	

For dimension of G, please refer to the below chart "[Type of Terminal](#)".

[Back to top](#)

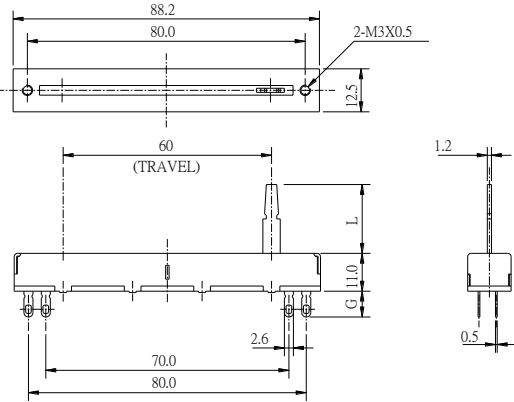
Normal Slide Type

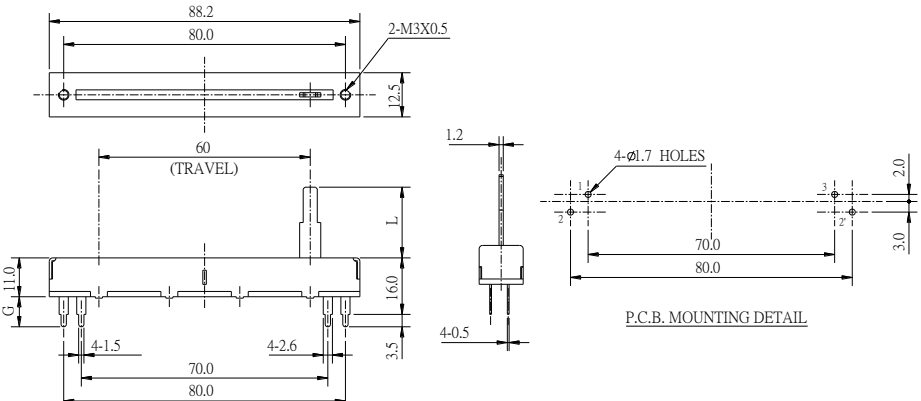
Order Code	Outline Drawing
RA6020F-10 	
RA6020F-20 RA6020F-21 	

For dimension of G, please refer to the below chart "[Type of Terminal](#)".

■Type of Terminal

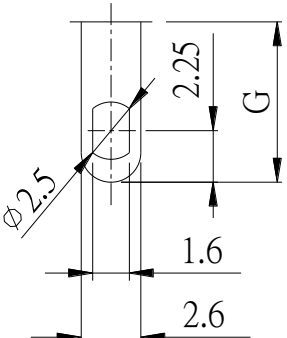
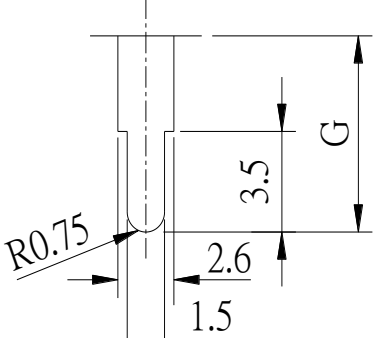
Type	Solder Lug Type		PC Board Type	
	10	20	20	21
Length (G)	7.5	8.5	8.5	7
Dimensions				

[Back to top](#)

Normal Slide Type

■ Lever Type

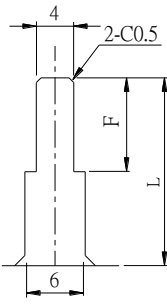
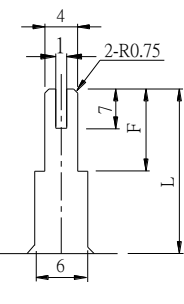
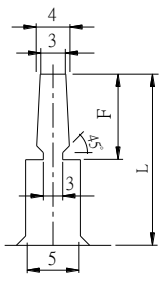
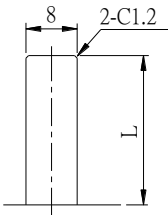
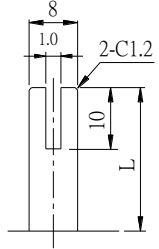
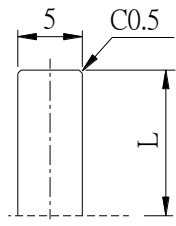
Model	RA□□20F Series									
Lever type	Metal Lever t1.2									
	C2		F2		D1		B1	E1		B2
Dimensions										
Length (L)	F	10	7	10	10	10	10	15	20	10
	L	15	10	15	15	20				

Design and specifications presented here are for the standard parts only. Please kindly contact us for your special requests and ask for the current technical specifications before purchase and/or use.

[Back to top](#)