

PICAXE

Order code	Manufacturer code	Description
70-1206	n/a	8-PIN PROJECT BOARD KIT (5)

PICAXE	Page 1 of 5
The enclosed information is believed to be correct, Information may change 'without notice' due to product improvement. Users should ensure that the product is suitable for their use. E. & O. E.	Revision A 04/07/2003

8 PIN PROJECT BOARD

Order Code:

CHI040 8 pin Project Board Self-Assembly Kit

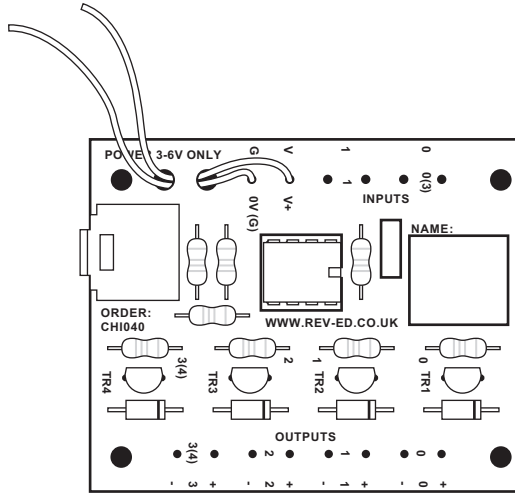

Features

The 8 pin project board provides a self assembly interface for the 8 pin PIC12F629 microcontroller. The project board provides 4 transistor buffered outputs for connection of output devices such as motors. The project board also provides input connections for inputs such as switches.

The project board can be used with traditional programming systems such as the Chip Factory, or by adding the extra 3.5mm stereo download socket, the direct cable download PICAXE-08 system can be used.

Parts list:

R1-2	2	10k carbon film 0.25W resistor	<i>brown black orange gold</i>
R3	1	22k carbon film 0.25W resistor	<i>red red orange gold</i>
R4-7	4	1k carbon film 0.25W resistor	<i>brown black red gold</i>
C1	1	100nF miniature polyester capacitor	<i>5mm pitch</i>
D1-4	4	1N4001 diode	<i>grey band faces 'up'</i>
TR1-4	4	BC548B transistor	<i>align curved edge on pcb</i>
IC1	1	8 pin IC socket + microcontroller	<i>use socket for microcontroller</i>
BT1	1	6V AA battery box + clip	<i>red wire is 6V (V+)</i>

Additional parts required for PICAXE-08:

LINK	1	zero-ohm resistor or wire link	<i>can use offcut resistor leg</i>
CT1	1	miniature stereo PCB jack socket <i>(Rapid part 20-0137)</i>	<i>ensure 'snapped' onto pcb</i>

Optional input/output connectors:

CT	4	16A interlocking terminal block (4)	<i>5mm pitch, contacts face out</i>
----	---	-------------------------------------	-------------------------------------

Assembly Instructions

1. Solder all the resistors in position. The values of the resistors are shown on the pcb, and the colour codes are given in the table on page 1.
2. If using the PICAXE-08 system the wire link marked 'LINK' and the PICAXE stereo download socket should be soldered in position
3. Solder the diodes D1-4 in position. The grey bar should face to the right as shown in the diagram.
4. Solder the IC socket in position.
5. Solder the transistors in position, encursing the curved side of the transistor is correctly aligned.
6. Solder the rectangular polyester capacitor C1 in position. It can be used either way around.
7. (Optional) Solder the screw terminal block in position. Make sure the contacts face out. Note that the 4 way terminal block can be clipped together and/or split into smaller blocks to make the 6 way connection.
8. Solder the battery clip (or screw the battery clip into the bottom two contacts of the left hand terminal block). The red wire is connected to the V+ contact, the black wire to the 0V(G) contact. Note that the battery clip may be threaded through the holes on the board for increased connection strength.
9. Push the microcontroller chip into it's socket. Make sure pin 1 faces the capacitor.
10. Insert four AA batteries (not supplied) into the battery pack and then connect to the battery clip.

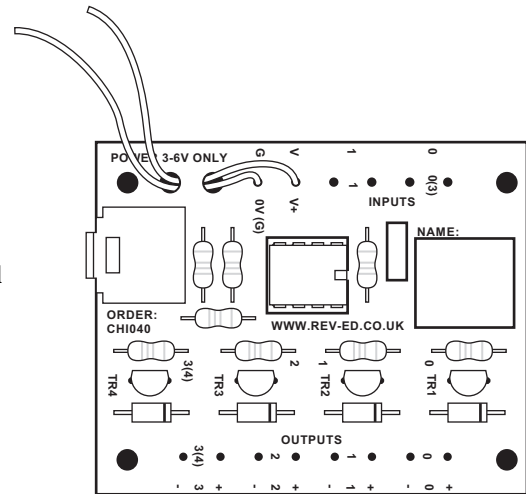

DO NOT USE A 9V PP3 BATTERY WITH THIS PRODUCT.

ONLY USE A 6V (4xAA CELL) BATTERY BOX.

Chip Factory System

When using the Chip Factory system the four outputs down the right hand side of the board are outputs 0, 1, 2, and 3. The inputs on the left hand side of the board are inputs 0 and 1. The PICAXE stereo socket and the LINK are not required.

PICAXE-08 System

When using the PICAXE-08 system the four outputs down the right hand side of the board are output pin numbers 0, 1, 2, and 4. The top input on the left hand side of the board is pin3. The input connection marked '1' is not used.

Remember that the PICAXE-08 microcontroller is a PIC12F629 pre-programmed with the PICAXE bootstrap code, so you cannot use a 'blank' PIC12F629 with the PICAXE-08 programming system. Purchase PICAXE-08 microcontrollers instead.

Connecting Inputs and Outputs

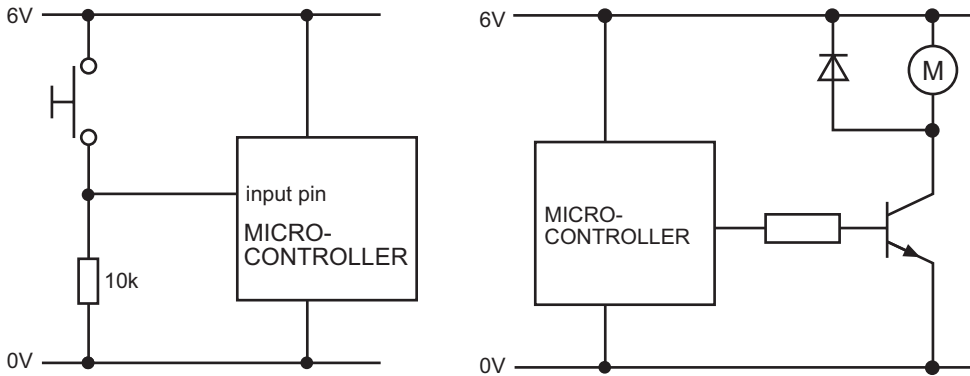

Output devices are connected between the + (red wire) and - (black wire) connections at the right hand side of the board. Input switches are connected to the left hand side of the board.

When using motors as an output device these must be suppressed with a 220nF polyester capacitor soldered across the terminals to stop electrical noise affecting the operation of the microcontroller.

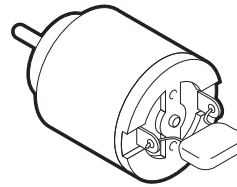

Alternate Configurations

If LEDs are to be used as the outputs the transistor buffers are not required. In this case the 1k resistors can be replaced with 330R resistors and the LED connected across the bottom two holes of the transistor socket (+ve middle hole, -ve bottom hole).

If a piezo transducer is required to generate sounds, this can be inserted in the same position as the LED (red wire to the centre transistor hole, black wire to the bottom transistor hole). Note that when using the Chip Factory system, the beep command only works on output 2.

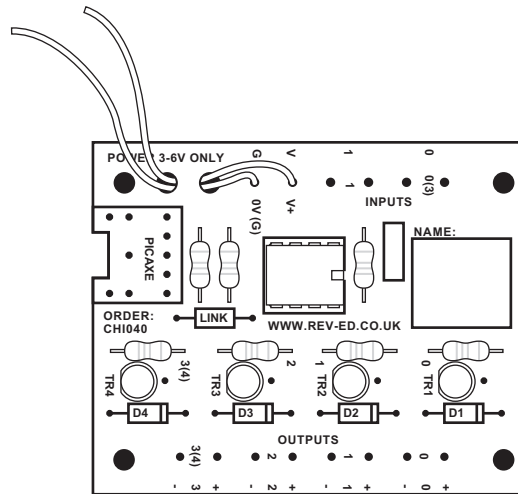

Other Notes

- The IC may be damaged if any power supply greater than 6V DC is applied to the power contacts. A 9V PP3 battery must never be used.
- Alkaline AA cells are recommended for this application.

Circuit Diagram

- The circuit diagram of the project board is shown below:

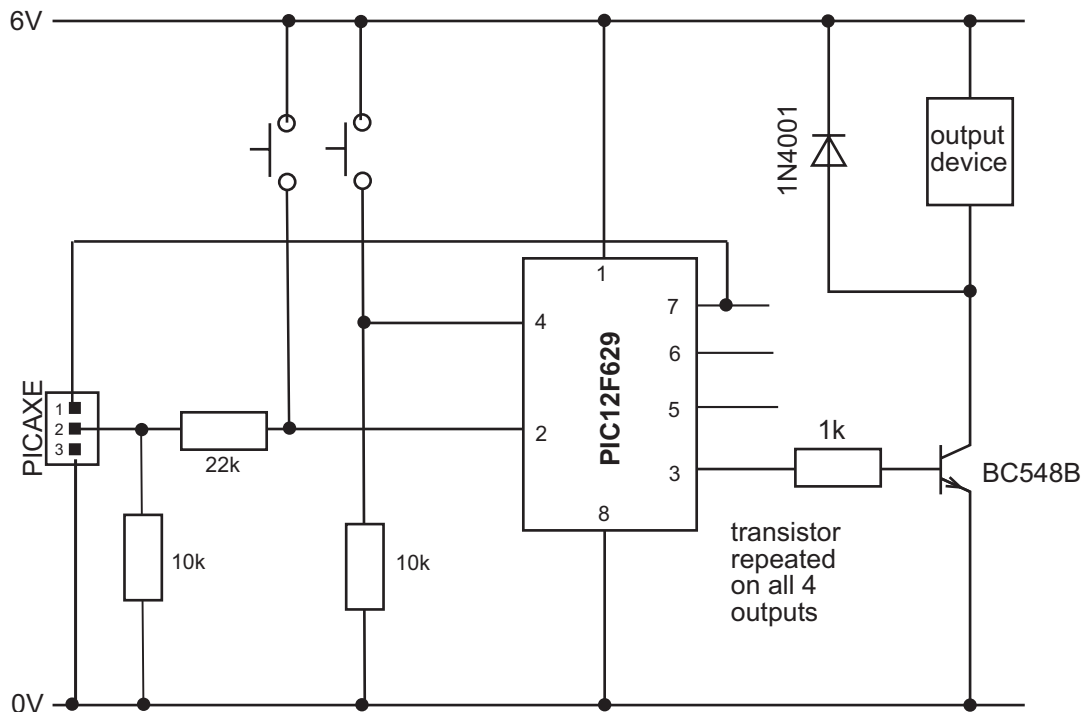

Board with optional terminal blocks fitted:

